

IBM LTO Ultrium 4 Tape Drive



# Setup, Operator, and Service Guide

*Model T1600P*



IBM LTO Ultrium 4 Tape Drive



# Setup, Operator, and Service Guide

*Model T1600P*

**Note!**

Before using this information and the product it supports, be sure to read the general information under Notices on page A-1.

To ensure that you have the latest publications, visit the web at <http://www.ibm.com/storage/lto>.

**Released August 2007**

This edition applies to the *IBM Ultrium Tape Drive Models T1600P Setup, Operator, and Service Guide*, GC27-2102-01, and to the subsequent releases and modifications until otherwise indicated in new editions.

© Copyright International Business Machines Corporation 2007. All rights reserved.

US Government Users Restricted Rights – Use, duplication or disclosure restricted by GSA ADP Schedule Contract with IBM Corp.

# Contents

Figures . . . . .	v
-------------------	---

Tables . . . . .	vii
------------------	-----

## Registering for Support Notification . . . ix

Safety and Environmental Notices . . . . .	ix
Danger Notices . . . . .	ix
Caution Notices . . . . .	ix
Laser Safety and Compliance . . . . .	x
Performing the Safety Inspection Procedure . . . . .	x
Tape Drive ac Grounding Inspection . . . . .	x
Rack Safety . . . . .	xi
Product Recycling and Disposal . . . . .	xiii
End of Life (EOL) Plan . . . . .	xiv

## Preface . . . . . xv

Related Publications . . . . .	xv
--------------------------------	----

## Chapter 1. Product Description . . . . 1-1

Drive Features . . . . .	1-1
Front Panel of the Drive . . . . .	1-2
Rear Panel of the SCSI Drive . . . . .	1-3
Rear View of the Fibre Channel Drive . . . . .	1-3
Rear View of the SAS Drive . . . . .	1-4
Cartridge Compatibility . . . . .	1-4
Speed Matching . . . . .	1-5
Channel Calibration . . . . .	1-5
Data Cartridge Capacity Scaling . . . . .	1-5
Encryption . . . . .	1-5
Supported Servers and Operating Systems . . . . .	1-6
Supported Device Drivers . . . . .	1-6
Feature Switches . . . . .	1-7
Library Interface . . . . .	1-7
SCSI Interface . . . . .	1-7
Physical Characteristics . . . . .	1-8
Speed . . . . .	1-8
Address Assignments . . . . .	1-8
Installing, Removing, or Resetting a Drive on an Active SCSI Bus . . . . .	1-8
Fibre Channel Interface . . . . .	1-8
Supported Topologies . . . . .	1-9
Physical Characteristics . . . . .	1-9
Speed . . . . .	1-10
Address Assignments . . . . .	1-10
World Wide Names . . . . .	1-10
Installing, Removing, or Resetting a Drive on an Active Fibre Channel . . . . .	1-10
SAS Interface . . . . .	1-11
Physical Characteristics . . . . .	1-11
Specifications . . . . .	1-11
Physical Specifications . . . . .	1-11
Power Specifications . . . . .	1-11
Environmental Specifications . . . . .	1-12
Other Specifications . . . . .	1-12

## Chapter 2. Installing the Drive . . . . 2-1

Avoiding Drive Damage . . . . .	2-1
Installation Overview . . . . .	2-1
Unpack the Drive . . . . .	2-1
Acclimate the Drive and Media . . . . .	2-1
Power Off the Enclosure . . . . .	2-2
Set the SCSI ID or Arbitrated Loop Physical Address . . . . .	2-2
Setting the SCSI ID (SCSI Drive Only) . . . . .	2-2
Setting the Arbitrated Loop Physical Address (Fibre Channel Drive Only) . . . . .	2-4
Set the Library Interface Protocol . . . . .	2-10
Choose Library Protocol . . . . .	2-10
Mount the Drive into an Enclosure . . . . .	2-10
Connect and Test Power to the Drive . . . . .	2-11
Connect the Internal Cable . . . . .	2-12
Connect the Library Interface RS-422 Cable (optional) . . . . .	2-12
Run Drive Diagnostics . . . . .	2-12
Install Device Drivers . . . . .	2-12
Connect the Enclosure's External SCSI, SAS, or Fibre Channel Interface to the Server . . . . .	2-13
Configure the Drive to the Server, Switch, or Hub . . . . .	2-13

## Chapter 3. Operating the Drive . . . . 3-1

Single-character Display (SCD) . . . . .	3-1
SCD Dot . . . . .	3-1
Status Light . . . . .	3-1
Unload Button . . . . .	3-3
Inserting a Tape Cartridge . . . . .	3-4
Removing a Tape Cartridge . . . . .	3-5
Mid-tape Recovery . . . . .	3-5
Cleaning the Drive Head . . . . .	3-5
Diagnostic and Maintenance Functions . . . . .	3-5
Entering Maintenance Mode . . . . .	3-7
Exiting Maintenance Mode . . . . .	3-7
Function Code 0: Maintenance Mode . . . . .	3-8
Function Code 1: Run Drive Diagnostics . . . . .	3-8
Function Code 2: Update Drive Firmware from FMR Tape . . . . .	3-9
Function Code 3: Create FMR Tape . . . . .	3-10
Function Code 4: Force a Drive Dump . . . . .	3-11
Function Code 5: Copy Drive Dump . . . . .	3-11
Function Code 6: Run Host Interface Wrap Test . . . . .	3-12
Function Code 7: Run RS-422 Wrap Test . . . . .	3-14
Function Code 8: Unmake FMR Tape . . . . .	3-14
Function Code 9: Display Error Code Log . . . . .	3-15
Function Code A: Clear Error Code Log . . . . .	3-15
Function Code C: Insert Cartridge into Tape Drive . . . . .	3-16
Function Code E: Test Cartridge & Media . . . . .	3-16
Function Code F: Write Performance Test . . . . .	3-17
Function Code H: Test Head . . . . .	3-18
Function Code J: Fast Read/Write Test . . . . .	3-19
Function Code L: Load/Unload Test . . . . .	3-20

Function Code P: Post Error Reporting Enabled	3-20
Function Code U: Post Error Reporting Disabled	3-21
Updating Firmware	3-21
Updating Firmware through the Host Interface	3-22
Updating Firmware through the Library/Drive Interface	3-22
ITDT Firmware Update, Dump Retrieval and Library/Drive Test Tool	3-22
Updating the Firmware with an FMR Tape Cartridge	3-23

## **Chapter 4. Using Ultrium Media . . . . 4-1**

Data Cartridges	4-1
Cartridge Compatibility	4-2
Capacity Scaling	4-3
WORM (Write Once, Read Many)	4-3
WORM Media	4-3
Data Security on WORM Media	4-3
WORM Media Errors	4-3
Requirements for WORM Capability	4-4
Cleaning Cartridge	4-4
Cartridge Memory Chip (LTO-CM)	4-4
Bar Code Label	4-4
Guidelines for Using Bar Code Labels	4-5
Write-Protect Switch	4-6
Handling the Cartridges	4-7
Provide Training	4-7
Ensure Proper Packaging	4-7
Provide Proper Acclimation and Environmental Conditions	4-8
Perform a Thorough Inspection	4-8
Handle the Cartridge Carefully	4-9
Examples of Cartridge Problems	4-9
Repositioning or Reattaching a Leader Pin	4-10
Repositioning a Leader Pin	4-10
Reattaching a Leader Pin	4-12
Environmental and Shipping Specifications for Tape Cartridges	4-16
Disposing of Tape Cartridges	4-17
Ordering Media Supplies	4-18
Ordering Bar Code Labels	4-19

## **Chapter 5. Resolving Problems . . . . 5-1**

Methods of Receiving Errors and Messages	5-2
Error Codes and Messages	5-2
Using Sense Data	5-9
Obtaining Error Information from the AS/400 or iSeries with RISC Processor	5-10
Obtaining Error Information from the RS/6000 or pSeries	5-10
Obtaining a Drive Dump	5-13
Using ITDT	5-13
Using the Drive	5-13
Using a Device Driver Utility	5-14
Viewing the Drive Error Log	5-14
Resolving Problems Reported by the Server	5-14
Fixing SCSI Bus Errors	5-15
Fixing Fibre Channel Errors	5-16
Resolving Media-Related Problems	5-19

## **Chapter 6. Parts List . . . . . 6-1**

### **Information for Authorized Service**

#### **Personnel . . . . . A-1**

Removing a Drive from an Enclosure	A-1
Removing a SCSI Drive from an Enclosure	A-1
Removing a Fibre Channel Tape Drive from an Enclosure	A-1
Removing a SAS Drive from an Enclosure	A-2
Manually Removing a Tape Cartridge	A-3
Before You Begin	A-3
Recommended Tools	A-4
Beginning Procedure	A-4
Tape Spooled Off Supply Reel	A-5
Tape Pulled from or Broken near Leader Pin	A-6
Tape Broken in Mid-tape	A-8
Tape Tangled along Tape Path	A-9
No Apparent Failure or Damage to Tape	A-11

#### **Notices . . . . . B-1**

#### **Glossary . . . . . C-1**

#### **Index . . . . . X-1**

## Figures

1.	AC Grounding Diagram (50 Hz and 60 Hz)	xi
1-1.	View of the drive with and without the bezel . . . . .	1-1
1-2.	Front panel of the drive . . . . .	1-2
1-3.	Rear panel of the SCSI drive, Ultra 160 and Ultra 320 . . . . .	1-3
1-4.	Rear view of the Fibre Channel drive	1-3
1-5.	Rear view of the SAS drive . . . . .	1-4
2-1.	Temperature of the drive is taken near the air intake area. . . . .	2-2
2-2.	SCSI ID settings on the SCSI ID connector	2-3
2-3.	Setting the Loop ID and the AL_PA	2-5
2-4.	Location of the Fibre Channel (FC) configuration/status connector. . . . .	2-10
2-5.	Mounting holes on drive . . . . .	2-11
3-1.	Inserting a cartridge into the drive	3-4
4-1.	The IBM LTO Ultrium 800 GB Data Cartridge . . . . .	4-1
4-2.	Ultrium WORM Tape Cartridge . . . . .	4-3
4-3.	Sample bar code label on the LTO Ultrium 4 Tape Cartridge . . . . .	4-5
4-4.	Setting the write-protect switch . . . . .	4-6
4-5.	Tape cartridges in a Turtlecase . . . . .	4-7
4-6.	Double-boxing tape cartridges for shipping	4-8
4-7.	Checking for gaps in the seams of a cartridge . . . . .	4-9
4-8.	Leader pin in the incorrect and correct positions . . . . .	4-11
4-9.	Placing the dislodged leader pin into the correct position . . . . .	4-11
4-10.	Rewinding the tape into the cartridge	4-12
4-11.	Leader Pin Reattachment Kit . . . . .	4-13
4-12.	Attaching the leader pin attach tool to the cartridge . . . . .	4-14
4-13.	Winding the tape out of the cartridge	4-15
4-14.	Removing the C-clip from the leader pin	4-15
4-15.	Attaching the leader pin to the tape	4-16
5-1.	Example of an error log from the AS/400 or IBM eServer iSeries. . . . .	5-10
5-2.	Example of sense data from the AS/400 or IBM eServer iSeries . . . . .	5-10
5-3.	Example of an AIX ERRPT Drive Error Log	5-12
5-4.	Example of an error that suggests a SCSI bus problem . . . . .	5-13
A-1.	Removing the cover from the internal drive	A-4
A-2.	Using hex wrench to rewind tape into cartridge . . . . .	A-5
A-3.	Drive with cover removed to reveal gear train. . . . .	A-6
A-4.	Leader Block Assembly (LBA) . . . . .	A-7
A-5.	Using hex wrench to rewind tape into cartridge . . . . .	A-8
A-6.	Using hex wrench to rewind tape into cartridge . . . . .	A-9
A-7.	Drive with cover removed to reveal gear train. . . . .	A-10
A-8.	Leader Block Assembly (LBA) . . . . .	A-11
A-9.	Using hex wrench to rewind tape into cartridge . . . . .	A-12
A-10.	Drive with cover removed to reveal gear train. . . . .	A-13
A-11.	Leader Block Assembly (LBA)	A-14





---

## Tables

1-1.	Feature Switch Definitions. . . . .	1-7	4-2.	Environment for operating, storing, and shipping the LTO Ultrium Tape Cartridge . . . . .	4-17
1-2.	Choosing the port for your topology and Fibre Channel connection . . . . .	1-9	4-3.	Media supplies . . . . .	4-18
2-1.	ID Settings that provide status about the loop . . . . .	2-5	4-4.	Authorized suppliers of custom bar code labels . . . . .	4-20
2-2.	ID settings that provide additional Loop IDs	2-7	5-1.	Troubleshooting tips. . . . .	5-1
2-3.	Topology and speed settings for the drive	2-9	5-2.	Methods of receiving errors and messages	5-2
3-1.	Meaning of Status Light and Single-character Display (SCD) . . . . .	3-2	5-3.	Error codes on the Single-character Display	5-3
3-2.	Functions that the Unload Button performs	3-3	6-1.	Tools and supplies for the IBM LTO Ultrium 4 Tape Drive . . . . .	6-1
3-3.	Diagnostic and maintenance functions	3-6			
4-1.	Ultrium data cartridge compatibility with Ultrium tape drive . . . . .	4-2			



---

## Registering for Support Notification

Support Notification registration provides email notification when new firmware levels have been updated and are available for download and installation. To register for Support Notification, visit the web at <http://www-304.ibm.com/jct01004c/systems/support/storage/news/05072007SupportNotif.html>.

---

## Safety and Environmental Notices

When using this product, observe the danger and caution notices contained in this guide. The notices are accompanied by symbols that represent the severity of the safety condition.

Danger notices contain a Dxxxx reference number. Caution notices contain a Cxxxx reference number. Rack safety notices contain a Rxxxx reference number. Use the reference number to locate the translation in *IBM Translated Safety Notices*, 96P0851.

The sections that follow define each type of safety notice.



### Danger Notices

A danger notice calls attention to a situation that is potentially lethal or extremely hazardous to people.

If the symbol is...	It means...
	A danger notice calls attention to a situation that is potentially lethal or extremely hazardous to people. A lightning bolt symbol always accompanies a danger notice to represent a dangerous electrical condition.

### Caution Notices

A caution notice calls attention to a situation that is potentially hazardous to people because of some existing condition. A caution notice can be accompanied by one of several symbols:

If the symbol is...	It means...
	A hazardous electrical condition with less severity than electrical danger.
	A generally hazardous condition not represented by other safety symbols.
 Class I	A hazardous condition due to the use of a laser in the product. Laser symbols are always accompanied by the classification of the laser as defined by the U. S. Department of Health and Human Services (for example, Class I, Class II, and so forth).

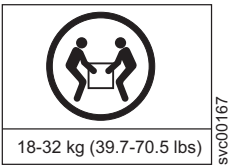
If the symbol is...	It means...
	A hazardous condition due to mechanical movement in or around the product.
	A hazardous condition due to the weight of the unit. Weight symbols are accompanied by an approximation of the product's weight.

## Laser Safety and Compliance

Before using the library, review the following laser safety information.

### Class I Laser Product

The library may contain a laser assembly that complies with the performance standards set by the U.S. Food and Drug Administration for a Class I laser product. Class I laser products do not emit hazardous laser radiation. The library has the necessary protective housing and scanning safeguards to ensure that laser radiation is inaccessible during operation or is within Class I limits. External safety agencies have reviewed the library and have obtained approvals to the latest standards as they apply.

## Performing the Safety Inspection Procedure

Before you service the unit, perform the following safety inspection procedure:

1. Stop all activity on the host bus.
2. Turn off the power to the tape drive.
3. Disconnect the host interface cable.
4. Check the SCSI bus terminator for damage (SCSI drive only).
5. Unplug the tape drive's power cord from the electrical outlet.
6. Check the tape drive's power cord for damage, such as a pinched, cut, or frayed cord.
7. Check the tape drive's host interface cable for damage.
8. Check the cover of the tape drive for sharp edges, damage, or alterations that expose its internal parts.
9. Check the cover of the tape drive for proper fit. It should be in place and secure.
10. Check the product label on the bottom of the tape drive to make sure that it matches the voltage at your outlet.

## Tape Drive ac Grounding Inspection

1. Power off the drive.
2. Disconnect all cables.
3. See Figure 1 on page xi which is provided for reference only. Disconnect the power cord from its source.
4. Inspect the power cable for visible cracks, wear, or damage.

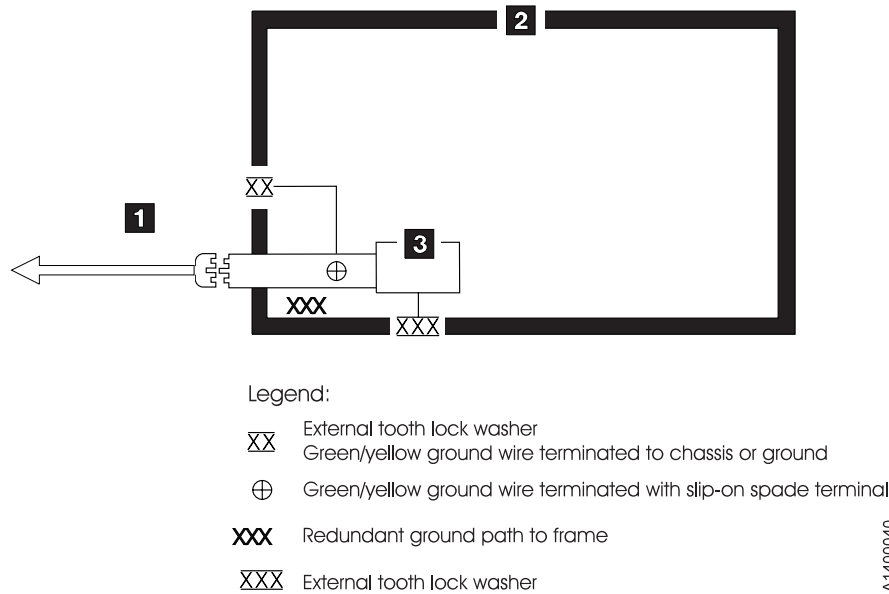

Figure 1. AC Grounding Diagram (50 Hz and 60 Hz)

## Rack Safety

### DANGER

The following general safety information should be used for all rack mounted devices.

- Always lower the leveling pads on the rack cabinet.
- Always install stabilizer brackets on the rack cabinet.
- To avoid hazardous conditions due to uneven mechanical loading, always install the heaviest devices in the bottom of the rack cabinet. Always install servers and optional devices starting from the bottom of the rack cabinet.
- Rack mounted devices are not to be used as a shelf or work space. Do not place any object on top of rack mounted devices.
- Each rack cabinet might have more than one power cord. Be sure to disconnect all power cords in the rack cabinet before servicing any device in the rack cabinet.
- Connect all devices installed in a rack cabinet to power devices installed in the same rack cabinet. Do not plug a power cord from a device installed in one rack cabinet into a power device installed in a different rack cabinet.
- An electrical outlet that is not correctly wired could place hazardous voltage on the metal parts of the system or the devices that attach to the system. It is the responsibility of the customer to ensure that the outlet is correctly wired and grounded to prevent an electrical shock.

### CAUTION:

Removing components from the upper positions in the rack cabinet improves rack stability during relocation. Follow these general guidelines whenever you relocate a populated rack cabinet within a room or building:

- Do not install a unit in a rack where the internal rack ambient temperatures will exceed the manufacturer's recommended ambient temperature for all your rack mounted devices.
- Do not install a unit in a rack where the air flow is compromised. Ensure that air flow is not blocked or reduced on any side of the unit.
- Connect the equipment to the supply circuit such that overloading of the circuits does not compromise the supply wiring or overcurrent protection. To provide the correct power connection to a rack, refer to the rating labels located on the equipment in the rack to determine the total power requirement of the supply circuit.
- (For sliding drawers) Do not pull out or install any drawer or feature if the rack stabilizer brackets are not attached to the rack. Do not pull out more than one drawer at a time. The rack may become unstable if you pull out more than one drawer at a time.
- (For fixed drawers) Do not move a fixed drawer. Attempting to move the drawer partially or completely out of the rack may cause the rack to become unstable or cause the drawer to fall out of the rack.

(R001)

- Reduce the weight of the rack cabinet by removing equipment starting at the top of the rack cabinet. When possible, restore the rack cabinet to the configuration of the rack cabinet as you received it. If this configuration is not known, you must do the following:
  - Remove all devices in the 32U position and above.
  - Ensure that the heaviest devices are installed in the bottom of the rack cabinet.
  - Ensure that there are no empty U-levels between devices installed in the rack cabinet below the 32U level.
- If the rack cabinet you are relocating is part of a suite of rack cabinets, detach the rack cabinet from the suite.
- Inspect the route that you plan to take to eliminate potential hazards.
- Verify that the route that you choose can support the weight of the loaded rack cabinet. Refer to the documentation that comes with your rack cabinet for the weight of a loaded rack cabinet.
- Verify that all door openings are at least 760 x 230 mm (30 x 80 in.).
- Ensure that all devices, shelves, drawers, doors, and cables are secure.
- Ensure that the four leveling pads are raised to their highest position.
- Ensure that there is no stabilizer bracket installed on the rack cabinet during movement.
- Do not use a ramp inclined at more than ten degrees.
- Once the rack cabinet is in the new location, do the following:
  - Lower the four leveling pads.
  - Install stabilizer brackets on the rack cabinet.
  - If you removed any devices from the rack cabinet, repopulate the rack cabinet from the lowest position to the highest position.
- If a long distance relocation is required, restore the rack cabinet to the configuration of the rack cabinet as you received it. Pack the rack cabinet in the original packaging material, or equivalent. Also lower the leveling pads to raise the casters off of the pallet and bolt the rack cabinet to the pallet.

(R002)

## Product Recycling and Disposal

This unit must be recycled or discarded according to applicable local and national regulations. IBM encourages owners of information technology (IT) equipment to responsibly recycle their equipment when it is no longer needed. IBM offers a variety of product return programs and services in several countries to assist equipment owners in recycling their IT products. Information on IBM product recycling offerings can be found on IBM's Internet site at <http://www.ibm.com/ibm/environment/products/prp.shtml>.

Esta unidad debe reciclarse o desecharse de acuerdo con lo establecido en la normativa nacional o local aplicable. IBM recomienda a los propietarios de equipos de tecnología de la información (TI) que reciclen responsablemente sus equipos cuando éstos ya no les sean útiles. IBM dispone de una serie de programas y servicios de devolución de productos en varios países, a fin de ayudar a los propietarios de equipos a reciclar sus productos de TI. Se puede encontrar información sobre las ofertas de reciclado de productos de IBM en el sitio web de IBM <http://www.ibm.com/ibm/environment/products/prp.shtml>.

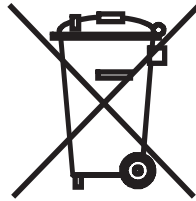

**Notice:** This mark applies only to countries within the European Union (EU) and Norway.

Appliances are labeled in accordance with European Directive 2002/96/EC concerning waste electrical and electronic equipment (WEEE). The Directive determines the framework for the return and recycling of used appliances as applicable throughout the European Union. This label is applied to various products to indicate that the product is not to be thrown away, but rather reclaimed upon end of life per this Directive.

In accordance with the European WEEE Directive, electrical and electronic equipment (EEE) is to be collected separately and to be reused, recycled, or recovered at end of life. Users of EEE with the WEEE marking per Annex IV of the WEEE Directive, as shown above, must not dispose of end of life EEE as unsorted municipal waste, but use the collection framework available to customers for the return, recycling and recovery of WEEE. Customer participation is important to minimize any potential effects of EEE on the environment and human health due to the potential presence of hazardous substances in EEE. For proper collection and treatment, contact your local IBM representative.

### Battery Return Program

This product may contain sealed lead acid, nickel cadmium, nickel metal hydride, lithium, or lithium ion battery. Consult your user manual or service manual for specific battery information. The battery must be recycled or disposed of properly. Recycling facilities may not be available in your area. For information on disposal of batteries outside the United States, go to <http://www.ibm.com/ibm/environment/products/batteryrecycle.shtml> or contact your local waste disposal facility.

In the United States, IBM has established a return process for reuse, recycling, or proper disposal of used IBM sealed lead acid, nickel cadmium, nickel metal hydride, and other battery packs from IBM Equipment. For information on proper disposal of these batteries, contact IBM at 1-800-426-4333. Please have the IBM part number listed on the battery available prior to your call.

For Taiwan:



Please recycle batteries.

廢電池請回收

For the European Union:

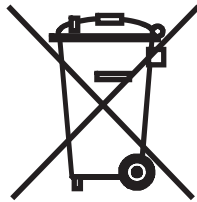

For California:

Perchlorate Material - special handling may apply. See [www.dtsc.ca.gov/hazardouswaste/perchlorate](http://www.dtsc.ca.gov/hazardouswaste/perchlorate).

The foregoing notice is provided in accordance with California Code of Regulations Title 22, Division 4.5 Chapter 33. Best Management Practices for Perchlorate Materials. This product/part may include a lithium manganese dioxide battery which contains a perchlorate substance.

## End of Life (EOL) Plan

This box is a purchased unit. Therefore, it is the sole responsibility of the purchaser to dispose of it in accordance with local laws and regulations at the time of disposal. This unit contains recyclable materials. The materials should be recycled where facilities are available and according to local regulations. In some areas IBM may provide a product take-back program that ensures proper handling of the product. Contact your IBM® representative for more information.



---

## Preface

This guide describes how to install and use the IBM T1600P Tape Drive in the following chapters:

Chapter 1, “Product Description,” on page 1-1 describes the product features, discusses supported servers, operating systems, and device drivers, and lists hardware specifications.

Chapter 2, “Installing the Drive,” on page 2-1 gives unpacking, set up, and configuration information.

Chapter 3, “Operating the Drive,” on page 3-1 describes the Unload Button, and Status Light and explains the function of the Single-character Display. It gives instruction on inserting and removing a tape cartridge, describes methods of updating drive firmware, and explains how to clean the tape drive. It also lists diagnostic and maintenance functions.

Chapter 4, “Using Ultrium Media,” on page 4-1 describes the types of tape cartridges to use and defines the conditions for storing and shipping them. It also describes how to handle the cartridges, how to set a cartridge’s write-protect switch, and how to order additional cartridges.

Chapter 5, “Resolving Problems,” on page 5-1 describes error codes and messages, obtaining drive dumps, viewing error logs, and resolving problems.

“Removing a Drive from an Enclosure” on page A-1 describes removing the drive and manually removing a tape cartridge.

Chapter 6, “Parts List,” on page 6-1 lists the miscellaneous parts used with the drive such as wrap plugs and terminators.

---

## Related Publications

- *IBM System Storage® Ultrium Tape Drive Quick Reference*, GC26-7710, illustrates how to configure and operate the IBM LTO Ultrium 4 Tape Drive.
- *IBM System Storage LTO Ultrium Tape Drive SCSI Reference*, GA32-0450, gives information about the supported SCSI commands and protocol that govern the behavior of the SCSI interface for the IBM LTO Ultrium 4 Tape Drive . The SCSI reference also includes information about the TapeAlert flags that are supported.
- *IBM Ultrium Device Drivers Installation and User’s Guide*, GC27-2130, provides instructions for attaching IBM-supported hardware to open-systems operating systems. It indicates what devices and levels of operating systems are supported, gives the requirements for adapter cards, and tells how to configure servers to use the device driver with the Ultrium family of devices. You can obtain this reference via File Transfer Protocol (FTP) at <ftp://ftp.software.ibm.com/storage/devdrv>.
- *IBM Ultrium Device Drivers Programming Reference*, GA32-0566, supplies information to application developers who want to integrate their open-systems applications with IBM-supported Ultrium hardware. The reference contains information about the application programming interfaces (APIs) for each of the

various supported operating-system environments. You can obtain this reference via File Transfer Protocol (FTP) at <ftp://ftp.software.ibm.com/storage/devdrv>.

- *IBM Translated Safety Notices*, 96P0851, provides translation of danger and caution notices.
- *IBM Tape Device Drivers: Encryption Support*, GA32-0565-00, provides information for implementing tape encryption.

---

## Chapter 1. Product Description

The IBM LTO Ultrium 4 Tape Drive is a high-performance, high-capacity data-storage device that is designed to backup and restore open systems applications. The drive can be integrated into an enclosure, such as a desktop unit, tape autoloader, or tape library. It is the fourth generation in the Ultrium series of products, and is available with a Small Computer Systems Interface (SCSI), Fibre Channel interface (FC) or Serial Attached SCSI interface (SAS).

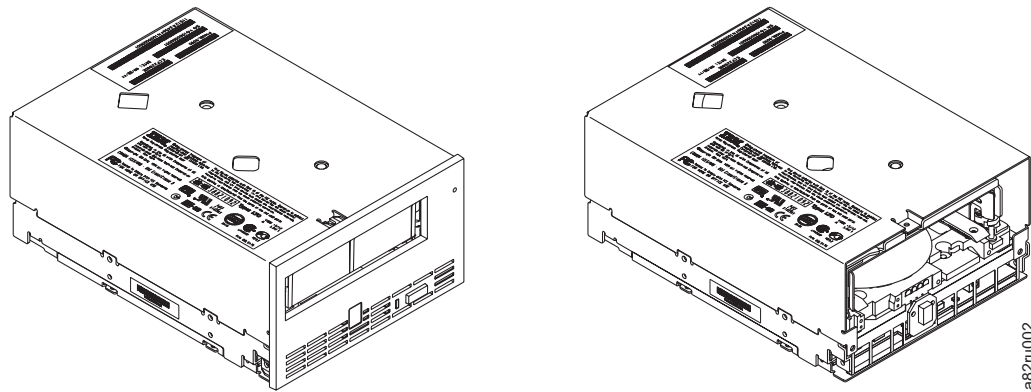

Figure 1-1. View of the drive with and without the bezel

---

### Drive Features

The drive offers the following features:

- One of the following host interfaces:
  - 320 MB/sec Ultra320 Low Voltage Differential (LVD) Small Computer Systems Interface (SCSI)
  - 160 MB/sec Ultra160 Low Voltage Differential (LVD) Small Computer Systems Interface (SCSI)
  - 4 Gb FC-4 Fibre Channel interface
  - 3 Gbps Serial Attached Small Computer Systems Interface (SAS)
- Support for RS-422 connection to a library interface. Supports the following two protocols:
  - LDI - IBM proprietary Library Drive Interface protocol.
  - ADI - InterNational Committee for Information Technology Standards (INCITS) T10 SCSI Storage Devices' Automation Drive Interface protocol.
- Support for WORM (Write Once Read Many) on WORM cartridge types
- Native storage capacity of 800 GB per cartridge (1600 GB at 2:1 compression) when using Ultrium 4 cartridges.
- Native data transfer rate of up to 120 MB per second with Ultrium 4 media
- Burst data transfer rate of 160 MB per second for the U160 SCSI interface, 320 MB per second for the U320 SCSI interface, 300 MB per second for the SAS interface, , and 400 MB per second for the Fibre Channel interface.
- 256 MB read-and-write cache.

- Support for encryption of data on Ultrium 4 cartridges (Fibre Channel and SAS and U320 SCSI drive only).
- New SCSI Log Pages
  - Device Statistics
  - Tape Diagnostic Data
  - Performance Characteristics

This tape drive is a drive brick that can be integrated into an enclosure, server, or library. The enclosure can be designed for standalone or rack units.

## Front Panel of the Drive

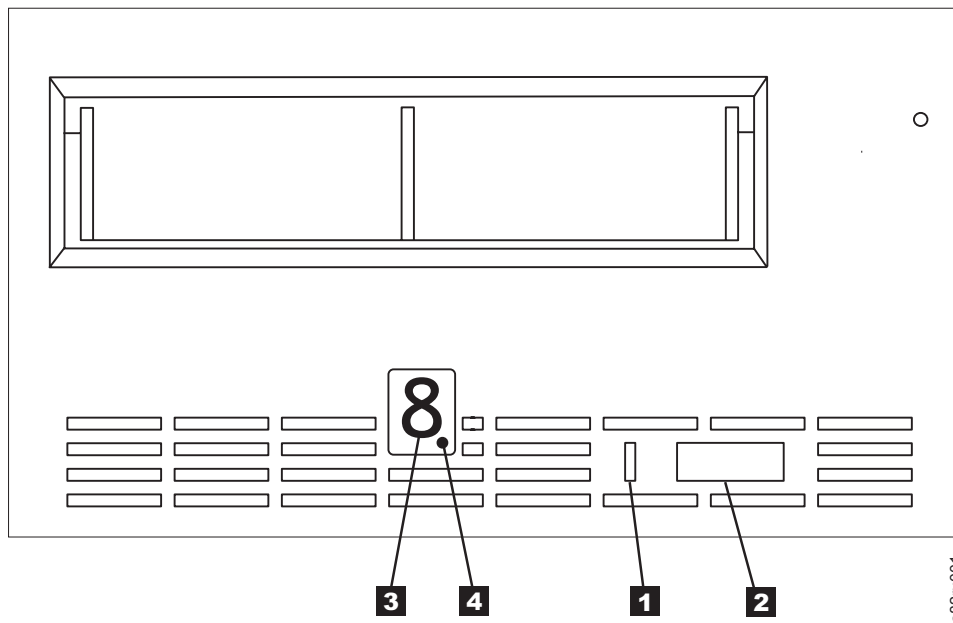

Figure 1-2. Front panel of the drive

- |          |               |          |                                |
|----------|---------------|----------|--------------------------------|
| <b>1</b> | Status Light  | <b>3</b> | Single-character Display (SCD) |
| <b>2</b> | Unload Button | <b>4</b> | SCD Dot                        |

## Rear Panel of the SCSI Drive

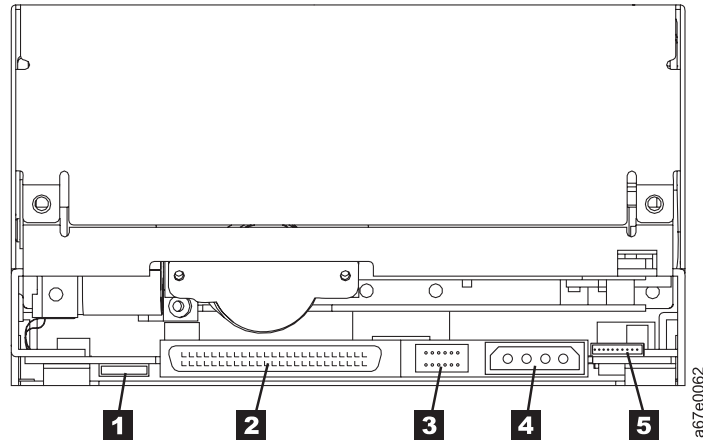

Figure 1-3. Rear panel of the SCSI drive, Ultra 160 and Ultra 320

- |          |                   |          |  |
|----------|-------------------|----------|--|
| <b>1</b> | Feature Switch    | <b>4</b> | Power Connector  |
| <b>2</b> | SCSI connector    | <b>5</b> | RS-422 connector for library interfaces (LDI or ADI) selectable via Feature Switch 5 |
| <b>3</b> | SCSI ID connector |          |  |

## Rear View of the Fibre Channel Drive

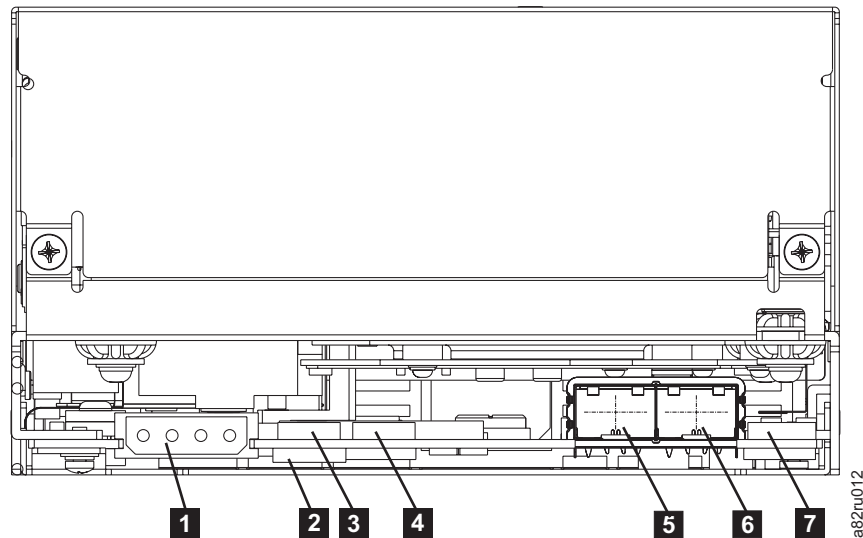

Figure 1-4. Rear view of the Fibre Channel drive

- |          |                  |                |                                |
|----------|------------------|----------------|--------------------------------|
| <b>1</b> | Power connector  | <b>4</b>       | Speed/topology connector (J14) |
| <b>2</b> | Feature switches | <b>5&amp;6</b> | Fibre Channel connectors:      |
|          |                  |                | 5) Port 0                      |
|          |                  |                | 6) Port 1, for future use      |

- |          |                                   |          |  |
|----------|-----------------------------------|----------|--|
| <b>3</b> | AL_PA/LID/ status connector (J13) | <b>7</b> | RS-422 connector for library interfaces (LDI or ADI) selectable via Feature Switch 5 |
|----------|-----------------------------------|----------|--|

---

## Rear View of the SAS Drive

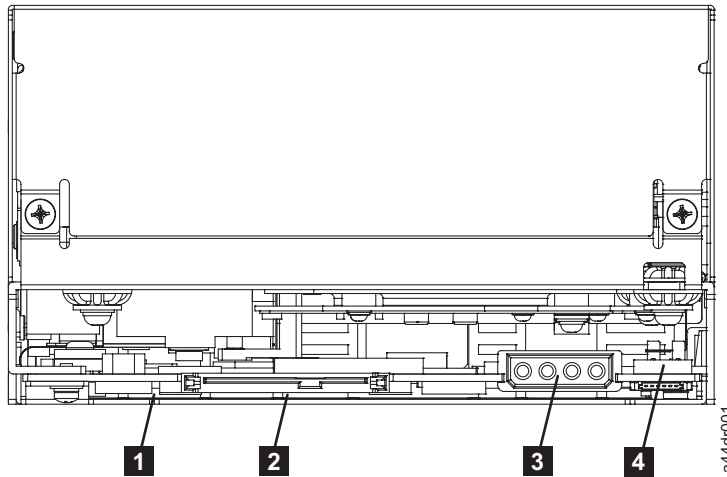

Figure 1-5. Rear view of the SAS drive

- |          |                  |          |  |
|----------|------------------|----------|--|
| <b>1</b> | Feature switches | <b>2</b> | SAS connectors   |
| <b>3</b> | Power connector  | <b>4</b> | RS-422 connector for library interfaces (LDI or ADI) selectable via Feature Switch 5 |

---

## Cartridge Compatibility

The Ultrium 4 drive uses the IBM LTO Ultrium 800 GB Data Cartridge and is compatible with the cartridges of its predecessors, the IBM Ultrium Tape Drive Generation 2 and Generation 3. The drive performs the following functions:

- Reads and writes Ultrium 4 cartridges to Ultrium 4 format, including WORM and Data Encryption
- Reads and writes Ultrium 3 cartridges to Ultrium 3 format, including WORM
- Reads but does not write Ultrium 2 cartridges
- Does not read or write Ultrium 1 cartridges

The drive reads tapes that have been written by other licensed Ultrium 2, 3, and 4 drives, and writes to tapes that can be read by other licensed Ultrium 3 and 4 drives.

In addition to using the IBM LTO Ultrium Data Cartridge with up to 800 GB capacity, the drive also offers read/write capability for certified LTO Ultrium tape cartridges.

---

## Speed Matching

To improve system performance, the drive uses a technique called *speed matching* to dynamically adjust its native (uncompressed) data rate to the slower data rate of a server. With speed matching, the drive operates at one of six speeds when reading or writing the Ultrium 3 or Ultrium 4 cartridge format. Native data rates are as follows:

- Ultrium 4 (Read/Write): 30, 48, 66, 84, 103, or 120 MB per second (MB/s)
- Ultrium 3 (Read/Write): 30, 40, 50, 60, 70, or 80 MB per second (MB/s)
- Ultrium 2 (Read only): 15, 19, 22, 26, or 30 MB per second (MB/s)

If the server's net (compressed) data rate is between two of the preceding native data rates, the drive calculates the appropriate data rate at which to operate. Speed matching dramatically reduces backhitch, the condition that occurs when a tape stops, reverses, and restarts motion. A backhitch is usually the result of a mismatch between the data rates of the server and the drive.

---

## Channel Calibration

System performance is further optimized by a feature called *channel calibration*, in which the drive automatically customizes each read/write data channel to compensate for variations in such things as the recording channel's transfer function, the media, and characteristics of the drive head.

---

## Data Cartridge Capacity Scaling

The SET CAPACITY SCSI command enables a customer to capacity scale a data cartridge to enable faster random access. As an example, a customer could capacity scale a data cartridge to 20% of its normal length which improves the average access time by almost a factor of 5; however, it also reduces the native capacity of the tape accordingly (for example, capacity of 800 Gb will be reduced to 160 Gb).

---

## Encryption

IBM LTO Ultrium 4 Tape Drive supports host Application Managed Encryption (AME), using T10 encryption methods, for Ultra320 SCSI, SAS and Fibre Channel drives only. Encryption is not supported on the Ultra160 SCSI drive. Data encryption is supported with LTO Ultrium 4 Data Cartridges only.

The encryption enabled drive contains the necessary hardware and firmware to encrypt and decrypt host tape application data. Encryption policy and encryption keys are provided by the host application and there is no encryption setup required (or available) for this drive. A drive digital certificate is installed at manufacturing time. Each drive receives a unique serial number and certificate. The T10 Application may validate each drive instance by checking the drive's digital certificate.

Application-managed encryption is supported on AIX®, Windows Server 2003, Linux®, and Solaris. Encryption requires the latest device drivers available on the ftp download site: <ftp://ftp.software.ibm.com/storage/devdrv/>.

For more details, see the IBM Tape Device Drivers Encryption Support documentation, and the IBM LTO Ultrium Tape Drive SCSI Reference documentation.

---

## Supported Servers and Operating Systems

To determine the latest supported attachments, visit the web at <http://www.ibm.com/storage/lto> and look for the System Storage interoperability information. For specific instructions about attaching the drive, see Chapter 2, “Installing the Drive,” on page 2-1.

---

## Supported Device Drivers

Device drivers enable the drive to interact with a variety of servers. To properly install an IBM device driver (if required), refer to the *IBM Ultrium Device Drivers Installation and User's Guide*. For applications that use other device drivers, see the application's documentation to determine which drivers to use.

IBM maintains the latest levels of device drivers and driver documentation for the drive on the Internet. You can access this material by performing one of the following procedures. (**Note: If you do not have Internet access and you need information about device drivers, contact your Marketing Representative.**)

- Using a browser, type one of the following:
  - <http://www.ibm.com/storage>
  - <ftp://ftp.software.ibm.com/storage/devdrv>
  - <ftp://207.25.253.26/storage/devdrv>
- Using an IBM FTP site, enter the following specifications:
  - FTP site: `ftp.software.ibm.com`
  - IP Addr: `207.25.253.26`
  - Userid: `anonymous`
  - Password: (use your current e-mail address)
  - Directory: `/storage/devdrv`

IBM provides PostScript- and PDF-formatted versions of its documentation in the `/storage/devdrv/doc` directory:

- `IBM_ultrium_tape_IUG.ps` and `IBM_ultrium_tape_IUG.pdf` contain the current version of the *IBM Ultrium Device Drivers Installation and User's Guide*
- `IBM_ultrium_tape_PROGREF.ps` and `IBM_ultrium_tape_PROGREF.pdf` contain the current version of the *IBM Ultrium Device Drivers Programming Reference*

Device drivers and utilities for each supported server are beneath `/storage/devdrv/` in the following directories (the device driver for the iSeries™ or AS/400® server is included in the OS/400® operating system):

- AIX®
- HPUX
- Linux™
- Solaris
- Tru64
- Win2003



---

## Feature Switches

The Ultrium 4 Tape Drive contains eight factory-set feature switches by which the drive is configured for unique function. The feature switches are preset at the factory but are described here in case the feature switch settings need to be inspected for your application.

The feature switch is located on the rear panel of the tape drive. Refer to Figure 1-3 on page 1-3, Figure 1-4 on page 1-3, and Figure 1-5 on page 1-4 for the location of the switch. The switch positions are labeled 1 through 8 (see Table 1-1). The on and off positions are marked on the switch. The default settings for the feature switches are all switches placed in the "OFF" position.

*Table 1-1. Feature Switch Definitions*

Switch Position	"On" Function	"Off" Function
1	Library interface at 9600 baud / polled	Library interface at 38,400 baud / non-polled
2	Library interface uses two stop bits	Library interface uses one stop bit
3	Fibre Channel AL_PA/LID/status connector uses 7 pins for AL_PA	Fibre Channel AL_PA/LID/status connector uses 6 pins for AL_PA and 2 pins for status
4	Library interface at 115,000 baud rate	Switch #1 active
5	Enable ADI Interface protocol	Enable LDI Interface protocol
6	Reserved	Reserved
7	Disable head brush ERP	Allows head brush ERP
8	Reserved	Reserved

The head brush error recovery procedure (ERP) will cause the cartridge to temporarily extend beyond the front of the bezel. This is not acceptable in some automation environments. For these automation environments the head brush error recovery procedure (ERP) is disabled.

---

## Library Interface

Using the RS-422 Connector for library interfaces, the drive supports the Library Drive Interface (LDI) protocol or the Automation Drive Interface (ADI) protocol.

LDI is an IBM proprietary Library Drive Interface protocol.

ADI is an Automation Drive Interface protocol that supports the International Committee for Information Technology Standards (INCITS) T10 SCSI Storage Device Automation Drive Interface protocol.

---

## SCSI Interface

To communicate with a server, the SCSI drive uses the Ultra160 LVD SCSI interface.

## Physical Characteristics

The drive includes connectors for the SCSI signal (HD68), the SCSI ID, and drive power. The HD68 connector is a high-density, 68-pin, D-shell receptacle for attachment to the SCSI host. The drive supports LVD SCSI cables with HD68 connectors.

## Speed

The Ultra160 LVD SCSI interface is compatible with older SCSI technology and is capable of data transmission at 160 MB/s. Ultra160 SCSI uses the three management features of the Ultra3 SCSI standard that specifically affect data transfer rate:

- **Double transition clocking** - a data-transfer technique that enables data rates to double without increasing clock speed
- **Domain validation** - a procedure that detects and adjusts SCSI configuration issues that might prevent interoperation between SCSI devices
- **Cyclic redundancy check (CRC)** - an error-checking technique

Because the cables, connectors, and terminators are the same for the Ultra160 and Ultra2 SCSI interfaces, devices with those interfaces can be mixed on the same bus and each device can operate at its fully rated speed.

## Address Assignments

Each device on a SCSI bus must have a SCSI identifier (ID) that allows the server to recognize it. For more information, see “Set the SCSI ID or Arbitrated Loop Physical Address” on page 2-2.

## Installing, Removing, or Resetting a Drive on an Active SCSI Bus

You can attach a drive to an active SCSI bus. However, the preferred and safest method of adding, removing, or resetting a drive is to power-off the system.

To add, remove, or reset a drive on an active SCSI bus:

1. Quiesce all drives on the SCSI bus. The drive to be added, removed, or reset must not be involved in any bus activity.
2. Disconnect power to the drive.
3. Connect (to install) or disconnect (to remove or reset) the SCSI bus cables to or from the drive’s SCSI connector. Ensure that the SCSI bus remains intact from the server (initiator) to the terminator throughout the connection or disconnection process.

**Note:** Changing or moving the terminator disrupts the continuity of the SCSI bus and interrupts any process on the bus. Ensure the proper terminator is being used.

---

## Fibre Channel Interface



**Attention:** A Class I laser assembly, in the optical transceiver, is mounted on the Ultrium Fibre Channel electronics card. This laser assembly is registered with the Department of Health and Human Services and is in compliance with IEC825.

To communicate with a server, the drive has one Fibre Channel interface (also called a *port*). In accordance with the standards of the American National Standards Institute (ANSI), the port runs Fibre Channel Protocol (which includes SCSI commands on the Fibre Channel) with ANSI-defined Fibre Channel Tape Support. The method by which the drive and server communicate is determined by the type of topology in which they reside and the type of connection that you choose.

## Supported Topologies

The drive can be attached either directly to a switch as a public device (switched fabric) or directly to a host bus adapter (HBA) as a private device. It can do so in a Point-to-Point topology (through an F\_port) or Arbitrated Loop topology (through an L\_port or FL\_port).

Unless you set the drive to force an explicit configuration (by using the FC configuration/status connector; see “Change the Link Services of the Drive (optional)” on page 2-9), the drive automatically configures to an L\_port or an N\_port when it boots. The type of port to which it configures depends on whether the drive recognizes the connection as a loop or a point-to-point connection:

- An L\_port supports a Fibre Channel Arbitrated Loop connection to an NL\_port or FL\_port.
- An N\_port supports direct connection to another N\_port or to an F\_port (for example, a director-class switch) in a point-to-point topology.

Regardless of the port to which you connect the drive, it automatically configures to a public device (through an F\_port or FL\_port to a switch) or to a private device (through an L\_port by using direct attachment to a server).

Table 1-2 lists the topologies in which the drive can operate, the Fibre Channel server connections that are available, and the port through which communication must occur.

*Table 1-2. Choosing the port for your topology and Fibre Channel connection*

Type of Topology	Type of Fibre Channel Connection to Server	
	Direct Connection(Private)	Switched Fabric(Public)
Fibre Channel-Arbitrated Loop(can be Two-Node Arbitrated Loop or Two-Node Switched Fabric Loop; is limited to two nodes)	L_Port	FL_Port
Switched fabric(two nodes)	N/A	F_Port

## Physical Characteristics

The drive attaches to Open Systems servers by using short-wave, multimode fiber optic cables. All cables feature LC-duplex connectors and are designated as 50/125 (50 refers to the diameter of the optical fiber and 125 refers to the diameter of the cable; both are measured in micrometers).

## Speed

The drive's Fibre Channel interface facilitates data at 4Gb/s (400 MB/s). It automatically negotiates to a rate of 2 GB/s (200 MB/s) or 1 Gb/s (100 MB/s) if the system or switch to which it connects does not support the 4-Gb rate (if this is the case, you may experience performance degradation). You can force the drive to an explicit speed by placing jumpers on the Fibre Channel (FC) configuration/status connector. For more information, see "Change the Link Services of the Drive (optional)" on page 2-9.

## Address Assignments

Each device on a Fibre Channel loop must have a Loop Identifier (LID) and a corresponding Arbitrated Loop Physical Address (AL\_PA) to communicate with other devices in the topology. The AL\_PA identifies the device on the loop. (LIDs and their corresponding AL\_PAs are listed in Table 2-1 on page 2-5 and Table 2-2 on page 2-7). You can set an AL\_PA by using one of two methods known as *soft addressing* or *hard addressing*.

Soft addressing allows the drive to dynamically arbitrate the AL\_PA with other Fibre Channel devices on the loop. Hard addressing allows you to choose the LID, which determines the corresponding AL\_PA. The higher the AL\_PA, the lower the priority of the device.

Generally, servers (initiators) require that devices use hard addressing; they do not support soft addressing. When setting addresses, assign the lowest AL\_PA (and thus the highest priority) to the server; assign the highest AL\_PA (and thus the lowest priority) to the drive.

To set soft or hard addressing, you must place jumpers on designated pins in the drive's LID/status connector (see **3** in Figure 1-4 on page 1-3). The pin configuration for soft and hard addressing is defined in "Setting the Arbitrated Loop Physical Address (Fibre Channel Drive Only)" on page 2-4.

## World Wide Names

Each drive has an 8-byte World Wide Node Name and an 8-byte World Wide Port Name that is assigned by IBM Manufacturing. The World Wide Node Name identifies the drive's SCSI logical unit; the World Wide Port Name identifies the physical port on the drive. An enclosure queries the World Wide Names through the LDI or RS-422 interface; a server queries the Names through the Fibre Channel interface. The drive reports the World Wide Names to switches. You can use the World Wide Node Name or World Wide Port Name to uniquely identify the drive on a SAN.

When your drive is installed in a tape library, you can change the World Wide Node Name and World Wide Port Name through the LDI (RS-422) interface. For instructions, refer to the documentation for your tape library.

## Installing, Removing, or Resetting a Drive on an Active Fibre Channel

A Fibre Channel network supports dynamic drive attachment. When adding, removing, or resetting a drive on an active server or SAN, perform the following steps:

1. Quiesce the drive. The drive to be added, removed, or reset must not be involved in activity.

2. Connect or disconnect the Fibre Channel cables to or from the drive.

---

## SAS Interface

A drive with a SAS (Serial Attached SCSI) interface can be linked directly to controllers. SAS is a performance improvement over traditional SCSI because SAS enables multiple devices (up to 128) of different sizes and types to be connected simultaneously with thinner and longer cables; its full-duplex signal transmission supports 3.0 Gb/s. In addition, SAS drives can be hot-plugged.

SAS drives will auto-negotiate speed. There are no configurable topologies thus no feature switches associated with SAS.

## Physical Characteristics

The drive contains a dual-port, SFF-8482 SAS connector. . The SAS connector conforms to the Device Free (Plug) Connector form of the SFF-8482 standard “Unshielded Dual Port Serial Attachment Connector” as defined by the SFF standards body. For more information go to <http://www.sffcommittee.org> or see <ftp://ftp.seagate.com/sff/SFF-8482.pdf> for connector details.

---

## Specifications

The sections below give the physical, power, and environmental specifications for the drive. Specifications for tape cartridges are given in “Environmental and Shipping Specifications for Tape Cartridges” on page 4-16.

### Physical Specifications

Specification	Measurement
Width	146.0 mm (5.75 in.) without bezel
	148.3 mm (5.84 in.) with bezel
Length	205.5 mm (8.09 in.) without bezel
	210.5 mm (8.29 in.) with bezel
Height	82.5 mm (3.25 in.) without bezel
	84.8 mm (3.34 in.) with bezel
Weight (without a cartridge)	3 kg (6 lb 10 oz)

### Power Specifications

Power Supply	5 V dc	12 V dc
Tolerance	10%	10%
Voltage Ripple/Noise(50 Hz - 20 MHz)	60 mV pp	125 mV pp
Minimum Supply Current (steady state) U160 SCSI	1.3 A	0.2 A
Minimum Supply Current (steady state) U320 SCSI, FC, and SAS	1.9 A	0.2 A
Maximum Supply Current (steady state) U160 SCSI	2.8 A	1.1 A
Maximum Supply Current (steady state) U320 SCSI, FC, and SAS	3.4 A	1.1 A

<b>Power Supply</b>	<b>5 V dc</b>	<b>12 V dc</b>
Peak Supply Current (instantaneous power by power supply) U160 SCSI	3.0 A for 100 ms (15 W)	4.10 A for 2 ms (49.20 W)
Peak Supply Current (instantaneous power by power supply) U320 SCSI, FC, and SAS	3.6 A for 100 ms (18 W)	4.10 A for 2 ms (49.20 W)

<b>Power Measurements</b>	<b>Ultra-160 SCSI drive</b>	<b>FC-4 Ultra-320, Fibre Channel or SAS drive</b>
Idle Mode (no cartridge)	9.5 W	12.5 W
Idle Mode (Cartridge loaded)	11.5 W	14.5 W
Reading and Writing	26.5 W	29.5 W

## Environmental Specifications

<b>Environmental Factor</b>	<b>Operating(see Note 3)</b>	<b>Storage</b>	<b>Shipping</b>
Drive temperature	10 to 40°C (50 to 104°F)	-40 to 60°C (-40 to 140°F)	-40 to 60°C (-40 to 140°F)
Relative humidity	20 to 80% 26 deg C wet bulb max.	10 to 90% noncondensing	10 to 90% noncondensing
<b>Note:</b> Measured in front of the bezel, near the air intake area (refer to Figure 2-1 on page 2-2).			

## Other Specifications

Maximum altitude	3048 m (10,000 ft) for operating and storage
	12192 m (40,000 ft) for shipping
Cartridge extraction force	250 to 750 gms-force

---

## Chapter 2. Installing the Drive

Depending on the type of enclosure, installation procedures may vary. Refer to the enclosure documentation for drive installation. The following generic procedure can be used if the enclosure documentation is not available .

---

### Avoiding Drive Damage

To avoid static electricity damage when handling the drive, use the following precautions:

- Limit your movement. Movement can cause static electricity to build around you.
- Always handle the drive carefully. Never touch exposed circuitry.
- Prevent others from touching the drive.
- Before unpacking and installing the drive into an enclosure, touch its static-protective packaging to an unpainted metal surface on the enclosure for at least two seconds. This reduces static electricity in the packaging and your body.
- When possible, remove the drive from its static-protective packaging and install it directly into an enclosure without setting it down. When this is not possible, place the drive's packaging on a smooth, level surface and place the drive on the packaging.
- Do not place the drive on the cover of the enclosure or on any other metal surface.

---

### Installation Overview

1. "Unpack the Drive"
2. "Power Off the Enclosure" on page 2-2
3. "Set the SCSI ID or Arbitrated Loop Physical Address" on page 2-2
4. "Set the Library Interface Protocol" on page 2-10
5. "Mount the Drive into an Enclosure" on page 2-10
6. "Connect and Test Power to the Drive" on page 2-11
7. "Connect the Internal Cable" on page 2-12
8. "Connect the Library Interface RS-422 Cable (optional)" on page 2-12
9. "Run Drive Diagnostics" on page 2-12
10. "Install Device Drivers" on page 2-12
11. "Connect the Enclosure's External SCSI, SAS, or Fibre Channel Interface to the Server" on page 2-13
12. "Configure the Drive to the Server, Switch, or Hub" on page 2-13

---

### Unpack the Drive

Unpack the drive and store the packaging for future moves or shipping.

### Acclimate the Drive and Media

Acclimation time is required if the temperature of the drive and media when unpacked is different than the temperature of its operating environment (measured

at the front of the bezel near the air intake area as shown in Figure 2-1). The recommended acclimation time is four hours after the drive has been unpacked or one hour after any condensation that you can see has evaporated, whichever is greater. When acclimating the drive, apply the following measures:

- If the drive is colder than its operating environment and the air contains sufficient humidity, condensation may occur in the drive and damage it. When the drive has warmed to the operating temperature range (greater than 10°C or 50°F) and no danger of condensation is present (the air is dry), warm the drive more quickly by powering it on for 30 minutes. Use a diagnostic tape to test the drive before inserting a tape that contains data.
- If the drive is hotter than its operating environment, the tape can stick to the drive head. When the drive has cooled to the operating temperature range (less than 40°C or 104°F), cool the drive more quickly by applying airflow for 30 minutes. Power-on the drive and use a diagnostic tape to test it before inserting a tape that contains data.

If you are uncertain about whether the temperature of the drive is within the recommended operating range or the humidity is sufficient to cause condensation, acclimate the drive for the full four hours.

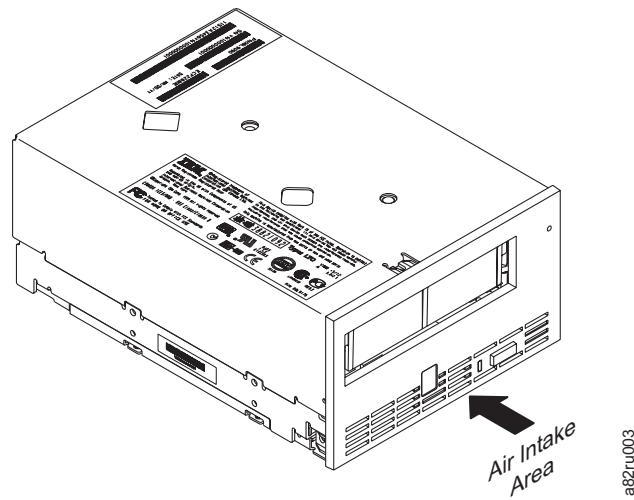

Figure 2-1. Temperature of the drive is taken near the air intake area

---

## Power Off the Enclosure

1. Power-off the enclosure (or the unit that provides power to the drive)
2. Disconnect the power cord from both the electrical outlet and the enclosure.

---

## Set the SCSI ID or Arbitrated Loop Physical Address

See instructions in the sections that follow to set a SCSI ID for a SCSI drive or an Arbitrated Loop Physical Address for a Fibre Channel drive.

### Setting the SCSI ID (SCSI Drive Only)

You can set the SCSI ID in one of three ways:

- By placing jumpers on the SCSI ID connector
- By using a SCSI ID switch that is connected to the SCSI ID connector



- By issuing a command from the library to set the SCSI ID through the drive's LDI interface

## Setting the SCSI ID with Jumpers

The SCSI ID can be set on the drive by installing 2 mm jumpers on the drive's SCSI ID connector (see **3** in Figure 1-3 on page 1-3 ). Your drive may come set to a default SCSI configuration, with jumpers already installed. To change the default SCSI configuration, contact your sales or technical support representative. You can change the SCSI ID by rearranging, adding, or removing jumpers.

### To set the SCSI ID:

1. Locate the SCSI ID connector (see **3** in Figure 1-3 on page 1-3 ).
2. Before attaching the SCSI bus cable to the server, determine the SCSI ID. Make sure that the ID is not being used by another device.
3. Referring to Figure 2-2, find the ID number that you chose then place jumpers on the connector pins as shown (use a pair of needle-nose pliers to connect the jumpers to the pins that are shaded).

**Note:** If you set the SCSI ID to 15, the drive will not necessarily be set to that ID; instead, the drive will expect to receive the SCSI ID through a command over its LDI interface.

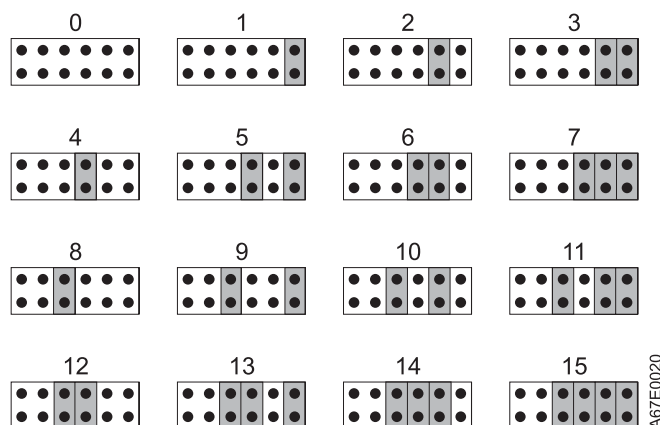

Figure 2-2. SCSI ID settings on the SCSI ID connector

## Setting the SCSI ID with a SCSI ID Switch

If your enclosure uses a SCSI ID switch (rather than jumpers), connect the switch to the drive's SCSI ID connector (see **3** in "Rear Panel of the SCSI Drive" on page 1-3). If any jumpers are preinstalled, be sure to remove them before connecting the switch. The SCSI ID switch must be compatible with the drive's SCSI ID connector and must make an electrical connection between the same pins as the jumpers to achieve the same corresponding SCSI ID.

## Setting the SCSI ID through the LDI Interface

If the drive is being installed into a tape library, a command can be issued from the library to set the drive's SCSI ID through the LDI interface. Make sure that the SCSI ID is set to 15 (see Figure 2-2). When configured to accept its SCSI ID through the LDI interface, the drive does not respond to SCSI commands until it receives a SET™ CONFIGURATION command through the interface.

## Supplying TERMPPOWER (SCSI Drive Only)

To supply TERMPPOWER to the bus, locate one of the five jumpers shipped with the drive and place it on the SCSI ID connector as shown in the following figure. Place the jumper on the pins that are shaded.

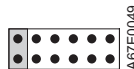

**Note:** SCSI termination must be provided externally to the drive.

## Setting the Arbitrated Loop Physical Address (Fibre Channel Drive Only)

Each device on a Fibre Channel loop must have an Arbitrated Loop Physical Address (AL\_PA) to communicate. The AL\_PA identifies the device on the loop. To set the drive's AL\_PA, you must place jumpers on specific pins in the drive's loop identifier (LID)/status connector. The placement of the jumpers indicates whether you want to choose the LID yourself (each LID corresponds to a specific AL\_PA) or whether you want the drive to choose the AL\_PA by arbitrating it with other devices on the loop. Valid LIDs and their corresponding AL\_PAs are provided in this section.

**Note:** A Loop ID is part of a contiguous range of values; valid AL\_PA values are not in a contiguous range.

In addition to establishing the AL\_PA, by moving Feature Switch 3 on the drive to ON or off you can set the drive so that it provides one of the following functions:

- Status about the Fibre Channel loop (through the use of external indicators in an enclosure)
- Additional LIDs

The sections that follow describe how to select the AL\_PA. They also describe how to set Feature Switch 3 so that the drive gives status about the loop or provides additional LIDs.

### Setting the Loop ID to Provide Status About the Loop

If Feature Switch 3 on the drive is set to OFF (see **1** in Figure 2-3 on page 2-5), the LID/status connector **2** has the following definition:

- Pins 1, 2, 3, 4, 7, and 8 are inputs and are used to set the LID.
- Pins 5 and 6 are used as outputs:
  - Pin 5 has three states: *off* (ground), *on* (3.3 V), and *alternating* (between off and on). Pin 5 will be off if the drive does not detect light on the Fibre Channel connector, if (while communicating as an L\_port) the drive does not complete the Loop Initialization Protocol (LIP), or if (while communicating as an N\_port) the drive does not complete logging in to the host or switch. Pin 5 will be on if the drive detects light, successfully completes the LIP process, or logs in to another port. After the drive has completed the LIP process, the pin will be alternating when the drive is receiving SCSI commands, and the pin will be on when the drive is not receiving SCSI commands.
  - Pin 6 indicates that the drive detects light. If pin 6 is on but pin 5 is off, this could indicate communication problems across the fiber cable.

- If the drive is installed in an enclosure, pins 5 and 6 may be used to support external indicators, such as light-emitting diodes (LEDs), on the enclosure.

**Note:** If indicators are used on an enclosure, the drive does not report error codes 8 and F (Fibre Channel problems) to the single-character display. Instead, pins 5 and 6 signal to the indicators that there is a problem.

- Pin 9 is ground.

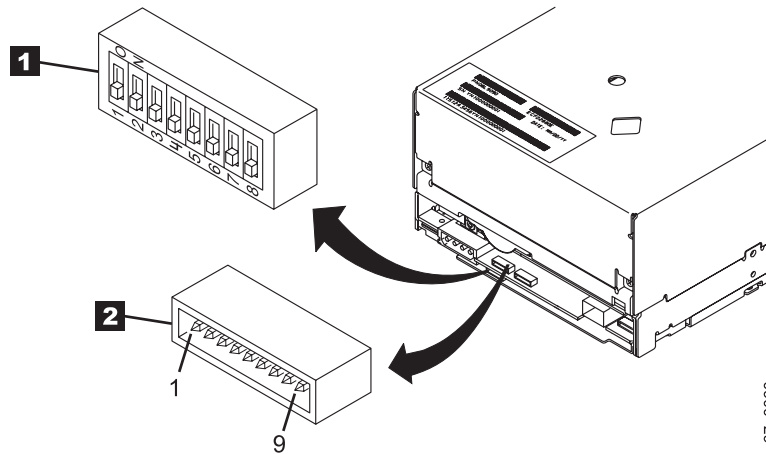

Figure 2-3. Setting the Loop ID and the AL\_PA. The feature switches are located on the bottom of the drive.

**To set the AL\_PA:**

1. Determine an unused AL\_PA for the drive and refer to Table 2-1 for its corresponding LID.
2. Locate the LID/status connector on the drive (see **2** in Figure 2-3).
3. Place jumpers on pins 1, 2, 3, 4, 7, and 8 as shown in Table 2-1.

By using hard addressing, you can specify one of 62 valid AL\_PAs for the drive. If you place jumpers on the four top and bottom pins on the right (a total of eight pins), the drive gets the AL\_PA from a field in its vital product data (VPD). (A tape library can set the AL\_PA in the VPD through the LDI interface.) If you do not place jumpers on any pins, the drive uses soft addressing to determine the AL\_PA.

Table 2-1. ID Settings that provide status about the loop. The table lists the AL\_PAs, corresponding LIDs, and definitions of the jumpers on the connector pins. Feature Switch 3 must be set to OFF.

AL_PA	LID	Pin(see Notes)						AL_PA	LID	Pin(see Notes)						
		1	2	3	4	7	8			1	2	3	4	7	8	
use soft addressing	0	-	-	-	-	-	-	B2	20	G	-	-	-	-	-	-
E8	1	-	-	-	-	-	G	B1	21	G	-	-	-	-	-	G
E4	2	-	-	-	-	G	-	AE	22	G	-	-	-	G	-	
E2	3	-	-	-	-	G	G	AD	23	G	-	-	-	G	G	
E1	4	-	-	-	G	-	-	AC	24	G	-	-	G	-	-	
E0	5	-	-	-	G	-	G	AB	25	G	-	-	G	-	G	
DC	6	-	-	-	G	G	-	AA	26	G	-	-	G	G	-	
DA	7	-	-	-	G	G	G	A9	27	G	-	-	G	G	G	
D9	8	-	-	G	-	-	-	A7	28	G	-	G	-	-	-	

Table 2-1. ID Settings that provide status about the loop (continued). The table lists the AL\_PAs, corresponding LIDs, and definitions of the jumpers on the connector pins. Feature Switch 3 must be set to OFF.

AL_PA	LID	Pin(see Notes)					
		1	2	3	4	7	8
D6	9	-	-	G	-	-	G
D5	A	-	-	G	-	G	-
D4	B	-	-	G	-	G	G
D3	C	-	-	G	G	-	-
D2	D	-	-	G	G	-	G
D1	E	-	-	G	G	G	-
CE	F	-	-	G	G	G	G
CD	10	-	G	-	-	-	-
CC	11	-	G	-	-	-	G
CB	12	-	G	-	-	G	-
CA	13	-	G	-	-	G	G
C9	14	-	G	-	G	-	-
C7	15	-	G	-	G	-	G
C6	16	-	G	-	G	G	-
C5	17	-	G	-	G	G	G
C3	18	-	G	G	-	-	-
BC	19	-	G	G	-	-	G
BA	1A	-	G	G	-	G	-
B9	1B	-	G	G	-	G	G
B6	1C	-	G	G	G	-	-
B5	1D	-	G	G	G	-	G
B4	1E	-	G	G	G	G	-
B3	1F	-	G	G	G	G	G

AL_PA	LID	Pin(see Notes)					
		1	2	3	4	7	8
A6	29	G	-	G	-	-	G
A5	2A	G	-	G	-	G	-
A3	2B	G	-	G	-	G	G
9F	2C	G	-	G	G	-	-
9E	2D	G	-	G	G	-	G
9D	2E	G	-	G	G	G	-
9B	2F	G	-	G	G	G	G
98	30	G	G	-	-	-	-
97	31	G	G	-	-	-	G
90	32	G	G	-	-	G	-
8F	33	G	G	-	-	G	G
88	34	G	G	-	G	-	-
84	35	G	G	-	G	-	G
82	36	G	G	-	G	G	-
81	37	G	G	-	G	G	G
80	38	G	G	G	-	-	-
7C	39	G	G	G	-	-	G
7A	3A	G	G	G	-	G	-
79	3B	G	G	G	-	G	G
76	3C	G	G	G	G	-	-
75	3D	G	G	G	G	-	G
74	3E	G	G	G	G	G	-
use AL_PA from VPD	3F	G	G	G	G	G	G

**Note:**

1. G means that the pin is jumpered to ground.
2. - means that the pin is not jumpered.

## Setting the Loop ID to Provide Additional Loop IDs

If Feature Switch 3 on the drive is set to 0N (see **1** in Figure 2-3 on page 2-5), the LID/status connector **2** has the following definition:

- Pins 1 through 7 are used to set the LID.
- Pin 8 overrides pins 1 through 7. If you place a jumper on pin 8, the drive uses its vital product data (VPD) to set the AL\_PA. A tape library can set the AL\_PA in VPD through the LDI interface.
- Pin 9 is ground.

**Note:** Feature Switch 3 does not support LEDs on an enclosure. Therefore, when Feature Switch 3 is set to 0N, the drive can report Fibre Channel problems (error codes 8 and F) on the single-character display, but not by using the enclosure's external indicators.

**To set the AL\_PA:**

1. Determine an unused AL\_PA address for the drive and refer to Table 2-2 for its corresponding LID.
2. Locate the LID/status connector on the drive (see **2** in Figure 2-3 on page 2-5).
3. Place jumpers on pins 1 through 7 as shown in Table 2-2 or on pin 8.

*Table 2-2. ID settings that provide additional Loop IDs.* The table lists the AL\_PAs, corresponding LIDs, and definitions of the jumpers on the connector pins. Feature Switch 3 must be set to 0N.

AL_PA	LID	Pin(see Notes)						
		1	2	3	4	5	6	7
EF	0	-	-	-	-	-	-	-
E8	1	-	-	-	-	-	-	G
E4	2	-	-	-	-	-	G	-
E2	3	-	-	-	-	-	G	G
E1	4	-	-	-	-	G	-	-
E0	5	-	-	-	-	G	-	G
DC	6	-	-	-	-	G	G	-
DA	7	-	-	-	-	G	G	G
D9	8	-	-	-	G	-	-	-
D6	9	-	-	-	G	-	-	G
D5	A	-	-	-	G	-	G	-
D4	B	-	-	-	G	-	G	G
D3	C	-	-	-	G	G	-	-
D2	D	-	-	-	G	G	-	G
D1	E	-	-	-	G	G	G	-
CE	F	-	-	-	G	G	G	G
CD	10	-	-	G	-	-	-	-
CC	11	-	-	G	-	-	-	G
CB	12	-	-	G	-	-	G	-
CA	13	-	-	G	-	-	G	G
C9	14	-	-	G	-	G	-	-
C7	15	-	-	G	-	G	-	G
C6	16	-	-	G	-	G	G	-
C5	17	-	-	G	-	G	G	G
C3	18	-	-	G	G	-	-	-
BC	19	-	-	G	G	-	-	G
BA	1A	-	-	G	G	-	G	-
B9	1B	-	-	G	G	-	G	G
B6	1C	-	-	G	G	G	-	-
B5	1D	-	-	G	G	G	-	G
B4	1E	-	-	G	G	G	G	-
B3	1F	-	-	G	G	G	G	G
B2	20	-	G	-	-	-	-	-
B1	21	-	G	-	-	-	-	G
AE	22	-	G	-	-	-	G	-
AD	23	-	G	-	-	-	G	G
AC	24	-	G	-	-	G	-	-
AB	25	-	G	-	-	G	-	G
AA	26	-	G	-	-	G	G	-
A9	27	-	G	-	-	G	G	G
A7	28	-	G	-	G	-	-	-
A6	29	-	G	-	G	-	-	G
A5	2A	-	G	-	G	-	G	-
A3	2B	-	G	-	G	-	G	G
9F	2C	-	G	-	G	G	-	-
9E	2D	-	G	-	G	G	-	G
9D	2E	-	G	-	G	G	G	-
9B	2F	-	G	-	G	G	G	G
98	30	-	G	G	-	-	-	-
97	31	-	G	G	-	-	-	G
90	32	-	G	G	-	-	G	-
8F	33	-	G	G	-	-	G	G
88	34	-	G	G	-	G	-	-
84	35	-	G	G	-	G	-	G
82	36	-	G	G	-	G	G	-
81	37	-	G	G	-	G	G	G
80	38	-	G	G	G	-	-	-
7C	39	-	G	G	G	-	-	G
7A	3A	-	G	G	G	-	G	-
79	3B	-	G	G	G	-	G	G
76	3C	-	G	G	G	G	-	-
75	3D	-	G	G	G	G	-	G
74	3E	-	G	G	G	G	G	-
73	3F	-	G	G	G	G	G	G
72	40	G	-	-	-	-	-	-
71	41	G	-	-	-	-	-	G

Table 2-2. ID settings that provide additional Loop IDs (continued). The table lists the AL\_PAs, corresponding LIDs, and definitions of the jumpers on the connector pins. Feature Switch 3 must be set to 0N.

AL_PA	LID	Pin(see Notes)						
		1	2	3	4	5	6	7
6E	42	G	-	-	-	-	G	-
6D	43	G	-	-	-	-	G	G
6C	44	G	-	-	-	-	G	-
6B	45	G	-	-	-	G	-	G
6A	46	G	-	-	-	G	G	-
69	47	G	-	-	-	G	G	G
67	48	G	-	-	G	-	-	-
66	49	G	-	-	G	-	-	G
65	4A	G	-	-	G	-	G	-
63	4B	G	-	-	G	-	G	G
5C	4C	G	-	-	G	G	-	-
5A	4D	G	-	-	G	G	-	G
59	4E	G	-	-	G	G	G	-
56	4F	G	-	-	G	G	G	G
55	50	G	-	G	-	-	-	-
54	51	G	-	G	-	-	-	G
53	52	G	-	G	-	-	G	-
52	53	G	-	G	-	-	G	G
51	54	G	-	G	-	G	-	-
4E	55	G	-	G	-	G	-	G
4D	56	G	-	G	-	G	G	-
4C	57	G	-	G	-	G	G	G
4B	58	G	-	G	G	-	-	-
4A	59	G	-	G	G	-	-	G
49	5A	G	-	G	G	-	G	-
47	5B	G	-	G	G	-	G	G
46	5C	G	-	G	G	G	-	-
45	5D	G	-	G	G	G	-	G
43	5E	G	-	G	G	G	G	-
3C	5F	G	-	G	G	G	G	G
3A	60	G	G	-	-	-	-	-

AL_PA	LID	Pin(see Notes)						
		1	2	3	4	5	6	7
39	61	G	G	-	-	-	-	G
36	62	G	G	-	-	-	G	-
35	63	G	G	-	-	-	G	G
34	64	G	G	-	-	G	-	-
33	65	G	G	-	-	G	-	G
32	66	G	G	-	-	G	G	-
31	67	G	G	-	-	G	G	G
2E	68	G	G	-	G	-	-	-
2D	69	G	G	-	G	-	-	G
2C	6A	G	G	-	G	-	G	-
2B	6B	G	G	-	G	-	G	G
2A	6C	G	G	-	G	G	-	-
29	6D	G	G	-	G	G	-	G
27	6E	G	G	-	G	G	G	-
26	6F	G	G	-	G	G	G	G
25	70	G	G	G	-	-	-	-
23	71	G	G	G	-	-	-	G
1F	72	G	G	G	-	-	G	-
1E	73	G	G	G	-	-	G	G
1D	74	G	G	G	-	G	-	-
1B	75	G	G	G	-	G	-	G
18	76	G	G	G	-	G	G	-
17	77	G	G	G	-	G	G	G
10	78	G	G	G	G	-	-	-
0F	79	G	G	G	G	-	-	G
08	7A	G	G	G	G	-	G	-
04	7B	G	G	G	G	-	G	G
02	7C	G	G	G	G	G	-	-
01	7D	G	G	G	G	G	-	G
SA	7E	G	G	G	G	G	G	-
SA	7F	G	G	G	G	G	G	G

**Note:**

1. G means that the pin is jumpered to ground.
2. - means that the pin is not jumpered.
3. SA means soft addressing.

## Change the Link Services of the Drive (optional)

You can optionally change the link services (for example, the speed and type of topology) of your Fibre Channel drive. If you choose not to alter the link services, the drive defaults to a negotiated speed and operation in an FC-AL topology with a direct connection to the server.

In the following procedure, note that:

- Pin 5 is disconnected and is not represented in Table 2-3.
- Pin 9 is ground.

### To change the type of topology and the speed of the Fibre Channel drive:

1. Determine the type of topology in which you want to operate the drive and refer to Table 2-3 for its corresponding pin configuration.
2. Determine the speed at which you want the drive to operate and refer to Table 2-3 for its corresponding pin configuration.
3. Locate the Fibre Channel (FC) configuration/status connector on the drive (see **1** in Figure 2-4 on page 2-10.)
4. Place jumpers on the pins that you identified in steps 1 and 2.

Table 2-3. Topology and speed settings for the drive

Fibre Channel Characteristic	Pin				
	1	2	3	4	5 through 8
<b>Speed Selection</b>					
Drive uses VPD values that can be updated by the LDI or RS-422 (the default value is Negotiated)	-	-	X	X	X
4 Gb (400 MB/s)	-	G	X	X	X
2 Gb (200 MB/s)	-	G	X	X	X
1 Gb (100 MB/s)	G	-	X	X	X
Negotiated (the drive automatically negotiates to the highest common speed)	G	G	X	X	X
<b>Topology Selection</b>					
Drive uses VPD values that can be updated by the LDI or RS-422 (the default value is the NL_port)	X	X	-	-	X
L_Port	X	X	-	G	X
N_Port	X	X	G	-	X
NL_Port (the drive automatically selects and configures the topology)	X	X	G	G	X
<b>Note:</b>					
1. G means that the pin is jumpered to ground.					
2. - means that the pin is not jumpered.					
3. X means that the setting of the pin does not matter.					

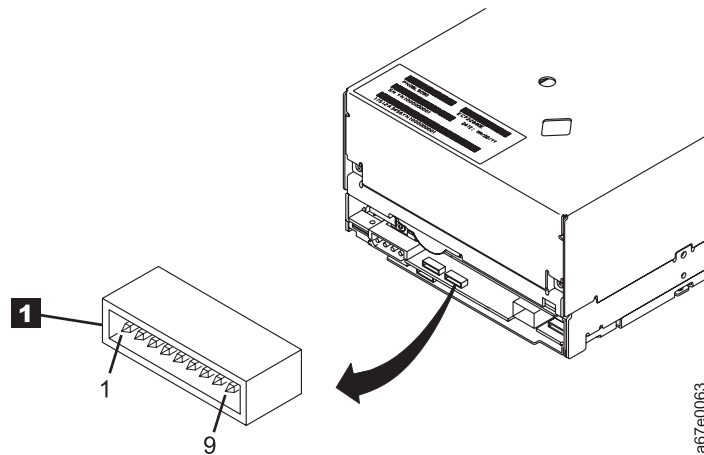

Figure 2-4. Location of the Fibre Channel (FC) configuration/status connector. The view is from the rear of the drive.

---

## Set the Library Interface Protocol

To specify the protocol for the library interface, set Feature Switch 5. When Feature Switch 5 is ON, the drive supports ADI. When Feature Switch 5 is OFF, the drive supports LDI.

---

## Choose Library Protocol

To specify the protocol for the library interface, set Feature Switch 5. When Feature Switch 5 is ON, the drive supports ADI. When Feature Switch 5 is OFF, the drive supports LDI.

---

## Mount the Drive into an Enclosure

The drive may be shipped with or without a front bezel (see **1** in Figure 2-5 on page 2-11).

### When mounting the drive:

- Use an appropriate screw length.
- Ensure that no objects such as screw heads, cables, or adjacent devices, are pressing against the frame.
- Do not obstruct the ventilation slots at the rear of the drive.
- Allow sufficient space for accessing the drive's front panel controls.

### To mount the drive into an enclosure:

1. Remove the cover of your enclosure (refer to the instructions in the documentation provided with your enclosure).
2. Place the drive into the enclosure so that the tape load compartment of the drive faces the tape load compartment of the enclosure.
3. Insert two M3 screws into the mounting holes **2** of the two side brackets located on the left and right sides of the chassis.



**Attention:** When inserted into the drive, the length of the mounting screws must not exceed 3.5 mm (0.14 in.) inside the chassis. If the length exceeds this measurement, the drive may become damaged.

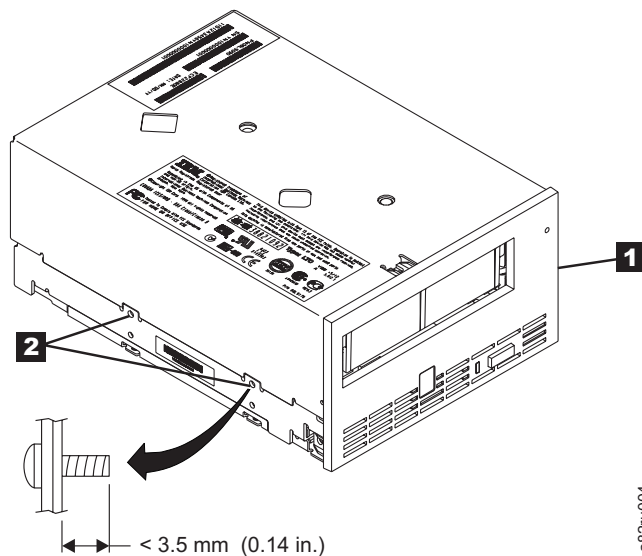

Figure 2-5. Mounting holes on drive. The holes are located on both sides of the drive. The drive is shown with a front bezel.

## Connect and Test Power to the Drive

The drive does not contain its own power source; it must be powered externally.

### To connect and test power to the drive:

1. Ensure that the enclosure (or unit that supplies power to the drive) is powered off.
2. Ensure that the power cord is disconnected from both the enclosure and the power outlet.
3. Connect the enclosure's internal power cable to the power connector on the drive (see **4** in Figure 1-3 on page 1-3 ).
4. Connect the power cord to the enclosure and to the electrical outlet.
5. Review the location of the Single-character Display (SCD) and the Status Light in Figure 1-2 on page 1-2 (if your drive does not have a bezel, note that the bulb of the Status Light is recessed and the light is not visible until lit). To ensure that the drive is receiving power, watch for the following while turning on the power to the enclosure:
  - During the power-on/initialization and POST (Power-On Self Test), the SCD briefly displays



, then becomes blank (not lit) when POST is complete and there are no POST errors. If a POST error has been detected, an error code will be displayed in the SCD and the Status Light will flash amber.

**Attention:** If the SCD does not come on, the drive may not be getting power.

- The Status Light will be OFF during the initial power-on and initialization. The Status Light briefly becomes green and then becomes amber during the remainder of the power-on and initialization phase. The Status Light becomes solid green after the power-on/initialization and POST are complete.
6. Power-off the enclosure.
  7. Disconnect the power cord from both the enclosure and the electrical outlet.

---

## Connect the Internal Cable

For SCSI or SAS drives, connect the enclosure's internal SCSI or SAS cable to the SCSI or SAS connector on the drive (see **2** in "Rear Panel of the SCSI Drive" on page 1-3 or **2** in Figure 1-5 on page 1-4).

If you are using a Fibre Channel drive, connect the enclosure's internal Fibre Channel cable to the Fibre Channel connector on the drive (see **5** in Figure 1-4 on page 1-3).

---

## Connect the Library Interface RS-422 Cable (optional)

**Note:** Use this step only if you are installing the drive into a library control system. The drive uses the LDI or ADI protocol to communicate with a tape library.

Connect the enclosure's internal library interface RS-422 cable to the RS-422 connector for library interfaces on the drive (see **5** in Figure 1-3 on page 1-3, **7** in Figure 1-4 on page 1-3 or **3** in Figure 1-5 on page 1-4).

---

## Run Drive Diagnostics

1. Replace the cover on the enclosure.
2. Connect the power cord to both the enclosure and the electrical outlet.
3. Power-on the enclosure.
4. Run one or more of the following drive diagnostics:
  - "Function Code 1: Run Drive Diagnostics" on page 3-8
  - "Function Code 6: Run Host Interface Wrap Test" on page 3-12
  - "Function Code 7: Run RS-422 Wrap Test" on page 3-14If an error code appears on the single-character display (SCD), go to Table 5-3 on page 5-3. If no error appears, continue to the next step.
5. Power-off the enclosure.
6. Disconnect the power cord from both the enclosure and the electrical outlet.

---

## Install Device Drivers

For information about installing device drivers, refer to the documentation for your enclosure.

---

## **Connect the Enclosure's External SCSI, SAS, or Fibre Channel Interface to the Server**

For information about connecting the enclosure, refer to the documentation for your enclosure.

---

## **Configure the Drive to the Server, Switch, or Hub**

To configure the drive to the server, refer to the documentation for that server, switch, or hub.

The drive is now ready for use.



---

## Chapter 3. Operating the Drive

Operating the drive involves using the following front panel items:

- Single-character Display (SCD)
- SCD Dot
- Status Light
- Unload Button

---

### Single-character Display (SCD)

The SCD ( **2** in Figure 1-2 on page 1-2) presents a single-character code for:

- Error conditions and informational messages
- Diagnostic or maintenance functions (while in maintenance mode only)

“Error Codes and Messages” on page 5-2 lists the codes for error conditions and informational messages. If multiple errors occur, the code with the highest priority (represented by the lowest number) displays first. When the error is corrected, the code with the next highest priority displays, and so on until no errors remain.

“Diagnostic and Maintenance Functions” on page 3-5 lists the single-character codes that represent diagnostic or maintenance functions. To initiate a function the unit must be in maintenance mode.

The SCD is blank during normal operation.

### SCD Dot

If a drive dump is present while the drive is in maintenance mode, a single red dot illuminates in the lower right corner of the SCD (  ). To copy the dump, see “Function Code 5: Copy Drive Dump” on page 3-11.

The SCD Dot is on solid if the dump is in ROM memory. The SCD Dot flashes if the dump is in FLASH memory.

The SCD Dot turns off when you obtain a dump (by using ITDT, a library command, a SCSI command, or “Function Code 5: Copy Drive Dump”) or update the drive firmware.

**Note:** If the drive dump is stored in ROM memory (SCD Dot on solid), the dump will be lost when you turn OFF the power or reset the drive.

---

### Status Light

The Status Light ( **4** in Figure 1-2 on page 1-2) is a light-emitting diode (LED) that provides information about the state of the drive. The light can be green or amber, and (when lit) solid or flashing. Table 3-1 on page 3-2 lists the conditions of the Status Light and Single-character Display (SCD) and provides an explanation of what each condition means.

Table 3-1. Meaning of Status Light and Single-character Display (SCD)







If the Status Light is...	and the SCD is...	Meaning
Off	Off	The drive has no power or is powered off.
Green	Off	The drive is powered on and in an idle state.
Flashing Green	Off	The drive is reading from the tape, writing to the tape, rewinding the tape, locating data on the tape, loading the tape, or unloading the tape.
Flashing Green	Off	The drive contains a cartridge during the power-on cycle. In this case, the drive completes POST and slowly rewinds the tape (the process may take up to ten minutes). The light stops blinking and becomes solid when the drive completes the recovery and is ready for a read or write operation. To eject the cartridge, press the unload button.
Flashing Amber	Displaying Error Code	The drive is displaying error code(s) from the error code log on the SCD. For more information, see "Function Code 9: Display Error Code Log" on page 3-15 and "Error Codes and Messages" on page 5-2
Amber	Red numbers, letters, or segments 	During the power-on/initialization and POST (Power-On Self Test), the SCD briefly displays  , then becomes blank (not lit) when POST is complete and there are no POST errors. If a POST error has been detected, an error code will be displayed in the SCD and the Status Light will flash amber.
Amber	Flashing 	The drive is exiting from maintenance mode. For more information, see "Function Code 0: Maintenance Mode" on page 3-8.
Amber	Flashing selected function	The drive is executing the selected function while in maintenance mode.
Flashing Amber once per second	Displaying error code	An error occurred and the drive or media may require service, or it may require cleaning. Note the code on the SCD, then go to "Error Codes and Messages" on page 5-2 to determine the action that is required.
Flashing Amber once per second	Displaying 	The drive needs cleaning.
Flashing Amber twice per second	Displaying Function Code  or Off	The drive is updating firmware. <sup>1</sup> The SCD will display a  if using an FMR cartridge. The SCD will be off if using the SCSI interface. For more information, see "Updating Firmware" on page 3-21.
Flashing Amber twice per second	Off	The drive detected an error and is performing a firmware recovery. It will reset automatically.
Flashing Amber twice per second	Flashing 	The drive is requesting a cartridge to be loaded.
Flashing Amber twice per second	Off	There is a drive dump in flash memory.

Table 3-1. Meaning of Status Light and Single-character Display (SCD) (continued)

If the Status Light is...	and the SCD is...	Meaning
<sup>1</sup> Power should not be removed from the drive until the microcode update is complete. The drive indicates that the update is complete by resetting and performing POST.		
<sup>2</sup> If a drive dump is present while the drive is in maintenance mode, a single red dot illuminates in the lower right corner of the SCD. Refer to "SCD Dot" on page 3-1.		

## Unload Button

The Unload Button (  in Figure 1-2 on page 1-2) performs the following functions:

Table 3-2. Functions that the Unload Button performs



Unload Button Function	How to Initiate the Function
Rewind the tape into the cartridge and eject the cartridge from the drive	Press the Unload Button once. The Status Light flashes green while the drive is rewinding and unloading. <b>Note:</b> During a rewind and eject operation, the drive does not accept SCSI commands from the server.
Place the drive in maintenance mode	Ensure that the drive is unloaded. Then, within two seconds, press the Unload Button three times. The drive is in maintenance mode when the Status Light becomes solid amber and  appears in the SCD. <b>Note:</b> While in maintenance mode, the drive does not accept SCSI interface commands.
Scroll through the maintenance functions	While in maintenance mode, press the Unload Button once per second to increment the display characters by one. When you reach the character of the diagnostic or maintenance function that you want (see "Diagnostic and Maintenance Functions" on page 3-5), press and hold the Unload Button for three seconds.
Exit maintenance mode	Press the Unload Button once per second until  displays. Then press and hold the Unload Button for three seconds. Maintenance mode is exited when the Status Light becomes solid green and the SCD becomes blank.
Force a drive dump (part of the maintenance mode)	<b>Attention:</b> If the drive detects a permanent error and displays an error code, it automatically forces a drive dump (also known as a save of the firmware trace). If you force a drive dump, the existing dump will be overwritten and data will be lost. After you force a drive dump, do not turn off the power to the drive or you may lose the dump data.  Choose one of the following procedures: <ul style="list-style-type: none"> <li>• If the drive is in maintenance mode (Status Light is solid amber), refer to "Function Code 4: Force a Drive Dump" on page 3-11.</li> <li>• If the drive is in operating mode (Status Light is solid or flashing green), press and hold the Unload Button for ten seconds.</li> </ul> If captured dump data exists, the drive places it into a dump area (for information about retrieving the data, see "Obtaining a Drive Dump" on page 5-13).

Table 3-2. Functions that the Unload Button performs (continued)

Unload Button Function	How to Initiate the Function
Reset the drive	Press and hold the Unload Button until the drive begins the reset procedure (SCD will display random patterns and the Status Light will be amber) <b>Note:</b> If a tape cartridge is loaded in the drive the drive will unload the tape. Repeat the "Reset the drive" procedure after the tape is unloaded. The drive saves a dump of the current drive state, then reboots to allow communication. Do not cycle power as this will erase the contents of the dump.

## Inserting a Tape Cartridge

To insert a tape cartridge:

1. Ensure that the drive is powered-on.
2. Ensure that the write-protect switch on the tape cartridge is properly set (see "Write-Protect Switch" on page 4-6).
3. Grasp the cartridge so that the write-protect switch faces you (see **1** in Figure 3-1).
4. Slide the cartridge into the tape load compartment.

**Note:**

- a. If the cartridge is already in an ejected position and you want to reinsert it, remove the cartridge then insert it again.
- b. If the cartridge is already loaded and you cycle the power (turn it off, then on), the tape will reload.
- c. Do not attempt to load a cartridge when the drive is in Maintenance Mode until the drive requests it.

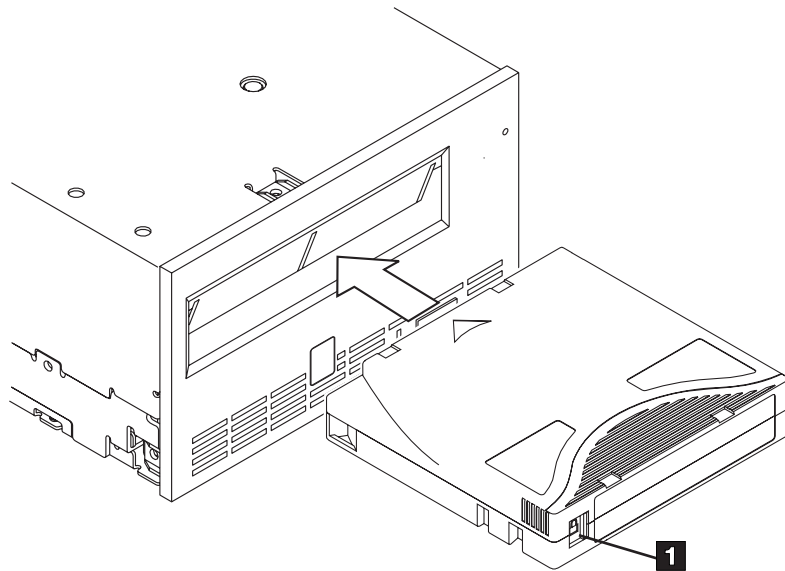

a82ru005

Figure 3-1. Inserting a cartridge into the drive



---

## Removing a Tape Cartridge

To remove a tape cartridge:

1. Ensure that the drive is powered-on.
2. Press the Unload Button. The drive rewinds the tape and partially ejects the cartridge. The Status Light flashes green while the tape rewinds, then goes out before the cartridge partially ejects.
3. After the cartridge partially ejects, grasp the cartridge and remove it.

Whenever you unload a tape cartridge, the drive writes any pertinent information to the cartridge memory.

---

## Mid-tape Recovery

If reset occurs while a cartridge is loaded, the drive will slowly rewind the tape and eject the cartridge. If a power cycle occurs while a cartridge is loaded, the drive will slowly rewind the tape. The drive will not automatically eject the cartridge.

---

## Cleaning the Drive Head

**Attention:** When cleaning the drive head, use the IBM LTO Ultrium Cleaning Cartridge (see “Ordering Media Supplies” on page 4-18). You may use another LTO cleaning cartridge, but it may not meet the standards of reliability established by IBM.

Clean the drive head whenever  displays on the Single-character Display and the Status Light is flashing amber once per second. It is not recommended that you clean the drive head on a periodic basis; only when the drive requests to be cleaned.

**Note:** In Maintenance Mode, a flashing  with the **solid** amber Status Light , means to insert a cartridge, not clean the drive head.

To clean the head, insert the cleaning cartridge into the tape load compartment (see “Front Panel of the Drive” on page 1-2). The drive performs the cleaning automatically in less than two minutes then ejects the cartridge. The drive will perform a short Load/Unload Test while ejecting the drive. Wait for the drive to finish before removing the cartridge.

**Note:** The drive will automatically eject an expired cleaning cartridge.

The IBM LTO Ultrium Cleaning Cartridge is valid for 50 uses.

---

## Diagnostic and Maintenance Functions

The drive can:

- Run diagnostics
- Test write and read functions
- Test a suspect tape cartridge

- Update firmware
- Perform other diagnostic and maintenance functions

The drive must be in maintenance mode to perform these functions.

**Attention:** Maintenance functions cannot be performed concurrently with read or write operations. While in maintenance mode, the tape drive does not accept SCSI commands from the server. The tape drive does accept LDI or RS-422 commands.

Table 3-3 describes each diagnostic and maintenance function that the drive can perform, gives the function code which appears on the Single-character Display (SCD), and directs you to the instructions for performing the function. It is recommended that you use a customer-supplied scratch (blank) data cartridge for diagnostic testing.

Table 3-3. Diagnostic and maintenance functions

Function Code	Diagnostic or Maintenance Function	Instructions Location
0	<b>Exit Maintenance Mode:</b> Causes the drive to become available for reading and writing data.	"Function Code 0: Maintenance Mode" on page 3-8
1	<b>Run Drive Diagnostics:</b> Runs tests to determine whether the drive can properly load and unload cartridges, and read and write data.	"Function Code 1: Run Drive Diagnostics" on page 3-8
2	<b>Update Tape Drive Firmware from FMR Tape:</b> Loads updated firmware from a field microcode replacement (FMR) tape.	"Function Code 2: Update Drive Firmware from FMR Tape" on page 3-9
3	<b>Create FMR Tape:</b> Copies its field microcode replacement (FMR) data to a customer-supplied scratch (blank) data cartridge.	"Function Code 3: Create FMR Tape" on page 3-10
4	<b>Force a Drive Dump:</b> Performs a dump of data (also known as saving a microcode trace).	"Function Code 4: Force a Drive Dump" on page 3-11
5	<b>Copy Drive Dump:</b> Copies data from a drive dump (captured by using Function Code 4) to the beginning of a customer-supplied scratch (blank) data cartridge, copies a drive dump to flash memory, or erases a dump from flash memory.	"Function Code 5: Copy Drive Dump" on page 3-11
6	<b>Run Host Interface Wrap Test:</b> Performs a check of the circuitry from and to the connector.	"Function Code 6: Run Host Interface Wrap Test" on page 3-12
7	<b>Run RS-422 Wrap Test:</b> This test causes the drive to perform a check of the circuitry and connector for the RS-422 interface.	"Function Code 7: Run RS-422 Wrap Test" on page 3-14
8	<b>Unmake FMR Tape:</b> Erases the FMR data on a customer-supplied scratch (blank) data cartridge and rewrite the cartridge memory on the tape. This turns the cartridge into a valid customer-supplied scratch data cartridge.	"Function Code 8: Unmake FMR Tape" on page 3-14
9	<b>Display Error Code Log:</b> Displays the last 10 error codes, one at a time (the codes are ordered; the most recent is presented first and the oldest (tenth) is presented last).	"Function Code 9: Display Error Code Log" on page 3-15
A	<b>Clear Error Code Log:</b> Erases the contents of the error code log.	"Function Code A: Clear Error Code Log" on page 3-15

Table 3-3. Diagnostic and maintenance functions (continued)

Function Code	Diagnostic or Maintenance Function	Instructions Location
C	<b>Insert Cartridge into Tape Drive:</b> This function cannot be selected by itself, but is a part of other maintenance functions (such as Run Tape Drive Diagnostics and Create FMR Tape) that require a tape cartridge to be loaded.	"Function Code C: Insert Cartridge into Tape Drive" on page 3-16
E	<b>Test Cartridge &amp; Media:</b> Performs tests to ensure that a suspect cartridge and its magnetic tape are acceptable.	"Function Code E: Test Cartridge & Media" on page 3-16
F	<b>Write Performance Test:</b> Performs tests to ensure that the drive can read from and write to tape.	"Function Code F: Write Performance Test" on page 3-17
H	<b>Test Head:</b> Performs tests to ensure that the tape drive's head and tape-carriage mechanics are working correctly.	"Function Code H: Test Head" on page 3-18
J	<b>Fast Read/Write Test:</b> Performs tests to ensure that the drive can read from and write to tape.	"Function Code J: Fast Read/Write Test" on page 3-19
L	<b>Load/Unload Test:</b> Tests the drive's ability to load and unload a tape cartridge.	"Function Code L: Load/Unload Test" on page 3-20
P	<b>Enable Post Error Reporting:</b> When selected, deferred-check conditions are reported to the host.	"Function Code P: Post Error Reporting Enabled" on page 3-20
U	<b>Disable Post Error Reporting:</b> When selected, deferred-check conditions are NOT reported to the host.	"Function Code U: Post Error Reporting Disabled" on page 3-21

## Entering Maintenance Mode

The drive must be in maintenance mode to run drive diagnostics or maintenance functions. To place the unit in maintenance mode:

1. Make sure that no cartridge is in the drive.
2. Press the Unload Button three times within two seconds.  appears in the Single-character Display (SCD), and the Status Light turns amber.

**Note:** If a cartridge is in the tape drive, it will eject the first time that you press the Unload Button and the drive will not be placed in maintenance mode. To continue placing the drive in maintenance mode, perform the preceding step.



Maintenance functions cannot be performed concurrently with read or write operations. While in maintenance mode, the drive does not receive SCSI commands from the server.

If a drive dump is present while the drive is in maintenance mode, a single red dot illuminates in the lower right corner of the SCD. Refer to "SCD Dot" on page 3-1.

## Exiting Maintenance Mode

The drive must be in Function Code  in order to exit Maintenance Mode.

To exit Maintenance Mode:

1. Press the Unload Button once per second until  appears in the SCD. (If you cycle past the desired code, press the Unload Button once per second until the code appears.)
2. Press and hold the Unload Button for three or more seconds, then release it. To exit Maintenance Mode when an error is displayed:
  1. Press the Unload Button three times within two seconds to clear the error code and return to Function Code .
  2. Press and hold the Unload Button for three or more seconds, then release it.

**Note:** The drive will exit Maintenance Mode automatically when:

- it completes a maintenance function
- if there is an error code for anything other than a hardware problem
- if no action has occurred for 10 minutes

The drive will not exit Maintenance Mode automatically if there is an error code displayed that indicates there is a hardware problem.

## Function Code 0: Maintenance Mode

Function Code  makes the drive available for running drive diagnostics or maintenance functions, or exiting from Maintenance Mode.

1. Place the drive in Maintenance Mode. For instructions, see "Entering Maintenance Mode" on page 3-7.
2. To exit Maintenance Mode, see "Exiting Maintenance Mode" on page 3-7.

The drive exits Maintenance Mode automatically after it completes a maintenance function or after 10 minutes if no action has occurred.

## Function Code 1: Run Drive Diagnostics

Approximate Run Time = 20 minutes per loop

Total Number of Loops = 10



Function Code  runs tests that determine whether the drive can properly load and unload cartridges and read and write data.





Press the Unload Button to stop the diagnostic and exit maintenance mode. Pressing the Unload Button once will abort the test at the end of the current test loop. Pressing the Unload Button twice will abort the test immediately. Wait for the drive to rewind the tape and unload the cartridge.

Once you begin this test, the diagnostic begins the loop sequence. Time the first loop by pressing the Unload Button once to stop the diagnostic after the completion of the first loop, then record the time it takes for the test to complete. Compare the recorded time with the "Approximate Run Time" above. If the test runs successfully but the execution time is significantly longer than the "Approximate Run Time", run "Function Code F: Write Performance Test" on page 3-17. If the Write Performance Test fails, replace the media and exit maintenance mode.

**Attention:** For this test, insert only a scratch (blank) data cartridge or a cartridge that may be overwritten. During the test, the drive overwrites the data on the cartridge.

**Note:** If you inserted an invalid tape cartridge (e.g. Gen1 or WORM media), error



code  appears in the SCD. If you inserted a write-protected cartridge, or the media has read-only compatibility (e.g., Gen2 media), error code  appears in the SCD. In either case, the tape drive unloads the cartridge and exits Maintenance Mode after the cartridge is removed.

1. Place the drive in Maintenance Mode. For instructions, see “Entering Maintenance Mode” on page 3-7.
2. Press the Unload Button once per second until  appears in the SCD. (If you cycle past the desired code, press the Unload Button once per second until the code reappears.)
3. Press and hold the Unload Button for three or more seconds, then release it to select function . Wait for the SCD to change to a flashing .
4. Insert a scratch (blank) data cartridge. The SCD changes to a flashing  and the test begins.
  - If no error is detected, the diagnostic will loop and begin again. To stop the loop, press the Unload Button for one second and release. When the loop ends,  temporarily appears in the SCD.
  - If an error is detected, the Status Light flashes amber and the drive posts an error code to the SCD. To determine the error, locate the code in Table 5-3 on page 5-3. To clear the error either turn the power off and then on again, or reboot the drive by pressing and holding the Unload Button for 10 seconds.

## Function Code 2: Update Drive Firmware from FMR Tape

**Attention:** When updating drive firmware, do not power-off the drive until the update is complete or the firmware may be lost.

Function Code  loads drive firmware from a field microcode replacement (FMR) tape. The FMR tape must have been created from a LTO Gen4 tape drive with the same host interface (SCSI U160, SCSI U320, SAS, or Fibre Channel).

1. Place the drive in Maintenance Mode. For instructions, see “Entering Maintenance Mode” on page 3-7.
2. Press the Unload Button once per second until  appears in the SCD. (If you cycle past the desired code, press the Unload Button once per second until the code reappears.)
3. Press and hold the Unload Button for three or more seconds, then release it to select the function. The SCD changes to a flashing .
4. Insert the FMR tape cartridge. The SCD changes to a flashing . The tape drive loads the updated firmware from the FMR tape into its erasable programmable read-only memory (EPROM) area.

- During the reboot the SCD presents a series of random characters. The SCD briefly displays **E**, then becomes blank (not lit) when POST is complete. The Status Lights will be amber during the reboot and change to green after a successful reboot.
- If the update completes successfully, the tape drive rewinds and unloads the FMR tape, resets itself, and is ready to use the new firmware. The drive automatically reboots.
- If the update fails, the tape drive posts an error code to the SCD. To determine the error, locate the code in Table 5-3 on page 5-3. The drive then unloads the FMR tape and exits maintenance mode after the cartridge is removed. Contact IBM Technical Support for problem determination or machine replacement.

### Function Code 3: Create FMR Tape

Function Code **3** copies the drive's field microcode replacement (FMR) data to a scratch data cartridge. The resulting FMR tape can only be used to update the firmware on other LTO Gen4 tape drives with the same host interface (SCSI U160, SCSI U320, SAS, or Fibre Channel).



**Attention:** For this function, insert only a scratch (blank) data cartridge or a cartridge that may be overwritten. During the test, the drive overwrites the data on the cartridge.

**Note:** If you inserted an invalid tape cartridge (e.g. Gen1 or WORM media), error code **7** appears in the SCD. If you inserted a write-protected cartridge, or the media has read-only compatibility (e.g., Gen2 media), error code **P** appears in the SCD. In either case, the tape drive unloads the cartridge and exits Maintenance Mode after the cartridge is removed.

1. Place the drive in Maintenance Mode. For instructions, see "Entering Maintenance Mode" on page 3-7.
2. Press the Unload Button once per second until **3** appears in the SCD. (If you cycle past the desired code, press the Unload Button once per second until the code reappears.)
3. Press and hold the Unload Button for three or more seconds, then release it to select the function. The SCD changes to a flashing **□**.
4. Insert a scratch (blank) data cartridge that is not write protected (or the tape drive exits maintenance mode). The SCD changes to a flashing **3**. The tape drive copies the FMR data to the scratch data cartridge.
  - If the tape drive creates the FMR tape successfully, it rewinds and unloads the new tape, exits Maintenance Mode, and the tape is ready to use.
  - If the tape drive fails to create the FMR tape, it displays an error code. To determine the error, see Table 5-3 on page 5-3. The tape drive then unloads the FMR tape, and exits Maintenance Mode after the cartridge is removed.

## Function Code 4: Force a Drive Dump

Function Code  performs a dump of data collected by the drive (this process is also known as saving a microcode trace).



1. Place the drive in Maintenance Mode. For instructions, see “Entering Maintenance Mode” on page 3-7. If a drive dump is present while the drive is in maintenance mode, a single red dot illuminates in the lower right corner of the SCD. Refer to “SCD Dot” on page 3-1. The SCD Dot is on solid if the dump is in ROM memory or flashes if the dump is in FLASH memory. If the drive dump is stored in ROM memory (SCD Dot on solid), the dump will be lost when you turn OFF the power or reset the drive. The SCD Dot turns off when you obtain a dump.
2. Press the Unload Button once per second until  appears in the SCD. (If you cycle past the desired code, press the Unload Button once per second until the code reappears.)
3. Press and hold the Unload Button for three or more seconds, then release it to select the function. The drive performs the dump. The SCD shows , then goes blank. To access the contents of the dump, see “Function Code 5: Copy Drive Dump.”

**Note:** You can also force a drive dump when the tape drive is in normal operating mode. Simply press and hold the Unload Button for ten seconds. This causes the drive to reboot.

## Function Code 5: Copy Drive Dump

Function Code  copies data from a drive dump (captured in Function Code 4) to the beginning of a scratch (blank) data cartridge.

**Attention:** For this function, insert only a scratch (blank) data cartridge or a cartridge that may be overwritten. During the test, the drive overwrites the data on the cartridge.

**Note:** If you inserted an invalid tape cartridge (e.g. Gen1 or WORM media), error code  appears in the SCD. If you inserted a write-protected cartridge, or the media has read-only compatibility (e.g., Gen2 media), error code  appears in the SCD. In either case, the tape drive unloads the cartridge and exits Maintenance Mode after the cartridge is removed.

1. Place the drive in Maintenance Mode. For instructions, see “Entering Maintenance Mode” on page 3-7. If a drive dump is present while the drive is in maintenance mode, a single red dot illuminates in the lower right corner of the SCD. Refer to “SCD Dot” on page 3-1. The SCD Dot is on solid if the dump is in ROM memory or flashes if the dump is in FLASH memory. If the drive dump is stored in ROM memory (SCD Dot on solid), the dump will be lost when you turn OFF the power or reset the drive. The SCD Dot turns off when you obtain a dump.



2. Press the Unload Button once per second until  $\boxed{5}$  appears in the SCD. If you cycle past the desired code, press the Unload Button once per second until the code reappears.

3. Press and hold the Unload Button for three or more seconds, then release it to select the function. Then press the Unload Button once per second to cycle through the following functions:

- $\boxed{5} - \boxed{0}$  : no function
- $\boxed{5} - \boxed{1}$  : copy dump to tape
- $\boxed{5} - \boxed{2}$  : copy dump to flash memory
- $\boxed{5} - \boxed{3}$  : erase flash memory

If you cycle past the desired code, press the Unload Button once per second until the code reappears.

4. Press and hold the Unload Button for three or more seconds, then release it to select one of the above functions.

5. If you selected  $\boxed{5} - \boxed{0}$  the drive will exit Maintenance Mode. If you selected  $\boxed{5} - \boxed{2}$  or  $\boxed{5} - \boxed{3}$  the SCD will change to a flashing  $\boxed{5}$  while the procedure is being performed. After the procedure is completed the drive will exit

Maintenance Mode. If you selected  $\boxed{5} - \boxed{1}$  the SCD will change to a flashing  $\boxed{C}$  indicating that a data cartridge is to be inserted.

6. Insert a scratch (blank) data cartridge that is not write protected (or the tape drive exits maintenance mode). The SCD flashes the selection number while performing the function.

- If the copy operation completes successfully, the tape drive rewinds and unloads the tape, and exits Maintenance Mode after the cartridge is removed.
- If the copy operation fails, an error code appears in the SCD. To determine the error, locate the code in Table 5-3 on page 5-3. The tape drive unloads the tape cartridge and exits Maintenance Mode after the cartridge is removed.

## Function Code 6: Run Host Interface Wrap Test

Approximate Run Time = 10 seconds per loop

Number of Loops = This test runs until stopped by pressing the Unload Button.

Function Code  $\boxed{6}$  performs a check of the host interface circuitry and host connector on the drive. The following IBM LTO Ultrium 4 tape drives support Function Code 6:

- Fibre Channel
- SAS
- SCSI U160

Function Code 6 is not supported on the SCSI U320. Function Code 6 is selectable on the SCSI U320 drive but the test will always exit with  $\boxed{0}$  on the SCD.



1. Make sure that the host interface wrap plug is connected to the host interface connector at the rear of the drive.
  - For SCSI drives, make sure the drive is terminated as follows:
    - Drive Connector - terminate on the connector at the rear of the drive, when attaching the wrap plug to the connector at the rear of the drive.
  - OR
    - End of Bus - disconnect the SCSI cable of the drive that is closest to the server, then attach the SCSI wrap plug to that SCSI connector.
  - For Fibre Channel drives, make sure the wrap plug is connected to an SFP in Port 0 (see Figure 1-4 on page 1-3).
  - For SAS drives, make sure a SFF-8482 SAS cable/connector is connected to the rear of the drive. Connect the wrap plug to the SFF-8482 SAS connector port to be tested.
2. Place the drive in Maintenance Mode. For instructions, see “Entering Maintenance Mode” on page 3-7.
3.
  - For SCSI or Fibre Channel drives,
    - a. Press the Unload Button once per second until  $\boxed{E}$  appears in the SCD. (If you cycle past the desired code, press the Unload Button once per second until the code reappears.)
    - b. Press and hold the Unload Button for three or more seconds, then release it to select the function. The drive automatically starts the test.
  - For SAS drives,
    - a. press the Unload Button once per second until  $\boxed{E}$  appears in the SCD.
    - b. Continue to press the Unload Button once per second to cycle through the following functions:
      - $\boxed{E}$  -  $\boxed{0}$  : exit
      - $\boxed{E}$  -  $\boxed{1}$  : test the primary SAS port
      - $\boxed{E}$  -  $\boxed{2}$  : test the secondary SAS port
      - $\boxed{E}$  -  $\boxed{3}$  : test both primary and secondary SAS ports at the same time (requires a wrap plug in both ports)
    - c. Press and hold the Unload Button for three or more seconds, then release it to select one of the above functions. The drive automatically starts the test. If you cycle past the desired code, press the Unload Button once per second until the code reappears.
4. The SCD will display a flashing  $\boxed{E}$  during the test.
  - If no error is detected, the diagnostic will loop and begin again. To stop the loop, press the Unload Button for one second and release. When the loop ends,  $\boxed{0}$  temporarily appears in the SCD.
  - If an error is detected, the Status Light flashes amber and the drive posts an error code to the SCD. To determine the error, locate the code in Table 5-3 on page 5-3. To clear the error either turn the power off and then on again, or reboot the drive by pressing and holding the Unload Button for 10 seconds.

## Function Code 7: Run RS-422 Wrap Test

This test causes the drive to perform a check of the circuitry and connector for the RS-422 interface. This connector supports the Library Drive Interface (LDI) and the Automation Drive Interface (ADI).

Before selecting this function, attach an LDI or RS-422 wrap plug to the drive's LDI or RS-422 connector (in place of the LDI or RS-422 cable).

1. Make sure that no cartridge is in the drive, and the appropriate wrap plug is attached to the RS-422 connector.
2. Place the drive in Maintenance Mode. For instructions, see "Entering Maintenance Mode" on page 3-7.
3. Press the Unload Button once per second until **7** appears in the Single-character Display (SCD). If you cycle past **7**, continue to press the Unload Button until it displays again.
4. To select the function, press and hold the Unload Button for three seconds.

After you select the function, **7** flashes and the drive automatically starts the test.

- If no error is detected, the diagnostic will loop and begin again. To stop the loop, press the Unload Button for one second and release. When the loop ends, **7** temporarily appears in the SCD.
- If an error is detected, the Status Light flashes amber and the drive posts an error code to the SCD. To determine the error, locate the code in Table 5-3 on page 5-3. To clear the error either turn the power off and then on again, or reboot the drive by pressing and holding the Unload Button for 10 seconds.

## Function Code 8: Unmake FMR Tape

Function Code **8** erases the field microcode replacement (FMR) data and rewrites the cartridge memory on the tape. This converts the cartridge into a valid scratch (blank) data cartridge.

1. Place the drive in maintenance mode. For instructions, see "Entering Maintenance Mode" on page 3-7.
2. Press the Unload Button once per second until **8** appears in the SCD. (If you cycle past the desired code, press the Unload Button once per second until the code reappears.)
3. Press and hold the Unload Button for three or more seconds, then release it to select function **8**. The SCD changes to a flashing **8**.
4. Insert the FMR data cartridge (or the tape drive exits maintenance mode). The SCD changes to a flashing **8**. The tape drive erases the firmware on the tape and rewrites the header in the cartridge memory to change the cartridge to a valid scratch (blank) data cartridge:

**Note:** If you inserted an invalid tape cartridge (e.g. Gen1 or WORM media), error code **7** appears in the SCD. If you inserted a write-protected

cartridge, or the media has read-only compatibility (e.g., Gen2 media),

error code **A** appears in the SCD. In either case, the tape drive unloads the cartridge and exits Maintenance Mode after the cartridge is removed.

- If no error is detected, the diagnostic will loop and begin again. To stop the loop, press the Unload Button for one second and release. When the loop ends, **A** temporarily appears in the SCD.
- If an error is detected, the Status Light flashes amber and the drive posts an error code to the SCD. To determine the error, locate the code in Table 5-3 on page 5-3. To clear the error either turn the power off and then on again, or reboot the drive by pressing and holding the Unload Button for 10 seconds.

## Function Code 9: Display Error Code Log

Function Code **9** displays the last ten error codes, one at a time (the codes are ordered; the most recent is presented first and the oldest is presented last). If there

are no errors in the log, function code **A** displays in the Single-character Display (SCD) and exits Maintenance Mode.

1. Place the drive in Maintenance Mode. For instructions, see “Entering Maintenance Mode” on page 3-7.
2. Press the Unload Button once per second until **9** appears in the SCD. (If you cycle past the desired code, press the Unload Button once per second until the code reappears.)
3. Press and hold the Unload Button for three or more seconds, then release it to view the most recent error code.
4. Press the Unload Button again to view successive error codes. Let two to three seconds pass between each depression. The SCD will display **A** when all the error codes have been displayed.
5. After viewing all error codes, exit this function by pressing the Unload Button again. The SCD will display **A** and exit Maintenance Mode.

## Function Code A: Clear Error Code Log

Function Code **A** erases the contents of the error code log.

1. Place the drive in Maintenance Mode. For instructions, see “Entering Maintenance Mode” on page 3-7.
2. Press the Unload Button once per second until **A** appears in the SCD. (If you cycle past the desired code, press the Unload Button once per second until the code reappears.)
3. Press and hold the Unload Button for three or more seconds, then release it to select the function. **A** flashes in the SCD, followed by **A**. The tape drive erases all errors from the error code log and exits Maintenance Mode.

## Function Code C: Insert Cartridge into Tape Drive

This function cannot be selected by itself, but is part of other maintenance functions (such as Run Tape Drive Diagnostics and Create FMR Tape) that require a tape cartridge to be inserted.

## Function Code E: Test Cartridge & Media

Approximate Run Time = 15 minutes per loop

Total Number of Loops = 10

Function Code  $\boxed{E}$  performs tests that determine whether a suspect cartridge and its magnetic tape are acceptable.

Press the Unload Button to stop the diagnostic and exit maintenance mode. Pressing the Unload Button once will abort the test at the end of the current test loop. Pressing the Unload Button twice will abort the test immediately. Wait for the drive to rewind the tape and unload the cartridge.

**Attention:** When you perform this test, data on the suspect tape will be overwritten.

**Note:** If you inserted an invalid tape cartridge (e.g. Gen1 or WORM media), error code  $\boxed{I}$  appears in the SCD. If you inserted a write-protected cartridge, or the media has read-only compatibility (e.g., Gen2 media), error code  $\boxed{P}$  appears in the SCD. In either case, the tape drive unloads the cartridge and exits Maintenance Mode after the cartridge is removed.

1. Place the drive in Maintenance Mode. For instructions, see “Entering Maintenance Mode” on page 3-7.
2. Press the Unload Button once per second until  $\boxed{E}$  appears in the SCD. (If you cycle past the desired code, press the Unload Button once per second until the code reappears.)
3. Press and hold the Unload Button for three or more seconds, then release it to select the function. The SCD changes to a flashing  $\boxed{C}$ .
4. Ensure that the write-protect switch on the suspect cartridge is off, then insert the cartridge (or the tape drive exits maintenance mode). The SCD changes to  $\boxed{E}$ . The tape drive runs the tests.
  - If no error is detected, the diagnostic will loop and begin again. To stop the loop, press the Unload Button for one second and release. When the loop ends,  $\boxed{C}$  temporarily appears in the SCD.
  - If an error is detected, the Status Light flashes amber and the drive posts an error code to the SCD. To determine the error, locate the code in Table 5-3 on page 5-3. To clear the error either turn the power off and then on again, or reboot the drive by pressing and holding the Unload Button for 10 seconds.

## Function Code F: Write Performance Test

Approximate Run Time = 5 minutes per loop

Total Number of Loops = 10

Function Code **F** performs tests to ensure that the drive can read from and write to tape.

Press the Unload Button to stop the diagnostic and exit maintenance mode. Pressing the Unload Button once will abort the test at the end of the current test loop. Pressing the Unload Button twice will abort the test immediately. Wait for the drive to rewind the tape and unload the cartridge.

**Attention:** For this test, insert only a scratch (blank) data cartridge or a cartridge that may be overwritten. During the test, the drive overwrites the data on the cartridge.

**Note:** If you inserted an invalid tape cartridge (e.g. Gen1 or WORM media), error code **7** appears in the SCD. If you inserted a write-protected cartridge, or the media has read-only compatibility (e.g., Gen2 media), error code **F** appears in the SCD. In either case, the tape drive unloads the cartridge and exits Maintenance Mode after the cartridge is removed.

1. Place the drive in Maintenance Mode. For instructions, see “Entering Maintenance Mode” on page 3-7.
2. Press the Unload Button once per second until **F** appears in the SCD. (If you cycle past the desired code, press the Unload Button once per second until the code reappears.)
3. Press and hold the Unload Button for three or more seconds, then release it to select the function. The SCD changes to a flashing **C**.
4. Insert a scratch (blank) data cartridge. The SCD changes to a flashing **F** and the tape drive runs the tests.

**Note:** If you inserted an invalid tape cartridge (e.g. Gen1 or WORM media),

error code **7** appears in the SCD. If you inserted a write-protected cartridge, or the media has read-only compatibility (e.g., Gen2 media),

error code **F** appears in the SCD. In either case, the tape drive unloads the cartridge and exits Maintenance Mode after the cartridge is removed.

- If no error is detected, the diagnostic will loop and begin again. To stop the loop, press the Unload Button for one second and release. When the loop ends, **C** temporarily appears in the SCD.
- If an error is detected, the Status Light flashes amber and the drive posts an error code to the SCD. To determine the error, locate the code in Table 5-3 on page 5-3. To clear the error either turn the power off and then on again, or reboot the drive by pressing and holding the Unload Button for 10 seconds.

## Function Code H: Test Head

Approximate Run Time = 10 minutes per loop

Total Number of Loops = 10

Function Code  $\boxed{H}$  performs tests to ensure that the tape drive's head and tape-carriage mechanics work correctly.

Once you begin this test, the diagnostic begins the loop sequence. Time the first loop by pressing the Unload Button once to stop the diagnostic after the completion of the first loop, then record the time it takes for the test to complete. Compare the recorded time with the "Approximate Run Time" above. If the test runs successfully but the execution time is significantly longer than the "Approximate Run Time", run "Function Code F: Write Performance Test" on page 3-17. If the Write Performance Test fails, replace the media and exit maintenance mode.

Press the Unload Button to stop the diagnostic and exit maintenance mode. Pressing the Unload Button once will abort the test at the end of the current test loop. Pressing the Unload Button twice will abort the test immediately. Wait for the drive to rewind the tape and unload the cartridge.

**Attention:** For this test, insert only a scratch (blank) data cartridge or a cartridge that may be overwritten. During the test, the drive overwrites the data on the cartridge.

**Note:** If you inserted an invalid tape cartridge (e.g. Gen1 or WORM media), error

code  $\boxed{7}$  appears in the SCD. If you inserted a write-protected cartridge, or the media has read-only compatibility (e.g., Gen2 media), error code  $\boxed{P}$  appears in the SCD. In either case, the tape drive unloads the cartridge and exits Maintenance Mode after the cartridge is removed.

1. Place the drive in Maintenance Mode. For instructions, see "Entering Maintenance Mode" on page 3-7.
2. Press the Unload Button once per second until  $\boxed{H}$  appears in the SCD. (If you cycle past the desired code, press the Unload Button once per second until the code reappears.)
3. Press and hold the Unload Button for three or more seconds, then release it to select the function. The SCD changes to a flashing  $\boxed{C}$ .
4. Insert a scratch (blank) data cartridge. The SCD changes to a flashing  $\boxed{H}$ . The tape drive runs the tests.
  - If no error is detected, the diagnostic will loop and begin again. To stop the loop, press the Unload Button for one second and release. When the loop ends,  $\boxed{C}$  temporarily appears in the SCD.
  - If an error is detected, the Status Light flashes amber and the drive posts an error code to the SCD. To determine the error, locate the code in Table 5-3 on page 5-3. To clear the error either turn the power off and then on again, or reboot the drive by pressing and holding the Unload Button for 10 seconds.

## Function Code J: Fast Read/Write Test

Approximate Run Time = 5 minutes per loop



Total Number of Loops = 10





Function Code  performs tests to ensure that the drive can read from and write to tape.

Once you begin this test, the diagnostic begins the loop sequence. Time the first loop by pressing the Unload Button once to stop the diagnostic after the completion of the first loop, then record the time it takes for the test to complete. Compare the recorded time with the "Approximate Run Time" above. If the test runs successfully but the execution time is significantly longer than the "Approximate Run Time", run "Function Code F: Write Performance Test" on page 3-17. If the Write Performance Test fails, replace the media and exit maintenance mode.

Press the Unload Button to stop the diagnostic and exit maintenance mode. Pressing the Unload Button once will abort the test at the end of the current test loop. Pressing the Unload Button twice will abort the test immediately. Wait for the drive to rewind the tape and unload the cartridge.

**Attention:** For this test, insert only a scratch (blank) data cartridge or a cartridge that may be overwritten. During the test, the drive overwrites the data on the cartridge.

**Note:** If you inserted an invalid tape cartridge (e.g. Gen1 or WORM media), error code  appears in the SCD. If you inserted a write-protected cartridge, or the media has read-only compatibility (e.g., Gen2 media), error code  appears in the SCD. In either case, the tape drive unloads the cartridge and exits Maintenance Mode after the cartridge is removed.

1. Place the drive in Maintenance Mode. For instructions, see "Entering Maintenance Mode" on page 3-7.
2. Press the Unload Button once per second until  appears in the SCD. (If you cycle past the desired code, press the Unload Button once per second until the code reappears.)
3. Press and hold the Unload Button for three or more seconds, then release it to select the function. The SCD changes to a flashing .
4. Insert a scratch (blank) data cartridge. The SCD changes to a flashing  and the tape drive runs the tests.
  - If no error is detected, the diagnostic will loop and begin again. To stop the loop, press the Unload Button for one second and release. When the loop ends,  temporarily appears in the SCD.
  - If an error is detected, the Status Light flashes amber and the drive posts an error code to the SCD. To determine the error, locate the code in Table 5-3 on page 5-3. To clear the error either turn the power off and then on again, or reboot the drive by pressing and holding the Unload Button for 10 seconds.

## Function Code L: Load/Unload Test

Approximate Run Time = 15 seconds per loop

Total Number of Loops = 10

Function Code  $\boxed{L}$  tests the drive's ability to load and unload a tape cartridge.

Press the Unload Button to stop the diagnostic and exit maintenance mode. Pressing the Unload Button once will abort the test at the end of the current test loop. Pressing the Unload Button twice will abort the test immediately. Wait for the drive to rewind the tape and unload the cartridge.

**Attention:** Even though no data is written during this test, it is recommended that you use a blank (scratch) cartridge for this test.

1. Place the drive in Maintenance Mode. For instructions, see "Entering Maintenance Mode" on page 3-7.
2. Press the Unload Button once per second until  $\boxed{L}$  appears in the SCD. (If you cycle past the desired code, press the Unload Button once per second until the code reappears.)
3. Press and hold the Unload Button for three or more seconds, then release it to select the function. The SCD changes to a flashing  $\boxed{L}$ .
4. Insert a scratch (blank) data cartridge. The SCD changes to a flashing  $\boxed{L}$  and the tape drive runs the tests.
  - If no error is detected, the diagnostic will loop and begin again. To stop the loop, press the Unload Button for one second and release. When the loop ends,  $\boxed{L}$  temporarily appears in the SCD.
  - If an error is detected, the Status Light flashes amber and the drive posts an error code to the SCD. To determine the error, locate the code in Table 5-3 on page 5-3. To clear the error either turn the power off and then on again, or reboot the drive by pressing and holding the Unload Button for 10 seconds.



## Function Code P: Post Error Reporting Enabled

When Post Error Reporting is enabled, deferred-check conditions are reported to the host and temporary errors are reported in the sense data. Function Code  $\boxed{P}$  will be displayed in Maintenance Mode when the drive has Post Error Reporting enabled.

This selection is normally used as a request from support personnel.

1. Place the drive in Maintenance Mode. For instructions, see "Entering Maintenance Mode" on page 3-7.
2. Press the Unload Button once per second until either  $\boxed{P}$  or  $\boxed{U}$  appears in the SCD.  $\boxed{P}$  or  $\boxed{U}$  will appear in the SCD to indicate the current setting for Post Error Reporting. If you cycle past the desired code, press the Unload Button once per second until the code reappears.









3. Exit Maintenance Mode if you do not want to change the current setting for Post Error Reporting. For instructions, see “Exiting Maintenance Mode” on page 3-7.
4. To disable Post Error Reporting, Press and hold the Unload Button for three seconds while  appears in the SCD. The SCD changes to  after you release the Unload Button.
5. Press the Unload Button once per second to select another Maintenance Mode Function. To exit Maintenance Mode, refer to “Exiting Maintenance Mode” on page 3-7.

## Function Code U: Post Error Reporting Disabled

When Post Error Reporting is disabled, deferred-check conditions are not reported to the host and temporary errors are not reported in the sense data. This is the normal (default) setting for the drive. When the drive has Post Error Reporting

disabled, Function Code  will be displayed in Maintenance Mode. The drive will default to Post Error Reporting disabled after a reboot or power off/on cycle.

1. Place the drive in Maintenance Mode. For instructions, see “Entering Maintenance Mode” on page 3-7.
2. Press the Unload Button once per second until either  or  appears in the SCD.  or  will appear in the SCD to indicate the current setting for Post Error Reporting. If you cycle past the desired code, press the Unload Button once per second until the code reappears.
3. Exit Maintenance Mode if you do not want to change the current setting for Post Error Reporting. For instructions, see “Exiting Maintenance Mode” on page 3-7.
4. To disable Post Error Reporting, Press and hold the Unload Button for three seconds while  appears in the SCD. The SCD changes to  after you release the Unload Button.
5. Press the Unload Button once per second to select another Maintenance Mode Function. To exit Maintenance Mode, refer to “Exiting Maintenance Mode” on page 3-7.

---

## Updating Firmware

**Attention:** When updating firmware, do not power-off the drive until the update is complete, or the firmware may be lost.

It is the customer’s responsibility to ensure that this drive has the latest firmware. Periodically check for updated levels of drive firmware by visiting the web at <http://www.ibm.com/storage/lto>. Update drive firmware using:

- The host interface
- The LDI or RS-422 interface
- The ITDT tool
- A field microcode replacement (FMR) tape cartridge

For instructions on obtaining a new firmware image or FMR tape, visit <http://www.ibm.com/storage/lto>. To update the firmware, refer to the following sections.

## Updating Firmware through the Host Interface

**Attention:** SCSI drives, Fibre Channel drives, and SAS drives require different firmware images.

When updating drive firmware by using the host interface, the procedure varies depending on whether your server uses an IBM tape device driver or a non-IBM tape device driver (such as a driver from Sun, Hewlett-Packard, or Microsoft®).

For instructions about updating firmware from a server that uses an IBM tape device driver, refer to the *IBM Tape Device Drivers Installation and User's Guide*.

To update firmware from a server that uses a non-IBM tape device driver, refer to the documentation for that device driver.

## Updating Firmware through the Library/Drive Interface

The drive includes a firmware update feature that allows a tape library to download firmware to the drive by using the Library/Drive Interface (LDI) while the drive performs normal host operations on logical unit number (LUN) 0 of the SCSI Protocol Interface. The command may be received by the host interface or the LDI (RS-422) interface. For specific instructions about updating the drive firmware in a library, refer to the library documentation and procedures.

**Note:** If a Power-on Reset command is received while a cartridge is loaded in the drive, the drive will respond with a Check Condition. It will not activate the new code level until you cycle power, or until a Power-on Reset command is received and the drive does not contain a cartridge.

## ITDT Firmware Update, Dump Retrieval and Library/Drive Test Tool

ITDT is a tool with multiple functional capability and is a very quick, convenient, and efficient method for both drive and library firmware updates. As a note, both drive and library dump retrievals can be performed by the tool as well.

Below are some of the capabilities of this tool:

- Firmware update capability to all IBM LTO Tape Drive and Tape Library products.
- The tool does not require any special device drivers.
- The tool is available for most major platforms (Windows®, AIX, SUN, Linux, NetWare, AS/400).
- The tool is capable of uploading drive and library dump files.
- The tool's primary function is thoroughly testing a drive. However, if the library is online to the server/host where the tool resides, ITDT will communicate with the drive through the library to load and unload a test cartridge thereby exercising some library functions.
- The tool scans the host bus and will find and display for selection all IBM LTO devices. The tool will not display and allow for selection any non-IBM device.
- Each function has "Help" selection which explains the required syntax as well as a brief explanation of the particular function.
- A Readme text file will be posted with the .exe for a thorough explanation of initial tool download information from the web as well as explanation of tool

capabilities. Refer to the ITDT Readme text file for information on tool usage. You can also refer to the web at <http://www.ibm.com/storage/lto> and look for information about the ITDT site.

- The tool is currently a "command line" tool with a simple entry by keying in the executable name, itdt, from the directory where the tool is located.

The SCD presents a series of random characters during the firmware download

and update. The SCD briefly displays , then becomes blank (not lit) when the firmware download and update is complete and there are no errors. An error code will be displayed if a firmware download or update error has been detected. The Status Light briefly becomes green and then becomes amber during the firmware download and update. The Status Light becomes solid green after the firmware download and update are complete.

## Updating the Firmware with an FMR Tape Cartridge

**Attention:** SCSI drives, Fibre Channel drives, and SAS drives require different firmware images.

### To update the drive's firmware from an FMR tape cartridge:

1. Create an FMR tape (see "Function Code 3: Create FMR Tape" on page 3-10). A single FMR tape can be used to update multiple drives if the drives are the same drive type (e.g. LTO Gen4) and host interface (e.g. SCSI, SAS, fibre channel).
2. Update the drive firmware (see "Function Code 2: Update Drive Firmware from FMR Tape" on page 3-9).

After updating the drive firmware, the FMR tape can be used as a data cartridge by using the "Unmake FMR Tape" function (see "Function Code 8: Unmake FMR Tape" on page 3-14).



---

## Chapter 4. Using Ultrium Media

To ensure that your IBM Ultrium Tape Drive conforms to IBM's specifications for reliability, use only IBM LTO Ultrium tape cartridges. You may use other LTO-certified data cartridges, but they may not meet the standards of reliability that are established by IBM. The IBM LTO Ultrium 800 GB Data Cartridge cannot be interchanged with the media used in other IBM non-LTO Ultrium tape products.

Figure 4-1 shows the IBM LTO Ultrium 800 GB Data Cartridge and its components.

<b>1</b>	LTO cartridge memory	<b>4</b>	Write-protect Switch
<b>2</b>	Cartridge door	<b>5</b>	Label area
<b>3</b>	Leader Pin	<b>6</b>	Insertion guide

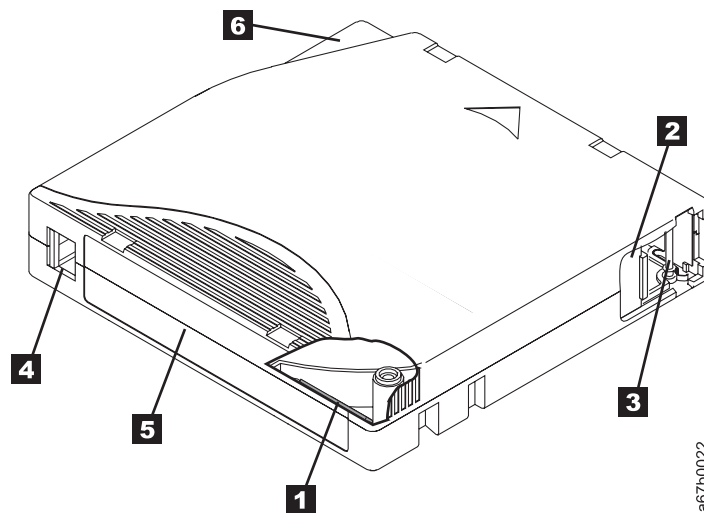

Figure 4-1. The IBM LTO Ultrium 800 GB Data Cartridge

---

### Data Cartridges

The different generations of Ultrium data cartridges can be identified by color:

- The Ultrium 4 Data Cartridge is green
- The Ultrium 3 Data Cartridge is slate blue
- The Ultrium 2 Data Cartridge is purple
- The Ultrium 1 Data Cartridge is black

All generations contain 1/2-inch, dual-coat, metal-particle tape.

You can order tape cartridges with the bar code labels included, or you can order custom labels. To obtain tape cartridges and bar code labels, see "Ordering Media Supplies" on page 4-18.

The native data capacity of Ultrium data cartridges is as follows:

- The Ultrium 4 cartridge has a native data capacity of 800 GB (1600 GB at 2:1 compression)
- The Ultrium 3 cartridge has a native data capacity of 400 GB (800 GB at 2:1 compression).
- The Ultrium 2 cartridge has a native data capacity of 200 GB (400 GB at 2:1 compression).
- The Ultrium 1 cartridge has a native data capacity of 100 GB (200 GB at 2:1 compression).

When processing tape in the cartridges, Ultrium Tape Drives use a linear, serpentine recording format.

- The Ultrium 4 drive reads and writes data on 896 tracks, sixteen tracks at a time.
- The Ultrium 3 drive reads and writes data on 704 tracks, sixteen tracks at a time.
- The Ultrium 2 drive reads and writes data on 512 tracks, eight tracks at a time.
- The Ultrium 1 drive reads and writes data on 384 tracks, eight tracks at a time.

The first set of tracks (sixteen for Ultrium 4 and 3; eight for Ultrium 2 and 1) is written from near the beginning of the tape to near the end of the tape. The head then repositions to the next set of tracks for the return pass. This process continues until all tracks are written and the cartridge is full, or until all data is written.

The cartridge door **2** protects the tape from contamination when the cartridge is out of the drive. Behind the door, the tape is attached to a leader pin **3**. When the cartridge is inserted into the drive, a threading mechanism pulls the pin (and tape) out of the cartridge, across the drive head, and onto a non-removable take-up reel. The head can then read or write data from or to the tape.

The write-protect switch **4** prevents data from being written to the tape cartridge. For more information, see “Write-Protect Switch” on page 4-6.

The label area **5** provides a location to place a label. For more information, see “Bar Code Label” on page 4-4.

The insertion guide **6** is a large, notched area that prevents the cartridge from being inserted incorrectly.

Generation 3 and 4 of the LTO Ultrium Data Cartridge have a nominal cartridge life of 20,000 (20k) load and unload cycles. Generation 2 has a nominal cartridge life of 10,000 (10k) load and unload cycles. Generation 1 of the LTO Ultrium Data Cartridge has a nominal cartridge life of 5000 (5k) load and unload cycles.

## Cartridge Compatibility

Table 4-1. Ultrium data cartridge compatibility with Ultrium tape drive

IBM Ultrium Tape Drive	IBM LTO Ultrium Data Cartridges			
	800 GB (Ultrium 4)	400 GB (Ultrium 3)	200GB (Ultrium 2)	100GB (Ultrium 1)
Ultrium 4	Read/Write	Read/Write	Read only	
Ultrium 3		Read/Write	Read/Write	Read only
Ultrium 2			Read/Write	Read/Write
Ultrium 1				Read/Write

## Capacity Scaling

To control the capacity of the cartridge (for example, to obtain a faster seek time) issue the SCSI command SET CAPACITY. For information about this command, refer to the *IBM Ultrium Tape Drive SCSI Reference*.

---

## WORM (Write Once, Read Many)

Certain records retention and data security applications require a Write Once, Read Many (WORM) method for storing data on tape. The IBM LTO Ultrium generation 4 drive enables WORM support when a WORM tape cartridge is loaded into the drive.

### WORM Media

Because standard read/write media are incompatible with the WORM feature, a specially formatted WORM tape cartridge (see Figure 4-2) is required. Each WORM cartridge has a unique, worldwide cartridge identifier (WWCID), which comprises the unique CM chip serial number and the unique tape media serial number. See “Ordering Media Supplies” on page 4-18 for information on how to choose and purchase the appropriate WORM tape cartridges for your library.

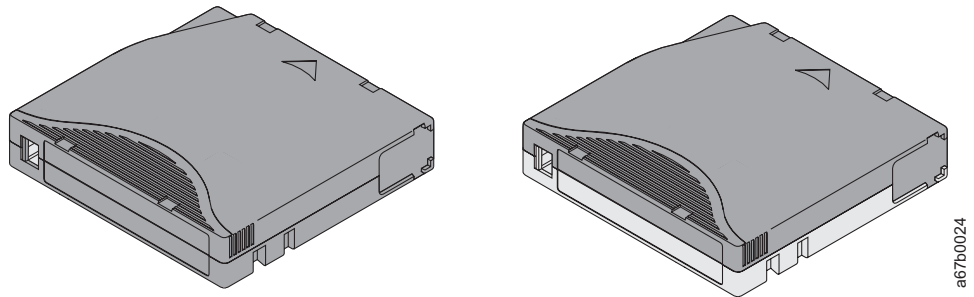

Figure 4-2. Ultrium WORM Tape Cartridge

### Data Security on WORM Media

Certain built-in security measures help ensure that the data written on a WORM cartridge does not become compromised, for example:

- The format of an IBM Ultrium 4 800 GB or IBM Ultrium 3 400 GB WORM Tape Cartridge is unlike that of standard read/write media. This unique format prevents a drive that lacks WORM-capable firmware from writing on a WORM tape cartridge.
- When the drive senses a WORM cartridge, the firmware prohibits the changing or altering of user data already written on the tape. The firmware keeps track of the last appendable point on the tape.

### WORM Media Errors

The following conditions cause WORM media errors to occur:

- Information in the servo manufacturer's word (SMW) on the tape must match information from the cartridge memory (CM) module in the cartridge. If it does not match, a media Error Code 7 will post on the drive's single-character display (SCD).

- Inserting a WORM tape cartridge into a drive that is not compatible with WORM causes the cartridge to be treated as an unsupported medium. The drive will report a media Error Code 7. Upgrading the drive firmware to the correct code level will resolve the problem.

## Requirements for WORM Capability

To add WORM capability to your IBM LTO Ultrium generation 4 drive(s), you need to use either IBM Ultrium 4 800 GB WORM tape cartridges or IBM Ultrium 3 400 GB WORM tape cartridges (see “Ordering Media Supplies” on page 4-18).

---

## Cleaning Cartridge

With each drive, a specially labeled IBM LTO Ultrium Cleaning Cartridge is supplied to clean the drive head. The drive itself determines when a head needs to be cleaned. It alerts you by displaying  on the Single-character Display. To clean the head, insert the cleaning cartridge into the tape load compartment (see Figure 3-1 on page 3-4). The drive performs the cleaning automatically. When the cleaning is finished, the drive ejects the cartridge.

**Note:** The drive will automatically eject an expired cleaning cartridge.

To remove a cleaning cartridge, see “Removing a Tape Cartridge” on page 3-5.

The IBM Cleaning Cartridges are valid for 50 uses. The cartridge’s LTO-CM chip tracks the number of times that the cartridge is used.

---

## Cartridge Memory Chip (LTO-CM)

All generations of the IBM LTO Ultrium Data Cartridges include a Linear Tape-Open Cartridge Memory (LTO-CM) chip ( **1** in Figure 4-1 on page 4-1), that contains information about the cartridge and the tape (such as the name of the manufacturer that created the tape), as well as statistical information about the cartridge’s use. The LTO-CM enhances the efficiency of the cartridge. For example, the LTO-CM stores the end-of-data location which, when the next time this cartridge is inserted and the Write command is issued, enables the drive to quickly locate the recording area and begin recording. The LTO-CM also aids in determining the reliability of the cartridge by storing data about its age, how many times it has been loaded, and how many errors it has accumulated. Whenever a tape cartridge is unloaded, the tape drive writes any pertinent information to the cartridge memory.

The storage capacity of the LTO Generation 4 LTO-CM is 8160 bytes. LTO Generations 1, 2, and 3 have an LTO-CM capacity of 4096 bytes.

---

## Bar Code Label

A bar code label contains:

- A volume serial number (VOLSER) that is human-readable
- A bar code that the library can read

**Note:** The IBM LTO Ultrium 4 Tape Drive does not require bar code labels, but you may choose to use labels for tape cartridge identification purposes.



When read by a library's bar code reader, the bar code identifies the cartridge's VOLSER to the library. The bar code also tells the library whether the cartridge is a data cartridge or cleaning cartridge. In addition, the bar code includes the two-character media-type identifier LX, where x equals 1, 2, 3, or 4. L identifies the cartridge as an LTO cartridge and the number represents the generation of cartridge for that cartridge type. Figure 4-3 shows a sample bar code label for the LTO Ultrium Tape Cartridge.

Tape cartridges can be ordered with the labels included or with custom labels. To order tape cartridges and bar code labels, see "Ordering Media Supplies" on page 4-18. The bar code for usage in IBM tape libraries must meet predefined specifications. They include (but are not limited to):

- Eight uppercase alphanumeric characters, where the last two characters must be L4, L3, L2, or L1
- Label and printing to be non-glossy
- Nominal narrow line or space width of 0.423 mm (0.017 in.)
- Wide to narrow ratio of 2.75:1
- Minimum bar length of 11.1 mm (0.44 in.)

To determine the complete specifications of the bar code and the bar code label, visit the web at <http://www.ibm.com/storage/lto> (select **LTO Support**), or contact your IBM Sales Representative.

When attaching a bar code label to a tape cartridge, place the label only in the recessed label area (see **5** in Figure 4-1 on page 4-1). A label that extends outside of the recessed area can cause loading problems in the drive.

**Attention:** Do not place any type of mark on the white space at either end of the bar code. A mark in this area may prevent the library from reading the label.

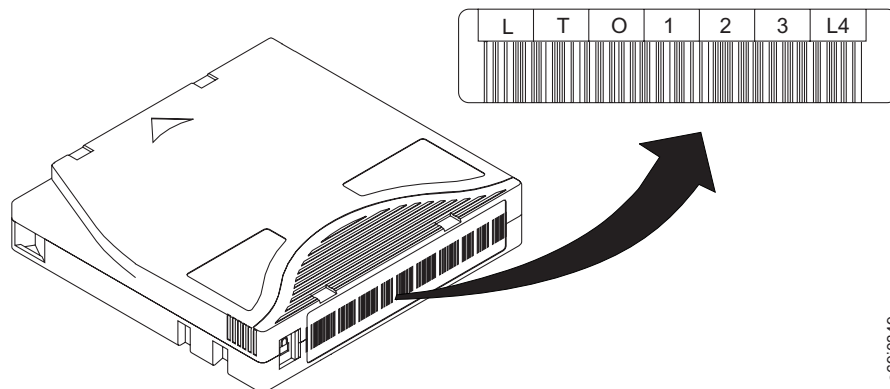

Figure 4-3. Sample bar code label on the LTO Ultrium 4 Tape Cartridge. The volume serial number (LTO123) and bar code are printed on the label.

## Guidelines for Using Bar Code Labels

Apply the following guidelines whenever using bar code labels:

- Use only IBM-approved bar code labels on cartridges to be used in an IBM tape library.
- Do not reuse a label or reapply a used label over an existing label.
- Before you apply a new label, remove the old label by slowly pulling it at a right angle to the cartridge case.

- Use peel-clean labels that do not leave a residue after being removed. If there is glue residue on the cartridge, remove it by gently rubbing it with your finger. Do not use a sharp object, water, or a chemical to clean the label area.
- Examine the label before applying it to the cartridge. Do not use the label if it has voids or smears in the printed characters or bar code (a library's inventory operation will take much longer if the bar code label is not readable).
- Remove the label from the label sheet carefully. Do not stretch the label or cause the edges to curl.
- Position the label within the recessed label area (see **5** in Figure 4-1 on page 4-1).
- With light finger pressure, smooth the label so that no wrinkles or bubbles exist on its surface.
- Verify that the label is smooth and parallel, and has no roll-up or roll-over. The label must be flat to within 0.5 mm (0.02 in.) over the length of the label and have no folds, missing pieces, or smudges.
- Do not place other machine-readable labels on other surfaces of the cartridge. They may interfere with the ability of the drive to load the cartridge.

---

## Write-Protect Switch

The position of the write-protect switch on the tape cartridge (see **1** in Figure 4-4) determines whether you can write to the tape. If the switch is set to the:

- The locked position  (solid red), data cannot be written to the tape.
- The unlocked position (black void), data can be written to the tape.

If possible, use your server's application software to write-protect your cartridges (rather than manually setting the write-protect switch). This allows the server's software to identify a cartridge that no longer contains current data and is eligible to become a scratch (blank) data cartridge. Do not write-protect scratch (blank) cartridges; the tape drive will not be able to write new data to them.

If you must manually set the write-protect switch, slide it left or right to the desired position.

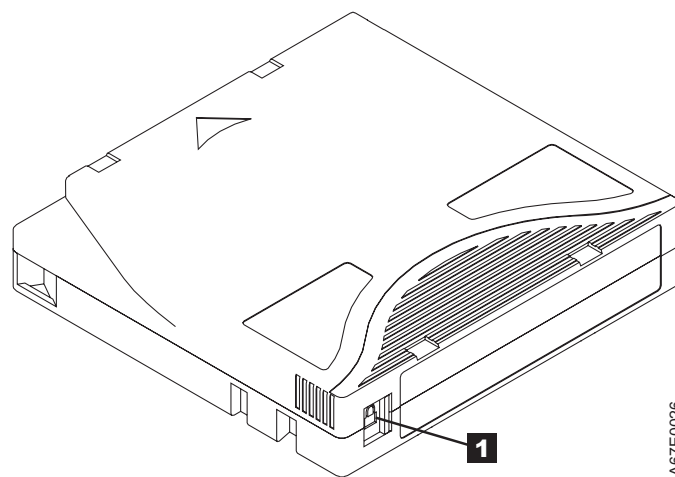

Figure 4-4. Setting the write-protect switch

---

## Handling the Cartridges

**Attention:** Do not insert a damaged tape cartridge into the drive. A damaged cartridge can interfere with the reliability of a drive and may void the warranties of the drive and the cartridge. Before inserting a tape cartridge, inspect the cartridge case, cartridge door, and write-protect switch for breaks.

Incorrect handling or an incorrect environment can damage cartridges or their magnetic tape. To avoid damage to your tape cartridges and to ensure the continued high reliability of your IBM LTO Ultrium Tape Drives, use the following guidelines:

### Provide Training

- Post procedures that describe proper media handling in places where people gather.
- Ensure that anyone who handles tape has been properly trained in handling and shipping procedures. This includes operators, users, programmers, archival services, and shipping personnel.
- Ensure that any service or contract personnel who perform archiving are properly trained in media-handling procedures.
- Include media-handling procedures as part of any services contract.
- Define and make personnel aware of data recovery procedures.

### Ensure Proper Packaging

- When shipping a cartridge, use the original or better packaging.
- Always ship or store a cartridge in a jewel case.
- Use only a recommended shipping container that securely holds the cartridge in its jewel case during transportation. Ultrium Turtlecases (by Perm-A-Store) have been tested and found to be satisfactory (see Figure 4-5). They are available at <http://www.turtlecase.com>.



Figure 4-5. Tape cartridges in a Turtlecase

- Never ship a cartridge in a commercial shipping envelope. Always place it in a box or package.
- If you ship the cartridge in a cardboard box or a box of a sturdy material, ensure the following:
  - Place the cartridge in polyethylene plastic wrap or bags to protect it from dust, moisture, and other contaminants.
  - Pack the cartridge snugly; do not allow it to move around.
  - Double-box the cartridge (place it inside a box, then place that box inside the shipping box) and add padding between the two boxes (see Figure 4-6).



Figure 4-6. Double-boxing tape cartridges for shipping

## Provide Proper Acclimation and Environmental Conditions

- Before using a cartridge, let it acclimate to the normal operating environment for 24 hours. There should be no visible condensation on the cartridge. If condensation is visible on the cartridge, wait an additional hour.
- Ensure that all surfaces of a cartridge are dry before inserting it.
- Do not expose the cartridge to moisture or direct sunlight.
- Do not expose recorded or blank cartridges to stray magnetic fields of greater than 100 oersteds (for example, terminals, motors, video equipment, X-ray equipment, or fields that exist near high-current cables or power supplies). Such exposure can cause the loss of recorded data or make the blank cartridge unusable.
- Maintain the conditions that are described in “Environmental Specifications” on page 1-12.

## Perform a Thorough Inspection

After purchasing a cartridge and before using it, perform the following steps:

- Inspect the cartridge’s packaging to determine potential rough handling.
- When inspecting a cartridge, open only the cartridge door. Do not open any other part of the cartridge case. The upper and lower parts of the case are held together with screws; separating them destroys the usefulness of the cartridge.
- Inspect the cartridge for damage before using or storing it.

- Inspect the rear of the cartridge (the part that loads first into the tape load compartment) and ensure that there are no gaps in the seam of the cartridge case (see **1** in Figure 4-7 and **4** in Figure 4-9 on page 4-11). If there are gaps in the seam (see Figure 4-7), the leader pin may be dislodged. Go to “Repositioning or Reattaching a Leader Pin” on page 4-10.

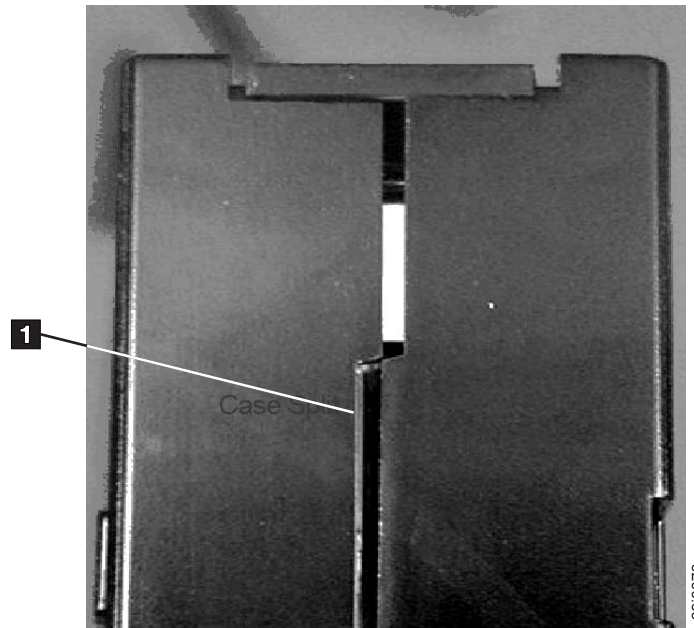

Figure 4-7. Checking for gaps in the seams of a cartridge

- Check that the leader pin is properly seated (see **2** in Figure 4-8 on page 4-11).
- If you suspect that the cartridge has been mishandled but it appears usable, copy any data onto a good cartridge immediately for possible data recovery. Discard the mishandled cartridge.
- Review handling and shipping procedures.

## Handle the Cartridge Carefully

- Do not drop the cartridge. If the cartridge drops, slide the cartridge door back and ensure that the leader pin is properly seated in the pin-retaining spring clips (see **2** in Figure 4-8 on page 4-11). If the leader pin has become dislodged, go to “Repositioning or Reattaching a Leader Pin” on page 4-10.
- Do not handle tape that is outside the cartridge. Handling the tape can damage the tape’s surface or edges, which may interfere with read or write reliability. Pulling on tape that is outside the cartridge can damage the tape and the brake mechanism in the cartridge.
- Do not stack more than six cartridges.
- Do not degauss a cartridge that you intend to reuse. Degaussing makes the tape unusable.

## Examples of Cartridge Problems

### Example: Split Cartridge Case (see Figure 4-7)

The cartridge’s case is damaged. There is a high possibility of media damage and potential loss. Perform the following steps:

1. Look for cartridge mishandling.
2. Use the IBM Leader Pin Reattachment Kit (part number 08L9129) to correctly seat the pin (see “Repositioning or Reattaching a Leader Pin”). Then, immediately use data recovery procedures to minimize chances of data loss.
3. Review media-handling procedures.

**Example: Improper Placement of Leader Pin (see Figure 4-8 on page 4-11)**

The leader pin is misaligned. Perform the following steps:

1. Look for cartridge damage.
2. Use the IBM Leader Pin Reattachment Kit (part number 08L9129) to correctly seat the pin (see “Repositioning or Reattaching a Leader Pin”). Then, immediately use data recovery procedures to minimize chances of data loss.

---

## Repositioning or Reattaching a Leader Pin

**Attention:** Use a repaired tape cartridge only to recover data and move it to another cartridge. Continued use of a repaired cartridge may void the warranties of the drive and the cartridge.

If the leader pin in your cartridge becomes dislodged from its pin-retaining spring clips or detaches from the tape, you must use the IBM Leader Pin Reattachment Kit (part number 08L9129) to reposition or reattach it. (Do not reattach the pin if you must remove more than seven meters (23 feet) of leader tape.) The sections that follow describe each procedure.

**Attention:** Use a repaired tape cartridge only to recover data and move it to another cartridge. Continued use of a repaired cartridge may void the warranties of the drive and the cartridge.

### Repositioning a Leader Pin

A leader pin that is improperly seated inside a cartridge can interfere with the operation of the drive. Figure 4-8 on page 4-11 shows a leader pin in the incorrect **1** and correct **2** positions.

To place the leader pin in its proper position, you will need the following tools:

- Plastic or blunt-end tweezers
- Cartridge manual rewind tool (from Leader Pin Reattachment Kit, part number 08L9129)

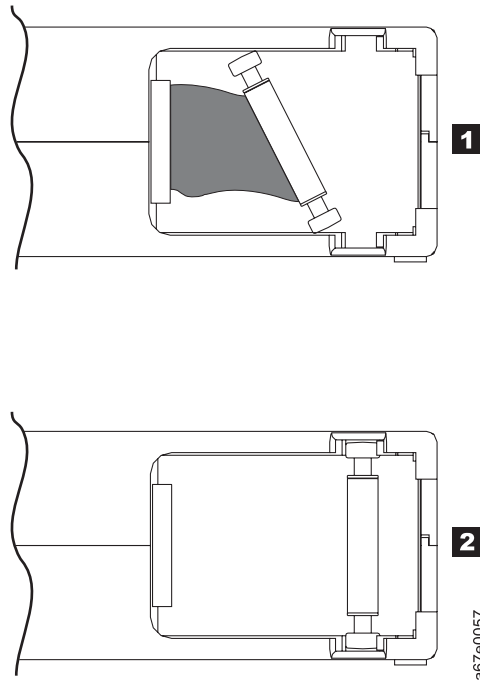

Figure 4-8. Leader pin in the incorrect and correct positions. The cartridge door is open and the leader pin is visible inside the cartridge.

To reposition the leader pin, perform the following steps.

1. Slide open the cartridge door ( **1** in Figure 4-9) and locate the leader pin ( **2** (you may need to shake the cartridge gently to roll the pin toward the door).
2. With plastic or blunt-end tweezers, grasp the leader pin and position it in the pin-retaining spring clips ( **3** ).
3. Press the leader pin gently into the clips until it snaps into place and is firmly seated.
4. Close the cartridge door.

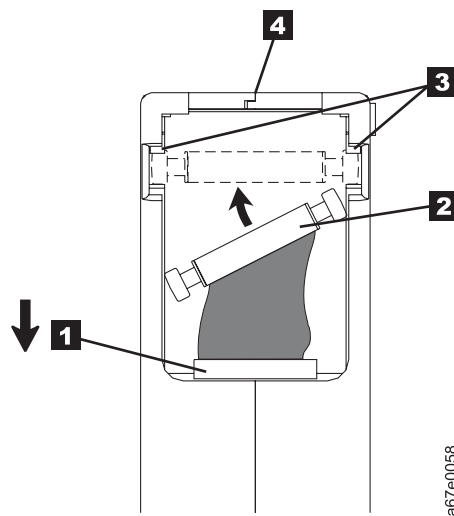

Figure 4-9. Placing the dislodged leader pin into the correct position. The cartridge door is open to show the leader pin.



5. To rewind the tape, insert the cartridge manual rewind tool (**1** in Figure 4-10) into the cartridge's hub (**2**) and turn it clockwise until the tape becomes taut.

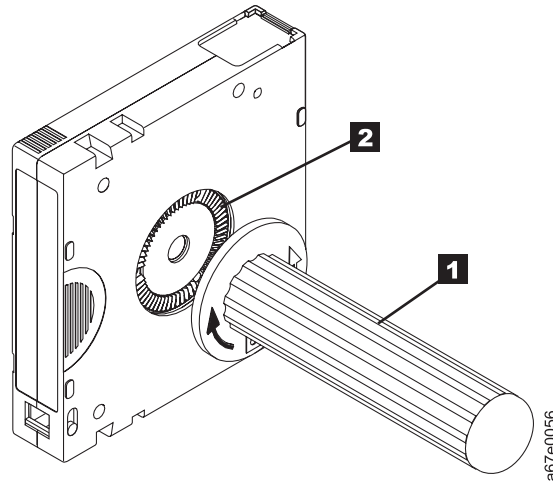

Figure 4-10. Rewinding the tape into the cartridge

6. Remove the rewind tool by pulling it away from the cartridge.
7. If you suspect that the cartridge has been mishandled but it appears useable, copy any data onto a good cartridge immediately for possible data recovery. Discard the mishandled cartridge.

## Reattaching a Leader Pin

The first meter of tape in a cartridge is leader tape. Once the leader tape has been removed there is a possibility of tape breakage. After reattaching the leader pin, transfer data from the defective tape cartridge. **Do not reuse the defective tape cartridge.**

The Leader Pin Reattachment Kit contains three parts:

- **Leader pin attach tool** (see **1** in Figure 4-11 on page 4-13). A plastic brace that holds the cartridge door open.
- **Cartridge manual rewind tool** (see **2** in Figure 4-11 on page 4-13). A device that fits into the cartridge's hub and lets you wind the tape into and out of the cartridge.
- **Pin supplies** (see **3** in Figure 4-11 on page 4-13). Leader pins and C-clips.



**Attention:**

- Use only the IBM Leader Pin Reattachment Kit to reattach the leader pin to the tape. Other methods of reattaching the pin will damage the tape, the drive, or both.
- Use this procedure on your tape cartridge only when the leader pin detaches from the magnetic tape and you must copy the cartridge's data onto another cartridge. Destroy the damaged cartridge after you copy the data. This procedure may affect the performance of the leader pin during threading and unloading operations.
- Touch only the end of the tape. Touching the tape in an area other than the end can damage the tape's surface or edges, which may interfere with read or write reliability.

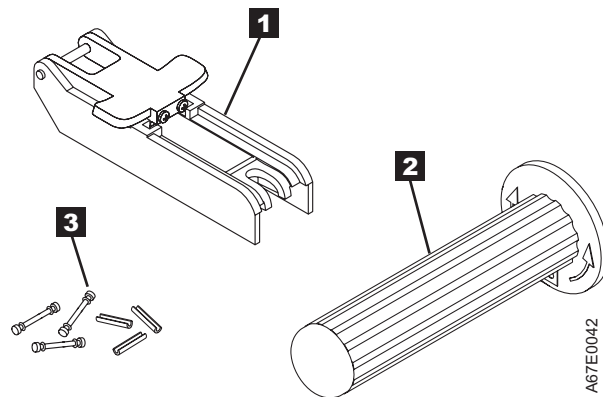
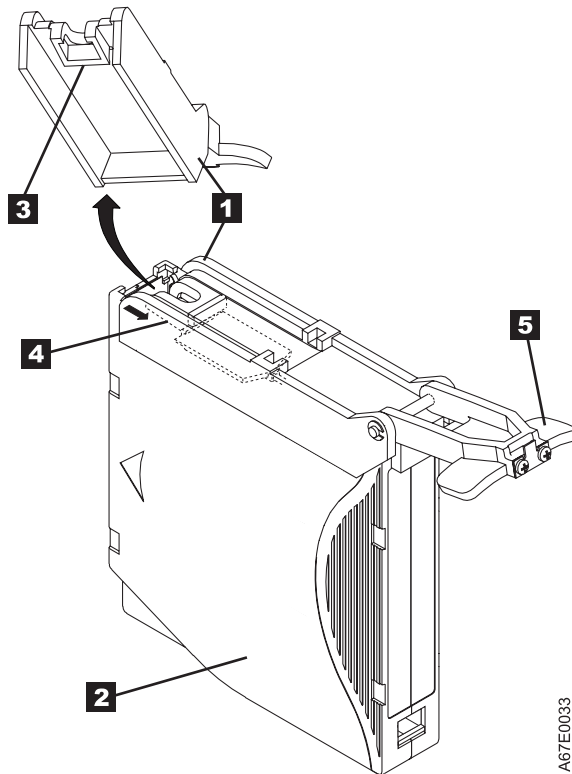

Figure 4-11. Leader Pin Reattachment Kit

The following procedure describes how to reattach a leader pin.

To reattach a leader pin by using the IBM Leader Pin Reattachment Kit:

1. Attach the leader pin attach tool ( **1** in Figure 4-12 on page 4-14) to the cartridge **2** so that the tool's hook **3** latches into the cartridge's door **4**. Pull the tool back to hold the door open, then slide the tool onto the cartridge. Open the tool's pivot arm **5**.



A67E0033

Figure 4-12. Attaching the leader pin attach tool to the cartridge. To hold the cartridge door open, hook the tool into the door and pull the tool back.

2. To find the end of the tape inside the cartridge, attach the cartridge manual rewind tool (**1** in Figure 4-13 on page 4-15) to the cartridge's hub **2** by fitting the tool's teeth between the teeth of the hub. Turn the tool clockwise until you see the end of the tape inside the cartridge. Then, slowly turn the rewind tool counterclockwise to bring the tape edge toward the cartridge door **3**.
3. Continue to turn the rewind tool counterclockwise until approximately 13 cm (5 in.) of tape hangs from the cartridge door. If necessary, grasp the tape and pull gently to unwind it from the cartridge.
4. Remove the rewind tool by pulling it away from the cartridge. Set the tool and the cartridge aside.

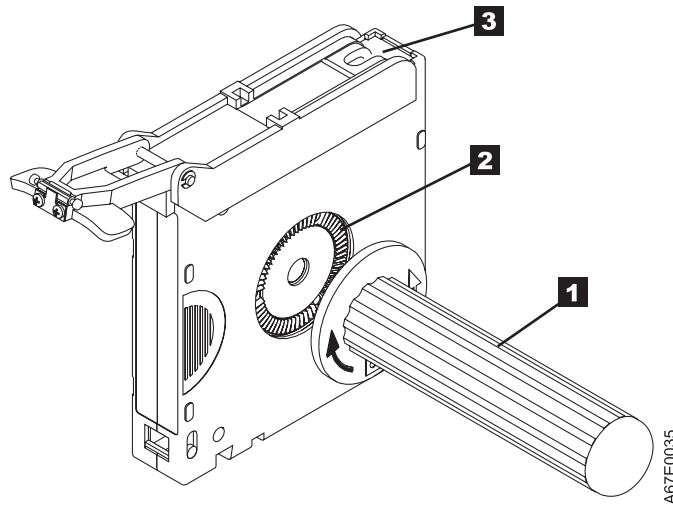

Figure 4-13. Winding the tape out of the cartridge. Turn the cartridge manual rewind tool clockwise to see the end of the tape, then turn it counterclockwise to bring the tape to the cartridge door.

5. On the leader pin ( **1** in Figure 4-14), locate the open side of the C-clip ( **2** ). The C-clip is a small black part that secures the tape ( **3** ) to the pin.
6. Remove the C-clip from the leader pin by using your fingers to push the clip away from the pin. Set the pin aside and discard the clip.

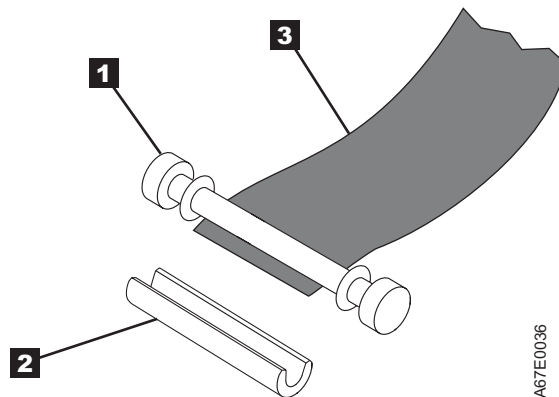

Figure 4-14. Removing the C-clip from the leader pin. Use your fingers to push the C-clip from the leader pin.

7. Position the tape in the alignment groove of the leader pin attach tool (see **1** in Figure 4-15 on page 4-16).
  8. Place a new C-clip into the retention groove ( **2** (Figure 4-15 on page 4-16) on the leader pin attachment tool and make sure that the clip's open side faces up.
  9. Place the leader pin (from step 6) into the cavity ( **3** (Figure 4-15 on page 4-16) of the leader pin attach tool.
- Attention:** To prevent the leader pin from rolling into the cartridge, in the following step use care when folding the tape over the pin.
10. Fold the tape over the leader pin and hold it with your fingers (see Figure 4-15 on page 4-16).

**Note:** Use care to ensure that the tape is centered over the leader pin. Failure to properly center the tape on the pin will cause the repaired cartridge to fail. When the tape is properly centered, a 0.25-mm (0.01-in.) gap

exists on both sides of the pin.

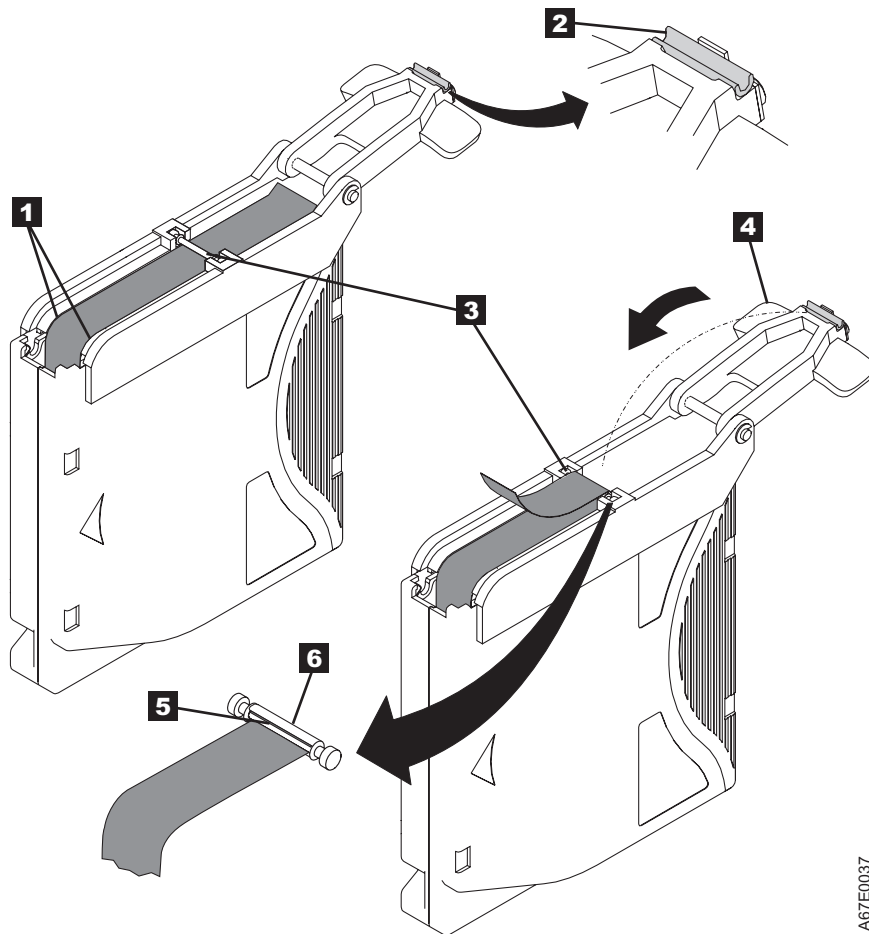

Figure 4-15. Attaching the leader pin to the tape

11. Close the pivot arm **4** of the leader pin attach tool by swinging it over the leader pin so that the C-clip snaps onto the pin and the tape.
12. Swing the pivot arm open and trim the excess tape **5** so that it is flush with the reattached leader pin **6**.
13. Use your fingers to remove the leader pin from the cavity **3** in the leader pin attach tool.
14. Use the cartridge manual rewind tool to wind the tape back into the cartridge (wind the tape clockwise). Ensure that the leader pin is latched by the pin-retaining spring clips on each end of the leader pin.
15. Remove the rewind tool.
16. Remove the leader pin attach tool by lifting its end up and away from the cartridge.

---

## Environmental and Shipping Specifications for Tape Cartridges

Before you use a tape cartridge, acclimate it to the operating environment for 24 hours or the time necessary to prevent condensation in the drive (the time will vary, depending on the environmental extremes to which the cartridge was exposed).

The best storage container for the cartridges (until they are opened) is the original shipping container. The plastic wrapping prevents dirt from accumulating on the cartridges and partially protects them from humidity changes.

When you ship a cartridge, place it in its jewel case or in a sealed, moisture-proof bag to protect it from moisture, contaminants, and physical damage. Ship the cartridge in a shipping container that has enough packing material to cushion the cartridge and prevent it from moving within the container.

Table 4-2 gives the environment for operating, storing, and shipping LTO Ultrium Tape Cartridges.

Table 4-2. Environment for operating, storing, and shipping the LTO Ultrium Tape Cartridge

Environmental Factor	Environmental Specifications			
	Operating	Operational Storage <sup>1</sup>	Archival Storage <sup>2</sup>	Shipping
Temperature	10 to 45°C(50 to 113°F)	16 to 32°C(61 to 90°F)	16 to 25°C(61 to 77°F)	-23 to 49°C(-9 to 120°F)
Relative humidity (non-condensing)	10 to 80%	20 to 80%	20 to 50%	5 to 80%
Maximum wet bulb temperature	26°C(79°F)	26°C(79°F)	26°C(79°F)	26°C(79°F)
<b>Note:</b>				
1. The short term or operational storage environment is for storage durations of up to six months.				
2. The long term or archival storage environment is for durations of six months up to ten years.				
3. Local tape temperature in excess of 52 deg C may cause permanent tape damage.				

## Disposing of Tape Cartridges

Under the current rules of the U.S. Environmental Protection Agency (EPA), regulation 40CFR261, the LTO Ultrium Tape Cartridge is classified as non-hazardous waste. As such, it may be disposed of in the same way as normal office trash. These regulations are amended from time to time, and you should review them at the time of disposal.

If your local, state, country (non-U.S.A.), or regional regulations are more restrictive than EPA 40CFR261, you must review them before you dispose of a cartridge. Contact your account representative for information about the materials that are in the cartridge.

If a tape cartridge must be disposed of in a secure manner, you can erase the data on the cartridge by using a high-energy ac degausser (use a minimum of 4000 oersted peak field over the entire space that the cartridge occupies). The tape should make two passes through the field at 90 degree orientation change for each pass to achieve complete erasure. Some commercial degaussers have two magnetic field regions offset 90 degrees from each other to accomplish complete erasure in one pass for higher throughput. Degaussing makes the cartridge unusable.

If you burn the cartridge and tape, ensure that the incineration complies with all applicable regulations.

## Ordering Media Supplies

Table 4-3 lists the cartridges and media supplies that you can order for the drive.

Table 4-3. Media supplies

Supply Item	Methods of Ordering
<b>20-PACK IBM LTO Ultrium 800 GB Data Cartridge (with attached labels)</b>	<p>Order the cartridge from your IBM Sales Representative or any authorized IBM Business Partner by specifying Machine Type 3589 Model 010. Specify the VOLSER characters that you want.</p> <p>Order as part number 95P4443 (color label) or 95P4445 (black and white label) through an IBM-authorized distributor. Specify the VOLSER characters that you want.</p>
<b>20-PACK IBM LTO Ultrium 800 GB Data Cartridge (without attached labels)</b>	<p>Order the cartridge from your IBM Sales Representative or any authorized IBM Business Partner by specifying Machine Type 3589 Model 011.</p> <p>Order as part number 95P4447 through an IBM-authorized distributor.</p>
<b>5-PACK IBM LTO Ultrium 800 GB Data Cartridge</b>	<p>Order as part number 95P4278 through an IBM-authorized distributor.</p>
<b>20-PACK IBM Ultrium 4 800 GB WORM Tape Cartridge (with attached labels)</b>	<p>Order the cartridge from your IBM Sales Representative or any authorized IBM Business Partner by specifying Machine Type 3589 Model 032.</p> <p>Order as part number 95P4457 (color label) or 95P4459 (black and white label) through an IBM-authorized distributor. Specify the VOLSER characters that you want.</p>
<b>20-PACK IBM Ultrium 4 800 GB WORM Tape Cartridge (without attached labels)</b>	<p>Order the cartridge from your IBM Sales Representative or any authorized IBM Business Partner by specifying Machine Type 3589 Model 033.</p> <p>Order as part number 95P4461 through an IBM-authorized distributor. Specify the VOLSER characters that you want.</p>
<b>IBM TotalStorage LTO Ultrium 400 GB Data Cartridge</b> Bar code labels are pre-applied to cartridges.	<p>Order the cartridge from your IBM Sales Representative or any authorized IBM Business Partner by specifying Machine Type 3589 Model 008. Specify the VOLSER characters that you want.</p> <p>Order as part number 96P1470 (color label) or 96P1471 (black and white label) through an IBM-authorized distributor. Specify the VOLSER characters that you want.</p>
<b>IBM LTO Ultrium 400 GB Data Cartridge</b> Order VOLSER labels separately.	<p>Order the cartridge from your IBM Sales Representative or any authorized IBM Business Partner by specifying Machine Type 3589 Model 009.</p> <p>Order as part number 24R1922 through an IBM-authorized distributor. Specify the VOLSER characters that you want.</p>
<b>5-PACK IBM LTO Ultrium 400 GB Data Cartridge</b>	<p>Order as part number 95P2020 through an IBM-authorized distributor. Specify the VOLSER characters that you want.</p>

Table 4-3. Media supplies (continued)

Supply Item	Methods of Ordering
<p><b>IBM Ultrium 3 400 GB WORM Tape Cartridge (with attached labels)</b></p> <p>IBM TotalStorage 3589 Model 028/Feature Code 2820 is a 20-pack of WORM cartridges labeled with starting volume serial information and, optionally, packed in individual jewel cases. Attached labels have been preprinted with a Bar Code that ends with LT, where L stands for LTO, and T identifies the cartridge as a WORM cartridge. This media can be used with LTO 3 drives (read/write).</p>	<p>Order by Machine Type/Model and Feature Code through an IBM-authorized distributor.</p>
<p><b>IBM Ultrium 3 400 GB WORM Tape Cartridge (without attached labels)</b></p> <p>IBM TotalStorage 3589 Model 029/Feature Code 2920 is a 20-pack of WORM cartridges packed in individual jewel cases with unattached blank labels. This media can be used with LTO 3 drives (read/write).</p>	<p>Order by Machine Type/Model and Feature Code through an IBM-authorized distributor.</p>
<p><b>IBM LTO Ultrium 200 GB Data Cartridge</b></p> <p>Bar code labels are pre-applied to cartridges.</p>	<p>Order the cartridge from your IBM Sales Representative or any authorized IBM Business Partner by specifying Machine Type 3589 Model 006. Specify VOLSER characters you want.</p>
<p><b>IBM LTO Ultrium 200 GB Data Cartridge</b></p> <p>Order VOLSER labels separately (see "Ordering Bar Code Labels").</p>	<p>Order the cartridge from your IBM Sales Representative or any authorized IBM Business Partner by specifying Machine Type 3589 Model 007.</p>
<p><b>IBM LTO Ultrium 100 GB Data Cartridge</b></p> <p>Order VOLSER labels separately (see "Ordering Bar Code Labels").</p>	<p>Order as part number 08L9120 through an IBM-authorized distributor.</p>
<p><b>IBM LTO Ultrium Cleaning Cartridge (universal cleaning cartridge for use with all Ultrium drives)</b></p> <p>VOLSER labels are included.</p>	<p>Order as part number 35L2086 through an IBM-authorized distributor. IBM LTO cleaning cartridges with part number 08L9124 are also supported.</p>
<p><b>Leader Pin Reattachment Kit</b></p>	<p>Order as part number 08L9129 through an IBM-authorized distributor.</p>
<p><b>Manual Rewind Tool</b></p>	<p>Order as part number 08L9130 through an IBM-authorized distributor.</p>

To find the closest IBM-authorized distributor, visit the web at <http://www.ibm.com/storage/media> or call 1-888-IBM-MEDIA.

## Ordering Bar Code Labels

The IBM LTO Ultrium 4 Tape Drive does not require cartridge bar code labels. However, if you use your data cartridges or cleaning cartridges in an IBM tape library product, you may need cartridge bar code labels if your tape library product requires them. You can order these labels separately from the IBM Data Cartridges and Cleaning Cartridges.

You can order bar code labels directly from the authorized label suppliers in Table 4-4.

Table 4-4. Authorized suppliers of custom bar code labels

In America	In Europe and Asia
<p>EDP/Colorflex 2550 W. Midway Blvd. Broomfield, CO 80020 U. S. A. Telephone: 800-522-3528 <a href="http://www.colorflex.com/">http://www.colorflex.com/</a></p>	<p>EDP Europe, Ltd. 43 Redhills Road South Woodham Ferrers Chelmsford, Essex CM3 5UL U. K. Telephone: 44 (0) 1245-322380 <a href="http://www.edpeurope.com/media_labelling.htm">http://www.edpeurope.com/media_labelling.htm</a></p>
<p>Dataware P.O. Box 740947 Houston, TX 77274 U. S. A. Telephone: 800-426-4844 <a href="http://www.datawarelabels.com/">http://www.datawarelabels.com/</a></p>	<p>Dataware Labels Europe Heubergstrasse 9 D-83052 Bruckmuhl-Gotting Germany Telephone: 49 8062-9455 <a href="http://www.datawarelabels.com/">http://www.datawarelabels.com/</a></p>
<p>NetC P. O. Box 1067 Fairfield, CT 06825 U. S. A. Telephone: 203-372-6382 <a href="http://www.netc11c.com/">http://www.netc11c.com/</a></p>	<p>NetC Europe Ltd Town Farm Bungalow The Pavement North Curry TA3 6LX Somerset U. K. Telephone: 44 (0) 1823 49 1439 <a href="http://www.netclabels.co.uk">http://www.netclabels.co.uk</a></p>
	<p>NetC Asia Pacific Pty Ltd Locked Bag 1 Kenthurst NSW 2156 Australia Telephone: 61 (0) 2 4573 6556 <a href="http://www.netclabels.com.uk">http://www.netclabels.com.uk</a></p>



## Chapter 5. Resolving Problems

If you encounter problems when running the drive, refer to Table 5-1. If the problem is not identified in Table 5-1, refer to “Methods of Receiving Errors and Messages” on page 5-2. The color and condition of the Status Light may also indicate a problem. For more information, see “Status Light” on page 3-1

Table 5-1. Troubleshooting tips

If the problem is this....	Do this....
A code displays on the Single-character Display (SCD) and the Status Light flashes amber.	The drive detected an error or is directing you to an informational message. See Table 5-3 on page 5-3. If a code displays on the Single-character Display (SCD) and the Status Light is solid amber or off (i.e. not flashing), the drive is powering on, resetting, or in maintenance mode. See Chapter 3, “Operating the Drive,” on page 3-1
The Status Light or SCD never turns on.	The drive has no power. Check the power at the power source. Connect power to the drive (see “Connect and Test Power to the Drive” on page 2-11). If the problem persists, and the power source has been verified as good, replace the drive.
The drive will not load a tape cartridge.	<p>One of the following has occurred:</p> <ul style="list-style-type: none"> <li>• A tape cartridge is already inserted. To remove the cartridge, press the Unload Button. If the cartridge does not eject, turn off the power to the drive, then turn it back on. After the Status Light becomes solid green, press the Unload Button to eject the cartridge.</li> <li>• The tape cartridge was inserted incorrectly. To properly insert a cartridge, see “Inserting a Tape Cartridge” on page 3-4.</li> <li>• The tape cartridge may be an invalid media type or the cartridge may be defective. Check that the cartridge is a valid media type (see Chapter 4, “Using Ultrium Media,” on page 4-1). Insert another valid tape cartridge. If the problem exists for multiple valid cartridges, power cycle or reboot the drive. If the power cycle or reboot is successful, run the drive diagnostics (see “Diagnostic and Maintenance Functions” on page 3-5). If the power cycle or reboot is not successful, replace the drive.</li> <li>• The drive has no power. Connect power to the drive (see “Connect and Test Power to the Drive” on page 2-11).</li> <li>• The drive is in Maintenance Mode. See “Diagnostic and Maintenance Functions” on page 3-5.</li> </ul>
The drive will not unload the tape cartridge.	<ul style="list-style-type: none"> <li>• Make sure the tape is not in use. If an application is reading, writing, or rewinding a tape, or processing during a power-on or reboot, the tape will not unload immediately. Wait for the operation to complete.</li> <li>• If the tape is stuck or broken, press the Unload Button. If the cartridge does not eject, turn off the power to the drive, then turn it back on (note that the mid-tape recovery could take up to ten minutes to complete).</li> <li>• If the cartridge still does not eject, contact IBM Support</li> </ul>
The server received TapeAlert flags.	See your SCSI reference documentation.
The server reported SCSI problems (such as selection or command time-outs, or parity errors).	See “Fixing SCSI Bus Errors” on page 5-15.

Table 5-1. Troubleshooting tips (continued)

If the problem is this....	Do this....
The library reported an LDI or RS-422 communication problem with the drive.	The LDI or RS-422 circuitry may be defective. Run the LDI or RS-422 wrap test ("Function Code 7: Run RS-422 Wrap Test" on page 3-14). If the test runs successfully but the problem persists, refer to your library's service documentation.
Codes display on the SCD, but the Status Light does not turn on.	The Status Light does not turn on immediately during a power-on or reboot. During the power-on or reboot, random patterns will display on the SCD while the Status Light is not on. If a code displays on the SCD, but the Status Light does not turn on, refer to "Error Codes and Messages."
The drive does not respond to server commands.	Press and hold the Unload Button on the drive for ten seconds to force a drive dump. The drive will save the dump and then reboot to allow communication to the drive to occur. Do not cycle power, as this will erase the contents of the dump.

## Methods of Receiving Errors and Messages

Use this section as a guide for identifying error codes and message codes reported by the drive, its enclosure (if applicable), or the server.

**Note:** The codes on the Single-character Display (SCD) have different meanings, depending on whether they display during normal operations or while the drive is in maintenance mode. Codes that occur during normal operations are defined in Table 5-3 on page 5-3. Codes that occur while in maintenance mode are defined in "Diagnostic and Maintenance Functions" on page 3-5.

Table 5-2. Methods of receiving errors and messages

If the error or message was presented by....	Do this....
The enclosure's display (if the drive is enclosed in a library or autoloader)	Refer to the documentation for the enclosure.
The drive's SCD and the Status Light flashes amber	See Table 5-3 on page 5-3. To determine the meaning of Status Light activity, see "Status Light" on page 3-1.
The drive's SCD and the Status Light is solid amber	See "Diagnostic and Maintenance Functions" on page 3-5. To determine the meaning of Status Light activity, see "Status Light" on page 3-1.
SCSI log sense data (such as TapeAlert flags) and SCSI drive sense data at the server console	See Table 5-3 on page 5-3, or "Using Sense Data" on page 5-9.
Drive sense data sent to a library (if the drive is enclosed in a library)	Refer to your library's documentation, then see Table 5-3 on page 5-3.
The drive's error log	See Table 5-3 on page 5-3 and "Viewing the Drive Error Log" on page 5-14.

## Error Codes and Messages

Table 5-3 on page 5-3 gives descriptions of the errors and messages that pertain to the drive, and tells what to do when you receive them.

**Attention:** If the drive detects a permanent error and displays an error code other than  , it automatically performs a drive dump. If you force a drive dump, the existing dump will be overwritten and data will be lost. After you force a drive dump, do not turn off the power to the drive or you may lose the dump data.

Table 5-3. Error codes on the Single-character Display. To clear error and cycle power, press the Unload Button for ten seconds. A drive dump will be created.





Error Code	Cause and Action
	<p>No error occurred and no action is required. This code displays when diagnostics have finished running and no error occurred.:</p> <p><b>Note:</b> The Single-character Display is blank during normal operation of the tape drive.</p>
	<p>Temperature problem. The tape drive detected that the recommended operating temperature was exceeded. Perform one or more of the following actions:</p> <ul style="list-style-type: none"> <li>• Ensure that the cooling fan is rotating and is quiet. If not, refer to your enclosure documentation.</li> <li>• Remove any blockage that prevents air from flowing freely through the tape drive.</li> <li>• Ensure that the operating temperature and airflow is within the specified range (see “Physical Specifications” on page 1-11).</li> </ul> <p>Clear the error code by power cycling the tape drive or placing the drive in Maintenance Mode. If the operating temperature and airflow are within the specified range, and the problem persists, replace the drive.</p>
	<p>Power problem. The tape drive detected that the externally supplied power is outside the specified voltage limits (the tape drive is not operating). Perform the following action:</p> <ol style="list-style-type: none"> <li>1. Ensure that the power connector is properly seated.</li> <li>2. Ensure that the proper dc voltages are being applied within the tolerances allowed (see “Physical Specifications” on page 1-11).</li> <li>3. If the proper voltages are not being applied, service the power supply.</li> <li>4. If the proper voltages are being applied, power off/on the tape drive to see if the problem repeats.</li> <li>5. Replace the tape drive if the problem persists.</li> </ol> <p>The error code clears when you place the tape drive in maintenance mode.</p>
	<p>Firmware problem. The tape drive determined that a firmware error occurred. Perform the following action:</p> <ol style="list-style-type: none"> <li>1. Collect a drive dump from one of the following: <ul style="list-style-type: none"> <li>• Server’s host interface by using a device driver utility or system tool (for instructions about reading a drive dump from tape, visit the Web at <a href="http://www.ibm.com/storage/lto">http://www.ibm.com/storage/lto</a>)</li> <li>• Ultrium Tape Drive (to copy and read a drive dump, use “Function Code 5: Copy Drive Dump” on page 3-11)</li> </ul> </li> <li>2. Power the tape drive off and on, then retry the operation that produced the error.</li> <li>3. If the problem persists, download new firmware and retry the operation.</li> <li>4. If the problem persists, send the drive dump that you collected in step <b>1</b> to your IBM Support Center.</li> </ol> <p>The error code clears when you place the tape drive in maintenance mode.</p>

Table 5-3. Error codes on the Single-character Display (continued). To clear error and cycle power, press the Unload Button for ten seconds. A drive dump will be created.

Error Code	Cause and Action
4	<p>Firmware or hardware problem. The tape drive determined that a firmware or tape drive hardware failure occurred. Perform the following action:</p> <ol style="list-style-type: none"> <li>1. Collect a drive dump from one of the following: <ul style="list-style-type: none"> <li><b>Note:</b> Do not force a new dump; one already exists. <ul style="list-style-type: none"> <li>• Server's host interface by using a device driver utility or system tool (for instructions about reading a drive dump from tape, visit the Web at <a href="http://www.ibm.com/storage/lto">http://www.ibm.com/storage/lto</a>)</li> <li>• Ultrium Tape Drive (to copy and read a drive dump, use "Function Code 5: Copy Drive Dump" on page 3-11)</li> </ul> </li> </ul> </li> <li>2. Power the tape drive off and on, then retry the operation that produced the error. The error code clears when you place the tape drive in maintenance mode.</li> <li>3. If the problem persists, download new firmware and retry the operation; if new firmware is not available, replace the drive.</li> </ol>
5	<p>Tape drive hardware problem. The drive determined that a tape path or read/write error occurred. To prevent damage to the drive or tape, the tape drive will not allow you to insert a cartridge if the current cartridge was successfully ejected. The error code may clear when you cycle power to the tape drive or place it in maintenance mode. If the problem persists, replace the drive.</p> <p><b>Note:</b> Copy the drive dump to flash memory before returning the drive. For instructions, refer to "Function Code 5: Copy Drive Dump" on page 3-11.</p>
6	<p>Tape drive or media error. The tape drive determined that an error occurred, but it cannot isolate the error to faulty hardware or to the tape cartridge. Ensure the tape cartridge is the correct media type:</p> <ul style="list-style-type: none"> <li>• Ultrium -1 tape cartridges are not supported in Ultrium-4 tape drives.</li> <li>• Drive will not accept an expired Cleaning Cartridge.</li> <li>• Drive will not accept a WORM cartridge when running diagnostic tests in Maintenance Mode.</li> <li>• Drive will not write over existing datasets on a WORM cartridge. Ensure you are appending datasets on WORM media rather than attempting to write over existing datasets.</li> </ul> <p>If the tape cartridge is the correct media type, perform the following action:</p> <p><b>For Problems with Writing Data:</b></p> <p>If the problem occurred while the tape drive was writing data to the tape, retry the operation with a different cartridge:</p> <ul style="list-style-type: none"> <li>• If the operation succeeds, the original cartridge was defective. Copy data from the defective cartridge and discard it.</li> <li>• If the operation fails and another tape drive is available, insert the cartridge into the other unit and retry the operation. <ul style="list-style-type: none"> <li>– If the operation fails, discard the defective cartridge.</li> <li>– If the operation succeeds, insert a scratch data cartridge into the first unit and run "Function Code 1: Run Drive Diagnostics" on page 3-8. <ul style="list-style-type: none"> <li>- If the diagnostics fail, replace the tape drive.</li> <li>- If the diagnostics succeed, the error was temporary.</li> </ul> </li> </ul> </li> <li>• If the operation fails and another tape drive is not available, insert a scratch data cartridge into the unit and run "Function Code 1: Run Drive Diagnostics" on page 3-8. <ul style="list-style-type: none"> <li>– If the diagnostics fail, replace the tape drive.</li> <li>– If the diagnostics succeed, discard the cartridge.</li> </ul> </li> </ul>

Table 5-3. Error codes on the Single-character Display (continued). To clear error and cycle power, press the Unload Button for ten seconds. A drive dump will be created.

Error Code	Cause and Action
	<p>If the problem occurs with multiple tape cartridges, run "Function Code 1: Run Drive Diagnostics" on page 3-8:</p> <ul style="list-style-type: none"> <li>• If the diagnostics fail, replace the tape drive.</li> <li>• If the diagnostics succeed, run "Function Code H: Test Head" on page 3-18. <ul style="list-style-type: none"> <li>– If the diagnostic fails, replace the tape drive.</li> <li>– If the diagnostic succeeds, replace the cartridges that caused the problem.</li> </ul> </li> </ul> <p>The error code clears when you remove the tape cartridge or place the tape drive in maintenance mode.</p> <p><b><u>For Problems with Reading Data:</u></b></p> <p>If the problem occurred while the tape drive was reading data from the tape, perform one of the following procedures:</p> <ul style="list-style-type: none"> <li>• If another tape drive is available, insert the cartridge into the other unit and retry the operation: <ul style="list-style-type: none"> <li>– If the operation fails, discard the defective cartridge.</li> <li>– If the operation succeeds, insert a scratch data cartridge into the first unit and run "Function Code 1: Run Drive Diagnostics" on page 3-8: <ul style="list-style-type: none"> <li>- If the diagnostic fails, replace the tape drive.</li> <li>- If the diagnostic succeeds, the error was temporary.</li> </ul> </li> </ul> </li> <li>• If another tape drive is not available, insert a scratch data cartridge into the unit and run "Function Code 1: Run Drive Diagnostics" on page 3-8: <ul style="list-style-type: none"> <li>– If the diagnostic fails, replace the tape drive.</li> <li>– If the diagnostic succeeds, discard the cartridge.</li> </ul> </li> </ul> <p>If the problem occurs with multiple tape cartridges, run "Function Code 1: Run Drive Diagnostics" on page 3-8:</p> <ul style="list-style-type: none"> <li>• If the diagnostic fails, replace the tape drive.</li> <li>• If the diagnostic succeeds, run "Function Code H: Test Head" on page 3-18. <ul style="list-style-type: none"> <li>– If the diagnostic fails, replace the tape drive.</li> <li>– If the diagnostic succeeds, replace the cartridges that caused the problem.</li> </ul> </li> </ul> <p>The error code clears when you remove the tape cartridge or place the tape drive in maintenance mode.</p>

Table 5-3. Error codes on the Single-character Display (continued). To clear error and cycle power, press the Unload Button for ten seconds. A drive dump will be created.

Error Code	Cause and Action
7	<p>Media error. The tape drive determined an error occurred because of a faulty tape cartridge or an invalid tape cartridge. Ensure the tape cartridge is the correct media type:</p> <ul style="list-style-type: none"> <li>• Ultrium -1 tape cartridges are not supported in Ultrium-4 tape drives.</li> <li>• Drive will not accept an expired Cleaning Cartridge.</li> <li>• Drive will not accept a WORM cartridge when running diagnostic tests in Maintenance Mode.</li> <li>• Drive will not write over existing datasets on a WORM cartridge. Ensure you are appending datasets on WORM media rather than attempting to write over existing datasets.</li> <li>• Drive will not Create an FMR Tape (Maintenance Mode, Function Code 3) with a cartridge that is already an FMR tape. Use another cartridge or execute Maintenance Mode Function Code 8: Unmake FMR Tape.</li> <li>• Drive will not Unmake FMR Tape (Maintenance Code 8) with a cartridge that is not an FMR tape.</li> </ul> <p>If the tape cartridge is the correct media type, try another tape cartridge. If the problem occurs with multiple tape cartridges, use the following procedure:</p> <ol style="list-style-type: none"> <li>1. If possible, run the tape cartridge in a different tape drive. If the operation in the other unit fails and 6 or 7 displays, replace the media. If the operation succeeds, run "Function Code E: Test Cartridge &amp; Media" on page 3-16.</li> </ol> <p><b>Attention:</b> When you run the Test Cartridge &amp; Media diagnostic, data on the suspect tape is overwritten. Use only a scratch data cartridge to run the test.</p> <ul style="list-style-type: none"> <li>• If the diagnostic fails, replace the media.</li> <li>• If the diagnostic succeeds, clean the drive head (see "Cleaning the Drive Head" on page 3-5) and run "Function Code 1: Run Drive Diagnostics" on page 3-8. <ul style="list-style-type: none"> <li>– If the drive diagnostic fails, replace the drive.</li> <li>– If the drive diagnostic succeeds, perform the operation that produced the initial media error.</li> </ul> </li> </ul> <p>The error code clears when you remove the tape cartridge or place the tape drive in maintenance mode.</p>
8	<p>Interface problem. The tape drive determined that a failure occurred in the tape drive's hardware or in the host bus. See "Resolving Problems Reported by the Server" on page 5-14. If 8 was displayed while running "Function Code 6: Host Interface Test":</p> <ol style="list-style-type: none"> <li>1. Verify the correct interface wrap tool was attached during the test. The test will fail if the correct interface wrap tool is not attached.</li> <li>2. If the correct interface wrap tool was attached during the test, replace the drive. The error code clears when you place the tape drive in maintenance mode.</li> </ol> <p>1. 2. See "Fixing SCSI Bus Errors" on page 5-15. The error code clears 10 seconds after the drive detected the error or when you place the drive in maintenance mode.</p>
9	<p>Tape drive or RS-422 error. The tape drive determined that a failure occurred in the tape drive's hardware or in the RS-422 connection. See "Function Code 7: Run RS-422 Wrap Test" on page 3-14 or refer to the Library procedures to isolate the problem to the drive. The error code clears when you place the tape drive in maintenance mode.</p>

Table 5-3. Error codes on the Single-character Display (continued). To clear error and cycle power, press the Unload Button for ten seconds. A drive dump will be created.





Error Code	Cause and Action
	<p>Degraded operation. The tape drive determined that a problem occurred which degraded the operation of the tape drive, but it did not restrict continued use. If the problem persists, determine whether the problem is with the drive or the media.</p> <p><b>Note:</b> The drive is usable, though the Single-character Display continues to indicate an error and the Status Light flashes amber. The error code may clear when you cycle power to the tape drive or place it in maintenance mode.</p> <p>To determine if the problem is with the drive hardware, or the tape media, perform the following procedures:</p> <ol style="list-style-type: none"> <li>1. If possible, run the tape cartridge in a different drive. If the operation in the other drive fails and  or  displays, replace the media. If the operation succeeds, run the Test Cartridge &amp; Media diagnostic (see "Function Code E: Test Cartridge &amp; Media" on page 3-16).</li> <li>2. If the Test Cartridge &amp; Media diagnostic fails, replace the media. If it runs successfully, clean the failing drive and run the drive diagnostics (see "Cleaning the Drive Head" on page 3-5 and "Function Code 1: Run Drive Diagnostics" on page 3-8). Once you begin this test, the diagnostic begins the loop sequence. Time the first loop by pressing the Unload Button once to stop the diagnostic after the completion of the first loop, then record the time it takes for the test to complete. Compare the recorded time with the "Approximate Run Time" above. If the test runs successfully but the execution time is significantly longer than the "Approximate Run Time", run "Function Code F: Write Performance Test" on page 3-17. If the Write Performance Test fails, replace the media and exit maintenance mode. If the drive diagnostics run successfully, perform the operation that produced the initial drive error.</li> <li>3. If the problem persists replace the drive.</li> </ol> <p>If it is not possible to run the tape cartridge in a different drive, perform the following procedures:</p> <ol style="list-style-type: none"> <li>1. Clean the failing drive and run the drive diagnostics (see "Cleaning the Drive Head" on page 3-5 and "Function Code 1: Run Drive Diagnostics" on page 3-8). Once you begin this test, the diagnostic begins the loop sequence. Time the first loop by pressing the Unload Button once to stop the diagnostic after the completion of the first loop, then record the time it takes for the test to complete. Compare the recorded time with the "Approximate Run Time" above. If the test runs successfully but the execution time is significantly longer than the "Approximate Run Time", run "Function Code F: Write Performance Test" on page 3-17. If the Write Performance Test fails, replace the media and exit maintenance mode. If the drive diagnostics run successfully, run the Test Cartridge &amp; media diagnostic (see "Function Code E: Test Cartridge &amp; Media" on page 3-16).</li> <li>2. If the Test Cartridge &amp; Media diagnostic fails, replace the media. If it runs successfully, perform the operation that produced the initial drive error.</li> <li>3. If the problem persists replace the drive.</li> </ol>
	<p>The tape drive needs to be cleaned. Clean the tape drive. See "Cleaning the Drive Head" on page 3-5.</p> <p>The error code clears when you clean the tape drive or place it in maintenance mode.</p>
	<p>Fiber AL_PA conflict. Two drives on fiber loop have the same AL_PA. Modify the tape drive AL_PA to eliminate the conflict. See "Setting the Arbitrated Loop Physical Address (Fibre Channel Drive Only)" on page 2-4.</p>



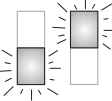

Table 5-3. Error codes on the Single-character Display (continued). To clear error and cycle power, press the Unload Button for ten seconds. A drive dump will be created.

Error Code	Cause and Action
<p style="text-align: center;">E</p>	<p>Encryption Error. Displayed when the drive detects an error associated with a encryption operation. If the problem occurred while the tape drive was writing data to, or reading data from, tape:</p> <ol style="list-style-type: none"> <li>1. Check the host application to ensure the host application is providing the correct encryption key. <ul style="list-style-type: none"> <li>• Refer to the IBM Tape Device Drivers Encryption Support documentation and the <i>IBM LTO Ultrium Tape Drive SCSI Reference</i> documentation for the Sense Data returned for an encryption operation.</li> <li>• Retry the encryption operation after the host application problems have been resolved.</li> </ul> </li> <li>2. Check the operation of the tape drive by resetting the drive and running POST. See Table 3-2 on page 3-3. <ul style="list-style-type: none"> <li>• Refer to the error code displayed on the SCD if the drive reset and POST fails.</li> <li>• Retry the encryption operation if the drive reset and POST complete without errors.</li> </ul> </li> <li>3. Check the media. <ul style="list-style-type: none"> <li>• Ensure the correct media is being used. Data encryption is supported with LTO Ultrium 4 Data Cartridges only.</li> <li>• Retry the encryption operation with the tape cartridge in another encryption enabled drive. Replace the media if the problem repeats with the same tape cartridge in multiple drives.</li> </ul> </li> </ol> <p>If the problem occurred while the tape drive was running POST or diagnostics, replace the drive.</p> <p>The error code clears with the first attempted write/read after the encryption key is changed, or when the drive is placed in maintenance mode.</p>
<p style="text-align: center;">E</p>	<p>Fiber Port offline. Displayed when the drive fiber port has received a 'port bypass' command from another port on the fiber channel network.</p> <ol style="list-style-type: none"> <li>1. Verify the fiber cables and connections, between the tape drive and the host, are the correct type and are working properly. Verify all equipment and devices are powered ON.</li> <li>2. Verify the configuraton settings for the drive are set correctly, and are compatible with the topology of the network.</li> <li>3. Verify the host fiber adapter and port are working properly, and are compatible with the topology of the network.</li> <li>4. Verify the fiber channel switch ports are working properly, and are compatible with the topology of the network.</li> <li>5. Verify the drive fiber cable and connector are plugged into port-0 of the tape drive. Refer to Chapter 1, "Product Description," on page 1-1.</li> <li>6. Verify tape drive fiber port-0 is working properly by running "Function Code 6: Run Host Interface Wrap Test" on page 3-12.</li> </ol> <p>The error code clears when communication is restored, or when you place the tape drive in maintenance mode.</p>



Table 5-3. Error codes on the Single-character Display (continued). To clear error and cycle power, press the Unload Button for ten seconds. A drive dump will be created.

Error Code	Cause and Action
	<p>Fiber Channel Error. No Light Displayed if the drive fiber port does not detect light.</p> <ol style="list-style-type: none"> <li>1. Verify the fiber cables and connections, between the tape drive and the host, are the correct type and are working properly. Verify all equipment and devices are powered ON.</li> <li>2. Verify the configuration settings for the drive are set correctly, and are compatible with the topology of the network.</li> <li>3. Verify the host fiber adapter and port are working properly, and are compatible with the topology of the network.</li> <li>4. Verify the fiber channel switch ports are working properly, and are compatible with the topology of the network.</li> <li>5. Verify the drive fiber cable and connector are plugged into port-0 of the tape drive. Refer to Chapter 1, "Product Description," on page 1-1.</li> <li>6. Verify tape drive fiber port-0 is working properly by running "Function Code 6: Run Host Interface Wrap Test" on page 3-12.</li> </ol> <p>The error code clears when the drive detects light, or when you place the tape drive in maintenance mode.</p>
	<p>Write operation to a write protected cartridge has been attempted (this includes any attempt to overwrite a WORM protected tape). Ensure the tape cartridge is the correct media type. Writes to Ultrium-2 tape cartridges are not supported in Ultrium-4 tape drives. If the tape cartridge is the correct media type, check the write-protect switch on the cartridge. The drive will not write to a write-protected cartridge. The error code clears when you remove the tape cartridge or place the tape drive in maintenance mode.</p>
	<p>Broken tape. Refer to the procedure for "Tape Pulled from or Broken near Leader Pin" on page A-6</p>

## Using Sense Data

When a drive encounters an error, it makes sense data available. You can use IBM device drivers to examine the sense data and determine errors. Instructions for downloading, installing, and properly configuring the IBM device drivers are available in the *IBM Ultrium Device Drivers Installation and User's Guide*. The IBM device drivers may conflict with some commercial software applications unless properly configured. To avoid conflicts on Windows operating systems, refer to your device driver's procedures for setting the driver to manual startup mode. For applications that use Open Systems device drivers that are provided by IBM (for example, AIX, Linux, Sun Solaris, HP-UX, Windows 2003, and Windows 2000), the *IBM Ultrium Device Drivers Installation and User's Guide* contains information about how to obtain sense data after an error has occurred.

If your application uses other device drivers, see the appropriate documentation for those drivers to obtain the sense data.

Raw sense data (as returned from the drive) is documented in the *IBM TotalStorage LTO Ultrium Tape Drive SCSI Reference*.

In addition to device drivers, other methods exist for obtaining sense data and error information. The sections that follow describe alternatives for gathering such information from the IBM AS/400, eServer iSeries, RS/6000®, and eServer pSeries® servers.

## Obtaining Error Information from the AS/400 or iSeries with RISC Processor

For OS/400, sense data is provided by the System Service Tools application. To obtain error information from the AS/400 or iSeries by using the tool:

1. On the command entry line of the AS/400 Main Menu, type **STRSST** (Start System Service Tools) and press Enter.
2. Select Start a service tool.
3. Select Product activity log.
4. Select Analyze log.
5. On the Select System Data menu, select the Magnetic media option then specify the time period for searching the error log.
6. On the Select Analysis Report Options menu, specify a Device selection of 3580 and press Enter. Leave all other options at their default values.
7. On the Log Analysis Report menu, select the Display report option to display the desired error log. Figure 5-1 shows a sample error log.

```

Display Detail Report for Resource

Name          Type      Model      Serial      Resource
TAP07         3580     002        00-00000    TAP07

Log ID . . . . . : 00452B54   Sequence . . . . . : 4732468
Date . . . . . : 08/14/02   Time . . . . . : 09:50:21
Reference code . . . . . : 9210   Secondary code . . . . . : 00000000
Table ID . . . . . : 63A00001   IPL source/state . . . . . : B/3

Class . . . . . : Permanent
System Ref Code . . . . . : 63A09210
Illegal or unsupported tape unit response

Press Enter to continue.

F3=Exit          F4=Additional Information   F6=Hexadecimal report
F9=Address Information  F10=Previous detail report  F12=Cancel
  
```

Figure 5-1. Example of an error log from the AS/400 or IBM eServer iSeries

8. Press F4 to view the sense data (see the example in Figure 5-2).

```

Display Additional Information for Resource

Name          Type      Model      Serial      Resource
TAP07         3580     002        00-00000    TAP07

SENSE DATA FOLLOWS. . . . . :
DATA OFFSET          0 1 2 3   4 5 6 7   8 9 A B   C D E F
00000000             70000500 0000001C 00000000 240000C0
00000010             00020000 00000000 00000000 00000000
00000020             058B0000
  
```

Figure 5-2. Example of sense data from the AS/400 or IBM eServer iSeries

## Obtaining Error Information from the RS/6000 or pSeries

The AIX® Tape and Media Changer Device Driver for the IBM RS/6000 or IBM eServer pSeries provides logging to the system error log for a variety of errors. You

can view the error log by issuing the AIX **errpt** command. Figure 5-3 on page 5-12 displays a sample drive error log; Figure 5-4 on page 5-13 displays a sample SCSI bus error log.

To view the error log:

1. At the AIX command line, type **errpt -a |pg** to display a detailed report.
2. Press Enter to scroll through the error log.
3. Type **q** to quit the error log at any time.

#### **Example of a Drive Error Log:**

In the SENSE DATA area of Figure 5-3 on page 5-12, entries in bold are defined as follows:

<b>Hexadecimal Code</b>	<b>Description</b>
01	SCSI Command
0000, 0200, 0000	Command parameters
70	Byte 0 of SCSI sense data
03	Sense key
5200	ASC/ASCQ (Additional Sense Code/Additional Sense Code Qualifier)
20B0	FSC (Fault Symptom Code)
058A	Relative LPOS
02	SCSI ID

```

LABEL:          TAPE_ERR1
IDENTIFIER:     4865FA9B

Date/Time:     Wed Oct 11 11:39:43
Sequence Number: 25264
Machine ID:    000D090D4C00
Node ID:      tsm
Class:        H
Type:         PERM
Resource Name: rmt2
Resource Class: tape
Resource Type: LTO
Location:     40-60-00-2,0
VPD:
  Manufacturer.....IBM
  Machine Type and Model.....ULT3580-TD2
  Serial Number.....1300015078
  Device Specific.(FW).....0B70 (Firmware Level)
Description
TAPE OPERATION ERROR

Probable Causes
TAPE

User Causes
MEDIA DEFECTIVE
DIRTY READ/WRITE HEAD

Recommended Actions
FOR REMOVABLE MEDIA, CHANGE MEDIA AND RETRY
PERFORM PROBLEM DETERMINATION PROCEDURES

Detail Data
SENSE DATA
0602 0000 0100 0000 0200 0000 0000 0000 0000 0000 0000 7000 0300 0000 001C 0000 0000
5200 0700 20B0 0000 0000 0000 0000 0000 0000 0000 0000 058A 0200 0000 0000 0000 0000
0000 0000 0000 0000 0000 0000 0000 0000 0000 0000 0000 0000 0000 0000 0000 0000
0000 0000 0000 0000 0000 0000 0000 0000 0000 0000 0000 0000 0000 0000 0000 0000
0000 0000 0000 0000 0000 0000 0000 0000 0000 0000 0000 0000 0000 0000 0000 0000

```

Figure 5-3. Example of an AIX ERRPT Drive Error Log

### Example of a SCSI Bus Error:

```

LABEL:          SCSI_ERR10
IDENTIFIER:     0BA49C99

Date/Time:      Wed Oct 18 09:55:32
Sequence Number: 16140
Machine Id:     00003ABF4C00
Node Id:        ofgtsm
Class:          H
Type:           TEMP
Resource Name:  scsi3
Resource Class: adapter
Resource Type:  sym896
Location:       40-59
VPD:
    Product Specific.( ).....DUAL CHANNEL PCI TO ULTRA2 SCSI
                          ADAPTER
    Part Number.....03N3606
    EC Level.....F71335
    Manufacture ID.....A16592
    Serial Number.....0749

Description
SCSI BUS ERROR

Probable Causes
CABLE
CABLE TERMINATOR
DEVICE
ADAPTER

Failure Causes
CABLE LOOSE OR DEFECTIVE
DEVICE
ADAPTER

Recommended Actions
PERFORM PROBLEM DETERMINATION PROCEDURES
CHECK CABLE AND ITS CONNECTIONS

Detail Data
SENSE DATA
0001 0017 0000 0000 0000 0091 0000 0000 0000 0000 0000 0000 0000 0000 0000
0000 0000 0000 4304 0000 0000 0000 0000 2000 0003 0203 6760 9808 0000 F7FB E1B8
0000 0015 000B 0210 0678 C800 0000 8200 8277 1B20 00A2 ED00 0000 0002 FFFF FFFF
00FF 0000 111F F000 F3DF F110

```

Figure 5-4. Example of an error that suggests a SCSI bus problem

## Obtaining a Drive Dump

You can obtain a drive dump by selecting a function code on the drive or by using a device driver utility (or a system tool) on the server. The sections that follow describe each method.

### Using ITDT

For information on obtaining a drive dump using the ITDT tool, refer to “ITDT Firmware Update, Dump Retrieval and Library/Drive Test Tool” on page 3-22.

### Using the Drive

To obtain a drive dump directly from the drive:

1. Make sure that no cartridge is in the drive.
2. Enter Maintenance Mode, see “Entering Maintenance Mode” on page 3-7.

3. Copy the drive dump to a scratch (blank) data cartridge. See "Function Code 5: Copy Drive Dump" on page 3-11.
4. Insert the tape into a drive.
5. From the server, issue the SCSI READ command to read the dump from the tape to a file or electronic image (you may need to issue the command several times to read the complete dump).
6. To determine where to send the file for analysis, contact your OEM Product Application Engineer (PAE).

## Using a Device Driver Utility

To obtain a drive dump by using a device driver utility, determine whether your server is installed with a utility that can read files from the server's memory. If it is, use that utility to obtain the drive dump.

For information about using IBM's utility programs to obtain drive dumps, see the *IBM Ultrium Device Drivers Installation and User's Guide*.

To determine where to send a file that contains a drive dump to be analyzed, contact your OEM Product Application Engineer (PAE).

---

## Viewing the Drive Error Log

The drive keeps an error log that you can use to identify and correct errors. The log contains the 10 most recent error codes, which appear (one at a time) on the Single-character Display (SCD).

To view the drive error log:

1. Make sure that no cartridge is in the drive.
2. Within two seconds, press the Unload Button three times. The Status Light becomes solid amber, which means that the drive is in maintenance mode.
3. Press the Unload Button once per second until  appears in the SCD.
4. Press and hold the Unload Button for three seconds to view the most recent error code.
5. Refer to Table 5-3 on page 5-3 to determine the meaning of the code and the action to take.
6. Press the Unload Button to view the next error code. (The codes are ordered; the most recent is presented first and the oldest (tenth) is presented last.)
7. Continue to press the Unload Button until the ten error codes have been displayed. After you display the tenth error code, the drive automatically exits maintenance mode.

To redisplay the error codes, repeat steps 11 through 7.

---

## Resolving Problems Reported by the Server

The procedure for fixing interface bus errors varies, depending on whether the error is consistent or intermittent, and whether your configuration contains single or multiple drives. The sections that follow describe how to fix each type of error.

## Fixing SCSI Bus Errors

**Note:** If you are using a Storage Area Network (SAN) Data Gateway to convert a drive with a SCSI interface to a Fibre Channel interface, ensure that the problem is occurring between the SAN Data Gateway and the drive by running the SCSI wrap test on the drive and running the SCSI loopback test on the SAN Data Gateway. (To run the SCSI wrap test, see “Function Code 6: Run Host Interface Wrap Test” on page 3-12; to run the SCSI loopback test, refer to the section about that test in the *IBM Storage Area Network Gateway Module Setup, Operator, and Service Guide*.)

### Fixing a Consistent Error with a Single Drive on a SCSI Bus

1. Ensure that the power is on to the drive.
2. Ensure that the drive’s SCSI address is the same as the SCSI address assigned by the server.
3. Run the SCSI wrap test (see “Function Code 6: Run Host Interface Wrap Test” on page 3-12)
  - If the test fails, replace the SCSI terminator first, then the SCSI cable and the interposer (if installed). Repeat the operation that caused the error. If you replaced the SCSI terminator or SCSI cable and the problem persists, the fault is with the server’s hardware or software. To isolate the cause of the failure, refer to the server’s service documentation.
  - If the test fails again, replace the drive (see “Removing a SCSI Drive from an Enclosure” on page A-1).
  - If the test is successful, refer to your enclosure documentation for additional troubleshooting information.

### Fixing a Consistent Error with Multiple Drives on a SCSI Bus

When a consistent error occurs in a configuration that has multiple drives on the SCSI bus, you must determine if the problem exists with more than one drive. If the problem is with all of the devices on the SCSI bus, the bus is stuck in a SCSI phase and cannot change to another phase or the SCSI cable from the server to the first device is defective.

1. Ensure that the SCSI cable from the server to the first device is connected.
2. Disconnect all but the first drive on the SCSI bus. Move the terminator to the first SCSI device.
3. Run a device driver utility (such as IBM’s *ntutil* or *tapetutil*) to determine whether the error will occur.
  - If the error occurs, run the SCSI wrap test on the first drive (see “Function Code 6: Run Host Interface Wrap Test” on page 3-12).
    - If the test runs successfully, replace the SCSI terminator first, then the SCSI cable and the interposer (if installed) to the first drive. Repeat the operation that caused the error. If you replaced the SCSI terminator or SCSI cable and the problem persists, the fault is with the server’s hardware or software. To isolate the cause of the failure, refer to the server’s service documentation.
    - If the test fails, replace the drive (see “Removing a SCSI Drive from an Enclosure” on page A-1).
  - If the error does not occur, connect one drive at a time back to the bus and repeat step 3 for each drive until you can identify which drive is defective.

**Note:** Ensure that the SCSI terminator is always on the last drive on the SCSI bus.

4. Determine if the problem is with only one drive or with two or more drives.
  - If the problem is with only one drive, run the SCSI wrap test on that drive (see “Function Code 6: Run Host Interface Wrap Test” on page 3-12).
    - If the test runs successfully, replace the SCSI terminator first, then the SCSI cable to that drive and interposer (if installed).
    - If the test fails, replace the drive (see “Removing a SCSI Drive from an Enclosure” on page A-1).
  - If the problem is with two or more drives, locate the first drive that has the error and replace the SCSI cable that connects the drive and the interposer (if installed).

### **Fixing an Intermittent Error with a Single Drive on a SCSI Bus**

1. Replace the SCSI terminator on the drive.
2. Run the operation that caused the error. If the problem persists, the problem may be with the cable.
3. Isolate which cable is causing the problem by replacing one cable at a time and running the operation that caused the error after each replacement. If the problem persists after all cables have been replaced, the problem may be with the drive.
4. Replace the drive (see “Removing a SCSI Drive from an Enclosure” on page A-1). If the problem persists, the problem is with your server. Consult your server’s documentation.

### **Fixing an Intermittent Error with Multiples Drives on a SCSI Bus**

Refer to the server’s error logs to determine which drive is the source of the problem:

- If only one drive is reporting a SCSI failure, replace that drive (see “Removing a SCSI Drive from an Enclosure” on page A-1).
- If multiple drives are reporting SCSI failures, the problem may be with the terminator or the SCSI cables:
  - Replace the terminator and run the operation that caused the error. If the problem persists, the problem may be with the cables.
  - Isolate which cable is causing the problem by replacing one cable at a time and run the operation that caused the error after each replacement.

## **Fixing Fibre Channel Errors**

If you are connected to a Fibre Channel Storage Area Network (SAN) by using a SAN Data Gateway, use the *IBM Storage Area Network Gateway Module Setup, Operator, and Service Guide* to determine whether the problem is occurring between the drive and the SAN Data Gateway. If you are using a SCSI drive and are having SCSI problems, see “Fixing SCSI Bus Errors” on page 5-15.

### **Starting Problem Determination**

Before starting the problem determination, perform the following steps:

1. Determine the type of Fibre Channel topology that you are using (see page “Supported Topologies” on page 1-9). Ensure that the drive and the port to which it is attached are configured in compatible topologies.



2. Using this guide or the service guides of associated switch, hub, or fiber products, try to determine where the problem exists (whether in the drive, cable, or the device to which the drive and cable attach).
3. Ensure that the configuration and software levels are supported (see “Fibre Channel Interface” on page 1-8).
4. Ensure that the Fibre Channel cables are installed correctly. Refer to the appropriate steps in Chapter 2, “Installing the Drive,” on page 2-1.
5. Go to one of the following procedures:
  - “Fixing a Consistent Error with a Single Drive on a Fibre Channel Loop”
  - “Fixing a Consistent Error with Multiple Drives on a Fibre Channel Loop”
  - “Fixing a Consistent Error in a Point-to-Point Topology” on page 5-18
  - “Fixing Intermittent Fibre Channel Errors” on page 5-18

### **Fixing a Consistent Error with a Single Drive on a Fibre Channel Loop**

1. Ensure that the tape drive is powered on.
2. Verify that the tape drive’s serial number is the same as the drive serial number that the server program is using.
3. Ensure that the drive’s Fibre Channel AL\_PA is set correctly, that it is on the loop, and that it is not being used by another device (see “Setting the Arbitrated Loop Physical Address (Fibre Channel Drive Only)” on page 2-4 ). The tape drive must be able to detect light and communicate with the server.
4. Run the Fibre Channel wrap test at the drive’s Fibre Channel connector (see Function Code 6 “Function Code 6: Run Host Interface Wrap Test” on page 3-12).
  - If the test fails, replace the tape drive.
  - If the test is successful, go to step 5.
5. Run the Fibre Channel wrap test at the end of the fiber cable (see Function Code 6 in “Function Code 6: Run Host Interface Wrap Test” on page 3-12).
  - If the test fails, replace the fiber cable.
  - If the test is successful, go to step 6.
6. Check the Fibre Channel cable connection at the server.
7. Using a device driver utility such as *ntutil* or *tapeutil*, verify that the drive is properly configured and available at the server.
8. If the problem persists, the fault may be with the server’s hardware or software. Refer to your server’s service manual.
9. When the problem is corrected (or determined to be a server problem), restore all of the fiber cables to their correct position.

### **Fixing a Consistent Error with Multiple Drives on a Fibre Channel Loop**

Use the following procedure to determine if all of the drives on the Fibre Channel have the problem:

1. Use a device driver utility (such as *ntutil* or *tapeutil*) to verify that the drive is available and properly configured at the server.
2. Determine the type of Fibre Channel topology that you are using (see page “Supported Topologies” on page 1-9).

3. Using this guide or the service guides of associated switch, hub, or fiber products, try to isolate which part of the Fibre Channel Storage Area Network (SAN) is experiencing problems.
4. Perform one of the following:
  - If the problem exists on a small number of drives, go to “Fixing a Consistent Error with a Single Drive on a Fibre Channel Loop” on page 5-17.
  - If the problem exists with a large number of drives, perform the following steps:
    - a. Disconnect all except one failing drive on the Fibre Channel.
    - b. Run the Fibre Channel wrap test to determine if a failure occurs on that drive (see Function Code 6 in “Function Code 6: Run Host Interface Wrap Test” on page 3-12). If it does, perform the procedure in “Fixing a Consistent Error with a Single Drive on a Fibre Channel Loop” on page 5-17.
    - c. Continue to connect one drive at a time to the Fibre Channel loop.
5. When the problem is corrected, restore all of the Fibre Channel cables to their correct position.

### **Fixing a Consistent Error in a Point-to-Point Topology**

1. Ensure that the tape drive is powered on.
2. Verify that the tape drive’s serial number is the same as the drive serial number that the server program is using.
3. Ensure that the drive is connected to the host or switch. The drive must be able to detect light and communicate with the server.
4. Run the Fibre Channel wrap test at the drive’s Fibre Channel connector (see Function Code 6 in “Function Code 6: Run Host Interface Wrap Test” on page 3-12)
  - If the test fails, replace the tape drive.
  - If the test is successful, go to step 5.
5. Run the Fibre Channel wrap test at the end of the fiber cable (see Function Code 6 in “Function Code 6: Run Host Interface Wrap Test” on page 3-12)
  - If the test fails, replace the fiber cable.
  - If the test is successful, go to step 6.
6. Check the Fibre Channel cable connection at the server.
7. Using a device driver utility such as *ntutil* or *tapeutil*, verify that the drive is properly configured and available at the server.
8. If the problem persists, the fault may be with the server’s hardware or software. Refer to your server’s service manual.
9. When the problem is corrected (or determined to be a server problem), restore all of the fiber cables to their correct position.

### **Fixing Intermittent Fibre Channel Errors**

1. Determine the type of Fibre Channel topology that you are using (see page “Supported Topologies” on page 1-9).
2. Ensure that the configuration and software levels are supported (see “Fibre Channel Interface” on page 1-8).
3. Check that each Fibre Channel cable does not exceed 500 m (1640 ft).
4. Ensure that all Fibre Channel cables are installed correctly. Refer to the appropriate steps in Chapter 2, “Installing the Drive,” on page 2-1.

5. Using this guide or the service guides of associated switch, hub, or fiber products, determine that a problem exists between the drive, drive cable, and the device to which they attach. Try to isolate which part of the Storage Area Network (SAN) is experiencing problems.
6. Using this guide or the service guides of associated switch, hub, or fiber products, verify that the SAN configurations are correct (such as switch zoning for drive sharing).
7. Obtain all errors reported by the drive to the server (see “Using Sense Data” on page 5-9), then contact your OEM Product Application Engineer (PAE) for error analysis.

---

## Resolving Media-Related Problems

To resolve problems that are related to media, the drive’s firmware includes:

- Test Cartridge & Media diagnostic that verifies whether a suspect cartridge and its magnetic tape are acceptable for use.
- Statistical Analysis and Reporting System (SARS) to assist in isolating failures between media and hardware. To determine the cause of failure, SARS uses the cartridge performance history that is saved in the cartridge memory (CM) and the drive performance history that is kept in the drive’s VPD (Vital Product Data) area in NVRAM. Any failures that SARS detects are reported as TapeAlert flags on the server (see *IBM LTO Ultrium Tape Drive SCSI Reference*).

**Attention:** If you insert the IBM LTO Ultrium Data Cartridge into another manufacturer’s drive, the SARS data in the cartridge memory may become lost or invalid.

If you encounter a media-related problem, refer to “Function Code E: Test Cartridge & Media” on page 3-16.



---

## Chapter 6. Parts List

Table 6-1 lists the tools and supplies that you can use with the IBM LTO Ultrium 4 Tape Drive. To order tools and supplies, contact your OEM Product Application Engineer (PAE) or visit the web at <http://www.ibm.com/storage/lto>.

For information on ordering media and bar code labels, see “Ordering Media Supplies” on page 4-18.

*Table 6-1. Tools and supplies for the IBM LTO Ultrium 4 Tape Drive*

Type	IBM Part Number	Product Description
SCSI	19P0874	SCSI LVD terminator
	19P0481	SCSI LVD wrap plug
Fibre Channel	12R9314	Single port Fibre Channel wrap plug
	95P2694	Fibre Channel duplex adapter



---

## Information for Authorized Service Personnel

### Attention:

- It is strongly recommended that the drive and stuck tape be returned to IBM for removal and recovery.
- These procedures must be performed only by a trained IBM service provider. SSRs should claim their time against service code 33 ECA 013 when performing this procedure.
- Inform the customer the following procedure has high risk of damaging the drive and high risk of loss of data.

---

## Removing a Drive from an Enclosure

Depending on the type of enclosure, removal procedures may vary. The following generic procedure can be used if the enclosure documentation is not available for the different enclosure types.

### Removing a SCSI Drive from an Enclosure

To remove a SCSI drive from an enclosure, perform the following steps:

1. Ensure that the drive does not contain a tape cartridge.
2. Deconfigure the drive from the server (for instructions, see your server's documentation).
3. Turn off the power to the enclosure. Disconnect the power cable from the enclosure and the electrical outlet.
4. Remove the cover of the enclosure.
5. Disconnect the internal power cable from the power connector (see **3** in Figure 1-3 on page 1-3).
6. If connected, disconnect the library interface (ADI or LDI) connector (see **4** in Figure 1-3 on page 1-3).
7. Disconnect the internal SCSI cable from the SCSI connector (see **1** in Figure 1-3 on page 1-3).
8. Perform one of the following procedures on the SCSI ID connector (see **2** in Figure 1-3 on page 1-3).
  - If your enclosure uses an internal SCSI ID switch, disconnect it from the SCSI ID connector.
  - If your enclosure uses jumpers to set the SCSI ID, do not remove them from the connector.
9. Remove the mounting screws from the side brackets of the chassis (see **2** in Figure 2-5 on page 2-11).
10. Remove the drive from the enclosure.
11. To reassemble, reverse these steps.

### Removing a Fibre Channel Tape Drive from an Enclosure

To remove a fibre channel drive from an enclosure, perform the following steps:

1. Ensure that the tape drive does not contain a tape cartridge.

2. Deconfigure the drive from the server, switch, or hub (for instructions, see the documentation for these devices).
3. Turn off the power to the enclosure. Disconnect the power cable from the enclosure and the electrical outlet.
4. Disconnect the internal power cable from the power connector (see **1** in Figure 1-4 on page 1-3).
5. If connected, disconnect the library interface (ADI or LDI) connector (see **7** in Figure 1-4 on page 1-3).
6. Disconnect the internal fiber cable from the Fibre Channel connector (see **5** in Figure 1-4 on page 1-3).
7. Disconnect the LID/status connector (see **3** in Figure 1-4 on page 1-3).
8. Disconnect the FC configuration/status connector (see **4** in Figure 1-4 on page 1-3).
9. Remove the mounting screws from the side brackets of the chassis (see **2** in Figure 2-5 on page 2-11).
10. Remove the tape drive from the enclosure.
11. To reassemble, reverse these steps.

## Removing a SAS Drive from an Enclosure

To remove a SAS drive from an enclosure, perform the following steps:

1. Ensure that the drive does not contain a tape cartridge.
2. Deconfigure the drive from the server (for instructions, see your server's documentation).
3. Turn off the power to the enclosure. Disconnect the power cable from the enclosure and the electrical outlet.
4. Remove the cover of the enclosure.
5. Disconnect the internal power cable from the power connector (see **2** in Figure 1-5 on page 1-4).
6. If connected, disconnect the library interface (ADI or LDI) connector (see **3** in Figure 1-5 on page 1-4).
7. Disconnect the internal SAS cable from the SAS connector (see Figure 1-5 on page 1-4).
8. Remove the mounting screws from the side brackets of the chassis (see **2** in Figure 2-5 on page 2-11).
9. Remove the drive from the enclosure.
10. To reassemble, reverse these steps.



---

## Manually Removing a Tape Cartridge

The purpose of this section is to assist you in determining the condition of the cartridge or the magnetic tape and to direct you to the procedure you must follow to remove the cartridge.

### Attention:

- **The best solution for recovering data on a damaged cartridge is to send it to IBM for professional data recovery.**
- Before using this procedure, you must have exhausted all other means of removing the tape cartridge from the drive. Use this procedure **only** if you cannot remove the tape cartridge by using any other means.
- Determine from the customer if the cartridge contains **critical customer data**. If the cartridge contains sensitive data that cannot leave the site, inform the customer that certain failure conditions diagnostics will be performed to test the drive for continued use.
- The following removal procedures **can destroy** customer data! Use **extreme care** when handling or removing the customer's tape cartridges to minimize tape damage and lost data.
- **DO NOT TOUCH** the magnetic tape or tape path. Both are extremely sensitive to the oil and salt from your skin. Use clean, lint-free gloves when working around magnetic tape or the tape path components.
- Electrostatic-sensitive components: Consider using an ESD Kit.
- After you remove the tape cartridge, advise the customer to copy the data to another cartridge and to remove this tape cartridge from service.
- Do not use power tools or magnetic tools to perform this procedure.
- To avoid contamination and electrostatic-discharge damage to the drive, never touch the head or electronic components inside the drive.
- If you cannot remove the cartridge from the drive using the following procedures, contact your next level of support.
- The cartridge will not eject automatically at the end of a mid-tape recovery. Instead, the tape will be reloaded into the drive and may result in the loss of data.
- **INTERNAL COMPONENTS OF THE DRIVE ARE DELICATE AND CAN EASILY BE DAMAGED. EXERCISE EXTREME CAUTION WHEN MANUALLY REMOVING A CARTRIDGE THAT WILL NOT EJECT AFTER PRESSING THE UNLOAD BUTTON.**

### Before You Begin

1. If you have not already done so, attempt to remove the cartridge with the device power ON and using library manager, a host application, or the Unload Button.
2. If you have not already done so, attempt to remove the cartridge by power cycling the drive. Look for the drive to attempt a mid-tape recovery.

**Note:** It can take as long as five minutes for the cartridge to rewind and unload.

3. If the cartridge unloads, inform the operator that the cartridge is unloaded. If the cartridge does not unload, continue with this procedure.



tape appears to be on the take up reel. The leader block is positioned in the take up reel. Return the drive after the procedure is completed.

- **Tape broken in mid-tape** - Tape appears to be on both the supply reel (inside the cartridge) and take up reel. Test the drive after the procedure is completed.
- **Tape tangled along tape path** - Tape appears to be tangled and damaged but in tact. Return the drive after the procedure is completed.

-- OR --

**No damage to tape (or no apparent failure)** - There appears to be no damage or slack to the tape. Return the drive after the procedure is completed.

## Tape Spooled Off Supply Reel

1. With the front of the drive facing you, pull an arm's length of tape out of the take up reel from the left side of the drive.
2. From the take up reel, thread tape around the rear of the tape path and over the head and rollers on the left side of the drive.
3. Set the drive on its left side with the head and tape path facing up.
4. Moisten a cotton swab with water and wet approximately 13 mm (0.5 in.) of the tape end and feed it onto the supply reel (inside the cartridge).
5. From the bottom of the drive, insert a 2.5 mm offset hex wrench through the bottom cover access hole and into the reel motor axle.

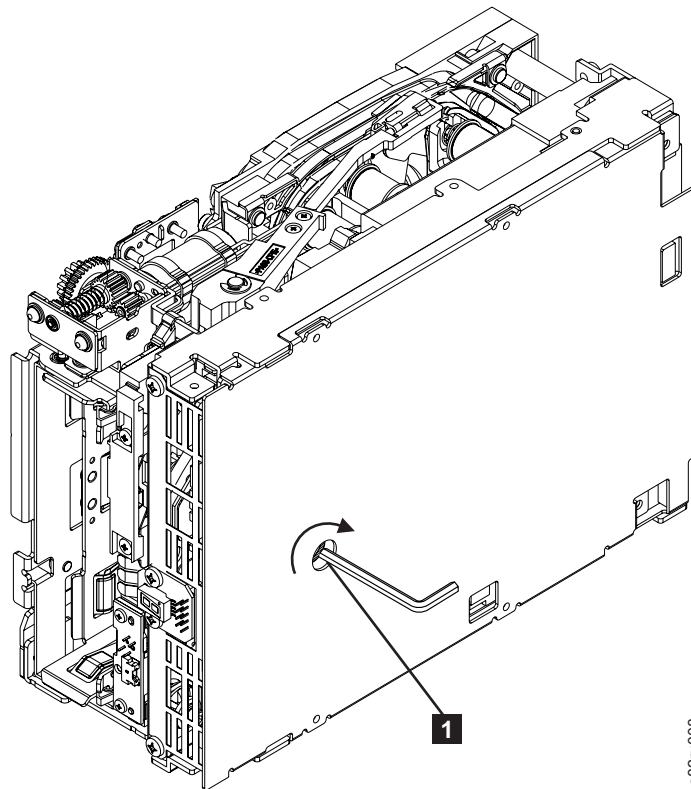
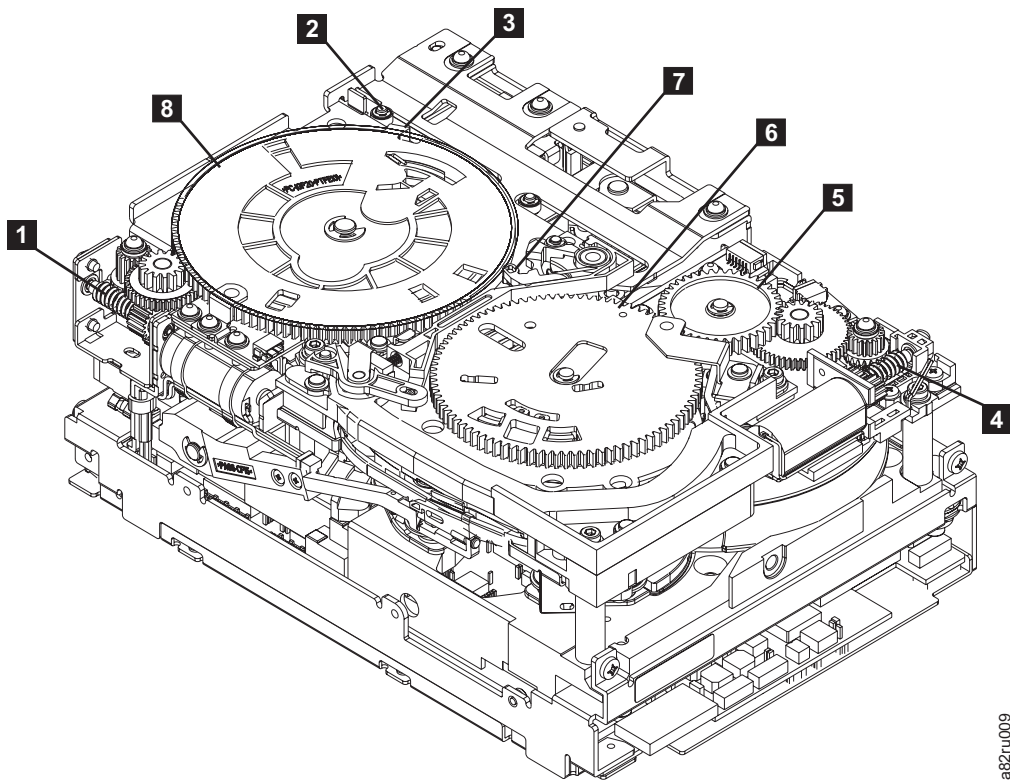

Figure A-2. Using hex wrench to rewind tape into cartridge

6. Turn the supply reel clockwise, allowing the moistened tape to adhere to the hub as it winds around the supply reel (inside the cartridge).

7. Continue spooling into the cartridge until the tape is taut and remains within the flanges of the tape guiding rollers. Ensure that you do not stretch the tape.
8. Reassemble the drive, reversing the steps in "Beginning Procedure" on page A-4.
9. Allow the drive to perform mid-tape recovery. This takes several minutes. When this activity completes, the cartridge ejects automatically.
10. Test the drive (see "Function Code 1: Run Drive Diagnostics" on page 3-8) to determine if it should be replaced.

## Tape Pulled from or Broken near Leader Pin



a82ru009

Figure A-3. Drive with cover removed to reveal gear train.

<b>1</b>	Loader motor worm gear	<b>6</b>	Threader mechanism gear
<b>2</b>	Cartridge loader tray guide bearing	<b>7</b>	Lever
<b>3</b>	Rotator stub	<b>8</b>	Loader mechanism gear
<b>4</b>	Threader motor worm gear		
<b>5</b>	Threader intermediate gear		

1. From the left side of the drive, pull out tape from the take up reel.

**Note:** If there is more than approximately 0.6 m (2 ft.) of tape on the take up reel, go to "Tape Broken in Mid-tape" on page A-8.

2. If there is less than approximately 0.6 m (2 ft.) of tape on the take up reel, cut off the excess tape as close to the leader pin, as possible.

3. Locate the threader motor worm gear ( **4** in Figure A-3 on page A-6) the rear of the drive. Use your finger to rotate the threader motor worm gear and slowly rotate the threader mechanism gear ( **6** in ) clockwise.. This rotates the threader motor worm gear ( **4** in Figure A-3 on page A-6) clockwise, drawing the tape leader block assembly (LBA) into the cartridge.
4. As the LBA is secured in the cartridge, you should hear the LBA retention spring clips click into place. If you do not hear the click, continue rolling until the threader motor worm gear ( **4** in Figure A-3 on page A-6) stops. The LBA is in the correct position.

**Note:** Be sure to keep tension on the tape as the LBA is drawn into the cartridge by using a hex wrench as shown in Figure A-2 on page A-5.

5. Notice the following:
  - a. Loader mechanism gear ( **8** in Figure A-3 on page A-6) nearest the front of the drive that actuates the cartridge loader mechanism
  - b. Position of the rotator stub ( **3** in Figure A-3 on page A-6).
  - c. Front loader motor worm gear ( **1** in Figure A-3 on page A-6). Rotating this gear allows the loader mechanism gear ( **8** in Figure A-3 on page A-6) to turn.
6. Rotate the loader motor worm gear ( **1** in Figure A-3 on page A-6) to turn the loader mechanism gear ( **6** in Figure A-3 on page A-6) counterclockwise. Continue turning until the rotator stub ( **3** in Figure A-3 on page A-6) loses contact with the lever ( **7** in Figure A-3 on page A-6). This releases the LBA leader pin.
7. Rotate the threader motor worm gear ( **4** in Figure A-3 on page A-6) to turn the threader mechanism gear ( **6** in Figure A-3 on page A-6) counterclockwise. This moves the LBA out of the cartridge and past the read/write head. Stop this rotation when the LBA is near the tape guide roller nearest the rear of the drive ( **1** in Figure A-4).

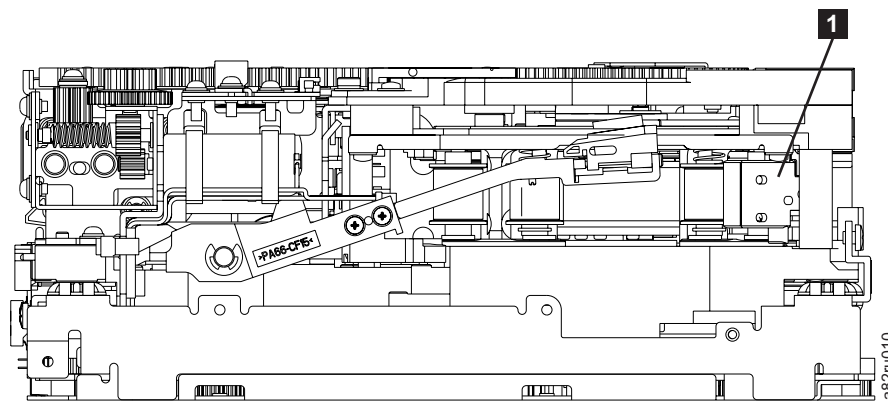

Figure A-4. Leader Block Assembly (LBA)

8. Continue rotating the loader motor worm gear ( **1** in Figure A-3 on page A-6) until the rotate stub ( **3** in Figure A-3 on page A-6) is positioned as shown. Notice that the rotator stub ( **3** in Figure A-3 on page A-6) is nearly aligned with the cartridge loader tray guide bearing ( **2** in Figure A-3 on page A-6).
9. Remove the cartridge from the cartridge loader tray.
10. Reassemble the drive by reversing the procedure in Step 4 on page A-4 in "Beginning Procedure" on page A-4.

11. Refer to the appropriate procedure to install the new drive and return the failed drive.

## Tape Broken in Mid-tape

1. With the front of the drive facing you, pull an arm's length of tape out of the take up reel from the left side of the drive.

**Note:** If there is less than approximately 5 cm (2 in.) of tape on the take up reel, go to "Tape Pulled from or Broken near Leader Pin" on page A-6.

2. From the supply reel inside the cartridge, pull approximately 0.3 m (1 ft.) of tape.
3. From the take up reel, thread tape around the rear of the tape path and over the head rollers on the left side of the drive.
4. Moisten a cotton swab with water, and wet approximately 13 mm (0.5 in.) of the tape end. Overlap the tape ends, loosely mending them together.
5. Set the drive on its left side with the head and tape path facing up.
6. From the bottom of the drive, locate the access hole ( **1** in Figure A-5) in the bottom cover. Insert a 2.5 mm offset hex wrench through the bottom cover access hole and into the reel motor axle. begin spooling tape back into the cartridge by turning the hex wrench clockwise.

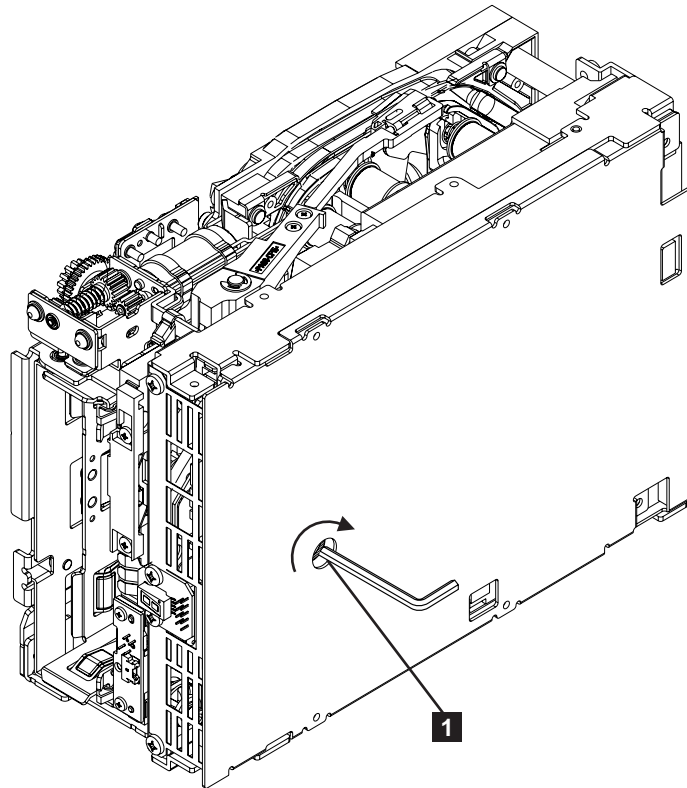

Figure A-5. Using hex wrench to rewind tape into cartridge

7. Turn the supply reel clockwise, carefully guiding the mended portion of the tape to wind around the hub of the supply reel located inside the cartridge. Continue spooling into the cartridge until the tape is taut. The tape must remain within the flanges of the tape guiding rollers. Ensure that you do not stretch the tape.

8. Reassemble the drive by reversing the procedure in Step4 on page A-4 in "Beginning Procedure" on page A-4.
9. Allow the drive to perform mid-tape recovery. This takes several minutes. When this activity completes, the cartridge ejects automatically.
10. Test the drive (see "Function Code 1: Run Drive Diagnostics" on page 3-8) to determine if it should be replaced.

## Tape Tangled along Tape Path

1. Carefully pull out excess tape and untangle.

**Note:** If you find the tape to be broken, go to one of the following appropriate procedures:

- "Tape Spooled Off Supply Reel" on page A-5
- "Tape Pulled from or Broken near Leader Pin" on page A-6

--OR--

"Tape Broken in Mid-tape" on page A-8

2. Set the drive on its left side with the head and tape path facing up.

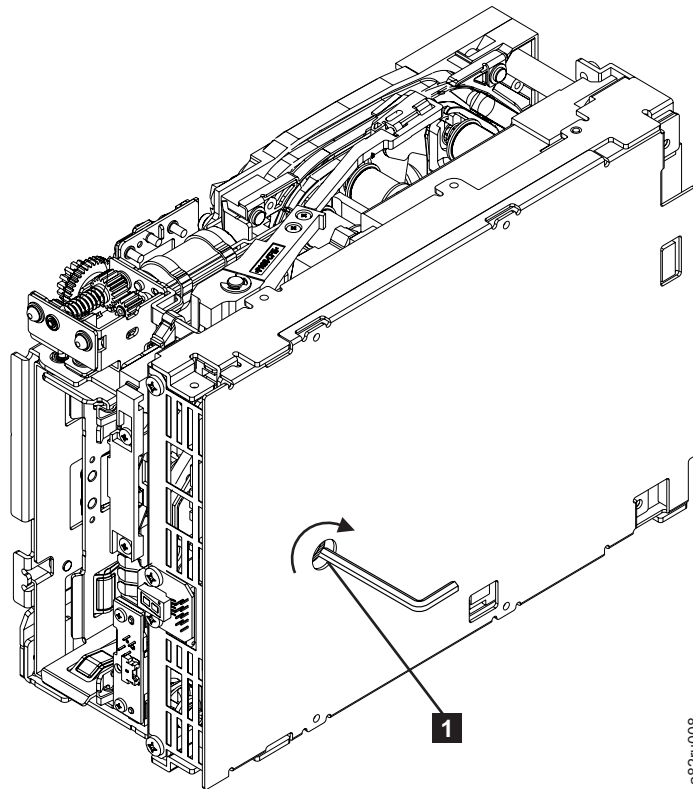
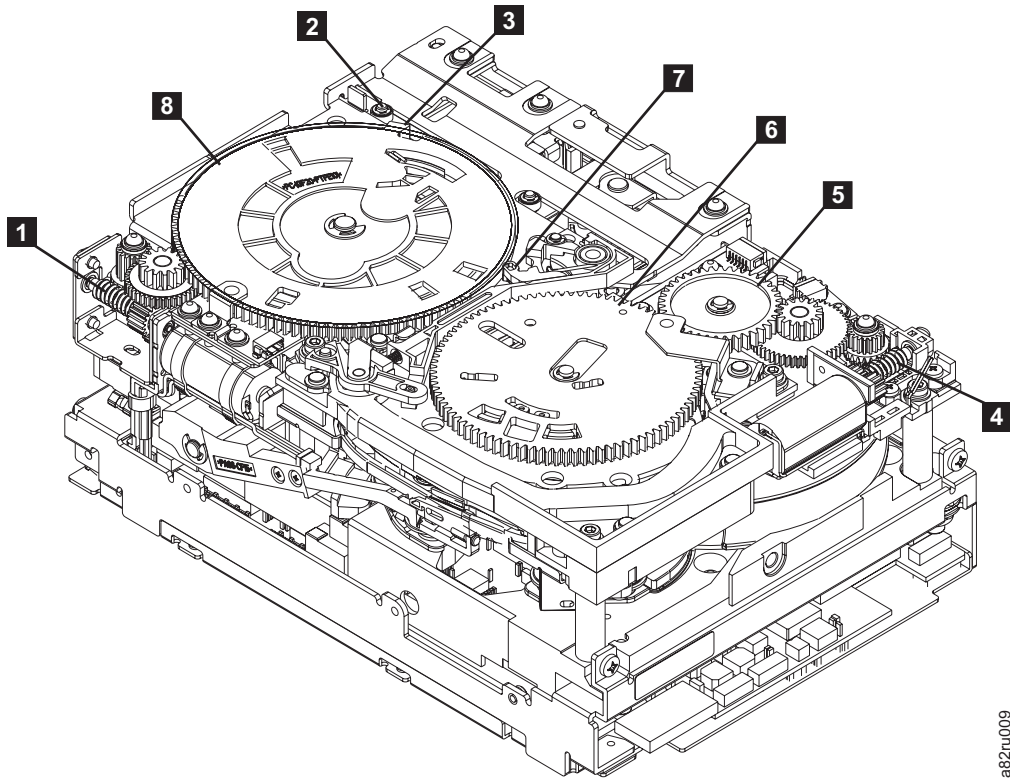

Figure A-6. Using hex wrench to rewind tape into cartridge

3. From the bottom of the drive, locate the access hole ( **1** in Figure A-6).
4. Insert a 2.5 mm offset hex wrench through the bottom cover access hole and into the reel motor axle. Begin spooling the tape back into the cartridge by turning the hex wrench clockwise.
5. Continue spooling into the cartridge until the tape is taut and remains within the flanges of the tape guiding rollers. Ensure that you do not stretch the tape.



6. Locate the threader motor worm gear ( **4** in Figure A-7) on the rear of the drive. Use your finger to rotate the threader motor worm gear and slowly rotate the threader mechanism gear ( **6** in Figure A-7) clockwise. This rotates the threader motor worm gear ( **4** in Figure A-7) clockwise, drawing the LBA into the cartridge.



a82tu009

Figure A-7. Drive with cover removed to reveal gear train.

<b>1</b>	Loader motor worm gear	<b>6</b>	Threader mechanism gear
<b>2</b>	Cartridge loader tray guide bearing	<b>7</b>	Lever
<b>3</b>	Rotator stub	<b>8</b>	Loader mechanism gear
<b>4</b>	Threader motor worm gear		
<b>5</b>	Threader intermediate gear		

7. As the tape leader block assembly (LBA) is secured in the cartridge, you should hear the LBA retention spring clips click into place. If you do not hear the click, continue rolling until the threader motor worm gear ( **4** in Figure A-7) stops. The LBA is in the correct position.

**Note:** Be sure to keep tension on the tape as the LBA is drawn into the cartridge by using a hex wrench as shown in Figure A-6 on page A-9.

8. Notice the:
  - a. Loader mechanism gear ( **6** in Figure A-7) nearest the front of the drive that actuates the cartridge loader mechanism.
  - b. Position of the rotate stub ( **3** in Figure A-7).
  - c. Front loader motor worm gear ( **1** in Figure A-7). Rotating this gear allows the loader mechanism gear ( **8** in Figure A-7) to turn.



9. Rotate the loader motor worm gear ( **1** in Figure A-7 on page A-10) to turn the threader mechanism gear ( **6** in Figure A-7 on page A-10) counterclockwise. Continue turning until the rotator stub ( **3** in Figure A-7 on page A-10) loses contact with the lever ( **7** in Figure A-7 on page A-10). This releases the LBA leader pin.
10. Rotate the threader motor worm gear ( **4** in Figure A-7 on page A-10) to turn the threader mechanism gear ( **6** in Figure A-7 on page A-10) counterclockwise. This moves the LBA out of the cartridge and past the read/write head. Stop this rotation when the LBA is near the tape guide roller nearest the rear of the drive shown as **1** Figure A-8.

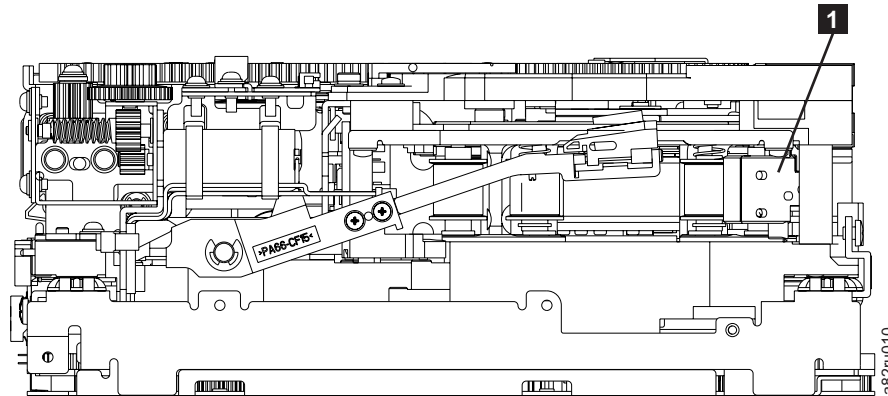

Figure A-8. Leader Block Assembly (LBA)

11. Continue rotating the loader motor worm gear ( **1** in Figure A-7 on page A-10) until the rotator stub ( **3** in Figure A-7 on page A-10) is positioned as shown. Notice that the rotator stub ( **3** in Figure A-7 on page A-10) is nearly aligned with the cartridge loader tray guide bearing ( **2** in Figure A-7 on page A-10).
12. Remove the cartridge from the cartridge loader tray.
13. Reassemble the drive by reversing the procedure in Step 4 on page A-4 in "Beginning Procedure" on page A-4.
14. Refer to the appropriate procedure to install the new drive and return the failed drive.

## No Apparent Failure or Damage to Tape

1. Set the drive on its left side with the head and tape path facing up.

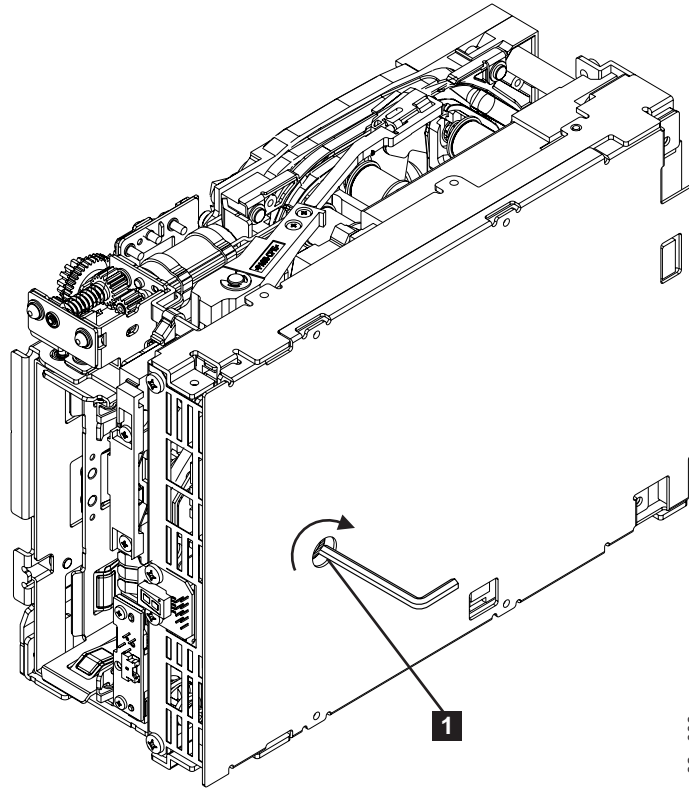
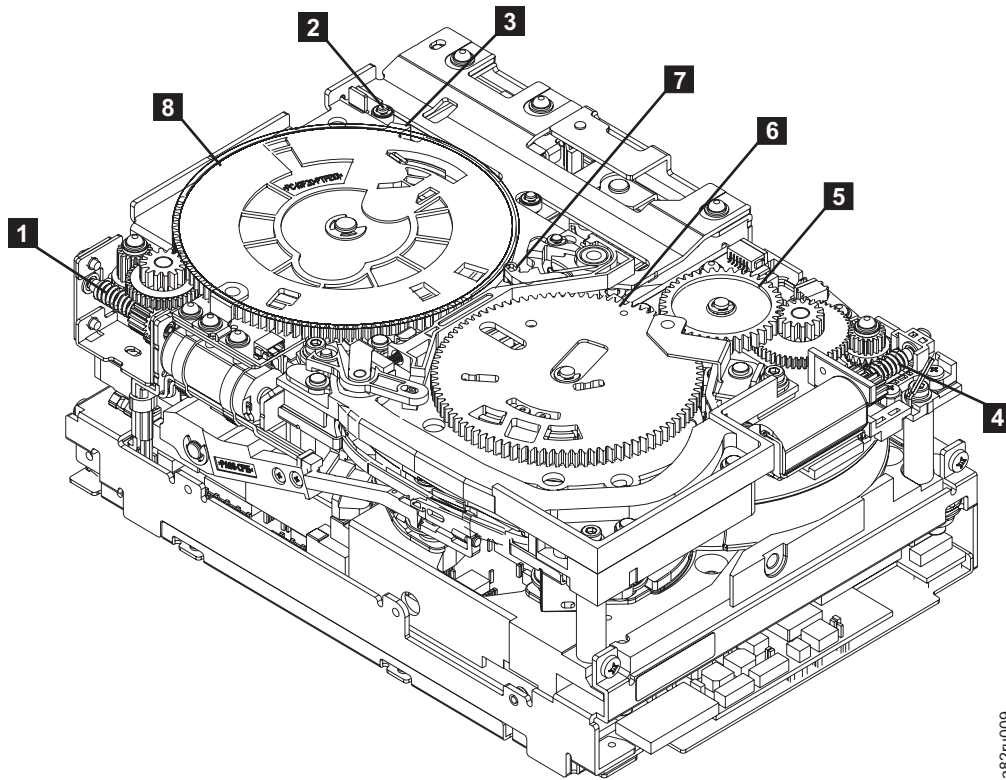

Figure A-9. Using hex wrench to rewind tape into cartridge

2. From the bottom of the drive, locate the access hole ( **1** in Figure A-9).
3. Insert a 2.5 mm offset hex wrench through the bottom cover access hole and into the reel motor axle. Begin spooling the tape back into the cartridge by turning the hex wrench clockwise.
4. Continue spooling into the cartridge until the tape is taut and remains within the flanges of the tape guiding rollers. Ensure that you do not stretch the tape.
5. Locate the threader motor worm gear ( **4** in Figure A-10 on page A-13) on the rear of the drive. Use your finger to rotate the threader motor worm gear and slowly rotate the threader mechanism gear ( **6** in Figure A-10 on page A-13) clockwise. This rotates the threader motor worm gear ( **4** in Figure A-10 on page A-13) clockwise, drawing the LBA into the cartridge.



a82ru009

Figure A-10. Drive with cover removed to reveal gear train.

- |          |                                     |          |                         |
|----------|-------------------------------------|----------|-------------------------|
| <b>1</b> | Loader motor worm gear              | <b>6</b> | Threader mechanism gear |
| <b>2</b> | Cartridge loader tray guide bearing | <b>7</b> | Lever                   |
| <b>3</b> | Rotator stub                        | <b>8</b> | Loader mechanism gear   |
| <b>4</b> | Threader motor worm gear            |          |                         |
| <b>5</b> | Threader intermediate gear          |          |                         |

6. As the tape leader block assembly (LBA) is secured in the cartridge, you should hear the LBA retention spring clips click into place. If you do not hear the click, continue rolling until the threader motor worm gear (**4** in Figure A-10) stops. The LBA is in the correct position.

**Note:** Be sure to keep tension on the tape as the LBA is drawn into the cartridge by using a hex wrench as shown in Figure A-9 on page A-12.

7. Notice the:
  - a. Loader mechanism gear (**6** in Figure A-10) nearest the front of the drive that actuates the cartridge loader mechanism.
  - b. Position of the rotate stub (**3** in Figure A-10).
  - c. Front loader motor worm gear (**1** in Figure A-10). Rotating this gear allows the loader mechanism gear (**8** in Figure A-10) to turn.
8. Rotate the loader motor worm gear (**1** in Figure A-10) to turn the loader mechanism gear (**6** in Figure A-10) counterclockwise. Continue turning until the rotator stub (**3** in Figure A-10) loses contact with the lever (**7** in Figure A-10). This releases the LBA leader pin.

9. Rotate the threader motor worm gear ( **4** in Figure A-10 on page A-13) to turn the threader mechanism gear ( **6** in Figure A-10 on page A-13) counterclockwise. This moves the LBA out of the cartridge and past the read/write head. Stop this rotation when the LBA is near the tape guide roller nearest the rear of the drive shown as **1** Figure A-11.

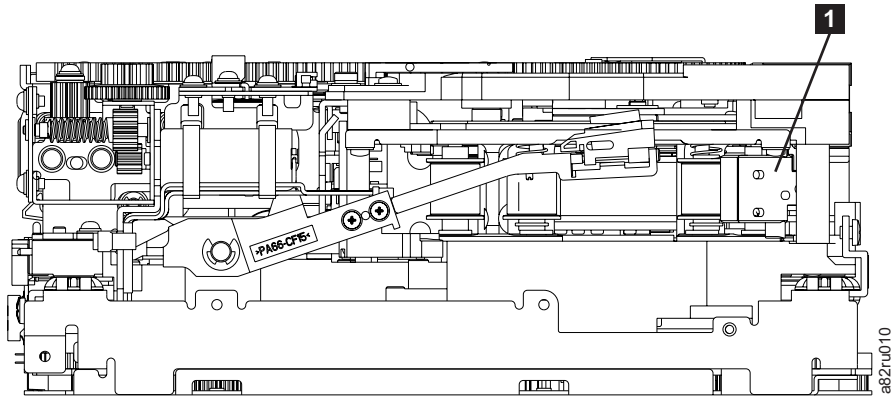

Figure A-11. Leader Block Assembly (LBA)

10. Continue rotating the loader motor worm gear ( **1** in Figure A-10 on page A-13) until the rotator stub ( **3** in Figure A-10 on page A-13) is positioned as shown. Notice that the rotator stub ( **3** in Figure A-10 on page A-13) is nearly aligned with the cartridge loader tray guide bearing ( **2** in Figure A-10 on page A-13).
11. Remove the cartridge from the cartridge loader tray.
12. Reassemble the drive by reversing the procedure in Step 4 on page A-4 in "Beginning Procedure" on page A-4.
13. Refer to the appropriate procedure to install the new drive and return the failed drive.

---

## Notices

### Trademarks

INSERT OEM TAPE DRIVE NAME HERE is a trademark of INSERT OEM COMPANY NAME HERE.

IBM is a trademark of International Business Machines corporation in the United States, or other countries or regions, or both.

The following terms are trademarks of International Business Machines Corporation in the United States, other countries (or regions), or both:

- AIX
- AS/400
- IBM
- IBMLink
- Linux
- OS/400
- System Storage

The following are U. S. trademarks of Hewlett-Packard Company, International Business Machines Corporation, and Seagate Technology.

- Linear Tape-Open
- LTO
- Ultrium Tape Drive

Microsoft is a registered trademark of Microsoft Corporation in the United States, or other countries (or regions), or both.

Solaris and Sun areSun is a registered trademarks of Sun Microsystems Incorporated.

Other company, product, and service names may be trademarks or service marks of others.

### Electronic Emission Notices

**Note:** This equipment has been tested and found to comply with the limits for a Class A digital device, pursuant to Part 15 of the FCC Rules. These limits are designed to provide reasonable protection against harmful interference when the equipment is operated in a commercial environment. This equipment generates, uses, and can radiate radio frequency energy and, if not installed and used in accordance with the instruction manual, may cause harmful interference to radio communications. Operation of this equipment in a residential area is likely to cause harmful interference, in which case the user will be required to correct the interference at his own expense.

Properly shielded and grounded cables and connectors must be used in order to meet FCC emission limits. IBM is not responsible for any radio or television interference caused by using other than recommended cables and connectors or by

unauthorized changes or modifications to this equipment. Unauthorized changes or modifications could void the user's authority to operate the equipment.

This device complies with Part 15 of the FCC Rules. Operation is subject to the following two conditions: (1) this device may not cause harmful interference, and (2) this device must accept any interference received, including interference that may cause undesired operation.

### **Industry Canada Class A Emission Compliance Statement**

This Class A digital apparatus complies with Canadian ICES-003.

### **Avis de conformité à la réglementation d'Industrie Canada**

Cet appareil numérique de la classe A est conforme à la norme NMB-003 du Canada.

### **European Union (EU) Electromagnetic Compatibility Directive**

This product is in conformity with the protection requirements of EU Council Directive 89/336/EEC on the approximation of the laws of the Member States relating to electromagnetic compatibility. IBM cannot accept responsibility for any failure to satisfy the protection requirements resulting from a non-recommended modification of the product, including the fitting of non-IBM option cards.

This product has been tested and found to comply with the limits for Class A Information Technology Equipment according to European Standard EN 55022. The limits for Class A equipment were derived for commercial and industrial environments to provide reasonable protection against interference with licensed communication equipment.

**Attention:** This is a Class A product. In a domestic environment this product may cause radio interference in which case the user may be required to take adequate measures.

Properly shielded and grounded cables and connectors must be used in order to reduce the potential for causing interference to radio and TV communications and to other electrical or electronic equipment. Such cables and connectors are available from IBM authorized dealers. IBM cannot accept responsibility for any interference caused by using other than recommended cables and connectors.

### **Germany Electromagnetic Compatibility Directive**

**Zulassungsbescheinigung laut dem Deutschen Gesetz über die elektromagnetische Verträglichkeit von Geräten (EMVG) vom 18. September 1998 (bzw. der EMC EG Richtlinie 89/336)**

Dieses Gerät ist berechtigt, in Übereinstimmung mit dem Deutschen EMVG das EG-Konformitätszeichen - CE - zu führen.

Verantwortlich für die Konformitätserklärung nach Paragraph 5 des EMVG ist die: IBM Deutschland Informationssysteme GmbH 70548 Stuttgart.

Informationen in Hinsicht EMVG Paragraph 4 Abs. (1) 4:

**Das Gerät erfüllt die Schutzanforderungen nach EN 55024 und EN 55022 Klasse A.**

EN 55022 Klasse A Geräte müssen mit folgendem Warnhinweis versehen werden:  
"Warnung: dies ist eine Einrichtung der Klasse A. Diese Einrichtung kann im Wohnbereich Funkstörungen verursachen; in diesem Fall kann vom Betreiber verlangt werden, angemessene Maßnahmen durchzuführen und dafür aufzukommen."

Anmerkung: Um die Einhaltung des EMVG sicherzustellen, sind die Geräte wie in den IBM Handbüchern angegeben zu installieren und zu betreiben.

**Japan VCCI Class A ITE Electronic Emission Statement**

この装置は、情報処理装置等電波障害自主規制協議会（VCCI）の基準に基づくクラスA情報技術装置です。この装置を家庭環境で使用すると電波妨害を引き起こすことがあります。この場合には使用者が適切な対策を講ずるよう要求されることがあります。

vcci

**People's Republic of China Class A Electronic Emission Statement**

中华人民共和国“A类”警告声明

声明

此为A级产品，在生活环境中，该产品可能会造成无线电干扰。在这种情况下，可能需要用户对其干扰采取切实可行的措施。

**Taiwan Class A Electronic Emission Statement**

警告使用者：  
這是甲類的資訊產品，在居住的環境中使用時，可能會造成射頻干擾，在這種情況下，使用者會被要求採取某些適當的對策。

taitemi

**Taiwan Class A Electronic Emission Statement**

台灣IBM 產品服務聯絡方式：  
台灣國際商業機器股份有限公司  
台北市松仁路7號3樓  
電話：0800-016-888

## Korean Class A Electronic Emission Statement

이 기기는 업무용으로 전자파 적합등록을 받은 기기  
이오니, 판매자 또는 사용자는 이점을 주의하시기  
바라며, 만약 잘못 구입하셨을 때에는 구입한 곳에  
서 비업무용으로 교환하시기 바랍니다.

### Getting Help

If you need assistance while installing or operating your IBM System Storage  
TS2340 Tape DriveINSERT OEM TAPE DRIVE NAME HERE, contact your OEM  
Product Application Engineer (PAE).

### Warranty

The warranty for this product is negotiated on a per-customer basis.



---

## Glossary

This glossary defines the special terms, abbreviations, and acronyms that are used in this publication.

### Numbers and Letters

#### 2:1 compression

The relationship between the quantity of data that can be stored with compression as compared to the quantity of data that can be stored without compression. In 2:1 compression, twice as much data can be stored with compression as can be stored without compression.

**µs** Abbreviation for microsecond or one millionth of a second (.000001 s).

### A

**A** See *ampere*.

#### acclimation time

Pertaining to the drive, the amount of time that is needed for the drive to adjust to change in temperature, altitude, climate, or environment.

**active** The condition that the SCSI bus is in when a server is trying to use one or more devices on the bus.

**ADI** Automation Drive Interface, a library interface protocol from the InterNational Committee for Information Technology Standards (INCITSSM) for T10 SCSI Storage Devices.

#### adapter

See *adapter card*.

#### adapter card

A circuit board that adds function to a computer.

#### AL\_PA

See *Arbitrated Loop Physical Address*.

**amp** See *ampere*.

#### ampere (A, amp)

A unit of measure for electric current that is equivalent to a flow of one coulomb per second, or equivalent to the current produced by one volt applied across a resistance of one ohm.

#### American National Standards Institute

A private, non-profit organization that gathers and disseminates information about standards and conformity issues that affect the business, government, and people of the United States.

**ANSI** See *American National Standards Institute*.

#### autosense data

Sent by the drive to the server, sense data that automatically accompanies a Check Condition in response to an error. The server does not need to send a REQUEST SENSE command to get the sense data. Autosense data is available only in the Fibre Channel version of the drive (Model T400F).

### B

**backhitch**

During tape movement (reading or writing), the condition that occurs when the tape drive must stop the tape, reverse it, and restart tape motion due to certain events. A backhitch usually occurs when the server's net (compressed) data rate is less than the drive's data rate.

**backreflection**

Pertaining to instances where light is launched into an optical fiber in a forward direction, the light that is returned to the launch point in the reverse direction.

**backups**

The short-term retention of records used for restoring essential business and server files when vital data has been lost because of program or server errors or malfunctions.

**backward compatible**

Capable of being used with a previous product that was designed for a similar purpose. For example, a tape cartridge that is designed to be used with a modern tape drive but can also be used with certain older tape drives. Synonymous with *downward compatible*.

**bar code**

A code that represents characters by sets of parallel bars of varying thickness and separation. The bars are read optically by transverse scanning.

**bar code label**

A slip of paper bearing a bar code and having an adhesive backing. The bar code label must be affixed to a tape cartridge to enable the library to identify the cartridge and its volume serial number.

**bezel** The removable frame that fits over the front of the drive.

**bit** The smallest unit of data in a computer. A bit (short for binary digit) has a single binary value (either 0 or 1). Computers store data and execute instructions in bit multiples called bytes. In most computer systems, there are eight bits in a byte.

**burst data transfer rate**

The maximum speed at which data is transferred.

**bus** See *SCSI bus*.

**byte** A string that consists of a certain number of bits (usually 8) which are treated as a unit and represent a character. A byte is a fundamental unit of data.

**C**

**C** See *Celsius*.

**capacity**

The amount of data that can be contained on storage media and expressed in bytes.

**cartridge**

See *tape cartridge*.

**cartridge door**

On a tape cartridge, the hinged barrier that can be opened to access, or closed to protect, the magnetic tape within the cartridge.

**cartridge manual rewind tool**

A device that can be fitted into the reel of a cartridge and used to rewind tape into or out of the cartridge.

**cartridge memory**

See *LTO cartridge memory*.

**Celsius**

Having a thermometric scale on which the interval between the freezing point and the boiling point of water is divided into 100 degrees, with 0° representing the freezing point and 100° representing the boiling point.

**channel calibration**

A feature of the drive by which it automatically customizes each read/write data channel to compensate for variations in such things as the recording channel's transfer function, the media, and characteristics of the drive head. Channel calibration optimizes system performance.

**circuit board**

A thin sheet on which chips and other electronic components are placed. Computers consist of one or more boards, often called cards or adapters.

**cleaning cartridge**

A tape cartridge that is used to clean the heads of a tape drive. Contrast with *data cartridge*.

**clockwise**

In the direction that the hands of a clock rotate, as viewed from the front.

**command time-out**

Following the issuance of a command, a period of time during which it is determined that there is a bad connection between the server and the drive.

**compression**

The process of eliminating gaps, empty fields, redundancies, and unnecessary data to shorten the length of records or blocks.

**configure**

To describe to a server the devices, optional features, and programs installed on the system.

**contiguous**

Touching along a boundary or at a point.

**core**

The light-conducting central portion of an optical fiber. The core is composed of material that has a higher index of refraction than the cladding (the material that surrounds the core).

**counterclockwise**

In a direction opposite to that in which the hands of a clock rotate, as viewed from the front.

**current**

The quantity of charge per unit of time. Current is measured in amperes.

**cycle power**

To apply and remove electrical power to a device within a short time span.

**D****data**

Any representations such as characters or analog quantities to which meaning is, or might be, assigned.

**data cartridge**

A tape cartridge that is dedicated to storing data. Contrast with *cleaning cartridge*.

**data compression**

See *compression*.

**data transfer rate**

The average number of bits, characters, or blocks per unit of time that pass between corresponding equipment in a data transmission system. The rate is expressed in bits, characters, or blocks per second, minute, or hour.

**dc** Direct current.

**degauss**

To make a magnetic tape nonmagnetic by exposing the tape to electrical coils which carry currents that neutralize the magnetism of the tape.

**device** Any hardware component or peripheral, such as a tape drive or tape library, that can receive and send data.

**device driver**

A file that contains the firmware that is needed to use an attached device.

**diagnostic**

A software program that is designed to recognize, locate, and explain faults in equipment or errors in programs.

**diagnostic cartridge**

A tape cartridge that enables the detection and isolation of errors in programs and faults in equipment.

**direct current (dc)**

An electric current flowing in one direction only and substantially constant in value.

**director-class switch**

A high-end switch that includes such qualities as fault tolerance, high throughput, high reliability, port density, and so forth.

**drive** See *IBM LTO Ultrium 4 Tape Drive*.

**drive dump**

The recording, at a particular instant, of the contents of all or part of one storage device into another storage device, usually as a safeguard against faults or errors, or in connection with debugging.

**drive head**

The component that records an electrical signal onto magnetic tape, or reads a signal from tape into an electrical signal.

**drive sense data**

See *SCSI drive sense data*.

**dump** See *drive dump*.

**duplex**

See *duplex transmission*.

**duplex adapter**

A mechanism that allows a device to send and receive communication at the same time.

**duplex transmission**

Transmission in both directions, either one direction at a time (half-duplex) or both directions simultaneously (full-duplex).

**E**

**eject** To remove or force out from within.

**electronic mail**

Correspondence in the form of messages transmitted between user terminals over a computer network.

**e-mail** See *electronic mail*.

**enclosure**

A device, such as a desktop unit, tape cartridge autoloader, or tape library, into which you can install the drive.

**encryption**

Encryption is a process that uses a coded encryption key to convert readable data strings to scrambled or cipher data. This encrypted data can only be read after the data is unscrambled, and this can only be accomplished if the reader has information about original encryption key. The IBM Tape Encryption solution uses a combination of symmetric encryption methods and asymmetric encryption methods.

**error log**

Maintained by the drive, a list that contains the ten most recent error codes. The codes identify errors that pertain to the drive.

**F****feature switch**

Located under the drive, a bank of eight micro switches that can be manually toggled on or off to activate or deactivate different characteristics of the drive.

**fiber optic cable**

The medium by which light is transmitted through fibers or thin rods of glass or some other transparent material of high refractive index.

**fiber optics**

A branch of optics dealing with the transmission of light through fibers or thin rods of glass or some other transparent material of high refractive index.

**field microcode replacement tape**

A tape cartridge that contains new or revised firmware (microcode) for the drive.

**file** A named set of records that are stored or processed as a unit.

**filemark**

Located on the magnetic tape within a tape cartridge, a recorded element that typically marks the organizational boundaries in a serial file structure (such as directory boundaries) and that is requested to be written or read by the server.

**firmware**

The proprietary code that is usually delivered as part of an operating system. Firmware is more efficient than software that is loaded from an alterable medium, and is more adaptable to change than pure hardware

circuitry. An example of firmware is the Basic Input/Output System (BIOS) in read-only memory (ROM) on a PC motherboard.

**FMR tape**

See *field microcode replacement tape*.

**foot** A unit of length comprising 12 inches.

**G**

**Gb** See *gigabit*.

**GB** See *gigabyte*.

**Generation 1**

The informal name for the IBM Ultrium Internal Tape Drive, which is the predecessor of the drive (Generation 2). The Generation 1 drive has a native storage capacity of up to 100 GB per cartridge and a native sustained data transfer rate of 15 MB per second.

**Generation2**

The informal name for the drive, which is the second-generation version of the IBM Ultrium Internal Tape Drive (Generation 1). The Generation 2 drive has a native storage capacity of up to 200 GB per cartridge and a native sustained data transfer rate of 35 MB per second.

**Generation 3**

The informal name for the drive, which is the third-generation version of the IBM Ultrium Internal Tape Drive (Generation 1). The Generation 3 drive has a native storage capacity of up to 400 GB per cartridge and a native sustained data transfer rate of 135 MB per second.

**gigabit (Gb)**

1 000 000 000 bits. 1 Gb equals 100 MB.

**gigabyte (GB)**

1 000 000 000 bytes.

**ground**

An object that makes an electrical connection with the earth.

**H**

**hard addressing**

Pertaining to the Fibre Channel drive (Model T400F), a method that identifies the drive's LID and, consequently, its AL\_PA (the AL\_PA enables the drive to communicate with other devices).

**hardware**

The physical equipment or devices that form a computer.

**head** See *drive head*.

**Head Resistance Measurements test**

Part of the Test Head diagnostic, a procedure that determines whether the tape drive's head works correctly. The test measures the head's ability to withstand cracks and other defects.

**host** The controlling or highest-level system in a data communication configuration. Synonymous with *server*.

**hot-pluggable**

Pertaining to the drive, the ability to remove the drive from an enclosure while the enclosure is powered-on.

**hub** A communications device to which nodes on a multi-point bus or loop are physically connected. Hubs are commonly used in Fibre Channel networks to improve the manageability of physical cables. They maintain the logical loop topology of the network of which they are a part, while creating a “hub and spoke” physical star layout. Unlike switches, hubs do not aggregate bandwidth. They typically support the addition or removal of nodes from the bus while it is operating.

## I

**ID** Identifier.

**in** See *inch*.

**inch** A unit of length equal to 1/36 yard or 25.4 mm.

### **initiator**

In SCSI terms, a SCSI device that requests an I/O process to be performed by another SCSI device (a target). In many cases, an initiator can also be a target.

### **input/output (I/O)**

Data that is provided to a computer or data that results from computer processing.

### **insertion guide**

On the surface of the IBM LTO Ultrium Tape Cartridge, a large, notched area that prevents you from inserting the cartridge incorrectly.

**install** To set up for use or service.

The act of adding a product, feature, or function to a server or device either by a singular change or by the addition of multiple components or devices.

### **Internet**

The worldwide collection of interconnected networks that use the Internet suite of protocols and permit public access.

### **interposer**

An adapter-like device that allows a connector of one size and style to connect to a mating connector of a different size and style. Data provided to the computer or data resulting from computer processing.

**I/O** See *input/output*.

## J

### **J2 connector**

Located at the rear of the drive, the connector for the LDI (or RS-422) interface.

### **J33 connector**

Located at the rear of the drive, a single connector that contains the connections for the SCSI signals and grounds, SCSI ID, SCSI bus termination, and drive power.

### **jumper**

A tiny connector that fits over a pair of protruding pins in a connector. A jumper can be moved to change electrical connectors. When in place, the jumper connects the pins electrically.

To place a jumper on a connector pin.

## L

**label** A slip of paper with an adhesive backing that can be written on and affixed to a tape cartridge as a means of identification or description.

**label area**

On the LTO Ultrium Tape Cartridge, a recessed area next to the write-protect switch where a bar code label must be affixed.

**LAN** See *local area network*.

**LDI** See *Library/Drive Interface*.

**LDI wrap plug**

A connector mechanism that connects to an LDI port for the purpose of testing the drive's circuitry for the LDI interface.

**LDI wrap test**

A diagnostic that can be run on the drive to determine whether the circuitry functions properly to and from the LDI connector.

**leader-pin block**

Located within the drive, the part that engages the steel pin which is attached to the tape in an LTO Ultrium Tape Cartridge. Once engaged, the leader-pin block pulls the tape from the cartridge into the drive.

**leader pin**

On the LTO Ultrium Tape Cartridge, a small metal column that is attached to the end of the magnetic tape. During tape processing the leader pin is grasped by a threading mechanism, which pulls the pin and the tape out of the cartridge, across the drive head, and onto a takeup reel. The head can then read or write data from or to the tape.

**LED** See *light-emitting diode*.

**Library/Drive Interface**

An electrical interface standard that is approved by the Electronic Industries Association (EIA) for connecting serial devices.

**Library/Drive Interface (LDI) connector**

Located at the rear of the drive, the connector to which the internal LDI cable of an enclosure connects. The connection enables serial devices to communicate with the drive.

**LID** See *loop identifier*.

**LID/status connector**

See *loop identifier (LID)/status connector*.

**link services**

The speed and topology of your Fibre Channel drive. If you choose not to alter the link services, the drive defaults to a negotiated speed and operation in an FC-AL topology with a direct connection to the server.

**LIP** See *loop initialization protocol*.

**light-emitting diode (LED)**

A semiconductor diode that emits light when subjected to an applied voltage and that is used in an electronic display.

**Linear Tape-Open (LTO)**

A type of tape storage technology developed by the IBM Corporation, Hewlett-Packard, and Seagate. LTO technology is an "open format" technology, which means that its users have multiple sources of product



and media. The “open” nature of LTO technology enables compatibility between different vendors’ offerings by ensuring that vendors comply with verification standards.

**load** Following the insertion of a tape cartridge into the tape load compartment, the act of positioning the tape (performed by the tape drive) for reading or writing by the drive’s head.

**load and unload cycle**

The act of inserting a cartridge into a tape drive, loading the tape to load point, rewinding the tape into the cartridge, and ejecting the cartridge from the drive.

**local area network (LAN)**

A computer network that is located on a user’s premises within a limited geographical area. The network consists of a set of devices that are connected to one another for communication and that can be connected to a larger network. Communications are limited to a moderate-sized geographic area (1 to 10 km) such as a single office building, warehouse, or campus.

**log sense data**

See *SCSI log sense data*.

**loop** A series of instructions that is repeated until a terminating condition is reached.

To connect so as to complete a loop.

**loss** In fiber optics technology, the amount of a signal’s power (expressed in dB) that is lost in connectors, splices, or fiber defects.

**Low Voltage Differential (LVD)**

A low-noise, low-power, and low-amplitude electrical signaling system that enables data communication between a supported server and the drive. LVD signaling uses two wires to drive one signal over copper wire. The use of wire pairs reduces electrical noise and crosstalk.

**LTO** See *Linear Tape-Open*.

**LTO cartridge memory (LTO-CM)**

Within each LTO Ultrium Data Cartridge, an embedded electronics and interface module that can store and retrieve a cartridge’s historical usage and other information.

**LTO-CM**

See *LTO cartridge memory*.

**LTO-DC**

See *LTO Data Compression*.

**LTO Data Compression (LTO-DC)**

A method that compresses a server’s data before the drive writes it to tape. LTO-DC detects but does not recompress or test record boundaries and file markers (which are encoded as control symbols). It also allows switching between compression and no compression within the data stream, which prevents data from expanding when the drive compresses random or encrypted data.

**LVD** See *Low Voltage Differential*.

**M**

**m** See *meter*.

**magnetic tape**

A tape with a magnetizable surface layer on which data can be stored by magnetic recording.

**maintenance mode**

The state of operation in which the drive must be before it can run diagnostics, verify write and read operations, verify a suspect tape cartridge, update its own firmware, and perform other diagnostic and maintenance functions.

**MB** See *megabyte*.

**media** The plural of *medium*.

**media capacity**

See *capacity*.

**medium**

A physical material in or on which data may be represented, such as magnetic tape.

**megabyte (MB)**

1 000 000 bytes.

**metal particle tape**

In the LTO Ultrium Tape Cartridge, tape that uses very small, pure metal particles (rather than oxide coatings) in the magnetic layer.

**meter** In the Metric System, the basic unit of length; equal to approximately 39.37 inches.

**micrometer**

One millionth of a meter (.000001 m). Synonymous with *micron*.  
Abbreviated as  $\mu\text{m}$ .

**micron**

One millionth of a meter (.000001 m). Synonymous with *micrometer*.  
Abbreviated as  $\mu\text{m}$ .

**microsecond**

One millionth of a second (.000001 s). Abbreviated as  $\mu\text{s}$ .

**millimeter (mm)**

One thousandth of a meter (.001 m).

**millisecond (ms)**

One thousandth of a second (.001 s).

**mm** See *millimeter*.

**Model T800**

The version of the IBM LTO Ultrium 4 Tape Drive that uses the SCSI interface.

**ms** See *millisecond*.

**multimode fiber**

An optical fiber that has a core that is large enough to propagate more than one electromagnetic wave of light. The typical diameter is 62.5 micrometers.

**N**

**N/A** Not applicable.

**native storage capacity**

The amount of data that can be stored without compression on a tape cartridge.

**native sustained data transfer rate**

See *data transfer rate*.

**negotiated speed**

Defined by Fibre Channel Standards, the algorithm that ensures the highest speed that is supported by both the drive and the port to which it attaches. This negotiation occurs at power up and whenever a catastrophic link event occurs, such as a cable pull that exceeds the timeouts that are specified in the Standards. The speed is negotiated when the first possibility of a new connection (for example, a fiber cable) is established, and is maintained until the Fibre Channel connection is terminated. The speed is not renegotiated when a new device is attached to a loop.

**network**

A configuration of data processing devices and software that is connected for information interchange.

**network server**

In a local area network, a personal computer that provides access to files for all of the workstations in the network.

**ntutil** Created by IBM, a utility program for LTO devices that connect to Windows NT® and Windows 2000. *ntutil* provides problem determination for hardware or connections, assists with device and medium changer recognition, forces dumps, loads new firmware, sends and receives SCSI commands to and from the hardware, and obtains SCSI sense data to use in resolving errors.

**NVRAM**

Non Volatile Random Access Memory.

**O****oersted**

The unit of magnetic field strength in the unrationalized centimeter-gram-second (cgs) electromagnetic system. The oersted is the magnetic field strength in the interior of an elongated, uniformly wound solenoid that is excited with a linear current density in its winding of one abampere per  $4\pi$  centimeters of axial length.

**offline**

The operating condition that the drive is in when the server's applications cannot interact with it.

**online** The operating condition that the drive is in when the server's applications can interact with it.

**Open Systems**

Computer systems whose standards are not proprietary.

**operating environment**

The temperature, relative humidity rate, and wet bulb temperature of the room in which the drive routinely conducts processing.

**operating system**

The master computer control program that translates the user's commands and allows software application programs to interact with the computer's hardware.

**optical transceiver**

A device that both transmits and receives analog or digital signals over a light source.

**P****panic reset**

The act of pressing and holding the Unload Button for 10 seconds to force a reset of a nonresponsive drive.

**parity** The state of being even-numbered or odd-numbered. A parity bit is a binary number that is added to a group of binary numbers to make the sum of that group always odd (odd parity) or even (even parity).

**parity error**

A transmission error that occurs when the received data does not have the parity that is expected by the receiving system. This usually occurs when the sending and receiving systems have different parity settings.

**point-to-point connection**

Pertaining to data transmission between two locations without the use of any intermediate display station or computer.

**port** A system or network access point for data entry or exit.

A connector on a device to which cables for other devices such as display stations and printers are attached.

The representation of a physical connection to hardware. A port is sometimes referred to as an adapter; however, there can be more than one port on an adapter.

**power connector**

Located at the rear of the drive, the connector to which the internal power cable of an enclosure connects.

**power cord**

A cable that connects a device to a source of electrical power.

**power-off**

To remove electrical power from a device.

**power-on, powered-on**

To apply electrical power to a device.

The state of a device when power has been applied to it.

**private device**

A device that is attached directly to a server and is not connected to a fabric or switch. A private device can be part of an arbitrated loop topology or point-to-point topology.

**protocol**

The meanings of, and the sequencing rules for, requests and responses that are used to manage a network, transfer data, and synchronize the states of network components.

**public device**

A device that is attached to a fabric or switch, and can communicate to that fabric or switch. A public device can be part of an arbitrated loop topology or point-to-point topology.

**Q**

**quiesce**

To put a device into a temporarily inactive or inhibited state, but not remove it from the server.

**R**

**read** To acquire or interpret data from a storage device, from a data medium, or from another source.

**reboot** To reinitialize the execution of a program by repeating the initial program load (IPL) operation.

**record** The smallest distinct set of data bytes that is supplied from a server for processing and recording by a tape drive, and the smallest distinct set of data to be read from tape, reprocessed, and made available to a server by a tape drive.

**record boundaries**

The fixed limits of a record.

**relative humidity**

The ratio of the amount of water vapor actually present in the air to the greatest amount possible at the same temperature.

**repeater**

A device that regenerates signals to extend the range of transmission between data stations or to interconnect two branches. A repeater is a node of a local area network.

**reset** To return a device or circuit to a clear state.

**S**

**s** See *second*.

**SAN** See *Storage Area Network*.

**SAN Data Gateway**

A device that provides Fibre Channel attachment between Open Systems servers and SCSI disk and tape storage systems.

**SAS** See *serial attached SCSI*

**SC** See *subscription channel connector*.

**scratch cartridge**

A data cartridge that contains no useful data, but can be written to with new data.

**SCSI** See *Small Computer Systems Interface*.

**SCSI bus**

A collection of wires through which data is transmitted from one part of a computer to another.

A generic term that refers to the complete set of signals that define the activity of the Small Computer Systems Interface (SCSI).

**SCSI connector**

Located at the rear of the drive, the connector that facilitates commands to and from the server, and to which the internal SCSI cable of an enclosure connects.

**SCSI device**

Anything that can connect into the SCSI bus and actively participate in bus activity.

**SCSI drive sense data**

In response to inquiry from the server about an error condition, a packet of SCSI sense bytes that contains information about the error and that is sent back to the server by the drive.

**SCSI ID**

The unique address (from 1 to 15) that you assign to an drive that uses a SCSI interface (Model T400).

**SCSI ID connector**

Located at the rear of the drive, the connector that enables the drive's SCSI address to be set. Addresses are determined by the placement of jumpers on the pins.

**SCSI interface**

See *Small Computer Systems Interface*.

**SCSI protocol**

A set of rules that control the communication and transfer of data between two or more SCSI devices or systems in a communications network.

**SCSI ID switch**

Located on an enclosure that contains a drive, a mechanism that connects to the drive and allows you to change the drive's SCSI ID without using jumpers.

**SCSI log sense data**

In response to inquiry from the server about the drive's error logs and counters, a packet of SCSI sense bytes which contains that information and which is sent back to the server by the drive. Log sense data is used to diagnose problems, especially if the problems are intermittent.

**SCSI wrap plug**

A connector mechanism that connects to a SCSI port for the purpose of testing the drive's circuitry for the SCSI interface.

**SCSI wrap test**

A diagnostic that can be run on the drive to determine whether the circuitry functions properly to and from the SCSI connector.

**second**

One sixtieth of a minute.

**selection time-out**

Following the selection of an option (for example, a data transfer), the period of time during which it is determined that there is a bad connection between the server and the drive.

**sense data**

Data that describes an I/O error. Sense data is presented to a server in response to a Sense I/O command.

**Serial Attached SCSI (SAS)**

SAS is a serial communication protocol.

**serial interface**

An interface that sequentially or consecutively executes two or more operations in a single device, such as an arithmetic and logic operation.

**server** A functional unit that provides services to one or more clients over a network. Examples include a file server, a print server, or a mail server. The IBM eServer pSeries, IBM eServer iSeries, HP, and Sun are servers. Synonymous with *host*.

**ship group**

The group of supplies, cords, or documentation that is shipped with the drive.

**shipping environment**

The temperature, relative humidity rate, and wet bulb temperature of the environment to which the drive is exposed when it is transferred from one location to another.

**short-wave cable**

In Fibre Channel technology, a laser cable that uses a wavelength of 780 nanometers and is only compatible with multimode fiber.

**single-character display**

Located at the front of the drive, an LED that presents an alphabetical or numeric code which represents a diagnostic or maintenance function, error condition, or informational message.

**sleep mode**

A power-management function that causes the drive's electronics to automatically enter a low-power mode by which to conserve energy.

**Small Computer Systems Interface (SCSI)**

A standard used by computer manufacturers for attaching peripheral devices (such as tape drives, hard disks, CD-ROM players, printers, and scanners) to computers (servers). Pronounced "scuzzy." Variations of the SCSI interface provide for faster data transmission rates than standard serial and parallel ports (up to 320 megabytes per second). The variations include:

- Fast/Wide SCSI: Uses a 16-bit bus, and supports data rates of up to 20 MBps.
- SCSI-1: Uses an 8-bit bus, and supports data rates of 4 MBps.
- SCSI-2: Same as SCSI-1, but uses a 50-pin connector instead of a 25-pin connector, and supports multiple devices.
- Ultra SCSI: Uses an 8- or 16-bit bus, and supports data rates of 20 or 40 MBps.
- Ultra2 SCSI: Uses an 8- or 16-bit bus and supports data rates of 40 or 80 MBps.
- Ultra3 SCSI: Uses a 16-bit bus and supports data rates of 80 or 160 MBps.
- Ultra160 SCSI: Uses a 16-bit bus and supports data rates of 160 MBps.
- Ultra320 SCSI: Uses a 16-bit bus and supports data rates of 320 MBps.

**soft addressing**

Pertaining to the Fibre Channel drive (Model T400F), a method that enables the drive to dynamically arbitrate its AL\_PA with other Fibre Channel devices on the loop. The AL\_PA enables the drive to communicate with other devices.

**software**

Programs, procedures, rules, and any associated documentation pertaining to the operation of a computer system.

**speed matching**

A technique used by the drive to dynamically adjust its native (uncompressed) data rate to the slower data rate of a server. Speed matching improves system performance and reduces backhitch.

**Status Light**

Located at the front of the drive, an LED that can be green or amber, and (when lit) solid or flashing. The condition of the light represents the state of the drive.

**Storage Area Network (SAN)**

A high-speed subnetwork of shared storage devices. A SAN's architecture makes all storage devices available to all servers on a LAN or WAN. As more storage devices are added to a SAN, they too will be accessible from any server in the larger network. Because stored data does not reside directly on any of a network's servers, server power is used for business applications, and network capacity is released to the end user.

**storage environment**

The temperature, relative humidity rate, and wet bulb temperature of the environment in which the drive is nonoperational and is being kept for future use.

**subscription channel connector (SC)**

A push-pull type of optical connector that features high density, low loss, low backreflection, and low cost.

**switch** A network infrastructure component to which multiple nodes attach. Unlike hubs, switches typically have the ability to switch node connections from one to another. A typical switch can facilitate several simultaneous bandwidth transmissions between different pairs of nodes.

**T**

**T10** T10 is a Technical Committee of the InterNational Committee on Information Technology Standards (INCITS). INCITS develops Information Processing System standards and is accredited by, and operates under rules that are approved by, the American National Standards Institute (ANSI).

**TapeAlert**

A patented technology and ANSI standard that defines conditions and problems that are experienced by tape drives.

**TapeAlert flags**

Status and error messages that are generated by the TapeAlert utility and display on the server's console.

**tape cartridge**

A removable storage case that houses belt-driven magnetic tape that is wound on a supply reel and a takeup reel.

**tape drive**

See *IBM LTO Ultrium 4 Tape Drive*.

**tape path**

Within a tape drive, the channel in which the media moves.

**tapeutil**

Created by IBM, a utility program for LTO devices that connect to all supported servers except Windows NT and Windows 2000. *tapeutil* provides service aids for tape subsystems, offers a menu-driven tool for exercising or testing IBM tape and medium changer devices, and includes a command-line interface that is convenient for use in shell scripts.

**terminate**

To prevent unwanted electrical signal reflections by applying a device (known as a terminator) that absorbs the energy from the transmission line.



**terminator**

A part that is used to end a SCSI bus.

A single-port, 75- $\Omega$  device that is used to absorb energy from a transmission line. Terminators prevent energy from reflecting back into a cable plant by absorbing the radio frequency signals. A terminator is usually shielded, which prevents unwanted signals from entering or valid signals from leaving the cable system.

**TERMPOWER**

Electrical power that is provided by a device (such as the drive) to a SCSI terminator so that the SCSI bus can function. To supply TERMPower, a jumper must be placed on pin 1 of the SCSI ID connector on the drive.

**Test Head diagnostic**

A test that determines whether the heads of the drive are operating properly and whether the drive can correctly read from and write to tape.

**throughput**

A measure of the amount of information that is transmitted over a network in a given period of time.

**topology**

In communications, the physical or logical arrangement of nodes in a network, especially the relationships among nodes and the links between them.

**track** A linear or angled pattern of data that is written on a tape surface.

**transfer rate**

See *data transfer rate*.

**U****Ultra160 LVD SCSI interface**

See *Small Computer Systems Interface*.

**uniform resource locator (URL)**

The address of an item on the World Wide Web. It includes the protocol followed by the fully qualified domain name (sometimes called the host name) and the request. The web server typically maps the request portion of the URL to a path and file name. For example, if the URL is `http://www.networking.ibm.com/nsg/nsgmain.htm`, the protocol is `http`; the fully qualified domain name is `www.networking.ibm.com`; and the request is `/nsg/nsgmain.htm`.

**unload**

The act (performed by the drive) of unthreading tape from the drive's internal tape path and returning it (with the leader block) to the tape cartridge.

**Unload Button**

Located at the front of the drive, a push button that, when depressed, rewinds the tape in a cartridge and ejects the cartridge from the drive. The Unload Button can also be used to place the tape drive in maintenance mode, scroll through maintenance functions, exit maintenance mode, force a drive dump, and reset the drive.

**URL** See *uniform resource locator*.

**utility** See *utility program*.

**utility program**

A computer program that supports computer processes. For example, a diagnostic program, a trace program, or a sort program.

**V**

**Vdc** Volts dc (direct current).

**vital product data (VPD)**

Information about a product. Among other details, the VPD may include a model number, serial number, part number, or level of firmware.

**volt** The SI (international) unit of potential difference and electromotive force. Formally defined as the difference of electric potential between two points of a conductor that carries a constant current of one ampere when the power dissipated between these points is equal to one watt.

**VPD** Vital product data.

**W**

**W** Watts.

**WAN** See *wide area network*.

**watt** The metric unit of power that is required to do work at the rate of one joule per second.

**web** See *World Wide Web*.

**wet bulb temperature**

The temperature at which pure water must be evaporated adiabatically at constant pressure into a given sample of air in order to saturate the air under steady-state conditions. Wet bulb temperature is read from a wet bulb thermometer.

**wide area network (WAN)**

A data communications network that is designed to serve an area of hundreds or thousands of miles (for example, national telephone networks).

**World Wide Web**

A network of servers that contain programs and files. Many of the files contain hypertext links to other documents that are available through the network.

**write** To make a permanent or transient recording of data in a storage device or on a data medium.

**write protected**

Applicable to a tape cartridge, the condition that exists when some logical or physical mechanism prevents a device from writing on the tape in that cartridge.

**write-protect switch**

Located on the LTO Ultrium Tape Cartridge, a switch that prevents accidental erasure of data. Pictures of a locked and unlocked padlock appear on the switch. When you slide the switch to the locked padlock, data cannot be written to the tape. When you slide the switch to the unlocked padlock, data can be written to the tape.

**Write/Read test**

Part of the Test Head diagnostic, a procedure that determines whether the drive can correctly read from and write to tape.

---

# Index

## A

- ac grounding diagram x
- Acclimation 4-8
- adjust data rate 1-5
- attaching tape drive to server 1-6

## B

- Bar code labels
  - ordering 4-19
- Bar Code Labels 4-4
  - guidelines for using 4-5

## C

- Capacity scaling 1-5
- cartridge
  - manual removal A-3
- Cartridge 4-1
  - capacity scaling 1-5, 4-1, 4-3
  - cleaning 4-4
  - compatibility 1-4, 4-2
  - data 4-1
  - disposal of 4-17
  - inserting 3-4
  - leader pin 4-10
  - memory chip 4-4
  - mid-tape recovery 3-5
  - ordering 4-18
  - proper handling 4-7
  - removing 3-5
  - specifications 4-16
  - Write-Protect Switch 4-6
- Cartridge acclimation 4-8
- Cartridges
  - testing 3-16
- Caution Notices ix
- channel calibration 1-5
- Configure drive
  - to hub 2-13
  - to server 2-13
  - to switch 2-13
- CRC 1-8
- customize each data channel 1-5
- Cyclic redundancy check (CRC) 1-8

## D

- Danger Notices ix
- Description of drive 1-1
- Device drivers
  - documentation 1-6
  - downloading from Web 1-6
  - installing 2-12
  - supported 1-6
- Diagnostics
  - clear error code log 3-15
  - copying drive dump to tape 3-11
  - disabling post error reporting 3-21

- Diagnostics (*continued*)
  - display error code log 3-15
  - enabling post error reporting 3-20
  - Fast Read/Write Test 3-19
  - forcing a drive dump 3-11
  - Load/Unload Test 3-20
  - RS-422 Wrap Test 3-14
  - running 2-12
  - SCSI Host Interface Wrap Test 3-12
  - selecting function 3-5
  - tape drive 3-8
  - test cartridge 3-16
  - Test Head 3-18
  - Write Performance Test 3-17
- Display
  - SCD dot 3-1
  - single-character 3-1
- Domain validation 1-8
- Double transition clocking 1-8
- Drive
  - description 1-1
  - features 1-1
  - fibre channel rear panel 1-3
  - front panel 1-2
  - SAS rear panel 1-4
  - SCSI rear panel 1-3
- Drive dump
  - copying to tape 3-11
  - forcing 3-11
  - obtaining 5-13
- Drive head
  - cleaning 3-5

## E

- Encryption 1-5
- Environmental conditions 4-8
- Environmental Notices ix
- environmental specifications 1-12
- Error code log
  - clear 3-15
  - display 3-15
- Error codes 5-2
  - receiving 5-2
- Error information
  - obtaining
    - from AS/400 5-10
    - from iSeries 5-10
    - from pSeries 5-10
    - from RS-6000 5-10
- Error log
  - viewing 5-14

## F

- Fast Read/Write Test 3-19
- Feature Switches 1-7
- Features of drive 1-1
- Fibre Channel attachment
  - requirements 1-6

- Fibre Channel interface
  - address assignments 1-10
  - attachment 1-8
  - change link services 2-9
  - external server connection 2-13
  - installing drive 1-10
  - internal cable connection 2-12
  - laser 1-8
  - physical characteristics 1-9
  - removing drive 1-10
  - resetting drive 1-10
  - setting AL\_PA 2-4
  - setting Loop ID 2-2
  - speed 1-10
  - supported topologies 1-9
  - world wide names 1-10
- Firmware
  - updating 3-21
    - using Fibre Channel interface 3-22
    - using FMR tape 3-23
    - using ITDT Tool 3-22
    - using LDI 3-22
    - using SCSI interface 3-22
- FMR tape
  - create 3-10
  - unmake 3-14
  - update firmware 3-9

## G

- grounding diagram x

## I

- Insert Cartridge 3-16
- installation 2-1
- Installation 2-1

## J

- jumpers 2-3

## L

- Labels
  - bar code 4-4
  - guidelines for using 4-5
  - ordering 4-19
- LDI
  - internal cable connection 2-12
- LDI interface 2-3
- Library interface 1-7
- library protocol 2-10
- Load/Unload Test 3-20

## M

- Maintenance
  - create FMR tape 3-10
  - update firmware with FMR tape 3-9
- Maintenance Function
  - selecting function 3-5
  - unmaking an FMR tape 3-14
- Maintenance Mode
  - entering 3-7
  - exiting 3-7, 3-8
- manual removal of tape cartridge A-3
- Media 4-1
  - capacity scaling 1-5
  - cartridge compatibility 1-4
  - inserting 3-4
  - mid-tape recovery 3-5
  - removing 3-5
  - resolving problems 5-19
- Message codes 5-2
  - receiving 5-2
- Mounting into enclosure 2-10

## O

- Operating systems supported 1-6
- operating systems, supported 1-6

## P

- Parts list 6-1
- physical specifications 1-11
- Post error reporting
  - disabling 3-21
  - enabling 3-20
- Power
  - connect to drive 2-11
  - test to drive 2-11
- power specifications 1-11
- Problems reported by server
  - resolving 5-14
  - SCSI bus errors 5-15
- protocol for library interface 2-10

## R

- Rack safety xi
- Read/Write capability 4-2
- Related Publications xv
- requirements for attaching tape drive to server 1-6
- RS-422 Wrap Test 3-14

## S

- Safety inspection procedure x
- Safety Notices ix
- SAS interface 1-11
  - internal cable connection 2-12
  - physical characteristics 1-11
- SCSI attachment
  - requirements 1-6
- SCSI Host Interface Wrap Test 3-12
- SCSI ID 1-8
  - setting 2-2
  - with jumpers 2-3

- SCSI ID (*continued*)
  - setting (*continued*)
    - with LDI interface 2-3
    - with SCSI ID switch 2-3
  - switch 2-3
- SCSI interface 1-7
  - address assignments 1-8
  - external server connection 2-13
  - ID 1-8
  - installing drive 1-8
  - internal cable connection 2-12
  - physical characteristics 1-8
  - removing drive 1-8
  - resetting drive 1-8
  - setting ID 2-2
    - with jumpers 2-3
    - with LDI interface 2-3
    - with SCSI ID switch 2-3
  - speed
    - cyclic redundancy check 1-8
    - domain validation 1-8
    - double transition clocking 1-8
- Sense data
  - using 5-9
- server connection
  - external Fibre Channel 2-13
  - external SCSI 2-13
- Servers supported 1-6
- servers, supported 1-6
- Service procedures A-1
  - SAS drive
    - removing from enclosure A-2
  - SCSI drive
    - removing from enclosure A-1
- Specifications
  - cartridges 4-16
  - environmental 1-11
  - physical 1-11
  - power 1-11
  - speed matching 1-5
- Status Light 3-1
- Support Notification ix
- supported SAN components 1-6
- supported servers and operating systems 1-6
- Switches, feature 1-7

## T

- Technical Support
  - accessing online ix
  - Support Notification ix
- TERMPower 2-4
- Test Drive Head 3-18
- Troubleshooting 5-1

## U

- Unload Button 3-3
- Unpacking shipment 2-1
- Updating firmware 3-21
  - using Fibre Channel interface 3-22
  - using FMR tape 3-23
  - using ITDT Tool 3-22
  - using LDI 3-22
  - using SCSI interface 3-22

- using ITDT test tool
  - drive dump 5-13

## W

- Windows NT
  - requirements for attaching tape drive to 1-6
- WORM (Write Once, Read Many) 4-3
- Write Once, Read Many (see WORM) 4-3
- Write Performance Test 3-17
- Write-Protect Switch
  - setting 4-6

---

## Readers' Comments — We'd Like to Hear from You

IBM LTO Ultrium 4 Tape Drive  
Setup, Operator, and Service Guide  
Model T1600P

Publication No. GC27-2102-01

We appreciate your comments about this publication. Please comment on specific errors or omissions, accuracy, organization, subject matter, or completeness of this book. The comments you send should pertain to only the information in this manual or product and the way in which the information is presented.

For technical questions and information about products and prices, please contact your IBM branch office, your IBM business partner, or your authorized remarketer.

When you send comments to IBM, you grant IBM a nonexclusive right to use or distribute your comments in any way it believes appropriate without incurring any obligation to you. IBM or any other organizations will only use the personal information that you supply to contact you about the issues that you state on this form.

Comments:

Thank you for your support.

Submit your comments using one of these channels:

- Send your comments to the address on the reverse side of this form.

If you would like a response from IBM, please fill in the following information:

\_\_\_\_\_

Name

\_\_\_\_\_

Address

\_\_\_\_\_

Company or Organization

\_\_\_\_\_

Phone No.

\_\_\_\_\_

E-mail address



Fold and Tape

Please do not staple

Fold and Tape



NO POSTAGE  
NECESSARY  
IF MAILED IN THE  
UNITED STATES

# BUSINESS REPLY MAIL

FIRST-CLASS MAIL PERMIT NO. 40 ARMONK, NEW YORK

POSTAGE WILL BE PAID BY ADDRESSEE

International Business Machines Corporation  
Information Development  
Department GZW  
9000 South Rita Road  
Tucson, Arizona U.S.A. 85775-4401

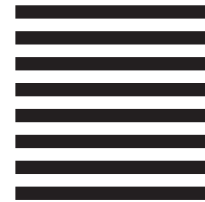

Fold and Tape

Please do not staple

Fold and Tape





Printed in USA

GC27-2102-01





Spine information:



IBM LTO Ultrium 4 Tape Drive

Model T1600P

Model T1600P