

## Overview of CMA and Rail Kit Hardware Fasteners



This guide describes cable management arm (CMA) and rail kit hardware fasteners used for securing high-density Model 106 chassis and rails to rack posts.

This quick start overview supplements the detailed procedures in the *Hardware Installation and Maintenance Guide* for your enclosure product.

## Package Contents

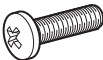

### CMA Kit - Package Contents

Table 1. CMA Kit - Package Contents

Item		Quantity	Description
1		6	Screw, M4x4 L, Pan head
2		4	Velcro strip, CMA routing

### Rail Kit Fasteners - Package Contents

Table 2. Rail Kit Fasteners - Package Contents

Item		Quantity	Description
1		4	Cage nut, 10-32, STL
2		10	Screw, 10-32x3/4, Truss, PLP, SS
3		2	Screw, M5x4, Pan head

## CMA Kit Instructions

1. Attach bracket from rail kit to rail with four screws (Item 1 under Table 1) M4x4 PH. Torque: 12 lbf-in.

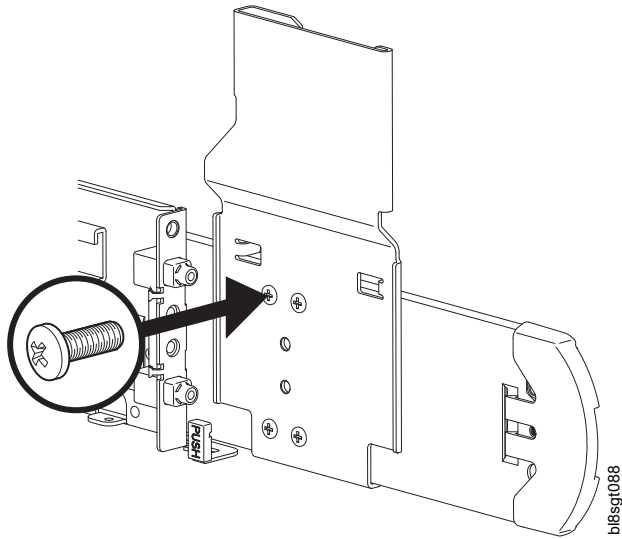

2. Attach 'C' bracket from rail kit to chassis with two screws (Item 1 under Table 1 on page 1) M4x4 PH. Torque: 12 lbf-in.

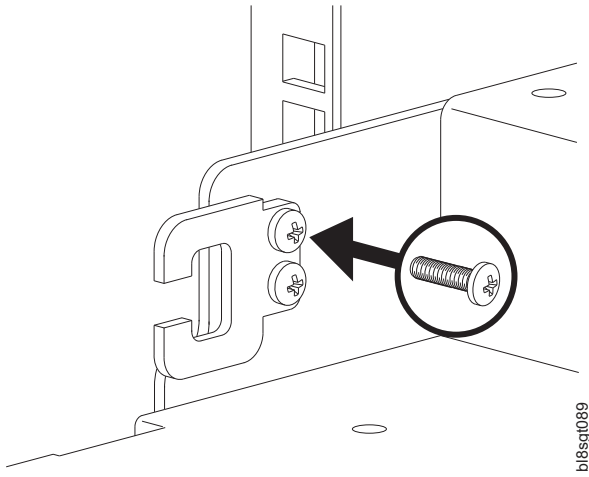

3. The Velcro strips (Item 2 under Table 1 on page 1) secure the CMA bundle where needed. See the *CMA cable routing instructions* topic in the *Hardware Installation and Maintenance Guide*.

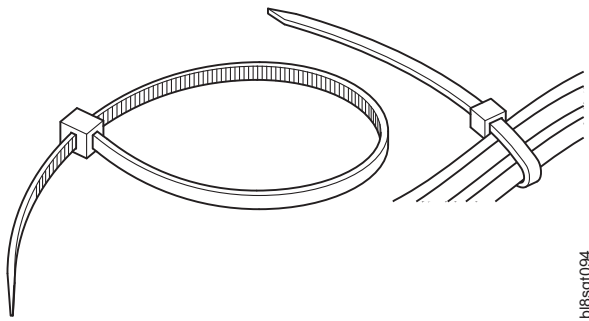

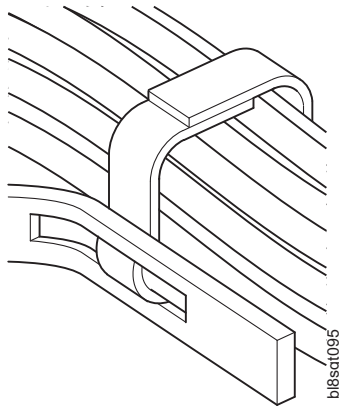

## Rail Kit Hardware Fastener Instructions

1. Insert four cage nuts (Item 1 under Table 2 on page 1) into rack at 4U spacing.

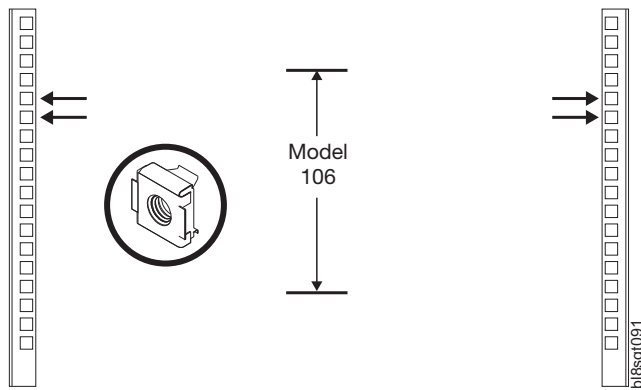

2. Use ten screws (Item 2 under Table 2 on page 1) to attach left and right rails to rack. Torque: 27 lbf-in.

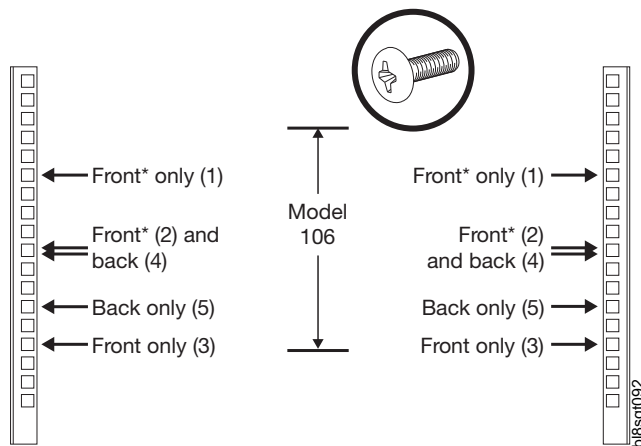

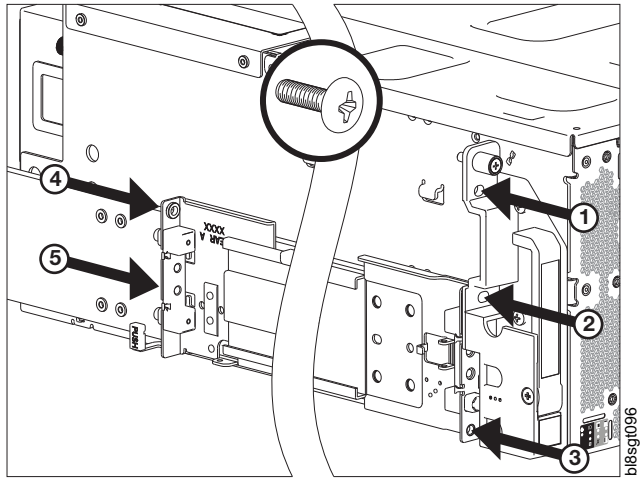

The (\*) screws in the rack-post diagram above are used for shipping and transport only. Each chassis thumbscrew and lower front rail screw secure the handle to the rack post. For more information, see the enclosure installation instructions in the *Hardware Installation and Maintenance Guide - Model 106*.

3. (Optional) Use two screws (Item 3 under Table 2 on page 1).

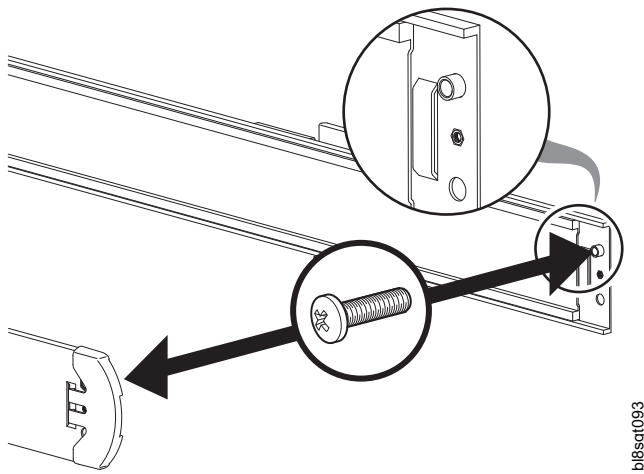

**Note:** This step is required for preventing non-operating transportation shock and vibration.

---

© **Copyright IBM Corporation 2018.**

US Government Users Restricted Rights – Use, duplication or disclosure restricted by GSA ADP Schedule Contract with IBM Corp.

SC27-9296-00

