

IBM Storwize V7000 Unified

*Model 2073-720 Quick Installation
Guide*



Note

Before using this information and the product it supports, read the following information:

- The general information in “Notices” on page 91
- The information in the “Safety and environmental notices” on page iii
- The information in the *IBM Environmental Notices and User Guide* (provided on a DVD)

This edition applies to IBM Storwize V7000 Unified and to all subsequent releases and modifications until otherwise indicated in new editions.

© Copyright IBM Corporation 2013, 2016.

US Government Users Restricted Rights – Use, duplication or disclosure restricted by GSA ADP Schedule Contract with IBM Corp.

Safety and environmental notices

Review the safety notices, environmental notices, and electronic emission notices for IBM® Storwize® V7000 Unified before you install and use the product.

Suitability for telecommunication environment: This product is not intended to connect directly or indirectly by any means whatsoever to interfaces of public telecommunications networks.

Here are examples of a caution and a danger notice:

CAUTION:

A caution notice indicates the presence of a hazard that has the potential of causing moderate or minor personal injury. (C001)

DANGER

<p>A danger notice indicates the presence of a hazard that has the potential of causing death or serious personal injury. (D002)</p>

To find the translated text for a caution or danger notice:

1. Look for the identification number at the end of each caution notice or each danger notice. In the preceding examples, the numbers (C001) and (D002) are the identification numbers.
2. Locate the *IBM Systems Safety Notices* with the user publications that were provided with the Storwize V7000 Unified hardware.
3. Find the matching identification number in the *IBM Systems Safety Notices*. Then, review the topics concerning the safety notices to ensure that you are in compliance.
4. Optionally, read the multilingual safety instructions on the Storwize V7000 Unified website. Go to www.ibm.com/storage/support/storwize/v7000/unified, search for Storwize V7000 Unified, and click the documentation link.

Safety notices and labels

Review the safety notices and safety information labels before using this product.

To view a PDF file, you need Adobe Acrobat Reader. You can download it at no charge from the Adobe website:

www.adobe.com/support/downloads/main.html

IBM Systems Safety Notices

This publication contains the safety notices for the IBM Systems products in English and other languages. Anyone who plans, installs, operates, or services the system must be familiar with and understand the safety notices. Read the related safety notices before you begin work.

Note: The *IBM System Safety Notices* document is organized into two sections. The danger and caution notices without labels are organized alphabetically by language

in the “Danger and caution notices by language” section. The danger and caution notices that are accompanied with a label are organized by label reference number in the “Labels” section.

Note: You can find and download the current *IBM System Safety Notices* by searching for Publication number **G229-9054** in the IBM Publications Center.

The following notices and statements are used in IBM documents. They are listed in order of decreasing severity of potential hazards.

Danger notice definition

A special note that emphasizes a situation that is potentially lethal or extremely hazardous to people.

Caution notice definition

A special note that emphasizes a situation that is potentially hazardous to people because of some existing condition, or to a potentially dangerous situation that might develop because of some unsafe practice.

Note: In addition to these notices, labels might be attached to the product to warn of potential hazards.

Finding translated notices

Each safety notice contains an identification number. You can use this identification number to check the safety notice in each language.

To find the translated text for a caution or danger notice:

1. In the product documentation, look for the identification number at the end of each caution notice or each danger notice. In the following examples, the numbers (D002) and (C001) are the identification numbers.

DANGER

A danger notice indicates the presence of a hazard that has the potential of causing death or serious personal injury. (D002)

CAUTION:

A caution notice indicates the presence of a hazard that has the potential of causing moderate or minor personal injury. (C001)

2. After you download the *IBM System Safety Notices* document, open it.
3. Under the language, find the matching identification number. Review the topics about the safety notices to ensure that you are in compliance.

Note: This product was designed, tested, and manufactured to comply with IEC 60950-1, and where required, to relevant national standards that are based on IEC 60950-1.

Caution notices for the Storwize V7000 Unified

Ensure that you understand the caution notices for Storwize V7000 Unified.

Use the reference numbers in parentheses at the end of each notice, such as (C003) for example, to find the matching translated notice in *IBM Systems Safety Notices*.

CAUTION:

The battery contains lithium. To avoid possible explosion, do not burn or charge the battery.

Do not: Throw or immerse into water, heat to more than 100°C (212°F), repair or disassemble. (C003)

CAUTION:

Electrical current from power, telephone, and communication cables can be hazardous. To avoid personal injury or equipment damage, disconnect the attached power cords, telecommunication systems, networks, and modems before you open the machine covers, unless instructed otherwise in the installation and configuration procedures. (26)

CAUTION:

- Do not install a unit in a rack where the internal rack ambient temperatures will exceed the manufacturer's recommended ambient temperature for all your rack-mounted devices.
- Do not install a unit in a rack where the air flow is compromised. Ensure that air flow is not blocked or reduced on any side, front, or back of a unit used for air flow through the unit.
- Consideration should be given to the connection of the equipment to the supply circuit so that overloading of the circuits does not compromise the supply wiring or overcurrent protection. To provide the correct power connection to a rack, refer to the rating labels located on the equipment in the rack to determine the total power requirement of the supply circuit.
- (For sliding drawers) Do not pull out or install any drawer or feature if the rack stabilizer brackets are not attached to the rack. Do not pull out more than one drawer at a time. The rack might become unstable if you pull out more than one drawer at a time.
- (For fixed drawers) This drawer is a fixed drawer and must not be moved for servicing unless specified by the manufacturer. Attempting to move the drawer partially or completely out of the rack might cause the rack to become unstable or cause the drawer to fall out of the rack.

(R001 part 2 of 2)

CAUTION:

Removing components from the upper positions in the rack cabinet improves rack stability during a relocation. Follow these general guidelines whenever you relocate a populated rack cabinet within a room or building.

- Reduce the weight of the rack cabinet by removing equipment starting at the top of the rack cabinet. When possible, restore the rack cabinet to the configuration of the rack cabinet as you received it. If this configuration is not known, you must observe the following precautions.
 - Remove all devices in the 32U position and above.
 - Ensure that the heaviest devices are installed in the bottom of the rack cabinet.
 - Ensure that there are no empty U-levels between devices installed in the rack cabinet below the 32U level.
- If the rack cabinet you are relocating is part of a suite of rack cabinets, detach the rack cabinet from the suite.
- If the rack cabinet you are relocating was supplied with removable outriggers they must be reinstalled before the cabinet is relocated.
- Inspect the route that you plan to take to eliminate potential hazards.
- Verify that the route that you choose can support the weight of the loaded rack cabinet. Refer to the documentation that comes with your rack cabinet for the weight of a loaded rack cabinet.
- Verify that all door openings are at least 760 x 230 mm (30 x 80 in.).
- Ensure that all devices, shelves, drawers, doors, and cables are secure.
- Ensure that the four leveling pads are raised to their highest position.
- Ensure that there is no stabilizer bracket installed on the rack cabinet during movement.
- Do not use a ramp inclined at more than 10 degrees.
- When the rack cabinet is in the new location, complete the following steps:
 - Lower the four leveling pads.
 - Install stabilizer brackets on the rack cabinet.
 - If you removed any devices from the rack cabinet, repopulate the rack cabinet from the lowest position to the highest position.
- If a long-distance relocation is required, restore the rack cabinet to the configuration of the rack cabinet as you received it. Pack the rack cabinet in the original packaging material, or equivalent. Also lower the leveling pads to raise the casters off the pallet and bolt the rack cabinet to the pallet.

(R002)

CAUTION:

- Rack is not intended to serve as an enclosure and does not provide any degrees of protection required of enclosures.
- It is intended that equipment installed within this rack will have its own enclosure. (R005).

CAUTION:

Tighten the stabilizer brackets until they are flush against the rack. (R006)

CAUTION:

Use safe practices when lifting. (R007)

CAUTION:

Do not place any object on top of a rack-mounted device unless that rack-mounted device is intended for use as a shelf. (R008)

CAUTION:

If the rack is designed to be coupled to another rack only the same model rack should be coupled together with another same model rack. (R009)

Danger notices for Storwize V7000 Unified

Ensure that you are familiar with the danger notices for Storwize V7000 Unified.

Use the reference numbers in parentheses at the end of each notice, such as (C003) for example, to find the matching translated notice in *IBM Systems Safety Notices*.

DANGER

When working on or around the system, observe the following precautions:

Electrical voltage and current from power, telephone, and communication cables are hazardous. To avoid a shock hazard:

- If IBM supplied a power cord(s), connect power to this unit only with the IBM provided power cord. Do not use the IBM provided power cord for any other product.
- Do not open or service any power supply assembly.
- Do not connect or disconnect any cables or perform installation, maintenance, or reconfiguration of this product during an electrical storm.
- The product might be equipped with multiple power cords. To remove all hazardous voltages, disconnect all power cords.
- Connect all power cords to a properly wired and grounded electrical outlet. Ensure that the outlet supplies proper voltage and phase rotation according to the system rating plate.
- Connect any equipment that will be attached to this product to properly wired outlets.
- When possible, use one hand only to connect or disconnect signal cables.
- Never turn on any equipment when there is evidence of fire, water, or structural damage.
- Disconnect the attached power cords, telecommunications systems, networks, and modems before you open the device covers, unless instructed otherwise in the installation and configuration procedures.
- Connect and disconnect cables as described in the following procedures when installing, moving, or opening covers on this product or attached devices.

To disconnect:

1. Turn off everything (unless instructed otherwise).
2. Remove the power cords from the outlets.
3. Remove the signal cables from the connectors.
4. Remove all cables from the devices.

To connect:

1. Turn off everything (unless instructed otherwise).
 2. Attach all cables to the devices.
 3. Attach the signal cables to the connectors.
 4. Attach the power cords to the outlets.
 5. Turn on the devices.
- Sharp edges, corners and joints might be present in and around the system. Use care when handling equipment to avoid cuts, scrapes and pinching. (D005)

DANGER

Heavy equipment—personal injury or equipment damage might result if mishandled. (D006)

DANGER

Observe the following precautions when working on or around your IT rack system:

- Heavy equipment—personal injury or equipment damage might result if mishandled.
- Always lower the leveling pads on the rack cabinet.
- Always install stabilizer brackets on the rack cabinet.
- To avoid hazardous conditions due to uneven mechanical loading, always install the heaviest devices in the bottom of the rack cabinet. Always install servers and optional devices starting from the bottom of the rack cabinet.
- Rack-mounted devices are not to be used as shelves or work spaces. Do not place objects on top of rack-mounted devices.



- Each rack cabinet might have more than one power cord. Be sure to disconnect all power cords in the rack cabinet when directed to disconnect power during servicing.
- Connect all devices installed in a rack cabinet to power devices installed in the same rack cabinet. Do not plug a power cord from a device installed in one rack cabinet into a power device installed in a different rack cabinet.
- An electrical outlet that is not correctly wired could place hazardous voltage on the metal parts of the system or the devices that attach to the system. It is the responsibility of the customer to ensure that the outlet is correctly wired and grounded to prevent an electrical shock.

(R001 part 1 of 2)

DANGER

Racks with a total weight of > 227 kg (500 lb.), Use Only Professional Movers! (R003)

DANGER

Do not transport the rack via fork truck unless it is properly packaged, secured on top of the supplied pallet. (R004)

DANGER



Main Protective Earth (Ground):

This symbol is marked on the frame of the rack.

The PROTECTIVE EARTHING CONDUCTORS should be terminated at that point. A recognized or certified closed loop connector (ring terminal) should be used and secured to the frame with a lock washer using a bolt or stud. The connector should be properly sized to be suitable for the bolt or stud, the locking washer, the rating for the conducting wire used, and the considered rating of the breaker. The intent is to ensure the frame is electrically bonded to the PROTECTIVE EARTHING CONDUCTORS. The hole that the bolt or stud goes into where the terminal conductor and the lock washer contact should be free of any non-conductive material to allow for metal to metal contact. All PROTECTIVE EARTHING CONDUCTORS should terminate at this main protective earthing terminal or at points marked with  . (R010)

Special caution and safety notices

This information describes special safety notices that apply to the Storwize V7000 Unified. These notices are in addition to the standard safety notices supplied and address specific issues relevant to the equipment provided.

General safety

When you service the Storwize V7000 Unified, follow general safety guidelines.

Use the following general rules to ensure safety to yourself and others.

- Observe good housekeeping in the area where the devices are kept during and after maintenance.
- Follow the guidelines when lifting any heavy object:
 1. Ensure that you can stand safely without slipping.
 2. Distribute the weight of the object equally between your feet.
 3. Use a slow lifting force. Never move suddenly or twist when you attempt to lift.
 4. Lift by standing or by pushing up with your leg muscles; this action removes the strain from the muscles in your back. *Do not attempt to lift any objects that weigh more than 18 kg (40 lb) or objects that you think are too heavy for you.*
- Do not perform any action that causes a hazard or makes the equipment unsafe.
- Before you start the device, ensure that other personnel are not in a hazardous position.
- Place removed covers and other parts in a safe place, away from all personnel, while you are servicing the unit.
- Keep your tool case away from walk areas so that other people cannot trip over it.
- Do not wear loose clothing that can be trapped in the moving parts of a device. Ensure that your sleeves are fastened or rolled up above your elbows. If your hair is long, fasten it.

- Insert the ends of your necktie or scarf inside clothing or fasten it with a nonconducting clip, approximately 8 cm (3 in.) from the end.
- Do not wear jewelry, chains, metal-frame eyeglasses, or metal fasteners for your clothing.

Remember: Metal objects are good electrical conductors.

- Wear safety glasses when you are hammering, drilling, soldering, cutting wire, attaching springs, using solvents, or working in any other conditions that might be hazardous to your eyes.
- After service, reinstall all safety shields, guards, labels, and ground wires. Replace any safety device that is worn or defective.
- Reinstall all covers correctly after you have finished servicing the unit.

Handling static-sensitive devices

Ensure that you understand how to handle devices that are sensitive to static electricity.

Attention: Static electricity can damage electronic devices and your system. To avoid damage, keep static-sensitive devices in their static-protective bags until you are ready to install them.

To reduce the possibility of electrostatic discharge, observe the following precautions:

- Limit your movement. Movement can cause static electricity to build up around you.
- Handle the device carefully, holding it by its edges or frame.
- Do not touch solder joints, pins, or exposed printed circuitry.
- Do not leave the device where others can handle and possibly damage the device.
- While the device is still in its antistatic bag, touch it to an unpainted metal part of the system unit for at least two seconds. (This action removes static electricity from the package and from your body.)
- Remove the device from its package and install it directly into your Storwize V7000 Unified, without putting it down. If it is necessary to put the device down, place it onto its static-protective bag. (If your device is an adapter, place it component-side up.) Do not place the device onto the cover of the Storwize V7000 Unified or onto a metal table.
- Take additional care when you handle devices during cold weather. Indoor humidity tends to decrease in cold weather, causing an increase in static electricity.

Sound pressure

Attention: Depending on local conditions, the sound pressure can exceed 85 dB(A) during service operations. In such cases, wear appropriate hearing protection.

Environmental notices

This information contains all of the required environmental notices for IBM Systems products in English and other languages.

The *IBM Systems Environmental Notices* (<http://ibm.co/1fBgWFI>) information includes statements on limitations, product information, product recycling and disposal, battery information, flat panel display, refrigeration and water-cooling systems, external power supplies, and safety data sheets.

About this guide

This publication provides information that helps you install and initialize IBM Storwize V7000 Unified systems.

Who should use this guide

This guide is intended for installers of Storwize V7000 Unified systems.

Before configuring your system, ensure that you follow the procedures as listed. Be sure to gather IP addresses that you will need before you begin the installation.

Storwize V7000 Unified library and related publications

Product manuals, other publications, and websites contain information that relates to Storwize V7000 Unified.

IBM Knowledge Center for Storwize V7000 Unified

4 The information collection in the IBM Knowledge Center contains all of the
4 information that is required to install, configure, and manage the system. The
4 information collection in the IBM Knowledge Center is updated between product
4 releases to provide the most current documentation. The information collection is
4 available at the following website:

publib.boulder.ibm.com/infocenter/storwize/unified_ic/index.jsp

Storwize V7000 Unified library

Unless otherwise noted, the publications in the library are available in Adobe portable document format (PDF) from a website.

www.ibm.com/e-business/linkweb/publications/servlet/pbi.wss

Click **Search for publications** to find the online publications you are interested in, and then view or download the publication by clicking the appropriate item.

Table 1 lists websites where you can find help, services, and more information.

Table 1. IBM websites for help, services, and information

Website	Address
IBM home page	http://www.ibm.com
Directory of worldwide contacts	http://www.ibm.com/planetwide
Support for Storwize V7000 (2076)	www.ibm.com/storage/support/storwize/v7000
Support for Storwize V7000 Unified (2073)	www.ibm.com/storage/support/storwize/v7000/unified
Support for IBM System Storage® and IBM TotalStorage products	www.ibm.com/storage/support/

Each of the PDF publications in the Table 2 library is also available in the IBM Knowledge Center by clicking the number in the “Order number” column:

Table 2. Storwize V7000 Unified library

Title	Description	Order number
IBM Storwize V7000 Model 2073-720 Quick Start Guide	The guide provides general instructions for installing your system, and is intended for experienced developers.	
<i>Storwize V7000 Unified Quick Installation Guide</i>	The guide provides instructions for unpacking your order and installing your system. The first chapter describes verifying your order, becoming familiar with the hardware components, and meeting environmental requirements. The second chapter describes installing the hardware and attaching data cables and power cords. The last chapter describes accessing the management GUI to initially configure your system.	
<i>IBM Storwize V7000 Expansion Enclosure Installation Guide, Machine type 2076</i>	The guide provides instructions for unpacking your order and installing the 2076 expansion enclosure for the Storwize V7000 Unified system.	
<i>Adding Storwize V7000 Unified File modules to an Existing Storwize V7000 System</i>	The guide is for adding Storwize V7000 file modules to an existing Storwize V7000 system to create a Storwize V7000 Unified system.	
<i>Storwize V7000 Unified Problem Determination Guide</i>	The guide describes how to service, maintain, and troubleshoot the Storwize V7000 Unified system.	
<i>IBM Storwize V7000 Unified Safety Notices</i>	The guide contains translated caution and danger statements for the node canister documentation. Each caution and danger statement in the Storwize V7000 Unified documentation has a number that you can use to locate the corresponding statement in your language in the <i>IBM Storwize V7000 Unified Safety Notices</i> document.	

Table 2. Storwize V7000 Unified library (continued)

Title	Description	Order number
<i>Safety Information</i>	The guide contains translated caution and danger statements for the file module documentation. Each caution and danger statement in the Storwize V7000 Unified documentation has a number. Use the number to locate the corresponding statement in your language in the <i>Safety Information</i> document.	
<i>Storwize V7000 Unified Read First Flyer</i>	This document introduces the major components of the Storwize V7000 Unified system and describes how to get started with the <i>Storwize V7000 Unified Quick Installation Guide</i> .	
<i>Read First before adding file modules to an existing Storwize V7000 Unified</i>	This document introduces the major components of the Storwize V7000 Unified system and describes how to get started with <i>Adding Storwize V7000 Unified File modules to an Existing Storwize V7000 System</i> .	
<i>IBM Statement of Limited Warranty (2145 and 2076)</i>	This multilingual document provides information about the IBM warranty for machine types 2145 and 2076.	
<i>IBM Statement of Limited Warranty (2073)</i>	This multilingual document provides information about the IBM warranty for machine type 2073.	
<i>IBM License Agreement for Machine Code</i>	This multilingual guide contains the License Agreement for Machine Code for the Storwize V7000 Unified product.	
<i>Getting Started with Real-time Compression™ on IBM Storwize(r) V7000 Unified 1.4.0.1</i>	This document provides technical information and guidelines on what to consider to deploy compression in the Storwize V7000 Unified storage environment.	
<i>IBM Storwize(r) V7000 Unified Data Migration Guide: NetApp to IBM Storwize(r) V7000 Unified</i>	This document is a guide for migrating data from a NetApp system to an IBM Storwize(r) V7000 Unified NAS platform.	

IBM documentation and related websites

Table 3 lists websites that provide publications and other information about the Storwize V7000 Unified or related products or technologies. The IBM Redbooks® publications provide positioning and value guidance, installation and implementation experiences, solution scenarios, and step-by-step procedures for various products.

Table 3. IBM documentation and related websites

Website	Address
IBM Publications Center	www.ibm.com/e-business/linkweb/publications/servlet/pbi.wss
IBM Redbooks publications	www.redbooks.ibm.com/

Related accessibility information

To view a PDF file, you need Adobe Reader, which can be downloaded from the Adobe website:

www.adobe.com/support/downloads/main.html

How to order IBM publications

The IBM Publications Center is a worldwide central repository for IBM product publications and marketing material.

The IBM Publications Center offers customized search functions to help you find the publications that you need. Some publications are available for you to view or download at no charge. You can also order publications. The publications center displays prices in your local currency. You can access the IBM Publications Center through the following website:

www.ibm.com/e-business/linkweb/publications/servlet/pbi.wss

Related websites

The following websites provide information about Storwize V7000 Unified or related products or technologies.

Type of information	Website
Storwize V7000 Unified support	www.ibm.com/storage/support/storwize/v7000/unified
Technical support for IBM storage products	www.ibm.com/storage/support/
IBM Electronic Support registration	www.ibm.com/support/electronicssupport

Sending your comments

Your feedback is important in helping to provide the most accurate and highest quality information.

To submit any comments about this book or any other Storwize V7000 Unified documentation, send your comments by email to starpubs@us.ibm.com. Include the following information in your email:

- Publication title
- Publication form number
- Page, table, or illustration numbers that you are commenting on
- A detailed description of any information that should be changed

How to get information, help, and technical assistance

If you need help, service, technical assistance, or just want more information about IBM products, you will find a wide variety of sources available from IBM to assist you.

Information

IBM maintains pages on the web where you can get information about IBM products and fee services, product implementation and usage assistance, break and fix service support, and the latest technical information. For more information, refer to Table 4.

Table 4. IBM websites for help, services, and information

Website	Address
IBM home page	http://www.ibm.com
Directory of worldwide contacts	http://www.ibm.com/planetwide
Support for Storwize V7000 (2076)	www.ibm.com/storage/support/storwize/v7000
Support for Storwize V7000 Unified (2073)	www.ibm.com/storage/support/storwize/v7000/unified
Support for IBM System Storage and IBM TotalStorage products	www.ibm.com/storage/support/

Note: Available services, telephone numbers, and web links are subject to change without notice.

Help and service

Before calling for support, be sure to have your IBM Customer Number available. If you are in the US or Canada, you can call 1 (800) IBM SERV for help and service. From other parts of the world, see <http://www.ibm.com/planetwide> for the number that you can call.

When calling from the US or Canada, choose the **storage** option. The agent decides where to route your call, to either storage software or storage hardware, depending on the nature of your problem.

If you call from somewhere other than the US or Canada, you must choose the **software** or **hardware** option when calling for assistance. Choose the **software** option if you are uncertain if the problem involves the Storwize V7000 Unified software or hardware. Choose the **hardware** option only if you are certain the problem solely involves the Storwize V7000 Unified hardware. When calling IBM for service regarding the product, follow these guidelines for the **software** and **hardware** options:

Software option

Identify the Storwize V7000 Unified product as your product and supply your customer number as proof of purchase. The customer number is a 7-digit number (0000000 to 9999999) assigned by IBM when the product is purchased. Your customer number should be located on the customer information worksheet or on the invoice from your storage purchase. If asked for an operating system, use **Storage**.

Hardware option

Provide the serial number and appropriate 4-digit machine type. For Storwize V7000 Unified, the machine type is 2073.

In the US and Canada, hardware service and support can be extended to 24x7 on the same day. The base warranty is 9x5 on the next business day.

Getting help online

You can find information about products, solutions, partners, and support on the IBM website.

To find up-to-date information about products, services, and partners, visit the IBM website at www.ibm.com/storage/support/storwize/v7000/unified.

Before you call

Make sure that you have taken steps to try to solve the problem yourself before you call.

Some suggestions for resolving the problem before calling IBM Support include:

- Check all cables to make sure that they are connected.
- Check all power switches to make sure that the system and optional devices are turned on.
- Use the troubleshooting information in your system documentation. The troubleshooting section of the information center contains procedures to help you diagnose problems.
- Go to the IBM Support website at www.ibm.com/storage/support/storwize/v7000/unified to check for technical information, hints, tips, and new device drivers or to submit a request for information.

Using the documentation

Information about your IBM storage system is available in the documentation that comes with the product.

That documentation includes printed documents, online documents, readme files, and help files in addition to the information center. See the troubleshooting information for diagnostic instructions. The troubleshooting procedure might require you to download updated device drivers or software. IBM maintains pages on the web where you can get the latest technical information and download device drivers and updates. To access these pages, go to www.ibm.com/storage/support/storwize/v7000/unified and follow the instructions. Also, some documents are available through the IBM Publications Center.

Sign up for the Support Line Offering

If you have questions about how to use and configure the machine, sign up for the IBM Support Line offering to get a professional answer.

The maintenance supplied with the system provides support when there is a problem with a hardware component or a fault in the system machine code. At times, you might need expert advice about using a function provided by the system or about how to configure the system. Purchasing the IBM Support Line offering gives you access to this professional advice while deploying your system, and in the future.

Contact your local IBM sales representative or your support group for availability and purchase information.

What's new

This publication provides information that helps you install and initialize the IBM Storwize V7000 Unified system.

GC27-5945-02

The following table describes current technical changes and enhancements to this guide:

New information	<ul style="list-style-type: none">• New model of block volume storage system (Storwize V7000 Gen2 2076-524 control enclosure plus 2076-12F and 2076-24F expansion enclosures)• Minor changes and fixes
Changed information	<ul style="list-style-type: none">• Simplified graphics• Miscellaneous revisions throughout this publication

Chapter 1. Before you begin the installation

This information contains a set of instructions to help you plan your installation.

The *Quick Installation Guide* contains a set of instructions to help you unpack and install your system. The guide is divided into three chapters. The steps in the first chapter involve verifying your order, becoming familiar with the hardware component terminology, and ensuring that you have met the environmental requirements. The steps in the second chapter involve installing the hardware and attaching the data cables and power cords. The final chapter helps you configure the file modules and control enclosures. It ends with enabling the Tivoli Assist On-site support program.

Occasionally you are referred to topics in the Storwize V7000 Unified Information Center.

Important information:

1. You must first work through the planning information regarding your physical environment and logical network in the Storwize V7000 Unified Information Center.
2. Ensure that you have available any cables that you are supplying.
3. Pay attention to any flyers that were shipped with the order that you received.
4. Check the IBM support home page for any information relevant to planning, installing and configuring a Storwize V7000 Unified system:
<http://www.ibm.com/storage/support/storwize/v7000/unified>
5. The Initial setup e-Learning module is available on the IBM Storwize V7000 Unified Information Center. Refer to “Initial set up”, located under Learning and tutorials.
6. You must use the management GUI to update to the latest Storwize V7000 Unified software immediately after completing the initial configuration.
7. Event notifications and call homes from the Storwize V7000 storage enclosures are done by e-mail. The IP address of an e-mail server which can access the internet is required. Call home from a file module is done by electronic customer care (ecc) using ssh. This requires a proxy server to access the internet or your firewall must be made to allow each file module service IP address to ssh to the IBM call home IP addresses (*.ibm.com) on the internet.

IBM Storwize V7000 Unified Information Center

The most current information for Storwize V7000 Unified is available in the *IBM Storwize V7000 Unified Information Center* at publib.boulder.ibm.com/infocenter/storwize/unified_ic/index.jsp.

Step 1. Reviewing your packing slip

Check that your packing slip matches the ship contents.

After you open your box or boxes, locate your packing slip. Ensure that the items that are listed in your packing slip match what is in the box. Ensure that any optional items that you ordered are included in the list. Your shipment might contain additional items depending on the order.

Control enclosure ship contents:

- ___ • Control enclosure (models 2076-524, 2076-112, 2076-124, 2076-312, or 2076-324).
The last two digits of the model number identify the number of drive slots, either 12 or 24.
 - ___ • Rack-mounting hardware kit, including:
 - ___ – Two rails (right and left assembly)
 - ___ – Two M5 x 15 Hex Phillips screws per rail (two rails)
 - ___ – Two M5 x 15 Hex Phillips screws per chassis
- Note:** Two parts of the rail kit are attached to each side of the enclosure.
- ___ • Two power cords
 - ___ • Drive assemblies or blank carriers (installed in the enclosure).
Verify the number of drives and the size of the drives.

Other items shipped with control enclosure:

- ___ • Read first flyer
- ___ • Quality hotline flyer
- ___ • Environmental notices CD
- ___ • Environmental flyers
- ___ • Safety notices
- ___ • Limited Warranty information
- ___ • License information
- ___ • License Function authorization document
- ___ • IBM Storwize V7000 Unified Quick Installation Guide
- ___ • *Storwize V7000 Unified Problem Determination Guide*
- ___ • One USB flash drive is located with the publications.

Additional components for control enclosure:

- ___ • Fibre Channel cables, if ordered
- ___ • Small form-factor pluggable (SFP) transceivers that are preinstalled in the enclosure
- ___ • Longwave SFP transceivers, if ordered

Additional components for expansion enclosures:

- ___ • Two SAS cables for each expansion enclosure

Two file modules. Each file module box contains:

- ___ • File module (server)
- ___ • Rack-mounting hardware kit, including:
 - ___ – Two sets of two rails (right and left assembly)
 - ___ – Large cable tie
 - ___ – Cable ties
 - ___ – Two sets of four M6 screws per rail (two rails)
 - ___ – Two sets of two 10-32 screws per chassis
 - ___ – Cable management support arm
 - ___ – Cable management arm mounting bracket
 - ___ – Cable management arm stop bracket

__ – Cable management arm assembly

Note: The rail kits for the servers differ from the control enclosure.

- __ • Two power cords

Additional components for file modules:

- __ • Read first flyer
- __ • Quality hotline flyer
- __ • Environmental notices CD
- __ • Environmental flyers
- __ • Safety notices
- __ • Limited warranty information
- __ • License information
- __ • License Function authorization document
- __ • Small form-factor pluggable (SFP) transceivers that are preinstalled in the ports.

Step 2. Identifying the hardware components

The following graphics and descriptions identify the various hardware components and port locations for the control enclosure, expansion enclosure, and file modules.

Control enclosure

Each enclosure has drives that are located on the front. Figure 1 and Figure 2 show the front of an enclosure that has space for up to 12 or 24 drives **2**, depending on the model, and a left end cap **1** and a right end cap **3**.

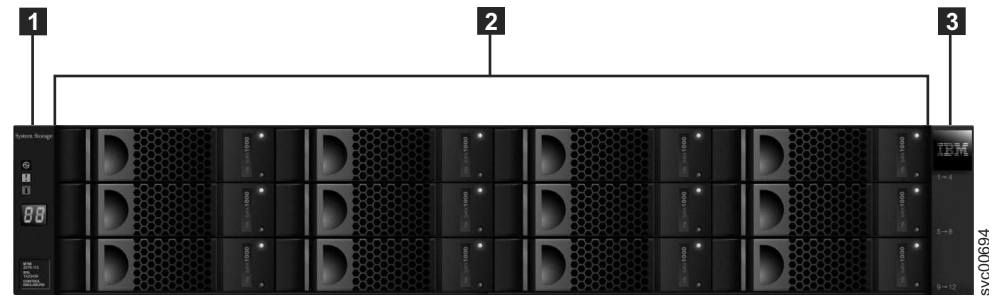

Figure 1. This figure shows 12 drives and two end caps (model 2076-112).



Figure 2. This figure shows 24 drives and two end caps (model 2076-124).

Control enclosure components

Figure 3 shows the rear view of a control enclosure and identifies the location of the power supply units and the canisters.

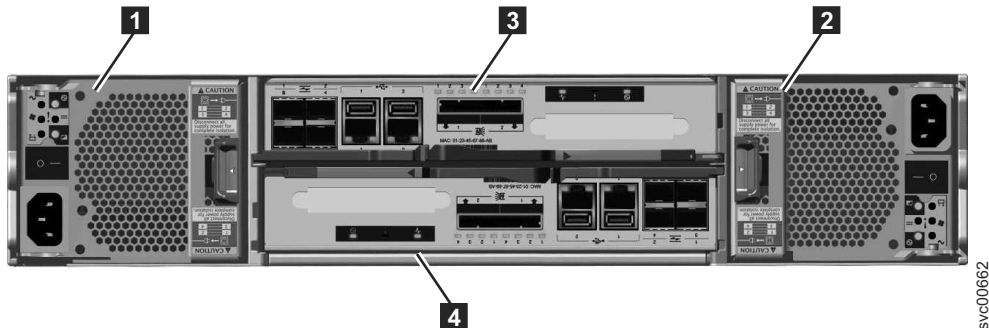

Figure 3. Rear view of a model 2076-112 or a model 2076-124 control enclosure

- Power supply units are located on the left and right of the canisters. Each unit contains a battery. Power supply **1** is located on the left. Power supply **2** is located on the right. Power supply **1** is inserted top side up, and power supply **2** is inverted, or top side down.

Important: The power supply units for the control enclosure and expansion enclosure are not interchangeable.

- Two canisters are housed in the middle of the enclosure. Each canister is known as a node canister. The upper canister, as shown in Figure 3, is labeled **3**, and the lower canister is labeled **4**. Canister **3** is top side up, and canister **4** is inverted, or top side down.

Figure 4 on page 5 shows the rear view of a model 2076-112 or a model 2076-124 control enclosure and identifies the location of the ports.

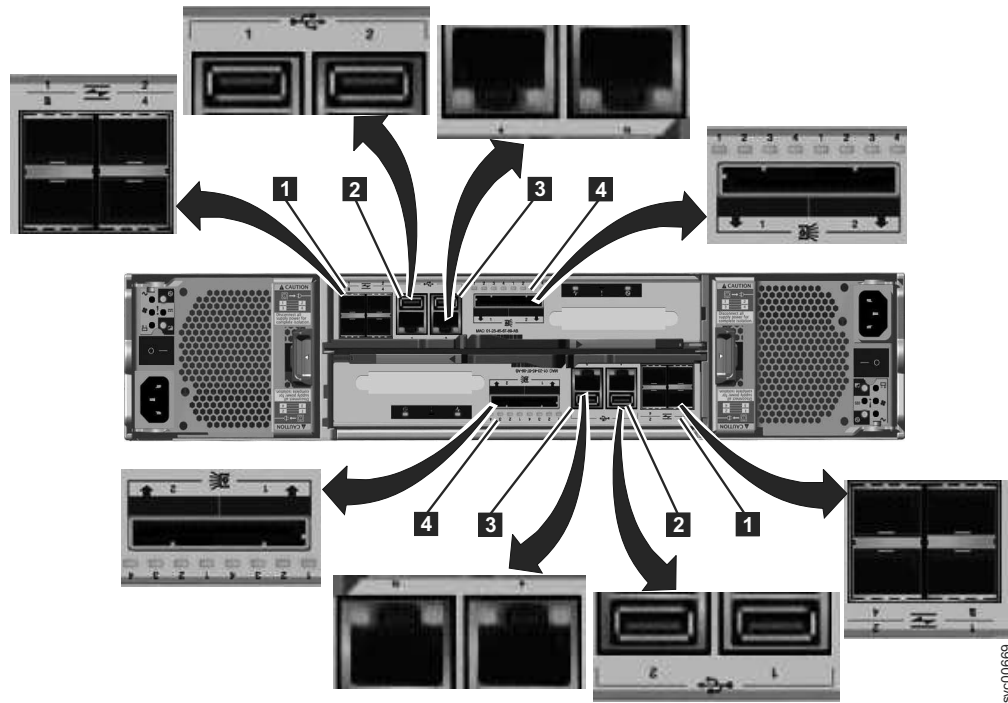
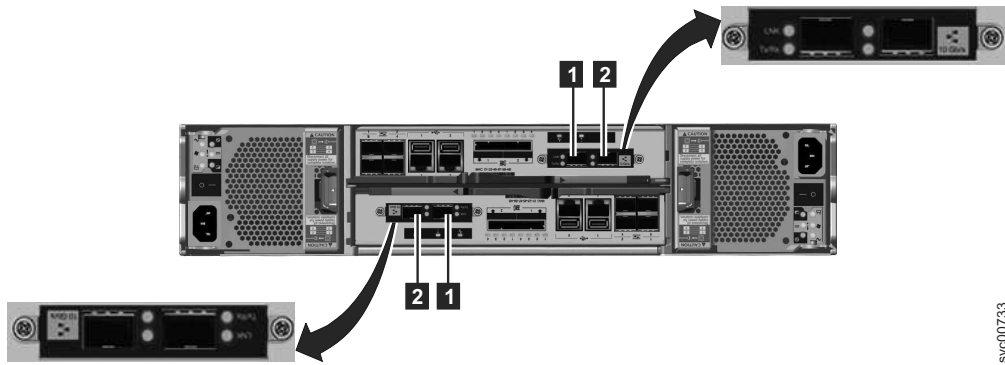

Figure 4. This figure shows the data ports in the rear of the control enclosure.

- 1** Fibre Channel ports. Each canister has four Fibre Channel ports. They are in a block of four in two rows of two connectors. The ports are numbered 1 - 4 from left to right, top to bottom. Two ports connect to the file modules and two are optional.
- 2** USB ports. Each canister has two USB ports. The ports are side by side on the canister and are numbered 1 on the left and 2 on the right. One port is used during installation.
- 3** Ethernet ports. Each canister has two Ethernet ports. The ports are side by side on the canister. They are numbered 1 on the left and 2 on the right on the upper canister. The port locations are inverted for the lower canister. Port 1 must be connected first; the use of port 2 is optional.
- 4** Serial-attached SCSI (SAS) ports. Each canister has two SAS ports. The ports are side by side on the canister. They are numbered 1 on the left and 2 on the right. Port 1 must be connected first if you are adding one expansion enclosure. Port 2 must be connected if you are adding a second expansion enclosure.

Note: The reference to the left and right locations applies to canister 1, which is the upper canister. The port locations are inverted for canister 2, which is the lower canister.

Figure 5 on page 6 shows the rear view of a model 2076-312 or a model 2076-324 control enclosure with the optional 10 Gbps Ethernet ports installed. All other ports remain the same.



svc00733

Figure 5. 10 Gbps Ethernet ports on the rear of the Storwize V7000 enclosure

- 1** 10 Gbps Ethernet port 3 which is the left port
- 2** 10 Gbps Ethernet port 4 which is the right port

Figure 6 shows the rear view of a Storwize V7000 Gen2 control enclosure and identifies the location of the node canisters and power supply units.

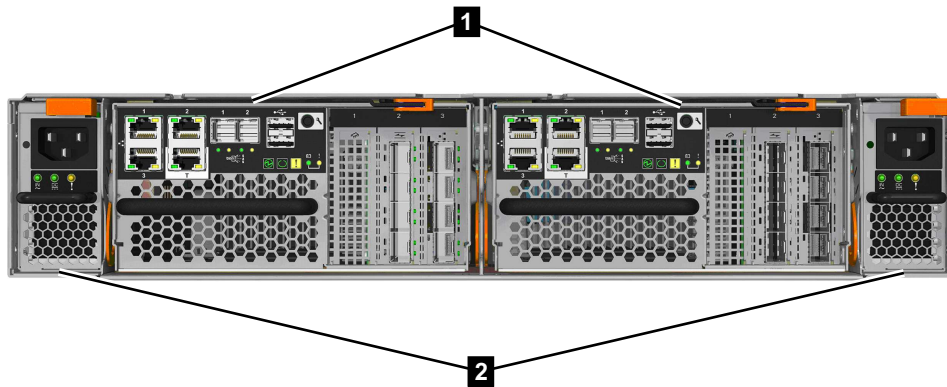

fab10003

Figure 6. Rear view of a Storwize V7000 Gen2 control enclosure (2076-524)

- 1** Node canisters.
- 2** Power supply units.

Figure 7 shows the rear view of a Storwize V7000 Gen2 control enclosure and identifies the location of the ports.



fab10004

Figure 7. Data ports in the rear of the Storwize V7000 Gen2 control enclosure (2076-524)

- **1** USB ports. Each canister has two USB ports.
- **2** Ethernet ports. Each canister has four 10 Gbps Ethernet ports.

- **3** Serial-attached SCSI (SAS) ports. Each canister has two SAS ports for connecting to optional expansion enclosures.

Expansion enclosure components

Figure 8 shows the rear view of an expansion enclosure and identifies the location of the power supply units and the canisters. The ports and their use are described later in this section.

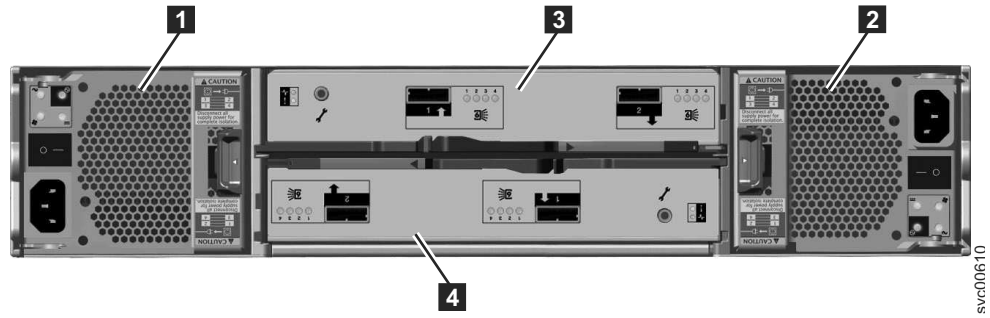

Figure 8. Rear view of a model 2076-212 or a model 2076-224 expansion enclosure

- Power supply units are on the left and right of the canisters. Power supply **1** is located on the left. Power supply **2** is located on the right. Power supply 1 is inserted top side up, and power supply 2 is inverted, or top side down.

Important: The power supply units for the control enclosure and expansion enclosure are not interchangeable.

- Two canisters are housed in the middle of the enclosure. Each canister is known as an expansion canister. The upper canister, as shown in Figure 8, is canister **3**, and the lower canister is canister **4**. Canister 3 is top side up, and canister 4 is inverted, or top side down.

Figure 9 on page 8 shows the rear view of an expansion enclosure and identifies the SAS port locations.

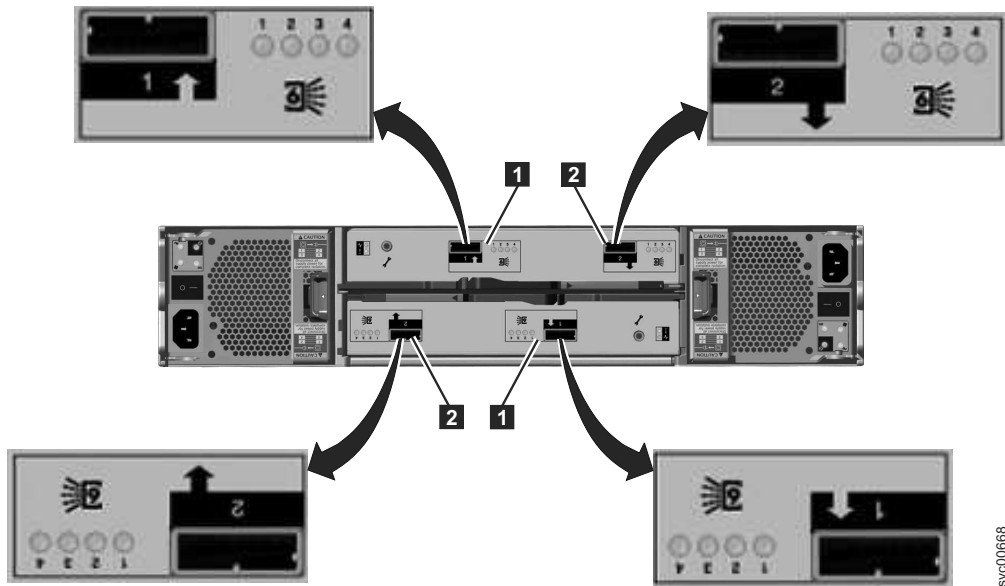

Figure 9. SAS ports and LEDs in rear of expansion enclosure

Each canister has two SAS ports that are numbered 1 on the left **1** and 2 on the right **2**. Port 1 must be connected if you are adding one expansion enclosure. Port 2 must be connected if you are adding a second expansion enclosure.

Note: The reference to the left and right locations applies to canister 1, which is the upper canister. The port locations are inverted for canister 2, which is the lower canister.

Figure 10 shows the rear view of a Storwize V7000 Gen2 expansion enclosure and identifies the location of power supply units and expansion canisters.

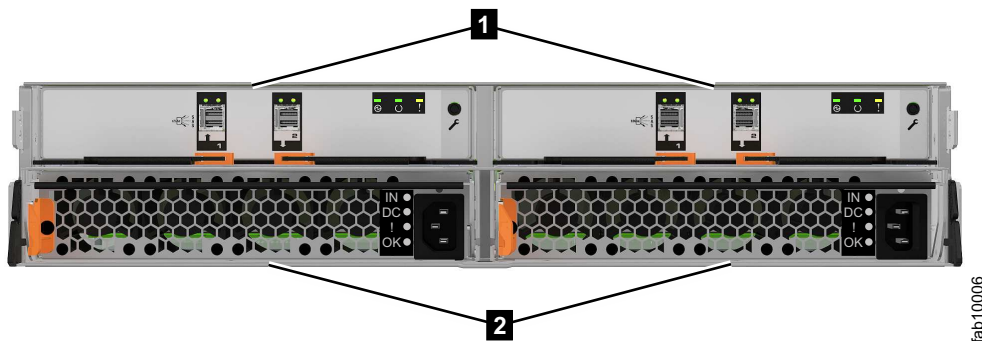

Figure 10. Rear view of a Storwize V7000 Gen2 expansion enclosure

- 1** Expansion canisters
- 2** Power supply units

Figure 11 on page 9 shows the rear view of a Storwize V7000 Gen2 expansion canister and identifies the SAS port locations.

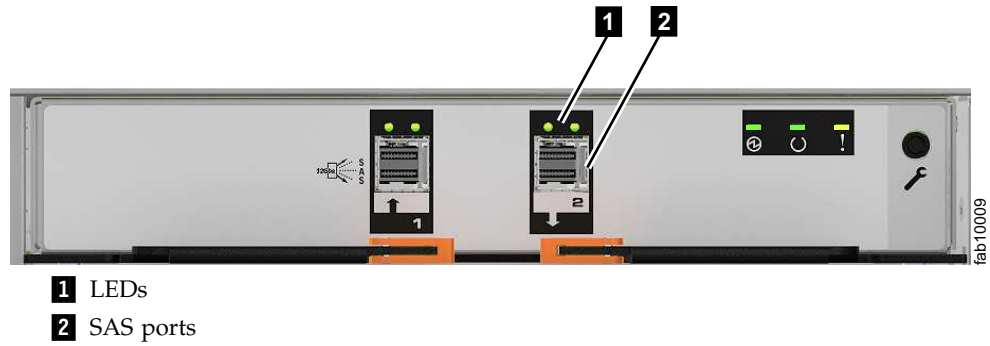

Figure 11. SAS ports and LEDs in rear of a Storwize V7000 Gen2 expansion canister

Each canister has two SAS ports that are numbered 1 on the left and 2 on the right. Port 1 is used to connect to a SAS expansion port on a node canister or port 2 of another expansion canister.

File module

Figure 12 and Figure 13 on page 10 identify the various ports and hardware in the front of the file module. Each enclosure takes up the full 2U height in the rack. See the *Storwize V7000 Unified Problem Determination Guide* PDF on the CD for the full descriptions of the hardware components.

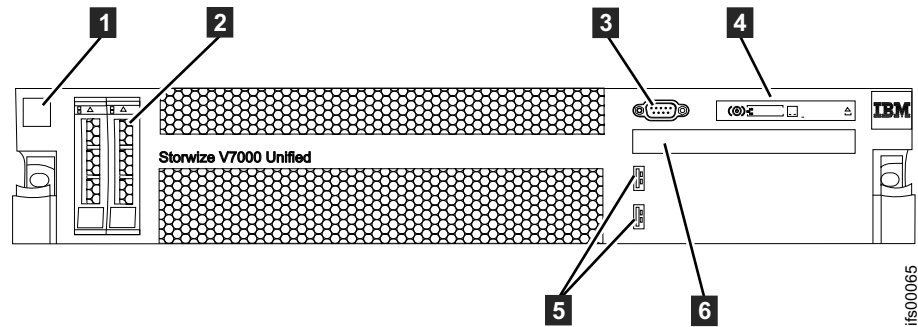

Figure 12. Front view of 2073-720 file module

- **1** File module label with MTM (machine type model) and S/N (serial number)
- **2** Boot drives
- **3** Video port
- **4** Advanced operator panel.
- **5** USB ports
- **6** DVD drive

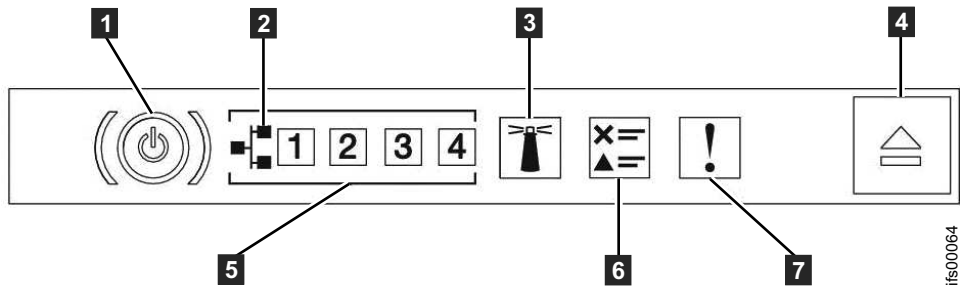

Figure 13. 2073-720 file module advanced operator panel

- **1** Power-control button and power-on LED (green)
- **2** Ethernet icon
- **3** System-locator button and LED (blue)
- **4** Release latch for the light path diagnostics panel
- **5** Ethernet activity LEDs
- **6** Check log LED
- **7** System-error LED: (yellow)

Figure 14 identifies the various ports and hardware in the rear of the file module:

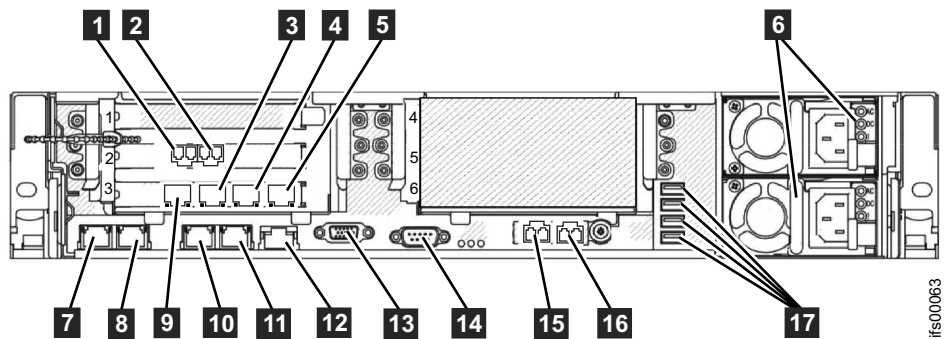

Figure 14. Rear view of 2073-720 file module

- **1** 8 Gbps Fibre Channel port 1 (connected to the control enclosure)
- **2** 8 Gbps Fibre Channel port 2 (connected to the control enclosure)
- **3** Ethernet port 8
- **4** Ethernet port 9
- **5** Ethernet port 10
- **6** Power supplies (1 is lower 2 is upper)
- **7** Ethernet port 1 (connected to the other file module)
- **8** Ethernet port 2 (connected to the other file module)
- **9** Ethernet port 7
- **10** Ethernet port 3
- **11** Ethernet port 4
- **12** Systems-management Ethernet port (NOT USED)
- **13** Video port
- **14** Serial port
- **15** Ethernet port 5 (10 Gbps)

- **16** Ethernet port 6 (10 Gbps)
- **17** USB ports

Miscellaneous hardware

The USB flash drive is packaged with the publications and contains the initialization tool for performing the initial system configuration.

Step 3. Verifying environmental requirements

Verify that the physical requirements are met.

Certain requirements for the physical site must be met to ensure that your system works reliably. This step includes verifying that adequate space in a suitable rack is available and that requirements for power and environmental conditions are met. This documentation assumes that you have completed the physical planning for the environment of your system.

If you have not done the environmental planning for your system, see the *Storwize V7000 Unified physical installation planning* topic in the Storwize V7000 Unified Information Center.

You must use a supported web browser. Verify that you are using a supported web browser from the following website:

http://publib.boulder.ibm.com/infocenter/storwize/unified_ic/topic/com.ibm.storwize.v7000.unified.130.doc/svc_configuringbrowser_1obg15.html

Step 4. Reviewing enclosure location guidelines

Create a plan that identifies appropriate rack locations for your system.

Control enclosure:

Follow these guidelines to create a plan that identifies an appropriate location in the rack for the enclosure and file modules that you are installing now or will be installing later.

Note: These guidelines assume that you are installing a new enclosure or enclosures. If you are adding enclosures to an existing rack, you must consider the amount of space available and the length of cables to the enclosure.

If you are installing a control enclosure only, follow these guidelines:

Position the enclosure in the rack so that you can easily view it and access it for servicing. This action helps the rack to remain stable and provides a way for two or more people to install and remove the enclosure.

If you are installing a control enclosure plus one or more expansion enclosures, follow these guidelines:

If you have one or more expansion enclosures, position the control enclosure in the middle of the expansion enclosures. Balance the expansion enclosures above and below the control enclosure. Refer to Figure 15 on page 13.

For example, position the control enclosure in the middle of the enclosures for ease of cabling.

- You can have no more than five expansion enclosures attached to SAS port 1 of the control enclosure.
- You can have no more than four expansion enclosures attached to SAS port 2 of the control enclosure.
- Position the enclosures together; avoid adding other equipment between enclosures.
- When you add the first expansion enclosure to a control enclosure, it is preferable to add the enclosure directly below the control enclosure.
- When you add a second expansion enclosure, it is preferable to add the enclosure directly above the control enclosure. For each additional expansion enclosure that you add, alternately add it below or above the control enclosure.
- Position the enclosures in the rack so that you can easily view them and access them for servicing. This action helps the rack to remain stable and provides a way for two or more people to install and remove the enclosures.

If you are installing an expansion enclosure to an existing system, follow these guidelines:

When you add the first expansion enclosure to a control enclosure, it is preferable to add the enclosure directly below the control enclosure. When you add a second expansion enclosure, it is preferable to add the enclosure directly above the control enclosure. For each expansion enclosure that you add, alternately add it below or above the control enclosure. Refer to Figure 15 on page 13.

If you are adding an expansion enclosure to an existing system, you do not need to power off the system. You can add an expansion enclosure while the system is operational.

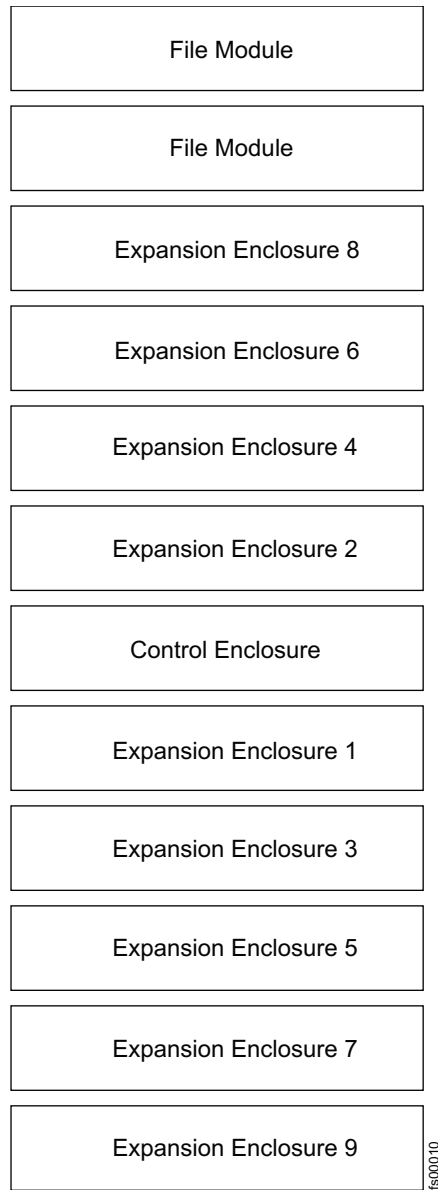

Figure 15. Recommended rack locations

File modules:

- Install both file modules in adjacent slots, near the control enclosure. Other configurations are possible, but all racks must be close together to accommodate cable lengths. A floor plan showing the layout must be developed prior to the start of the installation.

Step 5. Gather information

Gather system information, such as IP addresses, prior to system configuration and initialization.

You need to have some information ready before you begin the initialization of your system, such as the IP addresses. Refer to “Information required before initializing your system” on page 14.

You will need to have some information ready before you start the initial configuration of your system using the management GUI. Refer to “Information required before starting initial configuration of your system” on page 17.

Checking that IP addresses are not already in use

It is very important to check that the IP addresses that you give to the InitTool.exe are not already in use.

About this task

If you provide an IP address that is already in use then the initial setup may appear to be successful and the system could work for some time before random problems start to happen, which could be very hard to troubleshoot.

A reliable way to check that an IP address is not already in use is to logon to a machine that is in the same subnet as the Storwize V7000 Unified system will use for management communications. Then ping the new IP addresses. For example, ping each of the IP addresses that you intend to use in the InitTool.exe. Note that the security setup of your network may not allow IP hosts to respond to ping.

Follow this process:

1. Log on any machine which is on the same network subnet that the Storwize V7000 Unified system will use for management communications. That is, it has the same network gateway IP address set and the same subnet mask set as the Unified system will use.
2. Ping the network Gateway IP address that the Storwize V7000 Unified system will use. This should indicate 0% packet loss. For example:
ping 123.123.123.1
3. If 2 was successful then ping each of the following IP addresses that you will be providing to InitTool.exe. Each should indicate 100 % packet loss.
 - Storwize V7000 system primary IP address
 - Storwize V7000 system secondary IP address 2 (if you intend to set this)
 - Storwize V7000 node canister 1 service IP address (if you intend to set this)
 - Storwize V7000 node canister 2 service IP address (if you intend to set this)
 - Storwize V7000 Unified management IP address
 - File module 1 IP address
 - File module 2 IP address
4. If you are utilizing DNS on your network, then the DNS entry for each IP in 3 should also be checked utilizing the **nslookup** command to ensure that the DNS names match what you expect. nslookup can be used the same way in Linux, Windows and MacOS):
nslookup<IP Address> For example, Output from Windows 7:
nslookup 123.123.123.10
Server: mydns.mysite.com
Address: 123.123.123.102
Name: mysys.mysite.com
Address: 123.123.123.10

Information required before initializing your system

Use this information to help you prepare to initialize your system.

About this task

The information in Table 5 on page 16 is required before initializing your system. Fill in all the information needed in the **Value** column before starting the initial setup of your system using the Initialization tool (InitTool.exe).

You should also fill in all of the information needed in “Information required before starting initial configuration of your system” on page 17 before you start initializing your system.

Attention: You must check carefully that the IP addresses that you provide to InitTool.exe are valid and not already in use by some other system on the network apart from the gateway IP address. Refer to “Checking that IP addresses are not already in use” on page 14. If you provide an IP address that is already in use then the initial setup may appear to be successful and the system could work for some time before random problems start to happen which are very hard to troubleshoot.

If you need to change an IP address after initial setup has completed, then refer to Connectivity issues for the 2073-720, located in the Troubleshooting topic of the Information Center for examples of changing IP addresses.

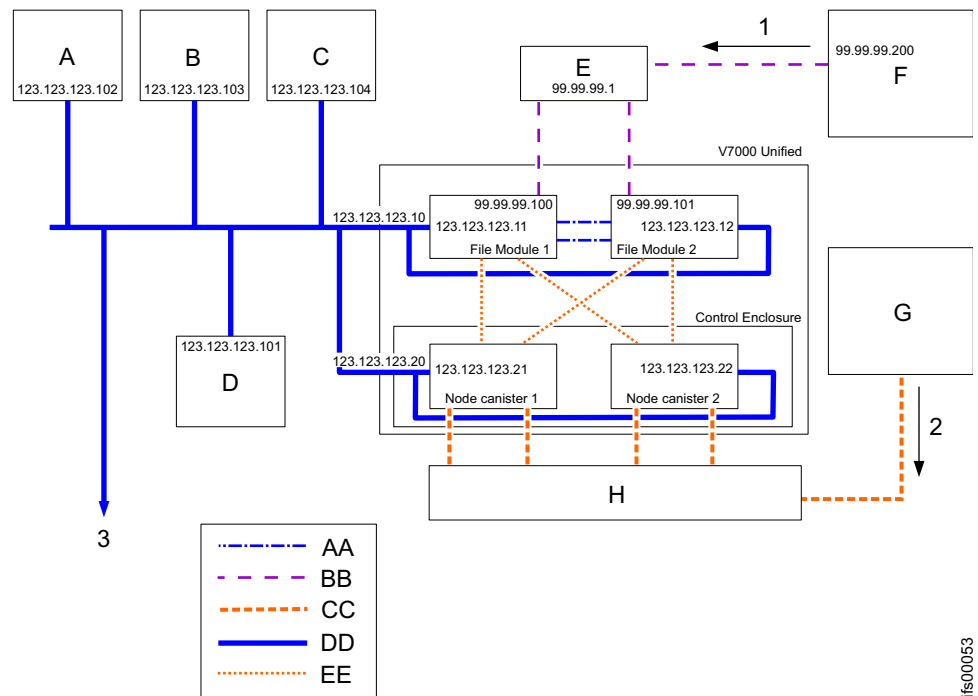

Figure 16. Example of IP addresses and connectivity

Legend for Figure 16:

- 1** File storage path
- 2** Block storage path
- 3** Remote support services via internet
- A** DNS server
- B** NTP server
- C** Email server
- D** Authentication server

- E** 10 Gbps Ethernet switch
- F** Client machine
- G** Client machine
- H** Fibre Channel switch
- AA** 1 Gbps Ethernet direct connection between the file modules
- BB** 10 Gbps Ethernet network
- CC** Fibre Channel network
- DD** 1 Gbps Ethernet
- EE** Fibre Channel direct connection from file modules to node canisters

The IP address information in Table 5 is required before initializing your system. Fill in all the information needed in the **Value** column before proceeding with this installation.

Table 5. Required IP address information

Field	Value	Notes
Storwize V7000 primary IP address		Primary management IP address for the Storwize V7000 system (such as 123.123.123.20)
Storwize V7000 secondary IP address		Optional secondary management IP address of the Storwize V7000 system (such as 123.123.123.19) This is not set by the USB initialize or through the initial configuration wizard in the management GUI. Refer to “Step 24. Next steps” on page 85 to help you configure this option later.
Storwize V7000 node canister 1 service IP address		Optional service IP address of canister 1 in the control enclosure (such as 123.123.123.21) This is not set by the USB initialize or through the initial configuration wizard in management GUI. Refer to “Step 24. Next steps” on page 85 to help you configure this option later.
Storwize V7000 node canister 2 service IP address		Service IP address of canister 2 in the control enclosure (such as 123.123.123.22) This is not set by the USB initialize or through the initial configuration wizard in management GUI. Refer to “Step 24. Next steps” on page 85 to help you configure this option later.
Network subnet mask		Subnet mask for the network subnet in which the management IP addresses for the system will all reside. (such as 255.255.255.0)
Network gateway IP address		The network gateway IP address for this subnet (such as 123.123.123.1)

Table 5. Required IP address information (continued)

Field	Value	Notes
Storwize V7000 Unified management IP address		Management IP address for the Storwize V7000 Unified system. This gives access to the management GUI and CLI running on which ever file module is currently the active management node (such as 123.123.123.10)
File module 1 IP address		The service access IP address assigned to file module 1 (such as 123.123.123.11)
File module 2 IP address		The service access IP address assigned to file module 2 (such as 123.123.123.12)

Note the following, before configuring the system network:

- You can install a Storwize V7000 Unified system in a user's VLAN network if the user's switch is set to "access" mode
- To configure the Storwize V7000 Unified management IP address, file module 1 and 2 IP addresses, subnet mask, and gateway address, you must provide non-VLAN based network information.
- All IP addresses entered must be on the same subnet.
- After the system is configured, use the **chnwmgmt** command to change the Storwize V7000 Unified network settings to switch to a VLAN-based subnet. This recreates the network with a VLAN-based subnet.
- You must use the **chsystem -consoleip** CLI command to show the Storwize V7000 the new management IP address.

Note: The Storwize V7000 service IP addresses are not set by the USB Initialize or by the initial configuration done through the management GUI. Refer to “Step 24. Next steps” on page 85 for how to set them.

Additional information must be ready before you start the initial configuration of your system using the “Step 18. Using the management GUI to complete the initial configuration of the system” on page 80. Refer to “Information required before starting initial configuration of your system.”

Information required before starting initial configuration of your system

Identify the information needed to configure your system using the management GUI.

About this task

You must enter specific information into the management GUI. The tables help you record the key values needed before the initial set up and initial configuration.

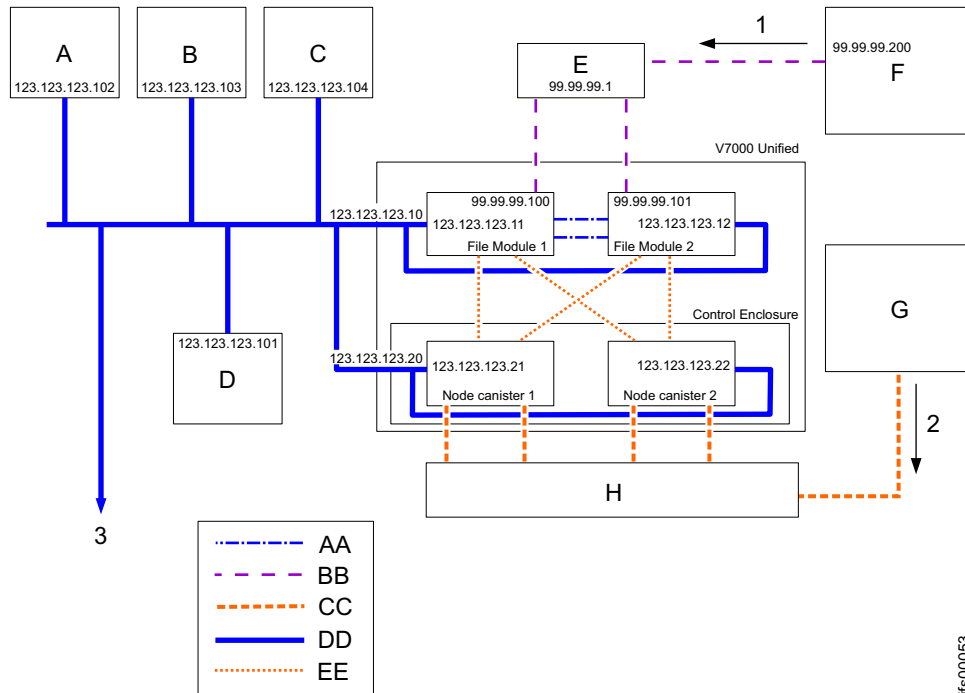

Figure 17. Example of IP addresses and connectivity

Legend for Figure 17:

- 1** File storage path
- 2** Block storage path
- 3** Remote support services via internet
- A** DNS server
- B** NTP server
- C** Email server
- D** Authentication server
- E** 10 Gbps Ethernet switch
- F** Client machine
- G** Client machine
- H** Fibre Channel switch
- AA** 1 Gbps Ethernet direct connection between the file modules
- BB** 10 Gbps Ethernet network
- CC** Fibre Channel network
- DD** 1 Gbps Ethernet
- EE** Fibre Channel direct connection from file modules to node canisters

Required information:

Fill out all the information in the following tables in order to navigate through the initial configuration wizard in the management GUI. Your chances of completing the initial configuration successfully are greatly increased if you have carefully planned and completed these tables before you start the initial setup and initial configuration of the system.

Table 6. Information required for the initial configuration wizard in the management GUI. The table entries serve as a guide only. Use the Value column to record your system information.

Field	Value	Notes
System name		The name of the Storwize V7000 Unified system. It is best if this is also the IP name for the management IP address (For example : myfilesystem1)
NetBIOS name		Name used for NetBIOS access to the system. Note: To change the NetBIOS name after the initial configuration, use the cfgcluster CLI command.
Time zone		Refer to Time Zone List in the IBM Storwize V7000 Unified Information Center. Example: If the machine is being installed in Tucson, Arizona, USA, the best match for the time zone is America/Phoenix. You will match this to a drop down menu located in the management GUI.
Network Time Protocol (NTP) Server		Site NTP server address (for example, 123.123.123.103)
Alternate NTP server		Alternate NTP server if applicable
VLAN ID		<ul style="list-style-type: none"> • If the file modules connect to an Ethernet Switch module configured in "access" mode, then no action is required. • If the file modules connect to an Ethernet Switch module configured in "trunk" mode, then enter a VLAN ID in the range of 2 to 4094. The Ethernet Switch must also be configured to allow this VLAN ID. 0-4095 are valid VLAN IDs, but 0, 1, and 4095 are reserved. Do not use 0, 1, and 4095 as VLAN IDs.
Domain name		This name is the public network domain name. Example: company.com The system name and domain name are typically used in combination. Example: myfilesytem1.company.com
DNS servers		Numerical address of user Domain Name Server (for example, 123.123.123.102) can be multiple server addresses
DNS search domain		Additional domain names to be used with primary domain name (for example, a.company.com or us.company.com)
Authentication method for network access to file systems		Refer to Table 10 on page 24, Table 11 on page 24, Table 12 on page 26, Table 13 on page 27 to set up your authentication method. When done, return here to continue.
Public subnet or subnets		Where subnet is the numeric IP address of the public network (data path). It is used for all of the Ethernet data path connections. Note: The Subnet is entered as the subnet address followed by the CIDR equivalent of the subnet mask (for example 99.99.99.0/24). You may have more than one public network to access the file systems and file sets shared by this system.
Public subnet mask or subnet masks		This is the subnet mask or subnet masks associated with the public subnet or subnets (for example, 255.255.255.0).

Table 6. Information required for the initial configuration wizard in the management GUI (continued). The table entries serve as a guide only. Use the Value column to record your system information.

Field	Value	Notes
CIDR equivalent of the subnet mask		This is the CIDR (/XX) equivalent of the subnet mask that was specified previously. Look up the subnet mask (specified previously) then refer to the Table 9 on page 21 and find the CIDR equivalent and record it on this line. It must be between /0 and /32 (for example, /24).
Default gateway IP address		This is the numeric gateway IP address. It is used for all network access to the file systems. For example, 99.99.99.1
Public IP addresses		The public IP addresses are the data path connections to your network. They are used for all of the Ethernet data path connections the file modules. At least 2 addresses are recommended (1 per node). The data path connections use Ethernet bonding, so a single IP address (along with a subnet mask and gateway) is used for all available Ethernet ports on a single file module. The system automatically load balances between the physical ports on a single file module. (For example, 99.99.99.100, 99.99.99.101,99.99.99.102,99.99.103)
Additional public gateway IP addresses		Additional gateways IP addresses for access to the file systems across each of the public networks.
Email server IP address		The IP address of your email server for outgoing mail (for example, 123.123.123.104)

Table 7. Information that the system provides to IBM Remote Technical Support

Field	Value	Note
Company Name		The name of your company
Address		This is the address where the machines are located. Example: Bldg. 123, Room 456, 789 N Data Center Rd, City, State
Your Contact Phone Number		This is the primary phone number that IBM Remote Technical Support will call, if the system calls home to report a problem.
Your Off Shift Contact Phone Number		This is the alternate phone number that IBM Remote Technical Support will call, if the system calls home to report a problem.
IP address of proxy server (for call home)	_____	Optional. If a proxy server is needed to access the internet for Call Home from the file modules, this is the IP address of that server. If no proxy server is used, leave this field blank.
Port Of Proxy Server (For Call Home)		Optional. If a proxy server is needed, this is the port corresponding to the IP address listed previously. If no proxy server is used, leave this field blank.
Userid For Proxy Server (For Call Home)		Optional. If a proxy server is needed, and the proxy server requires a user ID and password, record the user ID here. If no proxy server is used, or no user ID and password are used, leave this field blank.

Table 7. Information that the system provides to IBM Remote Technical Support (continued)

Field	Value	Note
Password For Proxy Server (For Call Home)		Optional. If a proxy server is needed, and the proxy server requires a user ID and password, record the password here. If no proxy server is used, or no user ID and password are used, leave this field blank.
IBM Support email address	callhome1@de.ibm.com callhome0@de.ibm.com	<ul style="list-style-type: none"> callhome1@de.ibm.com: For Storwize V7000 Unified systems located in North America, Latin America, South America or the Caribbean Islands. callhome0@de.ibm.com: For Storwize V7000 Unified systems located anywhere else in the world.

If a proxy server is not used, your network must provide access to the following addresses and ports to facilitate call home from each of the file module service IP addresses. Note that call home from one of the storage enclosures is done using email.

Table 8. Required information

Host Name	IP Address	Port	Description
eccgw01.boulder.ibm.com	207.25.252.197	443	ECC transaction gateway
eccgw02.rochester.ibm.com	129.42.160.51	443	ECC transaction gateway
ftp.ecurep.ibm.com	192.109.81.7	20, 21	File upload for status reporting and problem reporting through FTP
www6.software.ibm.com	170.225.15.41	443	File upload for status reporting and problem reporting. Proxy to testcase.boulder.ibm.com
www-945.ibm.com	129.42.26.224	443	Problem reporting server v4
www-945.ibm.com	129.42.34.224	443	Problem reporting server v4
www-945.ibm.com	129.42.42.224	443	Problem reporting server v4
www.ibm.com	129.42.56.216	80, 443	Service provider file (CCF) download
www.ibm.com	129.42.58.216	80, 443	Service provider file (CCF) download
www.ibm.com	129.42.60.216	80, 443	Service provider file (CCF) download
www-03.ibm.com	204.146.30.17	80, 443	Service provider file (CCF) download

Table 9. CIDR subnet mask information

Subnet Mask	CIDR Equivalent	Note
255.255.255.255	/32	Host (single address)
255.255.255.254	/31	Unusable
255.255.255.252	/30	2 usable
255.255.255.248	/29	6 usable

Table 9. CIDR subnet mask information (continued)

Subnet Mask	CIDR Equivalent	Note
255.255.255.240	/28	14 usable
255.255.255.224	/27	30 usable
255.255.255.192	/26	62 usable
255.255.255.128	/25	126 usable
255.255.255.0	/24	Class C 254 usable
255.255.254.0	/23	2 Class Cs
255.255.252.0	/22	4 Class Cs
255.255.248.0	/21	8 Class Cs
255.255.240.0	/20	16 Class Cs
255.255.224.0	/19	32 Class Cs
255.255.192.0	/18	64 Class Cs
255.255.128.0	/17	128 Class Cs
255.255.0.0	/16	Class B
255.254.0.0	/15	2 Class Bs
255.252.0.0	/14	4 Class Bs
255.248.0.0	/13	8 Class Bs
255.240.0.0	/12	16 Class Bs
255.224.0.0	/11	32 Class Bs
255.192.0.0	/10	64 Class Bs
255.128.0.0	/9	128 Class Bs
255.0.0.0	/8	Class A
254.0.0.0	/7	2 Class As
254.0.0.0	/6	4 Class As
252.0.0.0	/5	2 Class As
248.0.0.0	/4	8 Class As
224.0.0.0	/3	16 Class As
192.0.0.0	/2	32 Class As
128.0.0.0	/1	64 Class As
0.0.0.0	/0	IP space

Authentication Method Decision Tree:

The Storwize V7000 Unified systems require one, and only one, authentication system to allow network users to access file systems or file sets exported (shared) by the Storwize V7000 Unified system. The authentication system may also be used to provide User ID mapping. Several authentication methods are supported. They are:

- Microsoft Active Directory - with or without SUA / SFU
- Lightweight Directory Access Protocol (LDAP)
- Network Information Service (NIS)

A local LDAP server can also be used which runs on the file modules, but this is limited. For example it does not support asynchronous filesystem replication to another Storwize V7000 Unified system. Refer to Managing authentication and ID mapping, located in the Information Center.

Use the flow chart in Figure 18 to assist in deciding which authentication method is right for you. The factors that influence the decision are the types of client hosts, the existing authentication infrastructure (if any), and if asynchronous file system replication is to be utilized.

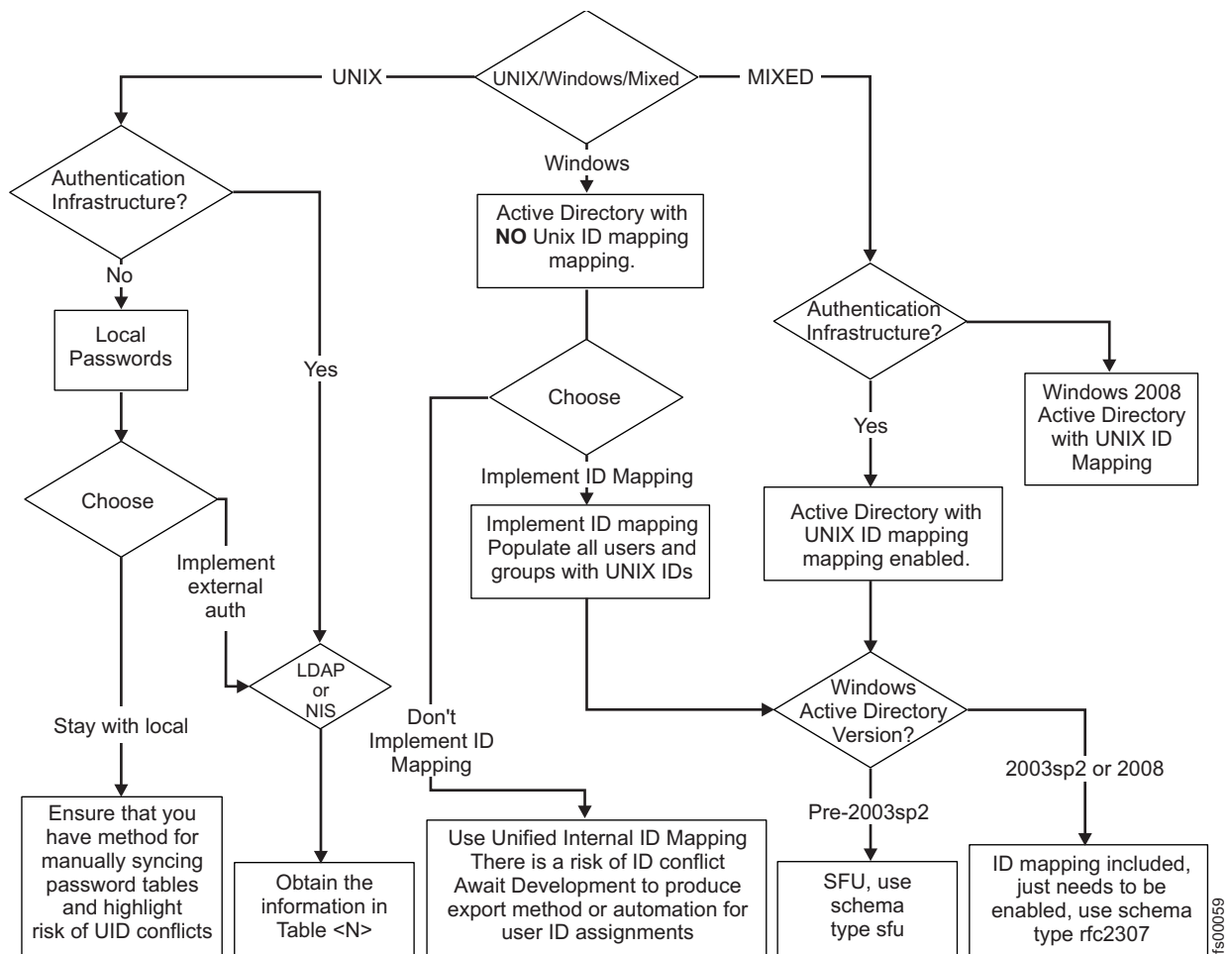

Figure 18. Planning chart for determining an authentication method

Internally, the Storwize V7000 Unified system uses IBM General Parallel File System (GPFS). GPFS is a UNIX file system that uses UNIX-style user IDs (UID) and group IDs (GID) to manage file permissions.

For Windows (CIFS) users to access files, there must be some sort of User ID Mapping, such as some way to map the Windows user and group objects to Unix UIDs and GIDs. The Storwize V7000 Unified system supports user ID mapping either internally or externally. While external user ID mapping is preferred, internal mapping can be done using a table local to the Storwize V7000 Unified system to map Windows user and group objects to arbitrary Unix UIDs and GIDs. That table is not accessible externally, even to another Storwize V7000 Unified system for asynchronous file system replication.

Asynchronous replication thus requires external user ID mapping, specifically Windows Active Directory with the Subsystem for Unix (SUA) enabled and populated. Mixed client access, which is having both UNIX and Windows clients access the same files (using NFS and CIFS), requires external user mapping using either Active Directory with SUA/SFU or LDAP with Samba extensions.

Table 10. Authentication method information

Field	Value	Note
Authentication Method	<input type="checkbox"/> Microsoft Active Directory <input type="checkbox"/> Lightweight Directory Access Protocol (LDAP) <input type="checkbox"/> Samba Primary Domain Controller (PDC) - NT4 <input type="checkbox"/> None (requires configuring Network Information Service (NIS) for NFS NetGroup support)	Check one of the options. If you check None , do not select either of the following NIS options.
Options	<input type="checkbox"/> Kerberos, compatible with authentication method of LDAP only <input type="checkbox"/> Services For UNIX (SFU) - compatible with authentication method of Active Directory only <input type="checkbox"/> Network Information Service (NIS) - NFS NetGroup support without User ID Mapping - compatible with authentication method of Active Directory or PDC only. <input type="checkbox"/> Network Information Service (NIS) - NFS NetGroup support authentication method with User ID Mapping - compatible with authentication method of Active Directory or PDC only.	One or more of these optional capabilities may be used to extend the capabilities of the authentication method selected previously. If none of these options are needed then leave this row blank.

If you checked Microsoft Active Directory in the **Authentication Method** field of Table 10, you must complete Table 11.

Table 11. Active Directory configuration information

Field	Value	Note
Active Directory Server Ip Address	_____ _____	This is the numeric IP address of the remote Active Directory server (domain controller) on your network.
Active Directory Userid		This is the user ID that must be provided when communicating with the remote Active Directory server. The following user ID and the password are used to authenticate to the Active Directory server.

Table 11. Active Directory configuration information (continued)

Field	Value	Note
Active Directory Password		This is the password that must be provided when communicating with the remote Active Directory server.
SFU DOMAIN NAME		<p>If you checked Services For Unix (SFU) in the Options field of Table 10 on page 24, then you must complete this field. If you did not check SFU, leave this field blank.</p> <p>This field is used to specify the Trusted Domain Name for the Active Directory server.</p>
SFU RANGE	Upper range: _____ Lower range: _____	<p>If you checked Services For Unix (Sfu) in the Options field of Table 10 on page 24, then you must complete this field. If you did not check SFU, leave this field blank.</p> <p>This field is used to specify the Lower and Upper bounds of the User Identifier (UID) and Group Identifier (GID) ranges for the storage system. Use the format Lower-Upper (for example, 25-37).</p> <p>The SFU Range must contain the UNIX UID/GID numbers corresponding to users/groups who need to access the system with SFU.</p> <p>The primary group assigned to the SFU users must be an existing Active Directory group with a valid UNIX GID assigned to it. The SFU users must have the same UNIX Attribute primary group and Windows primary group.</p> <p>The UNIX UID/GID that are assigned to such users/groups must be in the ID range provided with -cp parameter of the cfgsfu command. The range for UID/GID must not intersect with 10000000-11000000, this range is used by Scale Out Network Attached Storage internally for other UID/GID mapping</p>
SFU SCHEMA MODE	<input type="checkbox"/> SFU <input type="checkbox"/> rfc2307	<p>If you checked Services For Unix (Sfu) in the Options field of Table 10 on page 24, then you must complete this field. If you did not check SFU, leave this field blank.</p> <p>This field is used to specify the schema Mode. The schema Mode can be either sfu or rfc2307 depending on the operating system of the Active Directory domain server. If the operating system of the domain server is Microsoft Windows 2008 or Windows 2003 with SP2R2 packages use the schemaMode of rfc2307 for Windows 2000 and Windows 2003 with SP1, use sfu.</p>

If you checked **LDAP** in the **Authentication Method** field of Table 10 on page 24, you must complete Table 12 on page 26.

Table 12. LDAP configuration information

Field	Value	Note
LDAP SERVER IP ADDRESS	____.____.____.____ ____.____.____.____	This is the numeric IP address of the remote LDAP server on your network.
SECURITY METHOD	<input type="checkbox"/> Off <input type="checkbox"/> SSL (Secure Sockets Layer) <input type="checkbox"/> TLS (Transport Layer Security)	<p>The communications link between the Storwize V7000 Unified system and your LDAP server may be open (unencrypted), or may be secured (encrypted). If secured, one of two methods is used: SSL or TLS.</p> <p>Note: When SSL or TLS is used, a security certificate file must be copied from your LDAP server to the Storwize V7000 Unified Management Node.</p>
Certificate Path		<p>If the SSL method is Off, leave this field blank.</p> <p>If the SSL method is SSL or TLS, record the path on the Storwize V7000 Unified Management Node where you copy the Certificate file. As an example, if the Certificate File is cacert.pem and you store it in a directory called /certificates, then record /certificates/cacert.pem.</p>
User Suffix		Specifies the LDAP user suffix to be used.
Group Suffix		Specifies the LDAP group suffix to be used.
Bind Distinguished Name		<p>This is the bind distinguished name from the /etc/openldap/slapd.conf file on your LDAP server. In the example following note 1 below, the bind distinguished name is cn=Manager,dc=v7kuldap,dc=com</p>
Bind Password		<p>This is the bind password from the /etc/openldap/slapd.conf file on your LDAP server. In the example following note 1 below, the bind password is secret.</p>
Kerberos Server Name		<p>If you checked Kerberos in the Options field of Table 10 on page 24, you must complete this field. If you did not check Kerberos, leave this field blank. This field is the name of the Kerberos server used with your LDAP environment.</p>
Kerberos Realm		<p>If you checked Kerberos in the Options field of Table 10 on page 24, then you must complete this field. If you did not check Kerberos, leave this field blank. This field is the Realm for the Kerberos server used with your LDAP environment.</p>
Kerberos Keytab File		<p>If you checked Kerberos in the Options field of Table 10 on page 24, then you must complete this field. If you did not check Kerberos, leave this field blank. This field is the file name for the Kerberos KeyTab file.</p>

Table 13. NIS configuration information

Field	Value	Note
NIS MODE	<p><input type="checkbox"/> Basic - NIS is used (to provide NFS NetGroup support) in an environment without Active Directory, LDAP, or Samba Primary Domain Controller (PDC).</p> <p><input type="checkbox"/> Extended - NIS is used (to provide NFS NetGroup support or to map UNIX IDs to Windows IDs) for an environment where Active Directory or Samba Primary Domain Controller (PDC) is used for Authentication.</p>	<p>NIS is typically used for one of the following purposes:</p> <ul style="list-style-type: none"> • NIS can be used to provide NFS Netgroup support in an environment without Active Directory, LDAP, or PDC. • NIS can be used to provide NFS Netgroup support in an environment with Active Directory, or PDC. • NIS can be used to provide NFS NetGroup support and map UNIX user IDs (which are numeric) to Windows user IDs (which are text strings), allowing UNIX servers to access Network Attached Storage devices that use Microsoft Active Directory or PDC to authenticate users. <p>If you checked None in the Authentication Method field of Table 10 on page 24, then select Basic.</p> <p>If you checked either of the NIS items in the Options field of Table 10 on page 24, then select Extended.</p>
Domain Map		<p>If the NIS Mode is Basic, leave this field blank.</p> <p>If the NIS mode is Extended, this field is optional.</p> <p>This field can be used to specify the mapping between Active Directory domains and different NIS domains.</p> <p>When specifying a domain map, use a colon between the Active Directory domain and the NIS domain or domains. Example: ad_domain:nis_domain1</p> <p>If more than one NIS domain is specified, use a comma-separated list. Example: ad_domain:nis_domain1,nis_domain2</p> <p>To specify more than one Active Directory domain, use a semicolon. Example: ad_domain1:nis_domain1,nis_domain2; ad_domain2:nis_domain3,nis_domain4</p>

Table 13. NIS configuration information (continued)

Field	Value	Note
Server Map		<p>This field must be used to specify the mapping between NIS servers and NIS domains.</p> <p>When specifying a server map, use a colon between the NIS server and the NIS domain or domains. Example: nis_server:nis_domain1</p> <p>If more than one NIS domain is specified, use a comma-separated list. Example: nis_server:nis_domain1,nis_domain2</p> <p>To specify more than one NIS server, use a semicolon. Example: nis_server1:nis_domain1,nis_domain2; nis_server2:nis_domain3,nis_domain4</p>
User Map		<p>If the NIS Mode is Basic, leave this field blank.</p> <p>This optional field can be used to specify the handling for a user who is not known to the NIS server. Only one rule can be specified for each Active Directory or PDC domain.</p> <p>The handling is specified using one of the following keywords:</p> <ul style="list-style-type: none"> • DENY_ACCESS - denies any user from the specified domain access if they do not have a mapping entry in the NIS. Example: ad_domain1:DENY_ACCESS • AUTO - a new ID for the user is generated from the specific domain which does not have an entry in the NIS. This ID is generated from a pre-specified ID range and is auto-incremented. The administrator must make sure that existing NIS IDs do not fall in this provided ID range. This mapping is kept in Scale Out Network Attached Storage and NIS is not aware of this ID mapping. The ID range can be specified using the ID Map User Range and ID Map Group Range options. Example: ad_domain1:AUTO • DEFAULT - any user from the specified domain who does not have a mapping entry in the NIS server is mapped to a specified user (typically a guest user). Example: ad_domain1:DEFAULT:ad_domain\guest <p>To specify rules for multiple Active Directory or PDC domains, separate the rules with a semicolon. Example: ad_domain1:DENY_ACCESS; ad_domain2:AUTO; ad_domain3:DEFAULT:ad_domain3\guest</p>
NIS DOMAIN		<p>This field must be used to specify the NIS Domain that is stored in the registry.</p>

Table 13. NIS configuration information (continued)

Field	Value	Note
Use Id Map	[] Use ID Map - NIS is used to map UNIX IDs to Windows IDs for an environment where Active Directory or Samba Primary Domain Controller (PDC) is used for Authentication.	If the NIS Mode is Basic, leave this field blank. If you checked NIS - NFS NetGroup support without User ID Mapping in the Options field of Table 10 on page 24, leave this field blank. If you checked NIS - NFS NetGroup support with User ID Mapping in the Options field of Table 10 on page 24, then check the Use ID Map field.
ID MAP USER RANGE		If the Use ID Map field is blank, leave this field blank. If the Use ID Map field is checked AND at least one User Map rule is AUTO then you must specify a User Range and/or a Group Range. Example: 10000-20000. Note: The User Range values must be a minimum of 1024.
ID MAP GROUP RANGE		If the Use ID Map field is blank, leave this field blank. If the Use ID Map field is checked AND at least one User Map rule is AUTO then you must specify a User Range and/or a Group Range. Example: 30000-40000. Note: The Group Range values must be a minimum of 1024.

Chapter 2. Installing the hardware

Install the hardware components and connect the data cables and power cords.

You have completed the initial steps of verifying the shipping contents and becoming familiar with the hardware components. You have verified that the power and environmental requirements are met and have planned the location of the enclosures and file modules. You are now ready to begin installing the hardware components and connecting the data cables and power cords.

Step 6. Installing the support rails for the enclosures

Install the support rails for the enclosures in the rack.

About this task

Review the documentation that comes with the rack cabinet for safety and cabling information. Before you install the control enclosure in a rack cabinet, review the following guidelines

- Two or more people are required to install devices 2U or larger in a rack cabinet.
- Make sure that the room air temperature is below 35°C (95°F).
- Do not block any air vents; usually 15 cm (6 inch) of space provides proper airflow.
- Do not leave open spaces above or below an installed control enclosure in the rack cabinet. To help prevent damage to control enclosure components, always install a blank filler panel to cover the open space and to help ensure proper air circulation. Install the control enclosure only in a rack cabinet with perforated doors.
- Plan the device installation starting from the bottom of the rack cabinet.
- Install the heaviest device in the bottom of the rack cabinet.
- Do not extend more than one device out of the rack cabinet at the same time.
- Remove the rack doors and side panels to provide easier access during installation.
- Connect the control enclosure to a properly grounded outlet.
- Do not overload the power outlet when you install multiple devices in the rack cabinet.
- Install the control enclosure in a rack that meets the following requirements:
 - Minimum depth of 70 mm (2.76 inch) between the front mounting flange and inside of the front door.
 - Minimum depth of 157 mm (6.18 inch) between the rear mounting flange and inside of the rear door.



Figure 19. Securing an enclosure to a rack cabinet

- Minimum depth of 718 mm (28.27 inch) and maximum depth of 762 mm (30 inch) between the front and rear mounting flanges to support the use of the cable management arm.

To install the support rails, follow these steps:

1. Locate the rack mounting rails and screws.

The rail assembly is made up of two sets of rails. One set of rails is already installed, or preinstalled, on the sides of the enclosures. The other set of rails must be installed in the rack cabinet. The rails on the sides of the enclosures slide into the rails that are installed in the rack cabinet.

2. Working at the front of the rack cabinet, identify the two standard rack units of space in the rack into which you want to install the support rails.

Figure 20 on page 33 shows two rack units with the front mounting holes identified.

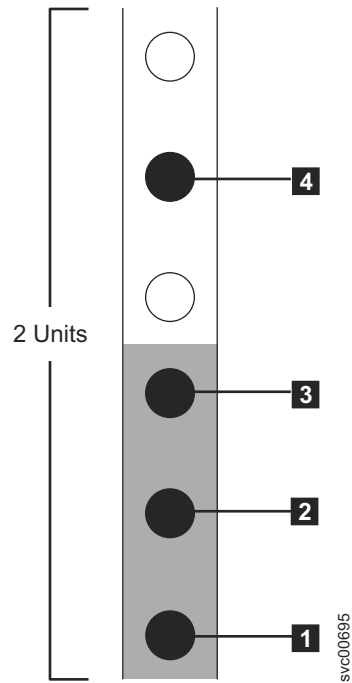

Figure 20. Hole locations in the front of the rack

- **1** Bottom rail location pin hole
 - **2** Enclosure mounting screw hole. Do not insert the screw until the enclosure is installed.
 - **3** Rack mounting screw hole
 - **4** Top rail location pin hole
3. Align the bottom of the rail with the bottom of the two rack units. Insert the rail location pins **1** and **4** through the holes in the rack cabinet.
 4. Insert a clamping screw into the rack mounting hole **3** between the rail location pins.
 5. Tighten the screw to secure the rail to the rack.
 6. Working from the rear of the rack cabinet, extend the rail that you secured to the front to align the bottom of the rail with the bottom of the two rack units.

Note: Ensure that the rail is level between the front and the back.

Figure 21 on page 34 shows two rack units with the back mounting holes identified.

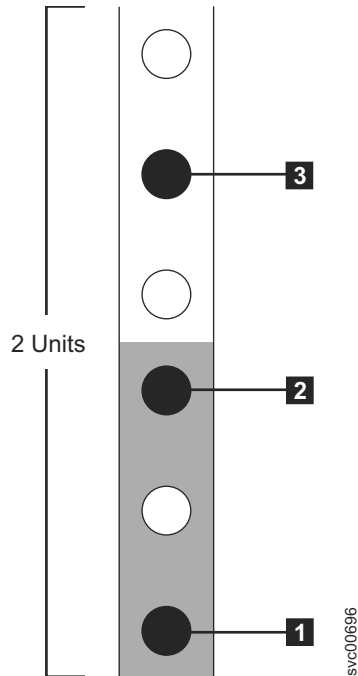

Figure 21. Hole locations in the back of the rack

- **1** Bottom rail location pin hole
- **2** Rack mounting screw hole
- **3** Top rail location pin hole

7. Insert the rail location pins through the holes **1** and **3** in the rack cabinet.
8. Insert a clamping screw into the rack mounting hole **2** between the rail location pins.
9. Tighten the screw to secure the rail to the rack from the back side.
10. Repeat the steps to secure the opposite rail to the rack cabinet.
11. Repeat the procedure for each additional enclosure.

Step 7. Installing the enclosures

Install the enclosures making sure you follow the safety guidelines.

About this task

CAUTION:

The weight of this part or unit is between 18 and 32 kg (39.7 and 70.5 lb). It takes two persons to safely lift this part or unit. (C009)

DANGER

Observe the following precautions when working on or around your IT rack system:

- Heavy equipment—personal injury or equipment damage might result if mishandled.
- Always lower the leveling pads on the rack cabinet.
- Always install stabilizer brackets on the rack cabinet.
- To avoid hazardous conditions due to uneven mechanical loading, always install the heaviest devices in the bottom of the rack cabinet. Always install servers and optional devices starting from the bottom of the rack cabinet.
- Rack-mounted devices are not to be used as shelves or work spaces. Do not place objects on top of rack-mounted devices.



- Each rack cabinet might have more than one power cord. Be sure to disconnect all power cords in the rack cabinet when directed to disconnect power during servicing.
- Connect all devices installed in a rack cabinet to power devices installed in the same rack cabinet. Do not plug a power cord from a device installed in one rack cabinet into a power device installed in a different rack cabinet.
- An electrical outlet that is not correctly wired could place hazardous voltage on the metal parts of the system or the devices that attach to the system. It is the responsibility of the customer to ensure that the outlet is correctly wired and grounded to prevent an electrical shock.

(R001 part 1 of 2)

Following your enclosure location plan, install the correct type of enclosure starting from the bottom.

1. On either side of the drive assemblies, remove the enclosure end caps by squeezing the middle of the cap and pulling it away from the front of the enclosure. Figure 22 on page 36 shows how to remove the enclosure end cap.



Figure 22. Removing the enclosure end cap

2. Align the enclosure with the front of the rack cabinet.
3. Carefully slide the enclosure into the rack along the rails until the enclosure is fully inserted.

Notes:

- a. The preinstalled rails on the sides of the enclosure must fit into the rack-mounted rails that you previously installed.
 - b. The rails are not designed to hold an enclosure that is partially inserted. The enclosure must always be in a fully inserted position.
 - c. Do not have more than one enclosure extended out of the rack at the same time to avoid the danger of the rack toppling over.
4. Insert a screw into the hole behind each enclosure end cap and tighten the screw, as shown in Figure 23 on page 37.

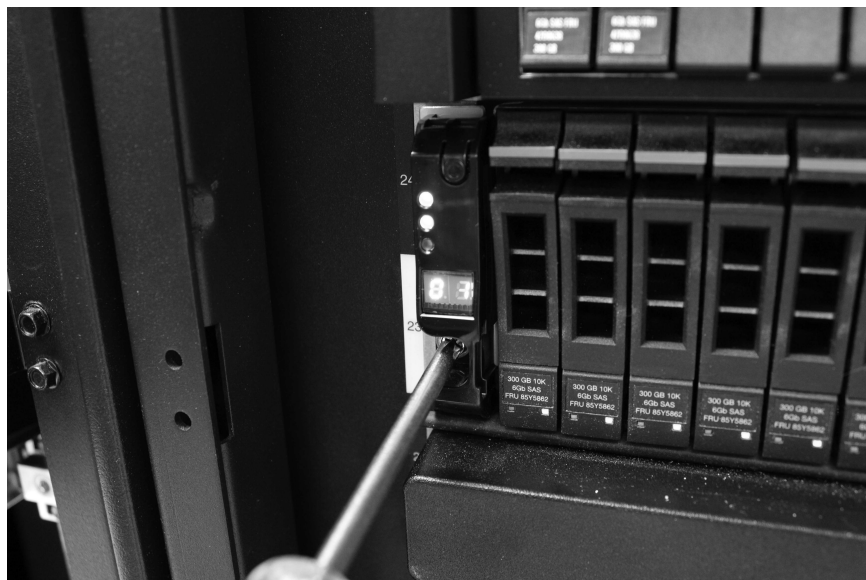

Figure 23. Securing an enclosure to a rack cabinet

5. After matching each end cap's serial number to the serial number found on the rear of each enclosure, push the end caps back into position.
6. Repeat this procedure for each additional enclosure that you install.

Step 8. Installing the support rails for file module slides

Before installing the file module, you must install support rails in the rack.

Before you begin

Review the documentation that comes with the rack cabinet for safety and cabling information. Before you install the file module in a rack cabinet, review the following guidelines:

- Two or more people are required to install devices 2U or larger in a rack cabinet.
- Make sure that the room air temperature is below 35°C (95°F).
- Do not block any air vents; usually 15 cm (6 inch) of space provides proper airflow.
- Do not leave open spaces above or below an installed file module in the rack cabinet. To help prevent damage to file module components, always install a blank filler panel to cover the open space and to help ensure proper air circulation.
- Install the file module only in a rack cabinet with perforated doors.
- Plan the device installation starting from the bottom of the rack cabinet.
- Install the heaviest device in the bottom of the rack cabinet.
- Do not extend more than one device out of the rack cabinet at the same time.
- Remove the rack doors and side panels to provide easier access during installation.
- Do not overload the power outlet when you install multiple devices in the rack cabinet.
- Install the file module in a rack that meets the following requirements:

- Minimum depth of 70 mm (2.76 inch) between the front mounting flange and inside of the front door.
- Minimum depth of 157 mm (6.18 inch) between the rear mounting flange and inside of the rear door.
- Minimum depth of 718 mm (28.27 inch) and maximum depth of 762 mm (30 inch) between the front and rear mounting flanges to support the use of the cable management arm.

Note: The maximum distance between the front and the rear EIA rails of the rack is 810 mm (31.9 inch). Also, cage nuts and clip nuts are not required to install the file module in a rack cabinet.

- Install the cable management arm on either side of the file module. These instructions are shown with the cable management arm mounted on the left side. The installation instructions in this document can be reversed if you are installing the cable management arm on the side of the file module not shown.

Figure 24 shows the items that you need to install the file module in the rack cabinet. If any items are missing or damaged, contact your place of purchase. The contents from the slide rail box and the cable management arm box are necessary for this installation.

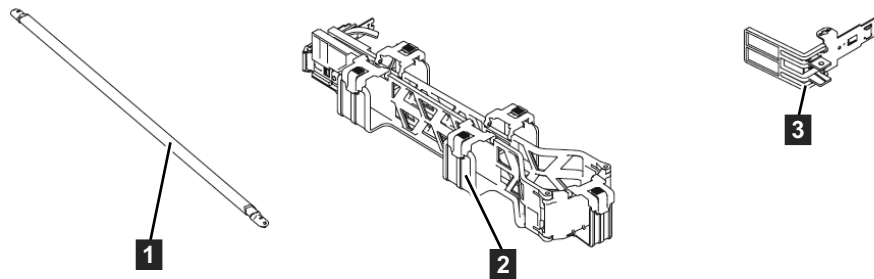

svc00884

Figure 24. Cable management arm box contents

- 1** Cable-management support bar
- 2** Cable-management arm assembly
- 3** Cable-management stop bracket

Figure 25 on page 39 shows the friction rail box contents.

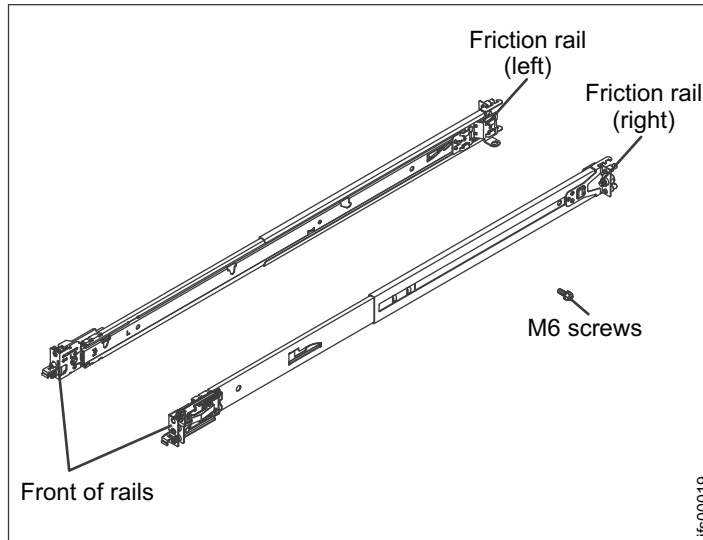

Figure 25. Friction rail box contents

Procedure

To install the support rails, complete the following steps.

1. If the slide rails in your rack installation kit came with shipping thumbscrews, remove them.
2. Select an available 2U space in the rack to install the file modules. Refer to Figure 26.

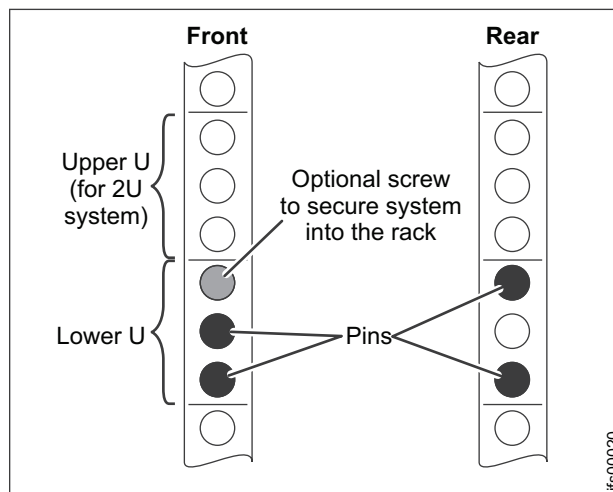

Figure 26. Locate a 2U space in the lower section of the rack.

3. Each slide rail is marked with either an R (right) or an L (left). Select one of the slide rails and pull the rear bracket all the way back. If a thumbscrew is installed in the slide rail, remove it. Refer to Figure 27 on page 40.

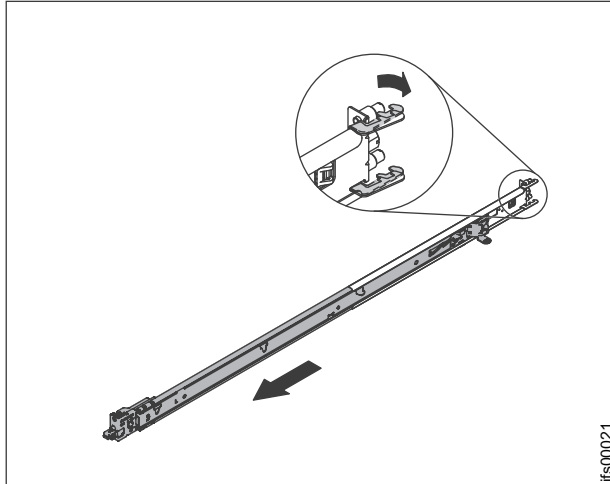

Figure 27. Opening the rear slide rail hooks

Note: If you are installing the slide rails into a 1U space with devices already installed directly above and below this 1U space, you need to extend the slide rails to slide the rear of the slide rails into the rear of the rack. When installing a 2U device, be sure to install the slide rails in the bottom position of the 2U area in the rack.

4. From the front of the rack, line up the two pins on the rear of the slide rail in the selected unit on the rear of the rack. Push the rails so that the pins go into the holes and slide the rails into the rack to lock the rear of the slide rails into the rack. Refer to Figure 28.

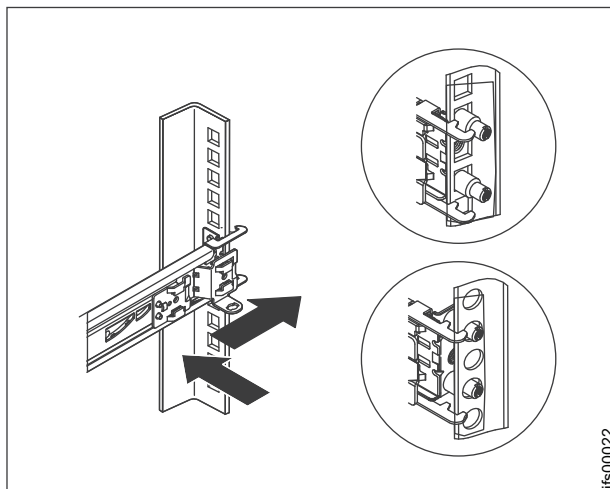

Figure 28. Installing the rear end of the slide rails

5. Push the blue button to allow the latch to slide forward, as shown in Figure 29 on page 41.

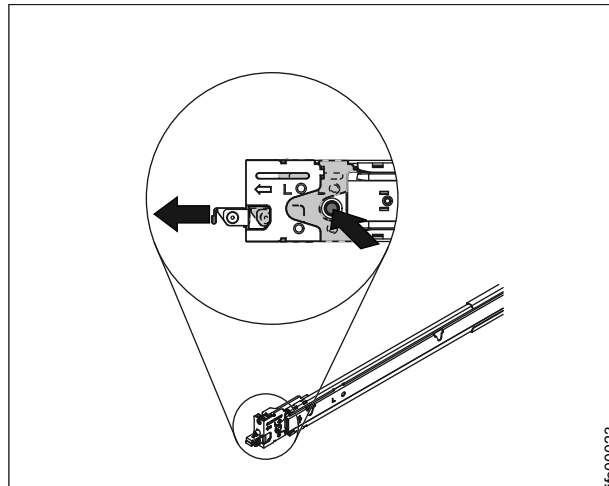

Figure 29. Install the rear end of the slide rails

6. Pull the slide rail forward and locate the front latch in the appropriate unit space in front of the rack EIA rail. Adjust the length of the rail.
7. Press the blue button to release the bracket. Push the front latch in all the way. Make sure the latch is fully engaged. Refer to Figure 30.
8. Repeat this procedure to install the other rail into the rack. Make sure that each front latch is fully engaged.

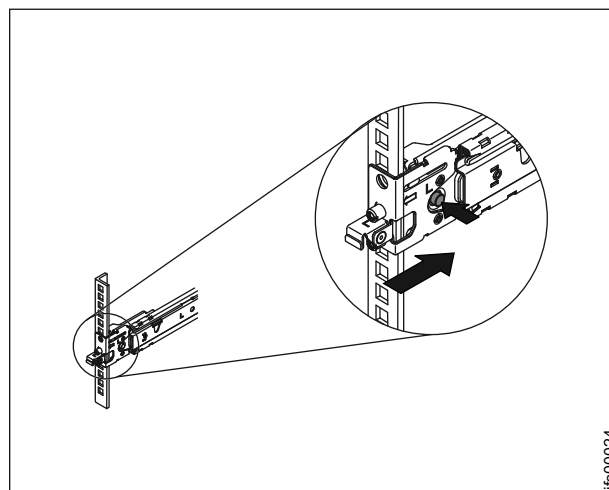

Figure 30. Install the front end of the slide rails.

Step 9. Installing the file modules

Install the file modules in the rack following the safety guidelines.

About this task

To install each file module in the rack, follow these instructions.

Procedure

1. Pull the slide rails forward **1** until they click, two times, into place as shown in Figure 31 on page 42. Carefully lift the file module and tilt it into position

over the slide rails so that the rear nail heads **2** on the device line up with the slide rails. Slide the file module down until the rear nail heads slip into the two rear slots, and then slowly lower the front of the file module **3** until the other nail heads slip into the other slots on the slide rails. See Figure 31.

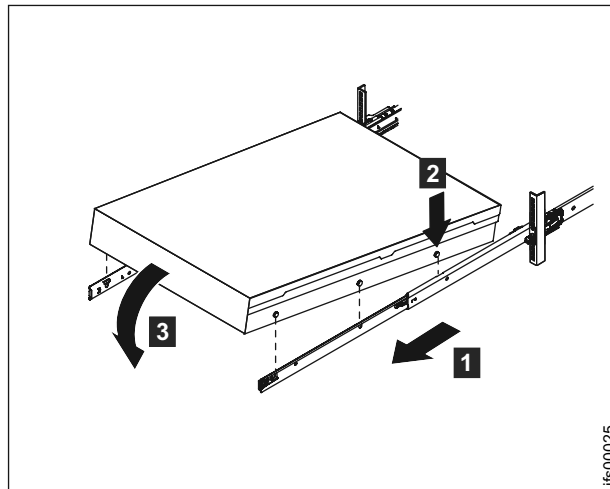

Figure 31. Installing the file module on the slide rails.

2. Lift the locking levers **1** on the slide rails and push the file module **2** all the way into the rack until it clicks into place. Refer to Figure 32.

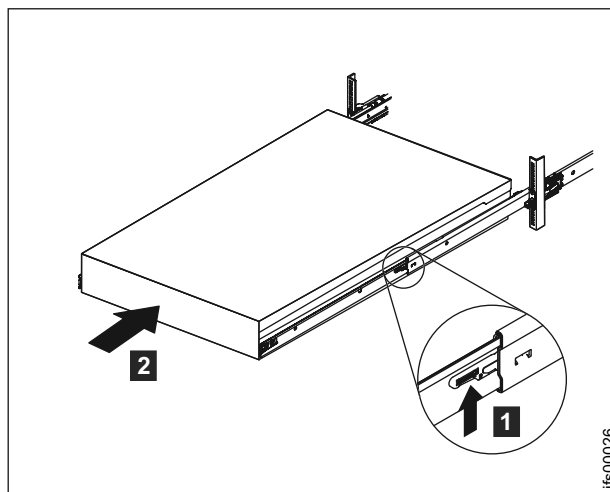
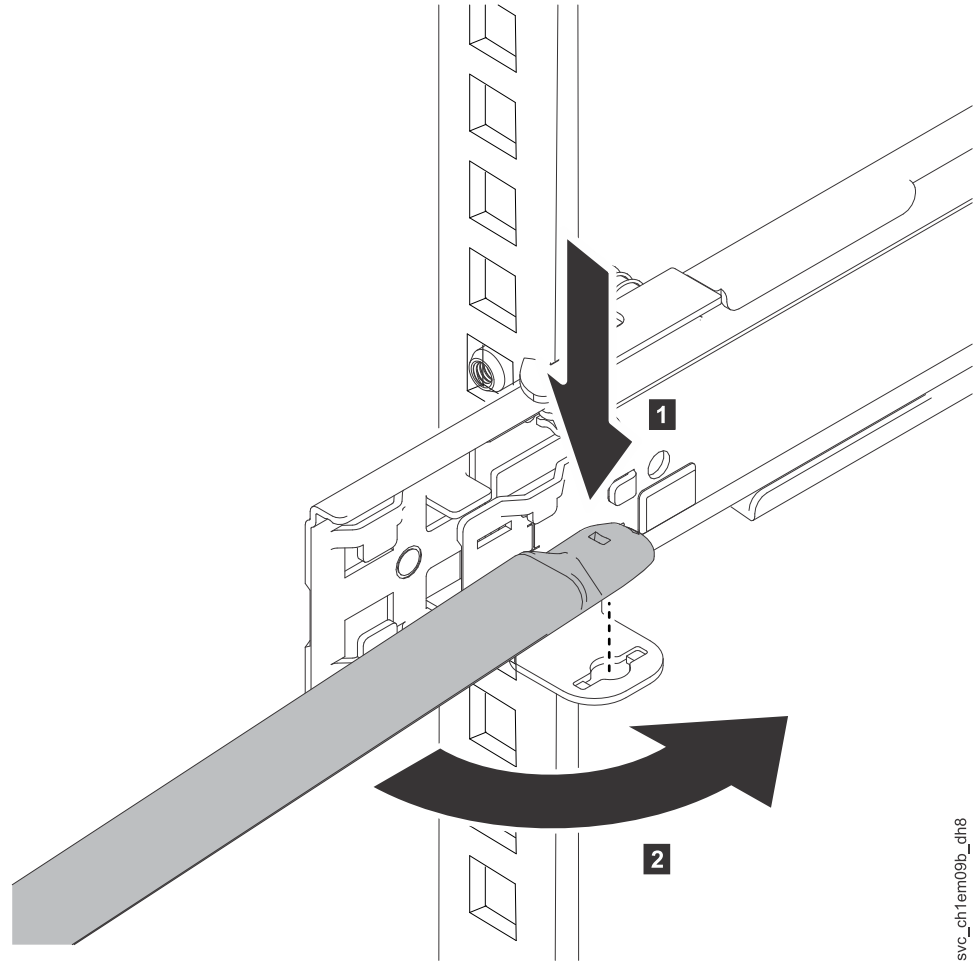

Figure 32. Sliding the file module into the rack.

3. Install the cable management support bar on the left-rear side of the node, as shown in Figure 33 on page 43.
 - a. Connect one end of the support bar to the same slide rail to which you plan to attach the cable management arm assembly.
 - b. Swing the other end of the support bar toward the rack.



svc_ch1em09b_dth8

Figure 33. Installing the cable-management support bar

4. Connect the other end of the support bar to the stop bracket, as shown in Figure 34 on page 44.

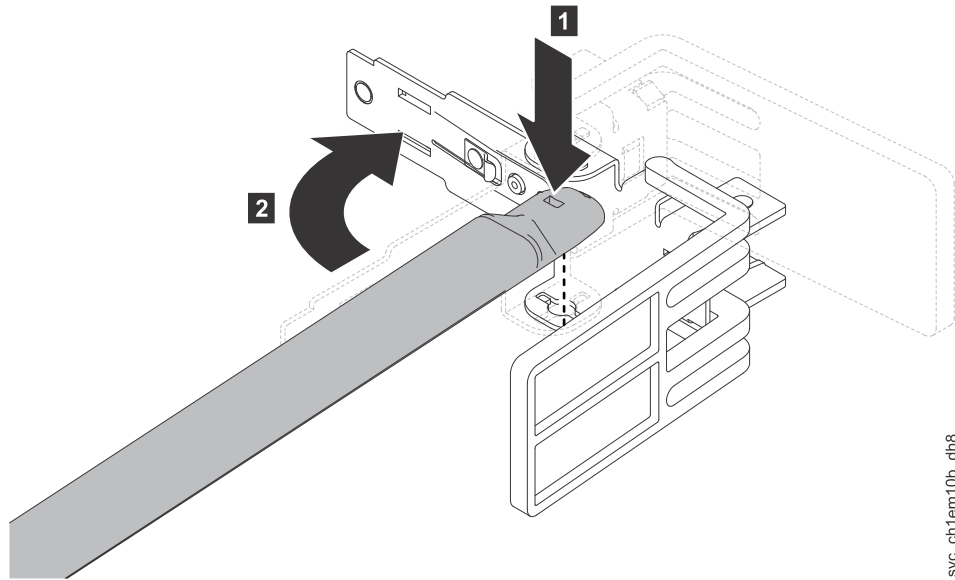

Figure 34. Connecting the cable management support bar to the stop bracket

5. Connect the stop bracket to the slide rail, as shown in Figure 35 on page 45.
 - a. The capital letters I and O are printed on cable management arm pins to identify the inside and outside pins.
 - b. Install the stop bracket (with capital letter O) on the unattached end of the support bar.
 - c. Verify that the support bar is securely installed.

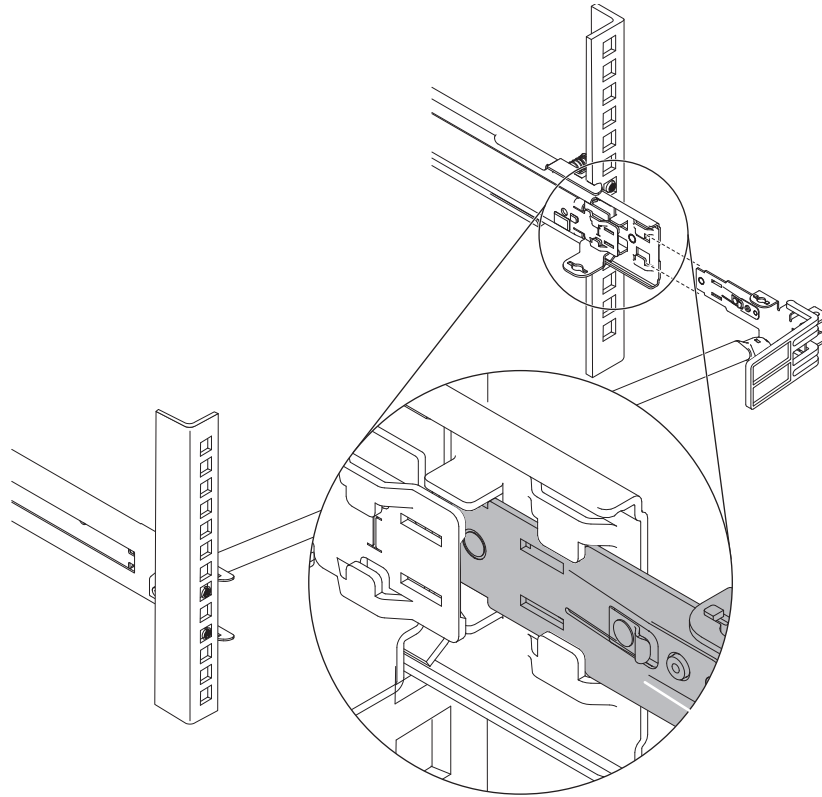

Figure 35. Connecting the stop bracket to the slide rail

6. Install the cable management arm as shown in Figure 36 on page 46.
 - a. Place the cable management arm on the support bar.
 - b. Pull out both the inside and the outside pins of the cable management arm.
 - c. Slide the cable management arm tabs into both the inside and the outside slots of the slide rail.
 - d. Push the tabs until they snap into place.

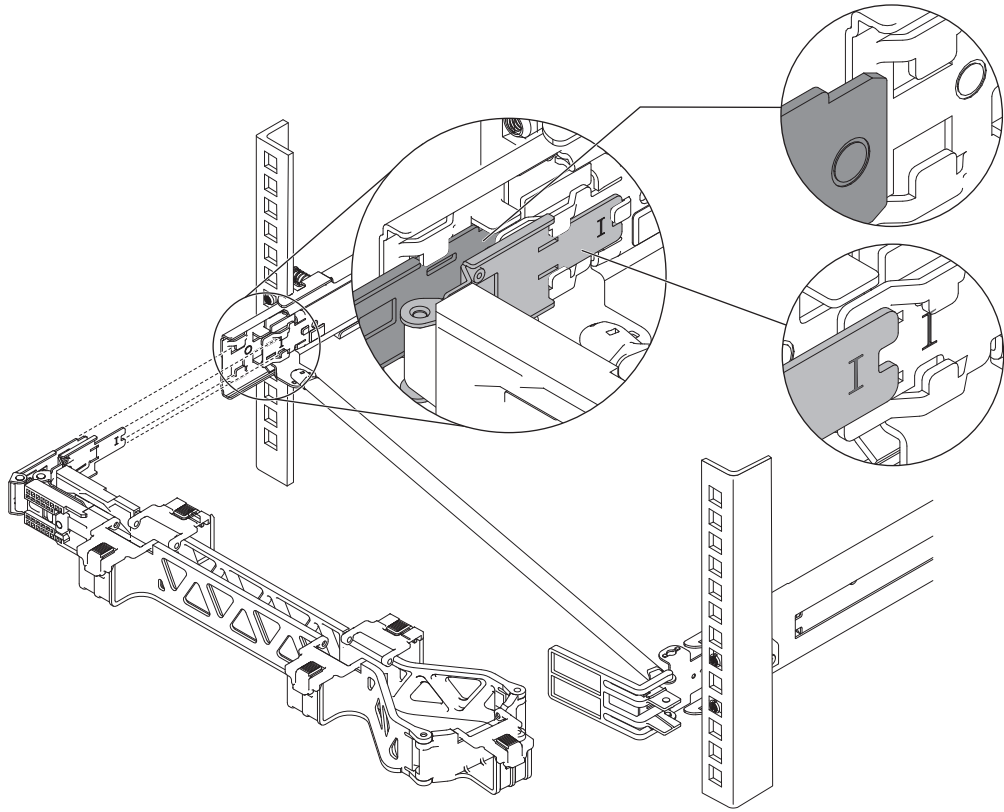

Figure 36. Installing the cable management arm

7. Close the stop bracket as shown in Figure 37 on page 47.
 - a. Open the stop bracket, which makes rotating the cable management arm on and off the support bar easier.
 - b. Push the tabs above and below the stop bracket to close it.

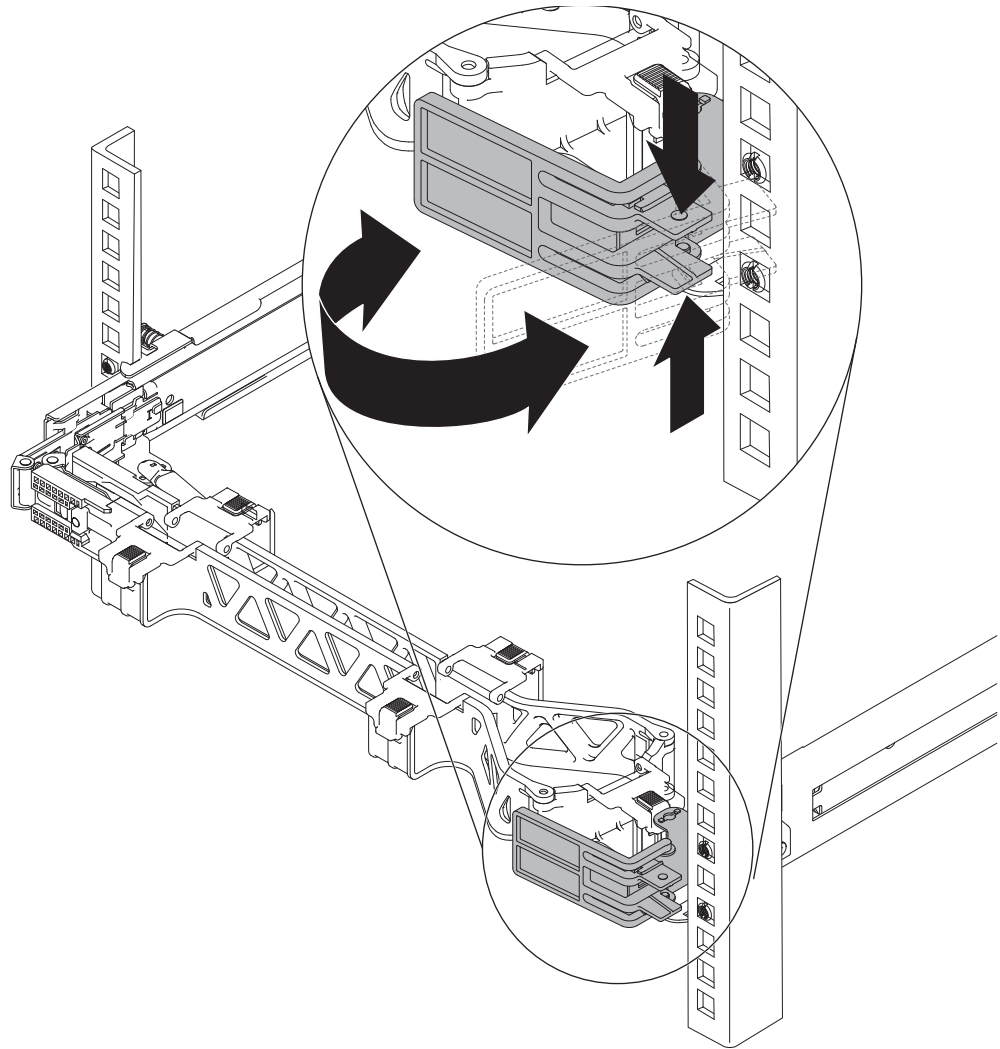

Figure 37. Closing the stop bracket

8. Connect and route the cables as shown in Figure 38 on page 48.
 - a. Connect the power cords and other cables to the rear of the node.
 - b. Route the cables and power cords on the cable management arm and secure them with cable ties or hook-and-loop fasteners.

Note:

- The location of the cable straps can vary in different systems.
- Use the cable straps that are provided on the rear of the system to retain the cables and prevent them from sagging.

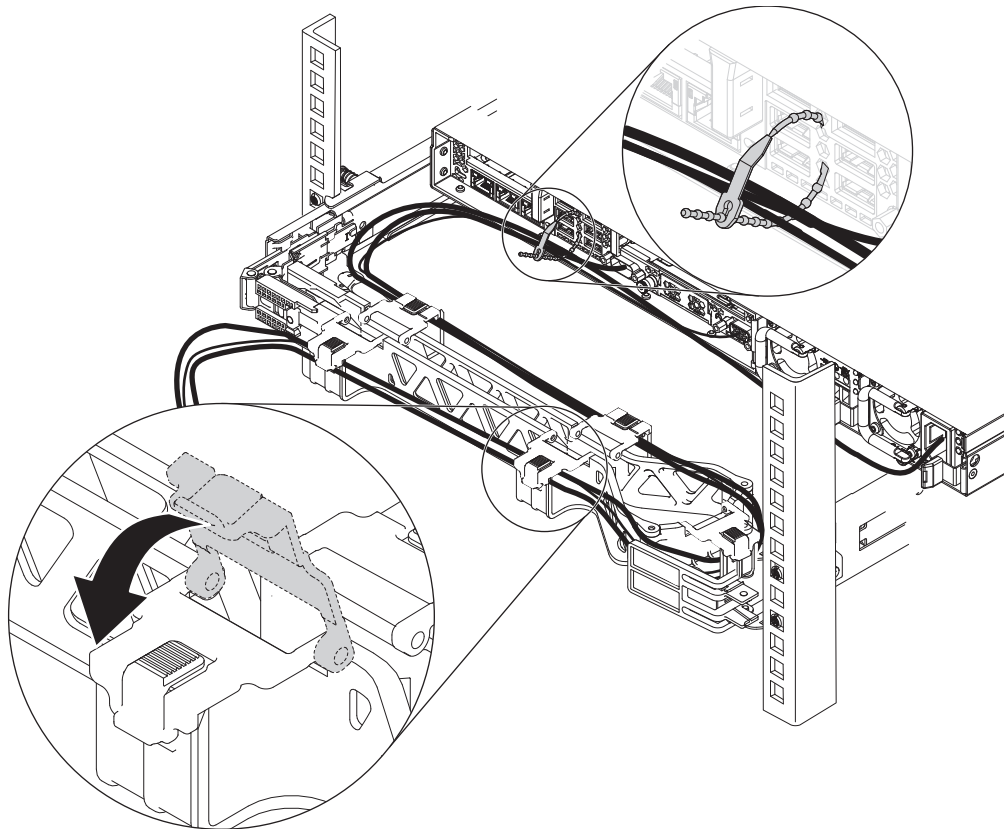

Figure 38. Connecting and routing the cables

9. Secure the cables with the hook-and-loop fastener strap, as shown in Figure 39 on page 49.

Note:

- Cables must be bundled with the hook-and-loop fastener strap to ensure full range of movement of the cable management arm.
- Make sure that the cables do not sag below the U space so they cannot interfere with the lower systems.
- Allow slack in all cables to avoid tension in the cables as the cable management arm moves.

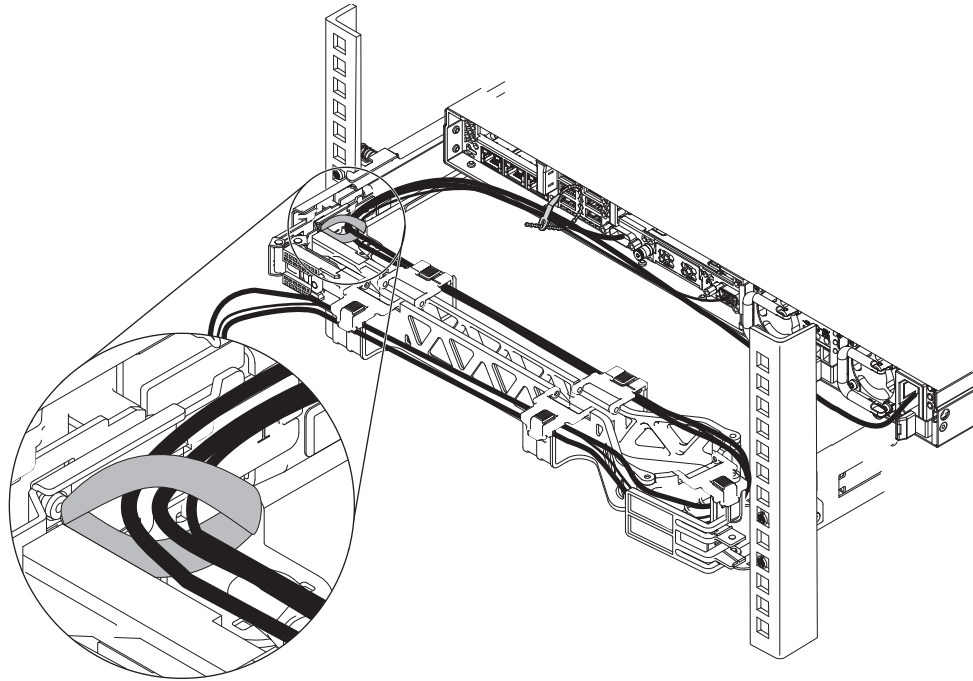

Figure 39. Securing the cables with hook-and-loop fastener strap

10. Optional: You can install the cable management arm assembly on the opposite side, as shown in Figure 40 on page 50.
 - a. Press the release buttons **1** and slide the mounting brackets **2** out of the cable management arm.
 - b. Rotate the cable management arm **3**.
 - c. Flip the mounting brackets **4**.
 - d. Insert the inner bracket (marked with a capital letter I) and outer bracket (marked with a capital letter O) into the cable management arm **5**.

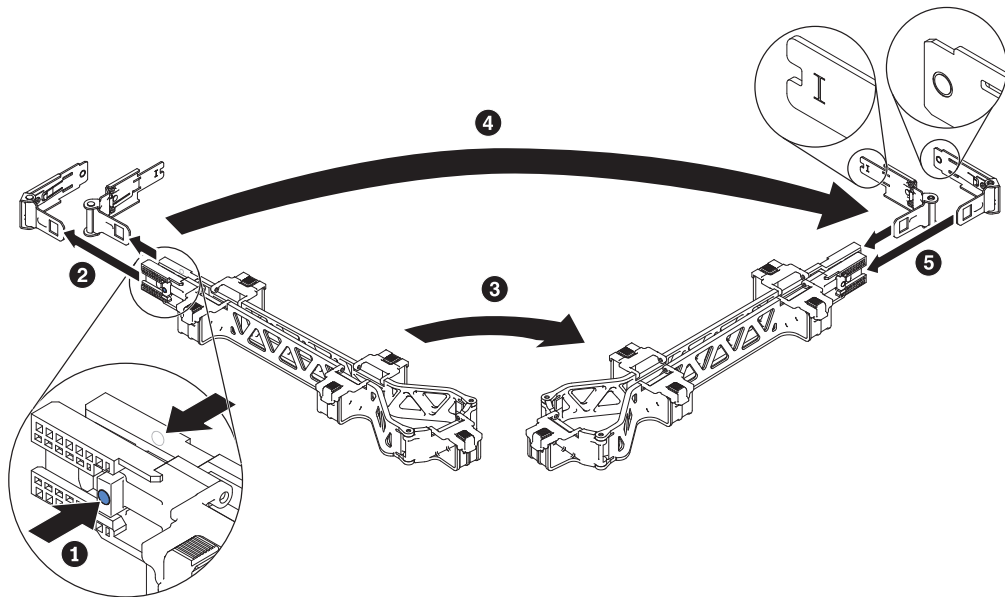

Figure 40. Installing the cable management arm on the opposite side

11. Insert the M6 screws to the rear of the slides, as shown in Figure 41. Use a cable tie to secure the free end of the cable management arm to the rack, if needed. See Figure 41.

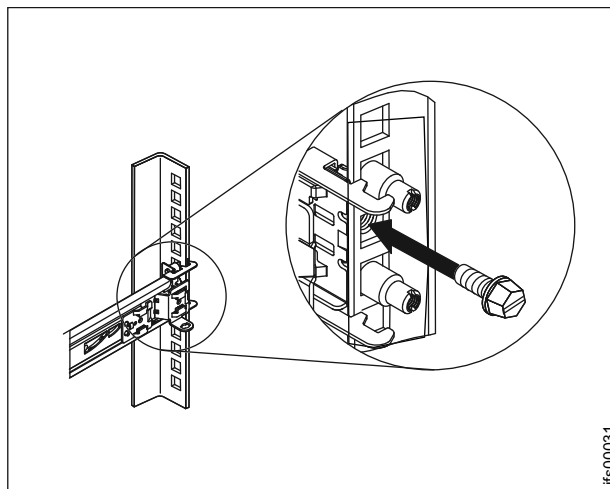

Figure 41. Securing the cable management arm and the file module in the rack for shipping if needed.

12. Slide the file module into the rack until it snaps into place. To slide the file module out of the rack, press on the release latches **1**.

Note: When you move the rack cabinet, or if you install the rack cabinet in a vibration-prone area, insert the M6 screws **2** in the front of the file module. Refer to Figure 42 on page 51.

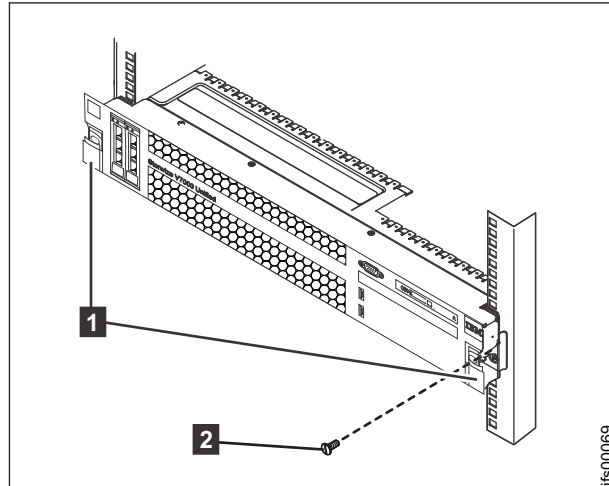

Figure 42. Installing the front screws

Step 10. Connecting the SAS cables to the expansion enclosures

Connect the SAS cables to the expansion enclosures.

About this task

This task applies if you are installing one or more expansion enclosures.

Note: The enclosure terminology that is used in this topic is described fully in Step 2. Identifying the hardware components.

Connecting SAS cables to Storwize V7000 Gen2 expansion enclosures

If you have installed expansion enclosures, you must connect them to a control enclosure.

About this task

This task applies if you are installing one or more expansion enclosures.

Note: When connecting SAS cables between enclosures, you must follow a list of guidelines to ensure that your configuration is valid. Do not begin connecting the cables until you have read SAS cabling guidelines.

Procedure

To install the cables, complete the following steps.

1. Using the supplied SAS cables, connect the control enclosure to the expansion enclosure at rack position 1, as shown in .
 - a. Connect SAS port 1 of the left node canister in the control enclosure to SAS port 1 of the left expansion canister in the first expansion enclosure.
 - b. Connect SAS port 1 of the right node canister in the control enclosure to SAS port 1 of the right expansion canister in the first expansion enclosure.

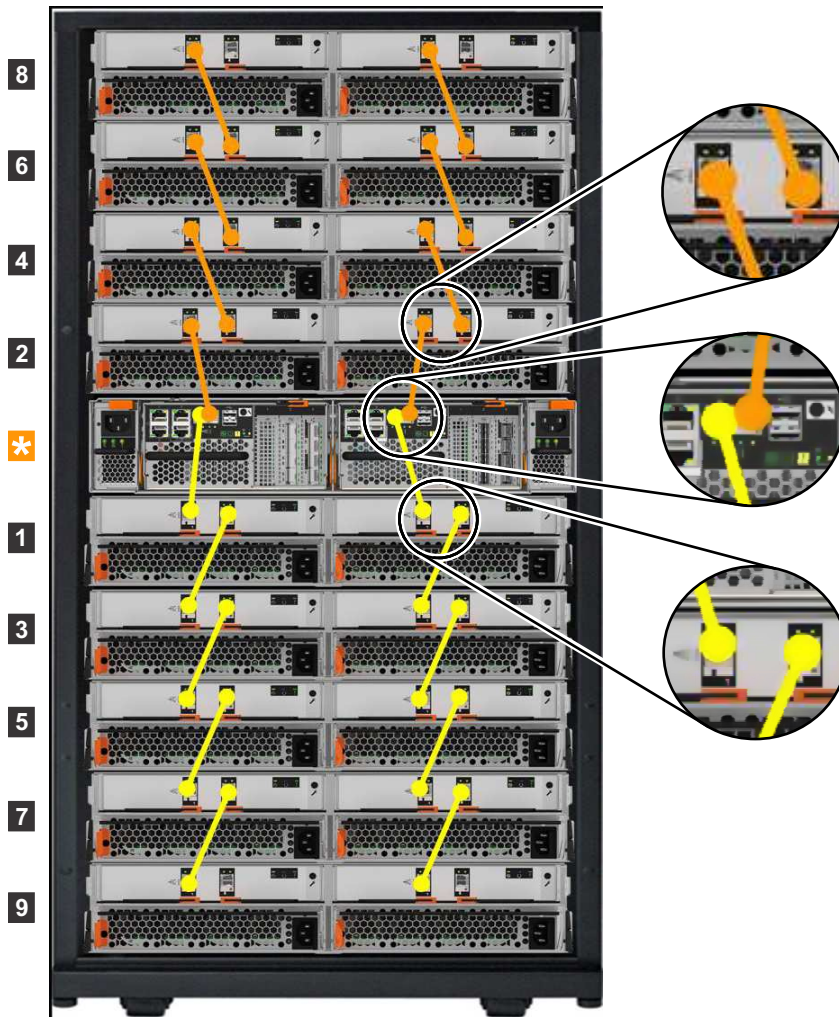

fab10007

Figure 43. Connecting the SAS cables

2. To add a second expansion enclosure chain to the control enclosure, use the supplied SAS cables to connect the control enclosure to the expansion enclosure at rack position 2. Refer to Figure 43 for an example.
 - a. Connect SAS port 2 of the left node canister in the control enclosure to SAS port 1 of the left expansion canister in the second expansion enclosure.
 - b. Connect SAS port 2 of the right node canister in the control enclosure to SAS port 1 of the right expansion canister in the second expansion enclosure.
3. If additional expansion enclosures are installed, connect each one to the previous expansion enclosure in a chain; use two Mini SAS HD to Mini SAS HD cables, as shown in Figure 43.

Note: A control enclosure can support up to 20 expansion enclosures (10 above the control enclosure and 10 below the control enclosure).

4. If additional control enclosures are installed, repeat this cabling procedure on each control enclosure and its expansion enclosures.

Step 10. Connecting SAS cables to the Storwize V7000 Gen1 expansion enclosures

Connect SAS cables to the Storwize V7000 Gen1 expansion enclosures.

About this task

This task applies if you are installing one or more expansion enclosures.

Note: Enclosure terminology is described in Step 2. Identifying the Storwize V7000 Gen1 hardware components.

Be aware of the following guidelines when you attach the cables to the SAS ports. Figure 44 on page 54 shows the internal cabling connections between the control enclosure (A) and the expansion enclosures (B & C).

- No more than five expansion enclosures can be chained to port 1 (below the control enclosure). The connecting sequence from port 1 of the node canister is called chain 1.
- No more than four expansion enclosures can be chained to port 2 (above the control enclosure). The connecting sequence from port 2 of the node canister is called chain 2.
- Do not directly connect ports on canisters above the control enclosure with ports on those canisters below the control enclosure.
- Attach cables serially between enclosures; do not skip an enclosure.
- The last enclosure in a chain must not have cables in port 2 of canister 1 and port 2 of canister 2.
- Ensure that cables are installed in an orderly way to reduce the risk of cable damage when replaceable units are removed or inserted.
- Arrange your cables to provide access to the following components:
 - USB ports. USB port access is required when you use a USB flash drive to configure the system.
 - The enclosures themselves. Access is required to the hardware for servicing and for safely removing and replacing components by two or more people.
- Ensure that each SAS cable is fully inserted. A click is heard when the cable is successfully inserted.

Note: If you make a mistake during cabling and must unplug a SAS cable, pull the blue tag to release the cable.

The following table refers to Figure 44 on page 54.

Table 14. Use this table to identify the file module, control enclosure, and expansion unit port locations. Follow the links to identify detailed port locations.

Key	Description	
A	Control enclosure. This unit consists of two canisters; the upper and the lower. The lower canister is position upside down.	1 SAS port 1 2 SAS port 2 3 SAS port 1 4 SAS port 2

Table 14. Use this table to identify the file module, control enclosure, and expansion unit port locations. Follow the links to identify detailed port locations. (continued)

Key	Description	
B	Expansion enclosure. This configuration is for enclosure units 1, 3, 5. This unit consists of two canisters; the upper and the lower. The lower canister is position upside down.	Note: All port locations are identical for B through C 5 SAS port 1 6 SAS port 2 The lower unit is upside down: 7 SAS port 2 8 SAS port 1
C	Expansion enclosure. This configuration is for enclosure units 2, 4, 6. This unit consists of two canisters; the upper and the lower. The lower canister is position upside down.	Ports are identical to B .

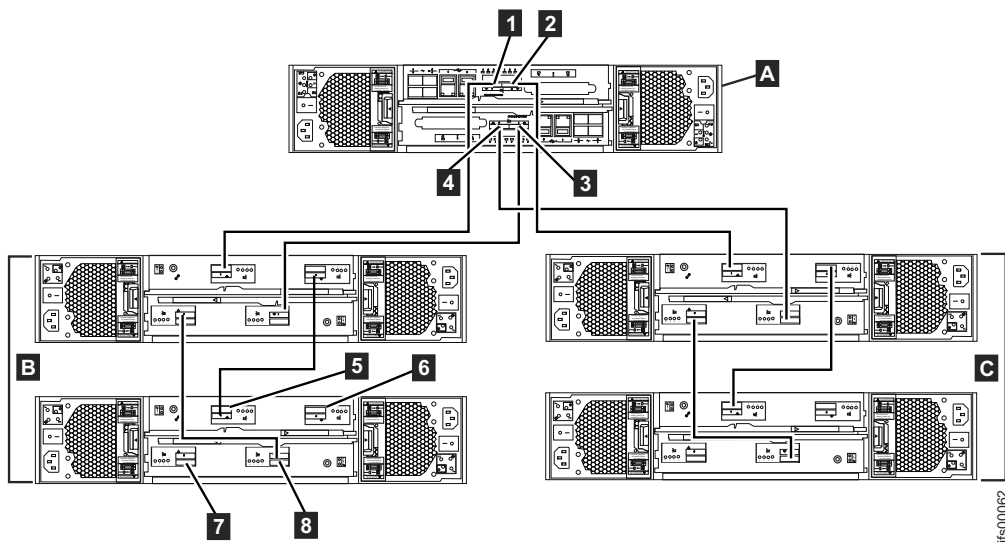

Figure 44. Internal cabling connections between the control enclosure (A) and the expansion enclosures (B & C)

Procedure

1. Review How to connect SAS cables to expansion units and the figures before you attach the SAS cables. The following table refers to Figure 44.

Table 15. How to connect SAS cables to expansion units.

SAS Connections: How the first unit connects to the second unit		
First Unit	Second Unit	Number of Expansions
Controller	Expansion 1	1 Expansions
Upper canister port 1	Upper canister port 1	
Lower canister port 1	Lower canister port 1	
Controller	Expansion 2	2 Expansions
Upper canister port 2	Upper canister port 1	
Lower canister port 2	Lower canister port 1	
Expansion 1	Expansion 3	3 Expansions
Upper canister port 2	Upper canister port 1	

Table 15. How to connect SAS cables to expansion units. (continued)

SAS Connections: How the first unit connects to the second unit		
First Unit	Second Unit	Number of Expansions
Lower canister port 2	Lower canister port 1	
Expansion 2	Expansion 4	4 Expansions
Upper canister port 2	Upper canister port 1	
Lower canister port 2	Lower canister port 1	
Expansion 3	Expansion 5	5 Expansions
Upper canister port 2	Upper canister port 1	
Lower canister port 2	Lower canister port 1	
Expansion 4	Expansion 6	6 Expansions
Upper canister port 2	Upper canister port 1	
Lower canister port 2	Lower canister port 1	
Expansion 5	Expansion 7	7 Expansions
Upper canister port 2	Upper canister port 1	
Lower canister port 2	Lower canister port 1	
Expansion 6	Expansion 8	8 Expansions
Upper canister port 2	Upper canister port 1	
Lower canister port 2	Lower canister port 1	
Expansion 7	Expansion 9	9 Expansions
Upper canister port 2	Upper canister port 1	
Lower canister port 2	Lower canister port 1	

2. Attach the SAS cables from the control enclosure to the first expansion enclosure as shown in Figure 45. Remove the protective end covers, if necessary. The first expansion enclosure is below the control enclosure.

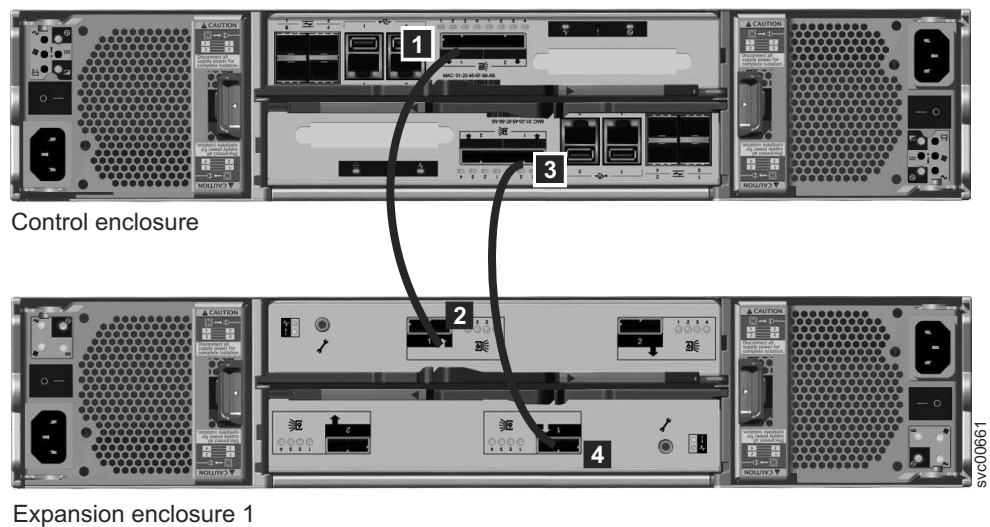

Figure 45. Attaching an expansion enclosure to the control enclosure

- a. Port 1 **1** of the upper canister, control enclosure, attaches to Port 1 **2** of the upper canister, expansion enclosure 1.

- b. Port 1 **3** of the lower canister, control enclosure, attaches to Port 1 **4** of the lower canister, expansion enclosure 1. The port locations on the lower canister are inverted from the port locations on the upper canister. Port 1 on the lower canister is opposite port 1 on the upper canister.

Note: The connecting sequence from port 1 of the node canister is called chain 1.

3. Attach the SAS cables from the control enclosure to the second expansion enclosure as shown in Figure 46. The second expansion enclosure is above the control enclosure.

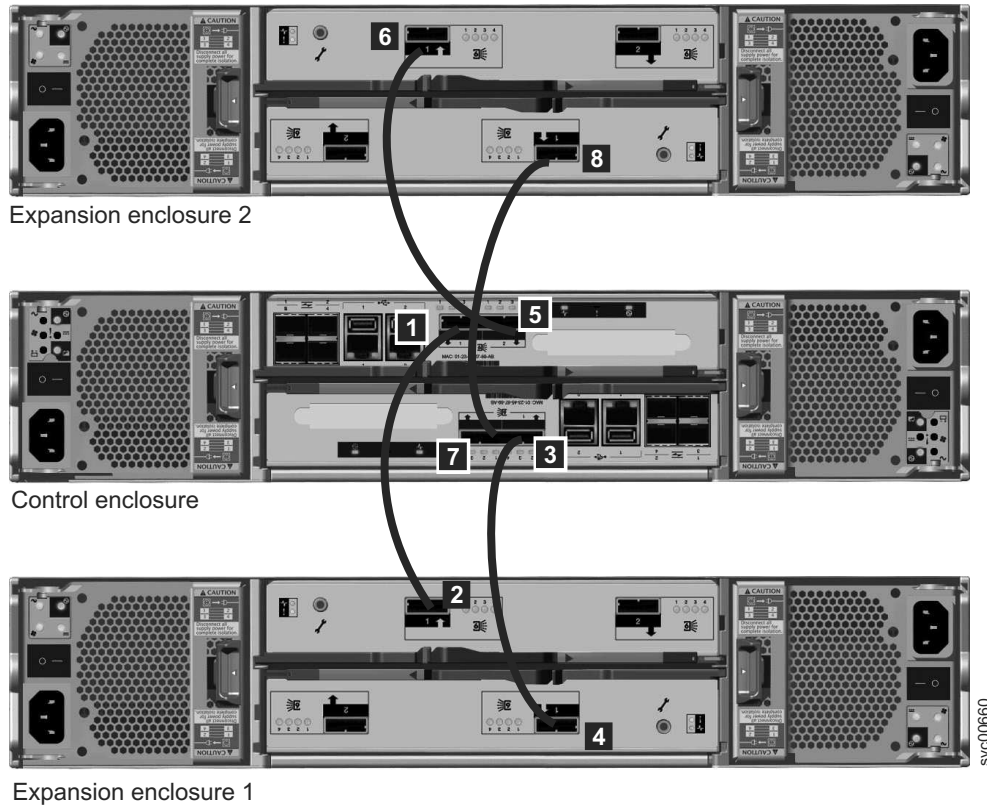

Figure 46. Adding a second expansion enclosure

- a. Port 2 **5** of the upper canister, control enclosure, attaches to Port 1 **6** of the upper canister, expansion enclosure 2.
- b. Port 2 **7** of the lower canister, control enclosure, attaches to Port 1 **8** of the lower canister, expansion enclosure 2. The port locations on the lower canister are inverted from the port locations on the upper canister. Port 1 on the lower canister is opposite port 1 on the upper canister.

Note: The connecting sequence from port 2 of the node canister is called chain 2.

4. Attach the SAS cables from the first expansion enclosure to the third expansion enclosure. See Figure 47 on page 57.

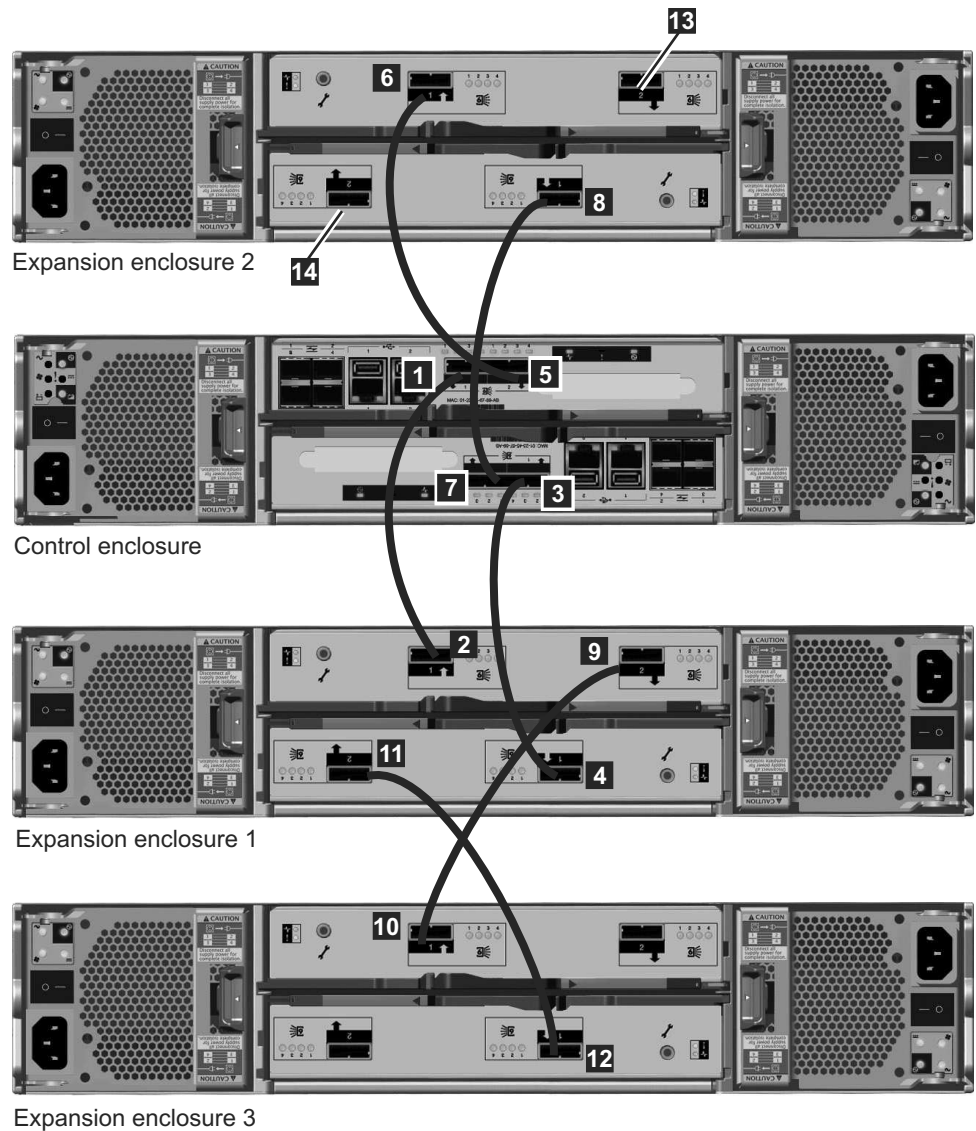

Figure 47. Attaching SAS cables to the enclosures

- a. Port 2 **9** of the upper canister, expansion enclosure 1, attaches to Port 1 **10** of the upper canister, expansion enclosure 3.
- b. Port 2 **11** of the lower canister, expansion enclosure 1, attaches to Port 1 **12** of the lower canister, expansion enclosure 3.
5. Attach SAS cables for more expansion enclosures. You can add up to nine expansion enclosures. You add a fourth expansion enclosure at **13** and **14** on expansion enclosure 2.
 - a. Add the enclosures alternately to chain 1, and then chain 2.
 - b. Use port 2 on the canisters that are already connected to attach to port 1 on the canisters of the enclosures that you want to add.
6. Verify your cabling.

Step 11. Attaching the Ethernet cables

Attach the Ethernet cables to the control enclosures and file modules.

About this task

This task guides you through connecting both the internal and external Ethernet connections for your system.

This task assumes that your initial planning has determined where the Ethernet cables are to be located. The Storwize V7000 Unified control enclosure requires at least one and a maximum of two 1 Gbps Ethernet connections to each node canister. Refer to Figure 48, Figure 49 on page 59, and Figure 50 on page 59; also Table 16 on page 60 and Table 17 on page 61. For the file modules, the first two 1 Gbps Ethernet ports that are labeled **1** and **2** in Figure 52 on page 62 are used for internal communications between the file modules.

Note: It is important that the file modules are able to communicate over the network with the Storwize V7000 control enclosure for management and service.

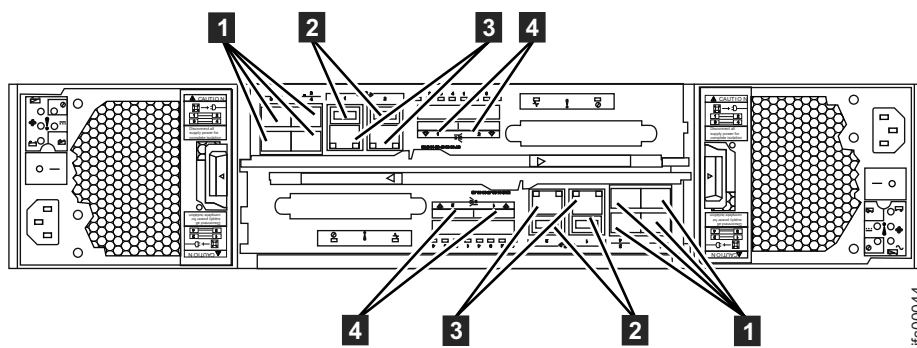

Figure 48. Control enclosure Ethernet network connections.

- **1** Fibre Channel ports (8 Gbps). Each node canister has four Fibre Channel ports. They are in a block of four in two rows of two connectors. The ports are numbered 1 - 4 from left to right, top to bottom. Two ports connect to the file modules and two are connected to the SAN.
- **2** USB ports. Each node canister has two USB ports. The ports are side by side on the canister and are numbered 1 on the left and 2 on the right. One port is used during installation.
- **3** Ethernet ports (1 Gbps). Each canister has two Ethernet ports. The ports are side by side on the canister. They are numbered 1 on the left and 2 on the right on the upper canister. The port locations are inverted for the lower canister. Port 1 must be connected first; the use of port 2 is optional.
- **4** Serial-attached SCSI (SAS) ports (6 Gbps). Each node canister has two SAS ports. The ports are side by side on the canister. They are numbered 1 on the left and 2 on the right. Port 1 must be connected first if you are adding one expansion enclosure. Port 2 must be connected if you are adding a second expansion enclosure.

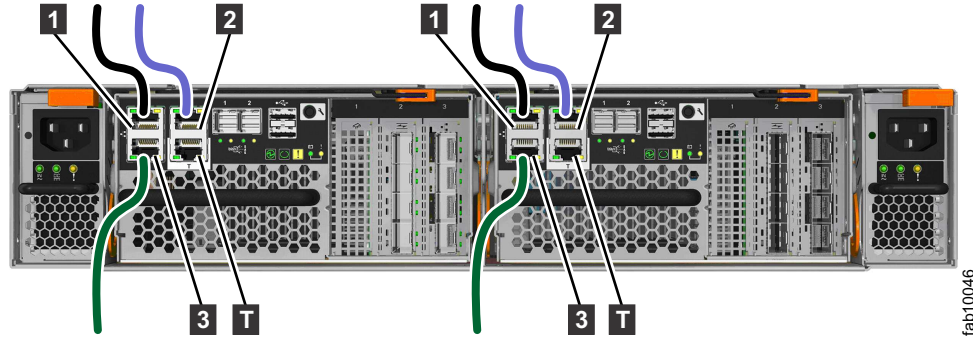

Figure 49. Storwize V7000 Gen2 control enclosure Ethernet network connections

The Ethernet ports are numbered next to each port on the Storwize V7000 Gen2 node canisters.

Ethernet port **1** (upper left; black cable in Figure 49)

Ethernet port **2** (upper right; blue cable in Figure 49)

Ethernet port **3** (lower left; green cable in Figure 49)

The technician port **T** (lower right) is used for troubleshooting or servicing the system

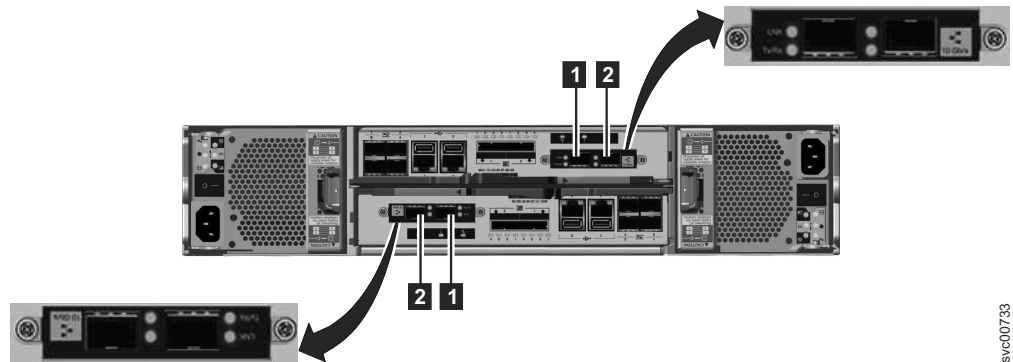

Figure 50. 10 Gbps Ethernet ports on the rear of the Storwize V7000 enclosure

- **1** 10 Gbps Ethernet port 3, which is the left port.
- **2** 10 Gbps Ethernet port 4, which is the right port.

Table 16. Ethernet connections available with the control enclosure

Item	Port	Purpose	IP address is assigned by InitTool	Use
3 (left port, Figure 48 on page 58)	Built-in Ethernet port 1	1 Gbps external network connection	Yes	Management and service port for each canister, optional iSCSI. (The Storwize V7000 control enclosure must be able to communicate over the network with the file modules.)
3 (right port Figure 48 on page 58)	Built-in Ethernet port 2	1 Gbps external network connection	No	Optional management and service port, optional iSCSI
1 (Figure 50 on page 59)	Ethernet port 3 on a 2076-312 or 2076-324	10 GbE external network connection	No	Optional iSCSI
2 (Figure 50 on page 59)	Ethernet port 4 on a 2076-312 or 2076-324	10 GbE external network connection	No	Optional iSCSI

If optional 4-port 10 Gbps Ethernet interface adapters are installed in the node canisters, connect each port to the network that will provide connectivity to that port. Connect both node canisters in a control enclosure to the same networks to provide redundant connectivity.

Figure 51 shows the additional Ethernet ports when an optional 10 Gbps Ethernet interface adapter is present in PCI slot 3.

T is the technician port. Never connect a technician port to a network switch.

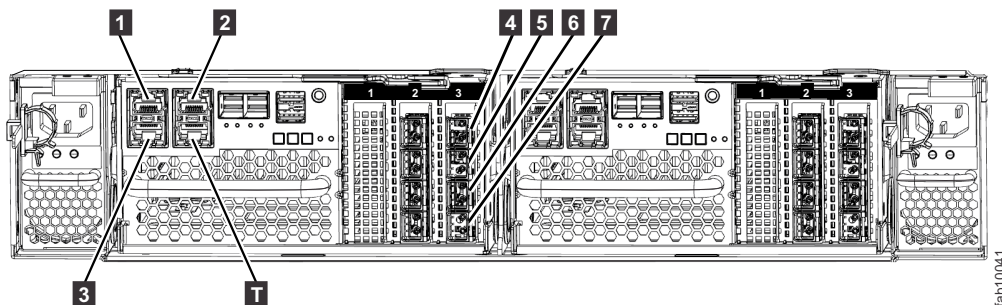

Figure 51. Ethernet ports when an optional 10 Gbps Ethernet interface adapter is present in PCI slot 3

Table 17. Ethernet connections available with the Storwize V7000 Gen2 control enclosure

Item	Port	Purpose	IP address is assigned by InitTool	Use
1 (Figure 51 on page 60)	Built-in Ethernet port 1	1 Gbps external network connection	Yes	Management and service port for each canister; optional iSCSI. (The Storwize V7000 control enclosure must be able to communicate over the network with the file modules.)
2 (Figure 51 on page 60)	Built-in Ethernet port 2	1 Gbps external network connection	No	Optional management and service port; optional iSCSI
3 (Figure 51 on page 60)	Built-in Ethernet port 3	1 Gbps external network connection	No	Optional management and service port; optional iSCSI
4 (Figure 51 on page 60)	Ethernet port 4	10 GbE external network connection	No	Optional iSCSI
5 (Figure 51 on page 60)	Ethernet port 5	10 GbE external network connection	No	Optional iSCSI
6 (Figure 51 on page 60)	Ethernet port 6	10 GbE external network connection	No	Optional iSCSI
7 (Figure 51 on page 60)	Ethernet port 7	10 GbE external network connection	No	Optional iSCSI

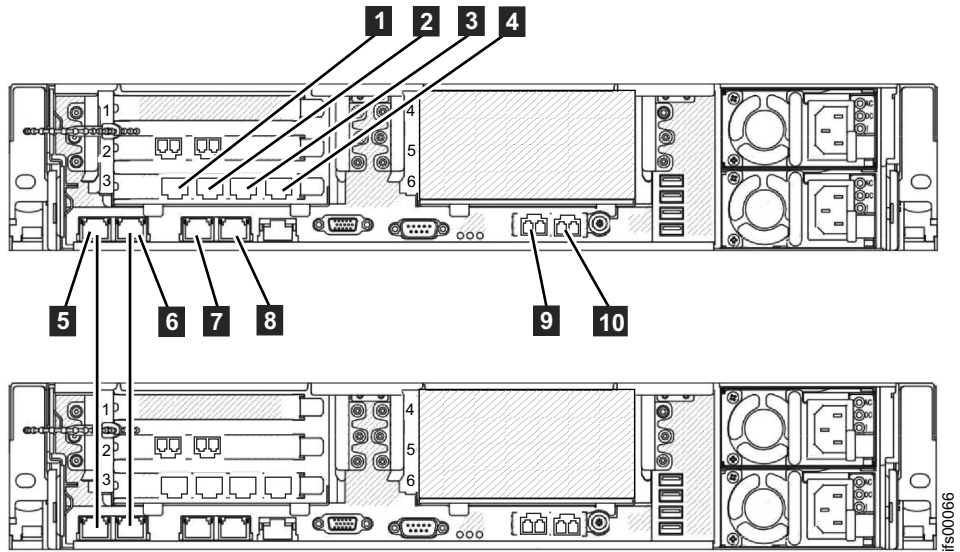

Figure 52. File module Ethernet connections.

Table 18. Ethernet connections available with the file modules

Item	Port	IP address is assigned by InitTool	Use
1	Ethernet port 7		Connect to a switch for public file access
2	Ethernet port 8		Connect to a switch for public file access
3	Ethernet port 9		Connect to a switch for public file access
4	Ethernet port 10		Connect to a switch for public file access
5	Ethernet port 1	From the internal IP address range	Connect to the other file module
6	Ethernet port 2	From the internal IP address range	Connect to the other file module
7	Ethernet port 3	File module service and system management IP address	Connect to a switch for public file access and system management
8	Ethernet port 4		Connect to a switch for public file access
9	Ethernet port 5 (10 Gbps optical)		Connect to a switch for public file access and optional system management
10	Ethernet port 6 (10 Gbps optical)		Connect to a switch for public file access

Attention: The default service IP addresses on your new Storwize V7000 Unified control enclosure might conflict with existing devices that are attached to the network or with other new control enclosures that you are installing. The service IP address 192.168.70.121 subnet mask 255.255.255.0 is preconfigured on Ethernet port 1 of the upper canister, canister 1. The service IP address 192.168.70.122 subnet mask 255.255.255.0 is preconfigured on Ethernet port 2 of the lower canister, canister 2.

If you encounter that situation, change the service IP addresses on the new nodes before connecting the Ethernet cables. For details, see Figure 52 on page 62 or see the *Storwize V7000 Unified Problem Determination Guide* PDF on the DVD for further information about setting service IP addresses using a USB flash drive.

File module to file module:

- Connect an Ethernet cable from Ethernet port 1 on the first file module to the first Ethernet port 1 the second file module. Refer to Figure 52 on page 62 for port locations.

Note: Ethernet cables for the internal network are provided by IBM with the file modules.

- Connect an Ethernet cable from Ethernet port 2 on first file module to Ethernet port 2 on the second file module.
- Route the Ethernet cables through the cable management arms, and secure any excess using the cable retention features of the rack.

File module management and public ports:

- Connect an Ethernet cable from Ethernet port 3 on the first file module to an Ethernet network. If using two Ethernet cables (as recommended), connect another Ethernet network cable to Ethernet port 4. When using only one Ethernet port, the network status is marked as degraded and an associated warning event is listed in the health center.
- Optionally, connect as many other file module Ethernet ports to network switches as you require
- Repeat the previous step for the second file module.
- Route the Ethernet cables through the cable management arm, and secure any excess using the cable retention features of the rack.

File modules to external (host ports) network (10 GB Fibre Ethernet):

You have two 10 Gbps Fibre Ethernet ports available for host connections from each file module. Connect your network cables to the Ethernet ports in these slots as applicable. Refer to Figure 52 on page 62.

Step 12. Attaching the Fibre Channel cables

Attach the Fibre Channel cables from the file modules to the control enclosure.

About this task

To attach the Fibre Channel cables, follow these steps:

1. Connect two Fibre Channel cables from the first file module to the control enclosure. Be sure to plug one cable into one node canister on the control enclosure and the other cable into the other node canister for redundancy. Route the Fibre Channel cables through the cable management arms.

Note: Fibre Channel cables are provided by IBM with the file modules.

2. Repeat step 1 on page 63 for the other file module.
3. Before you continue, make sure that you have connected the Fibre Channel cabling as shown in Figure 53 (Storwize V7000 Gen1) or Figure 54 on page 65 (Storwize V7000 Gen2) to ensure proper redundancy. Incorrect cabling might result in a loss of service during system maintenance procedures.
4. Secure any excess cable length by using the cable retention features of the rack.

Note: After the blue indicator light appears when the file modules are powered on, the amber LED (with the number 8 stamped on the metal next to each Fibre Channel port) should be lit to show that the link speed is 8 Gbps.

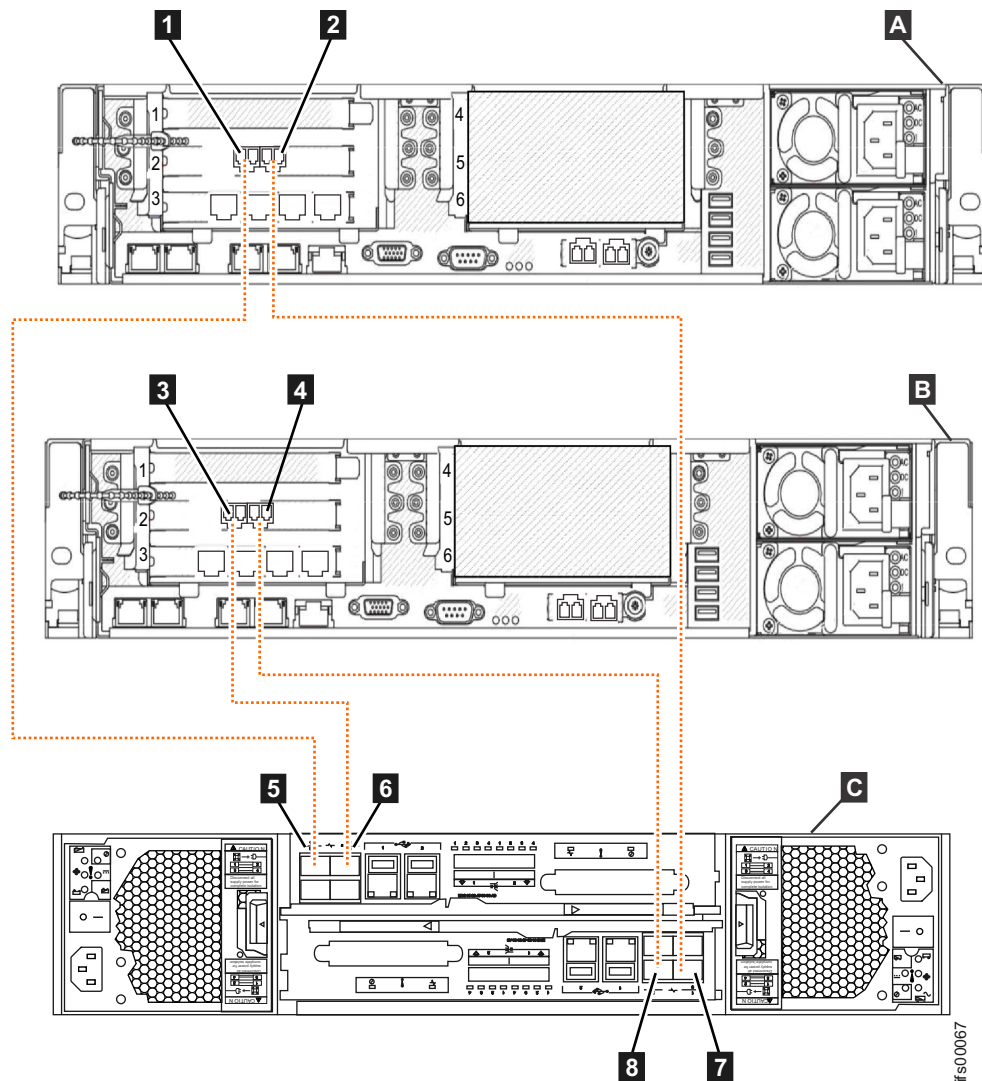

Figure 53. Connecting the file modules to the Storwize V7000 Gen1 control enclosure using Fibre Channel cables

- **A** File module 1
- **B** File module 2
- **C** Storwize V7000 control enclosure
- **1** File module 1 - Fibre Channel port 1
- **2** File module 1 - Fibre Channel port 2

- **3** File module 2 - Fibre Channel port 1
- **4** File module 2 - Fibre Channel port 2
- **5** Upper node canister - Fibre Channel port 1
- **6** Upper node canister - Fibre Channel port 2
- **7** Lower node canister - Fibre Channel port 1
- **8** Lower node canister - Fibre Channel port 2

Note: If you want this control enclosure to communicate with other Storwize V7000 control enclosures, storage controllers, the Storwize V7000 Unified or block hosts, then connect the Fibre cables from your Fibre Channel switch to the remaining node canisters Fibre Channel ports 3 and 4.

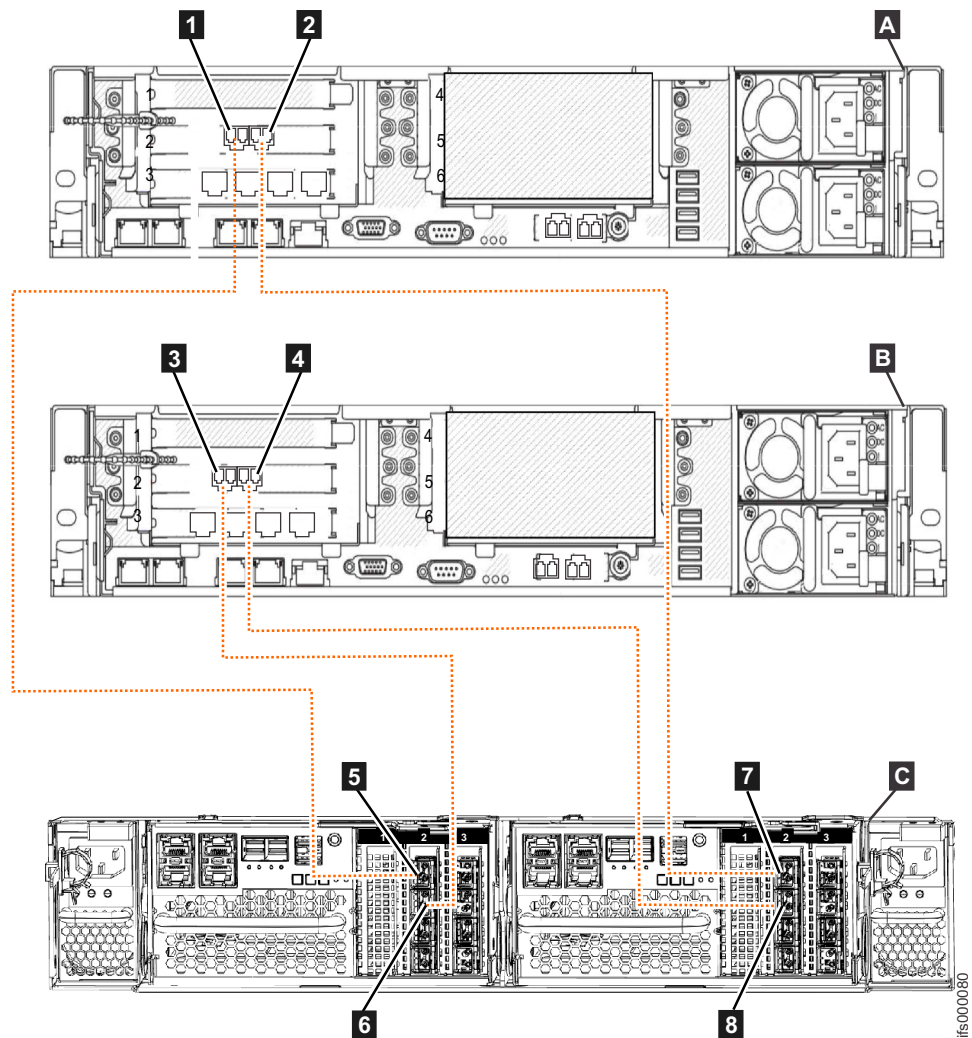

Figure 54. Connecting the file modules to a Storwize V7000 Gen2 control enclosure that has a Fibre Channel interface adapter in PCI slot 2 of each node canister

- **A** File module 1
- **B** File module 2
- **C** Storwize V7000 Gen2 control enclosure (2076-524)
- **1** File module 1 - Fibre Channel port 1
- **2** File module 1 - Fibre Channel port 2

- **3** File module 2 - Fibre Channel port 1
- **4** File module 2 - Fibre Channel port 2
- **5** Node canister 1 (left) - Fibre Channel port 1
- **6** Node canister 1 (left) - Fibre Channel port 2
- **7** Node canister 2 (right) - Fibre Channel port 1
- **8** Node canister 2 (right) - Fibre Channel port 2

Note: If you want this control enclosure to communicate with other Storwize V7000 control enclosures, storage controllers, Storwize V7000 Unified or block hosts, then connect the Fibre cables from your Fibre Channel switch to the remaining node canisters Fibre Channel ports 3 and 4 (or 3 - 8 if the second Fibre Channel interface adapter is fitted in PCI slot 3).

Step 13. Connecting the power cords

Connect the power cords to the power supply units.

About this task

Control enclosure:

Two power supply units are located in each enclosure. Ensure that the power switches for the control enclosure and expansion enclosures power supply unit are switched off.

Note: Each power supply unit comes with an attached cable retention bracket that fastens around the power cord to prevent the cord from being removed accidentally.

Do the following steps when you attach the power cord to each power supply unit:

1. Straighten the cable tie on the cable retention bracket. The cable retention bracket is attached to the power supply unit.
2. Open the cable retention bracket, as shown in Figure 55 on page 67.



Figure 55. Unlocking the cable retention bracket

3. Slide the cable retention bracket away from the power supply unit until there is enough room to attach the cable retention bracket to the cable. When sliding the bracket away from the cable plug-in, pull the lever on the bracket that controls the cable tie slightly towards the center of the canister. You do not need to pull the lever to slide the bracket towards the cable plug-in.
4. Attach a power cord to each of the two power supply units in each enclosure. Ensure that cables are installed in an orderly way to reduce the risk of cable damage when replaceable units are removed or inserted.
5. Place the cable retention bracket around the end of the cable that plugs into the power supply unit.
6. Slide the cable retention bracket along the cord until it fits snugly against the plug end of the cable, as shown in Figure 56 on page 68.

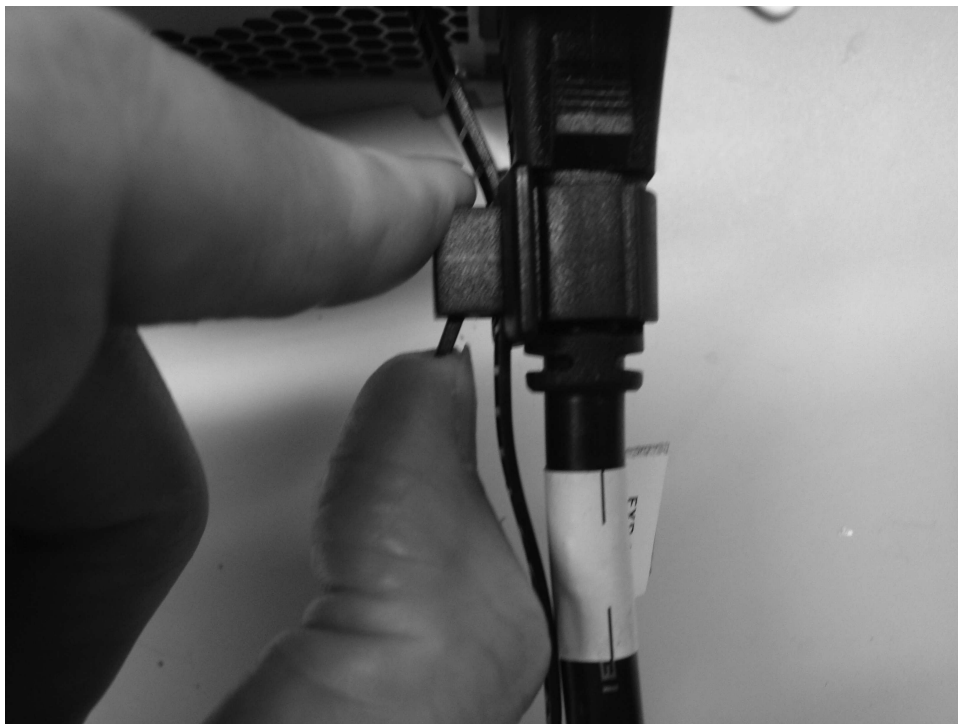

Figure 56. Sliding the cable retention bracket directly behind the power cord

7. Tighten the fastener around the plug.
8. Repeat the steps for each additional power cord.
9. Plug the power cords into a properly grounded electrical outlet. To provide power failure redundancy, plug the power cords for the individual power supply units for each enclosure into separate power distribution units, if possible.

File modules:

Do the following steps when you attach the power cord to each power supply unit:

1. Connect two power cords from a file module rack power supply. Plugging them into separate Power Distribution Units (PDUs) is recommended for redundancy. Route the power cords through the Cable Management Arms.
2. Repeat the previous step for the other file module.
3. Secure any excess cable length using the cable retention features of the rack.

Step 14. Powering the system on and off

Power on the system after the cables and power cords are properly installed.

About this task

Follow the procedures for powering on the expansion enclosure and file modules, and in the order specified.

Powering on the Storwize V7000 Gen2 system

After you install all hardware components, you must power on the system and check its status.

About this task

Attention: Do not power on the system with any open bays or slots.

- Every unused drive bay must be occupied by a filler panel.
- Filler panels must be installed in all empty host interface adapter slots.

Open bays or slots disrupt the internal air flow, causing the drives to receive insufficient cooling.

Procedure

To power on the system, complete the following steps.

1. Power on the control enclosure. Use the supplied power cords to connect both power supply units of the enclosure to their power sources. If the power sources have circuit breakers or switches, ensure that they are turned on. The enclosure does not have power switches.

Note: Each enclosure has two power supply units. To provide power failure redundancy, connect the two power cords to separate power circuits.

2. From the rear of the control enclosure, check the LEDs on each node canister (see Figure 57).

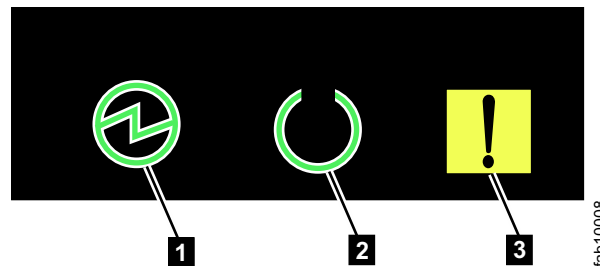

Figure 57. Node canister LEDs

- 1** Power
- 2** Status
- 3** Fault

The canister is ready with no critical errors when **Power** is illuminated, **Status** is flashing, and **Fault** is off. If a canister is *not* ready, refer to the “Procedure: Understanding the system status using the LEDs” topic in “Troubleshooting”.

Step 14. Powering the Storwize V7000 Gen1 system on and off

About this task

Follow the procedures for powering on the expansion enclosure and file modules, and in the order specified.

Attention: Do not operate the system when the drive assemblies are missing. Drive assemblies that are missing disrupt the airflow; the drives do not receive sufficient cooling. You must insert blank carriers into unused drive bays.

Powering on an expansion enclosure:

1. Power on the newly installed enclosures. Use the power switch on each of the two power supply units in the back of the expansion enclosure.
2. Use the information in Table 20 on page 71 to verify the state of the light emitting diodes (LEDs) on the system. Verify that no faults are detected. See the *Storwize V7000 Unified Problem Determination Guide* PDF on the CD if problems are encountered.

Both Figure 58 and Figure 59 show the location of the LEDs on the power supply units, located at the front of the expansion enclosure. Figure 60 on page 71 shows the location of the LEDs on the power supply units, located at the rear of the expansion enclosure. The LEDs are located at position **1**.



Figure 58. 24 drives and two end caps

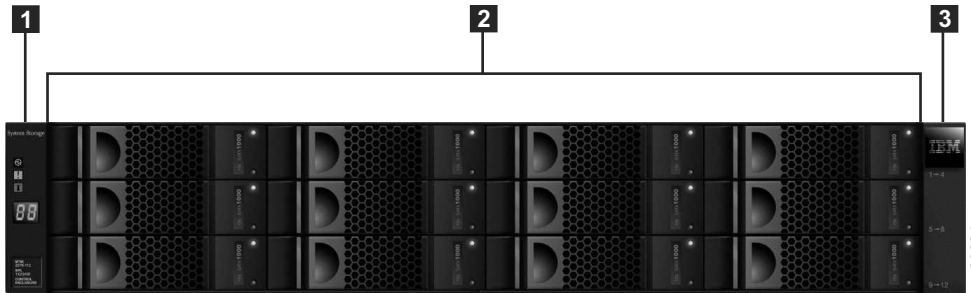



Figure 59. Storwize V7000 Gen1 12 drives and two end caps

Table 19. LED status front of control enclosure or expansion enclosure. Refers to item [1] in the figures above.

Hardware component	LED name and symbol	If power on and no fault is detected
Left enclosure end cap, front of enclosure	Power, top 	LED is on.
	Fault, middle !	LED is off.
	Identify, bottom 	LED is off.

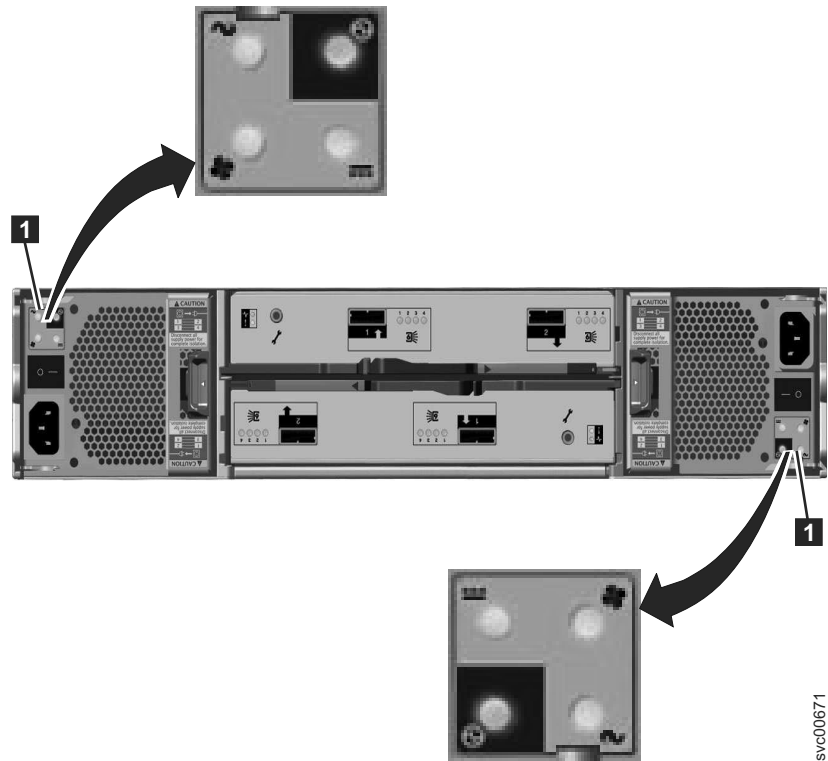







Figure 60. LEDs on the power supply units of the expansion enclosure

Table 20. LED status rear of expansion enclosure.

Hardware component	LED name and symbol	If power on and no fault is detected
Expansion canister, rear. The reference to the top and bottom locations applies to canister 1, which is the upper canister. The LED locations are inverted for canister 2, which is the lower canister.	Canister status, top 	LED is on.
	Fault status, bottom 	LED is off.
	SAS ports	When a SAS port is functioning correctly, all four green LEDs above the port are on. If no cable is plugged into the port, or if the canister at either end of the cable is not yet fully started, the LEDs are not on.
Power supply unit, expansion enclosure. The reference to the left and right locations applies to power supply unit 1, which is the left power supply. The LED locations are inverted for power supply unit 2, which is the right power supply.	Power supply, upper right 	LED is on.
	Fan failure 	LED is off.
	DC power failure 	LED is off.
	AC power failure 	LED is off.

Powering on a control enclosure:

1. Power on the control enclosure, if it is not already powered on and configured. Use the power switch on each of the two power supply units, located in the back of the enclosure.
2. Use Table 21 to verify the state of the LEDs on the system. Verify that no faults are detected.

Figure 61 shows the location of the LEDs on the power supply units in the rear of the control enclosure.

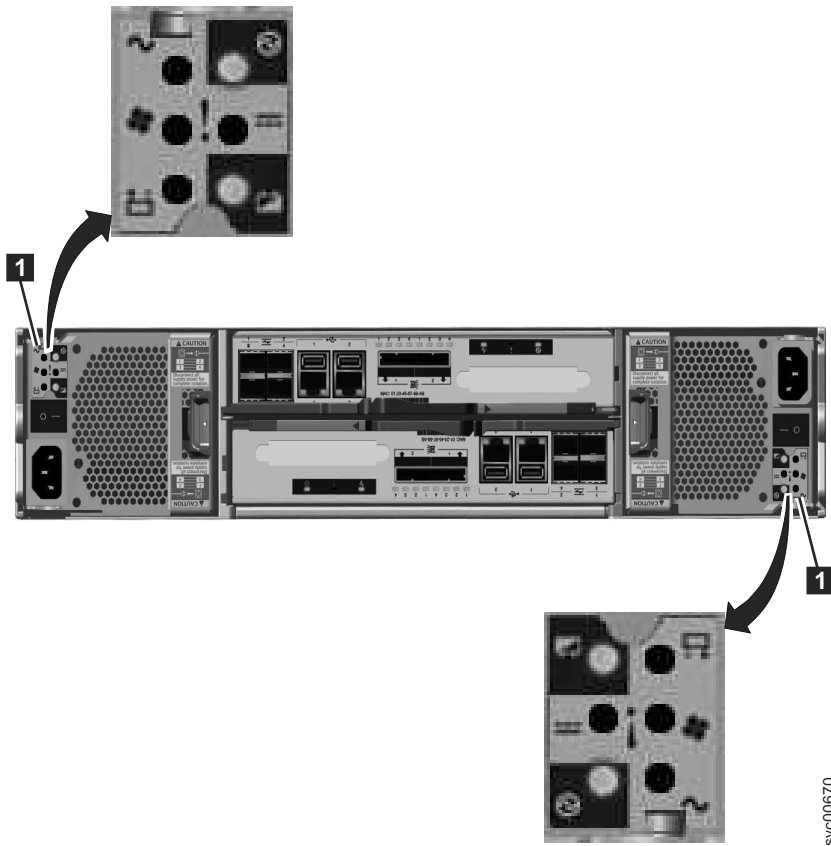

Figure 61. LEDs on the power supply units of the control enclosure

Table 21. LED status when control enclosure is powered on













Hardware component	LED name	If power on and no fault is detected
Left enclosure end cap, front of enclosure	Power, top 	LED is on.
	Fault, middle 	LED is off.
	Identify, bottom 	LED is off.

Table 21. LED status when control enclosure is powered on (continued)

Hardware component	LED name	If power on and no fault is detected
Node canister, rear. The reference to the top and bottom locations applies to canister 1, which is the upper canister. The LED locations are inverted for canister 2, which is the lower canister.	Fibre Channel port	If the Fibre Channel port is used: One or more LEDs are on or flashing per port. The LEDs are located between the Fibre Channel ports. The arrow-shaped LEDs point toward the affected port.
	Ethernet port, if used	One or more LEDs are on per port.
	SAS ports	When a SAS port is functioning correctly, all four green LEDs above the port are on. If no cable is plugged into the port, or if the canister at either end of the cable is not yet fully started, the LEDs are not on.
	System status, left 	LED is flashing or on. The status is on if the node canister is an active member of a clustered system. The LED is flashing if the node canister is in service or candidate state. If the LED is off, the node canister might still be booting up. Wait up to 5 minutes for the node canister to complete booting up.
	Fault status, middle 	LED is off.
	Power status, right 	LED is on.
Power supply unit, control enclosure. The reference to the left and right locations applies to power supply unit 1, which is the left power supply. The LED locations are inverted for power supply unit 2, which is the right power supply.	Power supply, upper right 	LED is on.
	AC power failure 	LED is off.
	DC power failure 	LED is off.
	Fan failure 	LED is off.
	Battery failure 	LED is off
	Battery good, lower right 	LED is on or flashing.

Attention: Do not go to the next section until the LEDs are in the required states. If any error lights are displayed, see the *Storwize V7000 Unified Problem Determination Guide* documentation CD for more information about light path issues.

File module power features:

When the file module is connected to a power source but is not turned on, the operating system does not run, and all core logic except for the integrated management module is shut down. However, the file module can respond to requests from the integrated management module, such as a remote request to turn on the file module. The power-on LED flashes to indicate that the file module is connected to power but is not turned on. The power on LED is found in the front of the file module.

Powering on the file module

Approximately 3 minutes after the file module is connected to power, the power-control button becomes active. Also, one or more fans might start running to provide cooling while the file module is connected to power. You can turn on the file module and start the operating system by pressing and releasing the power on button. The power on button is located at the front of the file module.

Turning off the file module

When you turn off the file module and leave it connected to power, the file module can respond to requests from the integrated management module. For example, it can respond to a remote request to turn on the file module. While the file module remains connected to power, one or more fans might continue to run. To remove all power from the file module, you must disconnect it from the power source.

Important: To view the error LEDs on the system board, leave the file module connected to a power source.

Some operating systems require an orderly shutdown before you turn off the file module. See your operating-system documentation for information about shutting down the operating system.

CAUTION:

The power on button on the device does not turn off the electrical current supplied to the device. The device also might have more than one power cord. To remove all electrical current from the device, ensure that all power cords are disconnected from the power source.

Press and release the power on button to start an orderly shutdown of the operating system and turn off the file module, if your operating system supports this feature

Attention: If you have a problem powering off the system, see the *Storwize V7000 Unified Problem Determination Guide* documentation CD for more information about light path issues.

Powering the file modules on and off

When the file module is connected to a power source but is not turned on, the operating system does not run, and all core logic except for the integrated management module is shut down.

The power-on LED flashes to indicate that the file module is connected to power but is not turned on. The power-on LED is found in the front of the file module. See **1** in Figure 62 on page 75.

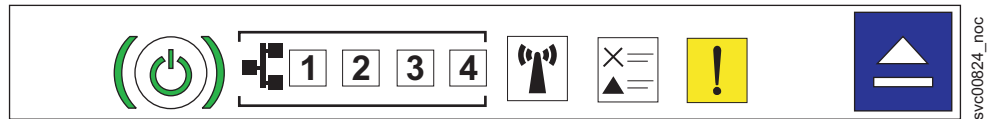

Figure 62. Power LED location on file module

1 - Power button and power LED (green)

Approximately 3 minutes after the file module is connected to power, the power-control button becomes active. Also, one or more fans might start running to provide cooling while the file module is connected to power. You can turn on the file module and start the operating system by pressing and releasing the power-on button. The power-on button is at the front of the file module.

While the file module remains connected to power, one or more fans might continue to run. To remove all power from the file module, you must disconnect it from the power source.

Important: To view the error LEDs on the system board, leave the file module connected to a power source.

CAUTION:

The power-control button on the device does not turn off the electrical current supplied to the device. The device might also have more than one connection to dc power. To remove all electrical current from the device, ensure that all connections to dc power are disconnected at the dc power input terminals. (C031)

Press and release the power-on button to start an orderly shutdown of the operating system and turn off the file module, if your operating system supports this feature.

If you can access the management GUI, it is best to use the management GUI to first power off the file module that is not the active management node, and then power off the active management node.

Attention: If you have a problem powering off the system, see the *Storwize V7000 Unified Problem Determination Guide*, available on the Information Center Web site, for more information about light path issues.

Chapter 3. Configuring the system

Set up your system for the first time.

About this task

Setting up your system for the first time:

Before you begin, make sure you have worked through **Before you begin the installation** and that your system is properly cabled for the Storwize V7000 Unified system and any expansion enclosures. Refer to the cabling sections listed under **Performing the hardware installation**. The following guides you through setting up your system for the first time. The process includes the following key steps:

- Initialize the Storwize V7000
- Initialize the file modules
- Configure the software
- Check the Storwize V7000 Unified system status
- Update the Storwize V7000 Unified software

Step 15. Using InitTool.exe on the USB flash drive

The USB flash drive is required to initialize the system.

About this task

Important: You must check carefully that the IP addresses that you provide to InitTool.exe are valid and not already in use by some other system on the network apart from the gateway IP address. If you provide an IP address that is already in use then the initial setup may appear to be successful and the system could work for some time before random problems start to happen which are very hard to troubleshoot.

Procedure

1. Locate the USB flash drive that was shipped with your order in the documentation package.

Note: You might encounter a problem where the code cannot be run if you use your own USB flash drive. The USB flash drive that you use must:

- Contain a FAT32 formatted file system on its first partition. NTFS and other file system types are not supported.
 - Contain a copy of the Microsoft Windows USB flash drive InitTool.exe executable that is located in the root directory of the file system.
 - Be write enabled.
2. Insert the USB flash drive into a USB port in a personal computer that is running Microsoft Windows 7 Professional or higher.

If the system is configured to autorun for USB keys, the initialization tool starts automatically. Otherwise, open the USB flash drive from **My Computer** and double-click the InitTool.exe.

Note: If you are running a non-Windows operating system, skip to 4.

3. Select the **Initialize a new Storwize V7000 Unified** option from the Welcome panel of the initialization tool. Click **Next**. Use the initialization tool to complete the following steps:

Note: See 4 for details on IP addresses that are used in these steps.

- a. Enter the primary IP address of the Storwize V7000 system, netmask for this network subnet, and gateway IP addresses for this network subnet. Click **Next**.
- b. Enter the **Management IP** address, **File Module 1**, and **File Module 2** IP addresses. Click **Next**.
- c. Read the instructions of what to do next on the final page. **Click Finish** on the Final Page and make sure that both the satask.txt and the cfgtask.txt file are on the USB flash drive. If the files are not on the USB flash drive refer to **USB key and Initialization tool interface** located in the *Storwize V7000 Unified Problem Determination Guide* PDF on the DVD.
- d. If you are installing your File Modules on a network with VLANs, you must manually edit the cfgtask.txt file and add the **adapter** and **vlan** parameters as described below.
- e. Proceed to **Initialize the Storwize V7000**.

Important: If InitTool.exe does not ask you for the management IP, file module 1 IP, and file module 2 IP addresses, then you are probably using the wrong version of InitTool.exe.

4. If you are running a non-Windows operating system, you must create the files manually on the USB flash drive. Use table Table 5 on page 16 to determine the appropriate addresses.

The table examples are from the table in “Information required before initializing your system” on page 14.

Table 22. Create two files and enter one line each, adjusted to the values fitting to your environment.

Filename	Content
satask.txt	<pre>satask mknascluster -clusterip 123.123.123.20 -mask 255.255.248.0 -gw 123.123.123.1 -consoleip 123.123.123.10</pre> <p>Where:</p> <ul style="list-style-type: none">• clusterip = primary IP address for the Storwize V7000 system (the block system cluster)• mask = subnet mask• gw = gateway IP address for this subnet• consoleip = management IP address

Table 22. Create two files and enter one line each, adjusted to the values fitting to your environment. (continued)

Filename	Content
cfgtask.txt	<pre> cfginit --ip=123.123.123.10 --netmask=255.255.248.0 --gateway=123.123.123.1 --serviceip1=123.123.123.11 --serviceip2=123.123.123.12 --internalips=169.254.8.1 --storwizeip=123.123.123.20 --adapter=ethX0 --vlan=2 </pre> <p>Where:</p> <ul style="list-style-type: none"> • ip = management IP address • netmask = subnet mask • gateway = gateway IP address • serviceip1 = file module 1 IP address • serviceip2 = file module 2 IP address • internalips = first address of the internal IP address range (always 169.254.8.1) • storwizeip = primary IP address for the Storwize V7000 system • adapter = one of ethX0, ethX1, ethX2 • vlan = a value 2-4094 (the valid range is 0 - 4095, however 0, 1, and 4095 are reserved) <p>Note: By default, the file modules expect no VLAN Tag during installation to enable communication to the Ethernet switch. You can configure the Ethernet switch in "access" mode, as this mode does not require a VLAN tag to be supplied for communication. If the Ethernet switch is configured in "trunk" mode, the cfgtask.txt file needs to be updated with the --vlan <tag ID> parameter. Valid tag IDs are 2 - 4094.</p>

Step 16. Initialize Storwize V7000

Initializing the enclosures is necessary before you can access the system administrative GUI.

About this task

Initialize the Storwize V7000 enclosures.

Procedure

1. Make sure the Storwize V7000 control enclosure completely boots.
You can verify this by checking that the power LED is solid green and the status LED is blinking green on each of the node canisters.
2. Insert the USB flash drive into either USB connector (located at the back of the Storwize V7000 control enclosure) on node canister 1.
While the clustered system is being created, the amber fault LED, on the node canister blinks (the middle light, at the rear of the unit designated by the !).
3. When the amber fault LED stops blinking, proceed to **Initializing the file modules**.

Step 17. Initializing the file modules

You must initialize your file modules before using them for the first time.

Procedure

As soon as you remove the USB flash drive from the control enclosure as instructed by the InitTool.exe tool, do the following procedure:

1. Make sure that the blue identify indicator on each file module is blinking.
2. Insert the USB flash drive into the upper file module so that it becomes node 1. The configuration files that the control enclosure and the initialization tool put onto the USB flash drive are used by the file module to set up the management communication paths in the Storwize V7000 Unified system.
3. Wait for the blue identify indicator on each file module to go out or to start blinking again. This should only take a few minutes, but it might take more than one hour if the Storwize V7000 Unified software level is older than 1.3.2.
4. Insert the USB flash drive into a Windows PC and run the initialization tool executable program that is on the USB flash drive.
5. If this part of the initial setup of the system completes successfully, the initialization tool provides a link to the management GUI where you can view the progress to completion of the initial setup task.
6. If there was a problem with this part of the initial setup, the initialization tool provides the error code and links you to the Information Center page that helps you troubleshoot the problem.
7. If the initial setup does not complete successfully, the management GUI provides the error code and links you to the Information Center page that helps you to troubleshoot the problem.

Step 18. Using the management GUI to complete the initial configuration of the system

Use the management GUI to complete the initial configuration of your system.

About this task

You should have completed the tables in “Information required before starting initial configuration of your system” on page 17 so that you have all of the configuration data ready to complete this task.

Note that the management GUI includes integrated help. If you move your cursor over certain terms or objects, a question mark appears. Moving your cursor over the question mark displays a description of that term. In other areas of the interface, additional information is available through **Learn more** links. You can also get help at any time after the initial configuration of the system by clicking the **Help** link in the top right hand corner of management GUI.

See the **Getting started**, listed under **Learning and tutorials** in the Information Center for a demonstration of this task.

What to do next

You will only be able to access the management GUI after the Initialization Tool part of the Initial setup has completed successfully. If you log on to the management GUI before the initial setup of the system has completed, then you will see an indication of the progress towards completion of initial setup. If you log on to the management GUI for the first time after the initial setup of the system has completed, then you will be shown the licence agreement. Proceed as follows:

1. Log in to the management GUI with the default user ID **admin** and the default password **admin0001**.
2. Read and accept the license agreement.
3. At the System License window, leave the values at 0 if you are not using this feature. For more information about external virtualization go to www.ibm.com/storage/support/storwize/v7000. In the Search support box enter **external virtualization**.
4. Complete the system attributes as required. Refer to Table 6 on page 19.
5. Review the hardware image and verify that it reflects your configuration. Refer to the on-screen instructions and take the recommended actions if necessary. (If there is a red X on the left then click on it to show the error information.) Hover over any red cable or LED to see more information.

Note: Depending on your file module and storage enclosure placement in the frame, the rack locations may not match. You can pull them into the correct location on the picture.

6. It is recommended that you select yes to automatically configure the storage. You can choose to skip this step by selecting **Next** and configure the storage using the GUI at a later time.

Note: You have to configure the storage before using the system.

7. You will be able to decide if you want to configure the following now or wait until later:
 - NAS Services
 - Service Support
8. If you configure NAS services now then at the Public Networks window select the **New Network** button to add one or more public network addresses. Refer to Table 6 on page 19 for information to set up the public network information.
 - The Subnet is entered as the subnet address followed by the CIDR equivalent of the subnet mask (for example 9.11.100.100/32).
 - The Interface drop down menu specifies the network interface (for example, ethX1) to use for attaching the network.

Step 19. Change default passwords

Use the ssh connection to set the superuser, root, and admin passwords.

About this task

For best security practices, it is always recommended that you change the default passwords for the superuser, root, and admin passwords. Make sure you record the new passwords in a secure location.

Note: A good password should be at least eight characters in length and contain a mix of uppercase letters, lowercase letters, and numbers.

Procedure

1. First ssh to the file module management IP address (refer to Table 6 on page 19) using port 22. Log in with user ID **admin** and password **admin0001**.
2. Change the default superuser password for the control enclosure. Issue command `svctask chuser -password superuser_password superuser`, where `superuser_password` is the new superuser password that you want to use. **The password must be a minimum of 6 characters.**

3. Change the default root password for the management node. Issue command `chrootpwd` and follow the prompts to change the password. **The password must be a minimum of 8 characters.**
4. Change the default admin password for the management node. Issue command `chuser admin -p new_password` where `new_password` is the new password that you want to use. **The password must be a minimum of 8 characters.**
5. Type `exit` to close the connection.

Step 20. Check the Storwize V7000 Unified system status

Check the health status of your system.

About this task

To check the health status of the system follow these procedures.

Procedure

1. Log into the management GUI, if not already logged in from the previous step.
2. Check the **Health Status** in the lower right corner of the GUI.
3. If there are any warning or errors noted, hover over the **Monitoring** icon on the left of the page and select **Events**. A listing of errors will be posted.
4. Click on the error for further analysis and details of corrective actions to take.

Step 21. Update

Update the system software if necessary.

About this task

Use the management GUI to install the latest Storwize V7000 Unified software.

Procedure

Select **Settings** and then **System** from the management GUI. From the **System** menu, select **Update**. This page will help you to search for updates, get updates, and install an update.

Configuring call home support

This topic provides instructions for setting up call home support which transmits data to IBM support.

Procedure

1. Go to **Settings > Support** on the management GUI.
2. Click the **Call home** tab and then click the **Edit** button at the bottom of the page.
3. In the **General** group, update the fields:
 - a. Select the **Enable Call Home** check box. This field enables call home to transmit data to IBM support.
 - b. In the **Email server IP address** field, type the IP address of the email server that is used to send and receive call home emails. If Service Support is already configured, this field is populated. Then, click **Test Email Server Connection** and type an email ID to receive a call home test email.

Note: This step only tests the server connectivity and does not save your configuration values. If your configuration settings are done and you want to save your changes, click **OK**.

- c. Complete information about the company name, email addresses, and phone numbers in case a PMR must be created.

Note: If the company name includes an '&' symbol, then in the **Company name** field, use the '\' character before the symbol ('\&'). For example, to display the name "Fred & Wilma" correctly, enter it as "Fred \& Wilma".

For more information about values to be specified in the fields, see Table 7 on page 20 in "Information required before starting initial configuration of your system" on page 17.

4. If the system is behind a proxy, select the **Outbound Connectivity** group and update the fields:
 - a. Select the **Allow automatic access to the Internet** check box.
 - b. The **Proxy Address** and **Proxy Port** fields are enabled. Fill in both fields.
 - c. If the proxy requires authentication, select the **Enable Authentication** check box.
 - d. Complete the information for the **User** and **Password** fields that are now enabled.
 - e. Click **Test Server Connection** to test connectivity to the call home server.

Note: This step only tests the server connectivity and does not save your configuration values. If your configuration settings are done and you want to save your changes, click **OK**.

5. Select the **Advanced** group and update the fields:
 - a. Select the number of **Heart Beat Interval (Days)**, which is used to send small package with general information about the system health. The default is seven days.
 - b. Enter information about the physical location of the system in the **Machine location** field.
 - c. Enter **Special Instructions** that you want IBM Support to know about the system.
6. Click **OK** to save the new configuration.

Note: You can view the status of the attempted call home actions in the **Call Home Log** tab.

Step 22. Enable IBM Tivoli Assist On-Site (AOS)

IBM Tivoli Assist On-Site (AOS) is a lightweight remote support program intended primarily for help desks and support engineers to diagnose and fix problems without the need of any external dependencies. Assist On-Site is based on the IBM Tivoli Remote Control technology.

About this task

Assist On-Site has been developed specifically to meet functionality, security, and privacy requirements of IBM and IBM customers. Support engineers and their customers can run it on various platforms. It currently has a native version for the 32 bit Windows environment and generic Linux compatible operating systems. Assist On-Site uses IBM AES MARS encryption, NTLM authentication, and IBM

intranet authentication for IBM support engineers. Assist On-Site can also support lightweight Rational® Host Access Transformation Services emulator sessions for computers running z/OS® and IBM i.

Assist On-Site provides a launch-in-context feature such that support engineers can start Assist On-Site from within the session of the third-party support tool. For restricted use only, Assist On-Site supports IBM diagnostic tools to function over the Assist On-Site connection for the purpose of debugging hardware devices and IBM software.

The AOS feature is disabled by default To enable it, do the following:

1. From the Storwize V7000 Unified GUI, select **Support**, under **Setting** icon.
2. Click the **AOS** tab.
3. Click the **Edit** button at the bottom.
4. Click **Enable Assist on Site (AOS)**
5. Select either **Lights On** or **Lights Out**. For Storwize V7000 Unified it is recommend to select **Lights Out**. **Lights On** establishes a connection through the local console of the system and thus requires the specific file module to have a keyboard, mouse, and monitor attached for local access and connectivity. **Lights Out** allows for remote support connection to be accepted automatically by the system.
6. Enter any proxy settings if required for AOS.

Note: Establishment of an AOS connection requires access to ports 80, 443, and 8200. The AOS connection provides the ability to make direct outgoing TCP connections, availability of a SOCKS server, or an HTTP proxy.

7. Click on **OK** to complete this procedure.

Step 23. Registering for My Notification

IBM periodically issues updates to products, which help improve overall quality and reliability, through My Notifications.

About this task

Register for My Notifications to establish quick links to important information and to receive daily or weekly notifications of the following product specific information:

- Downloads and drivers
- Flashes
- Forums/discussion groups
- Problem solving information
- Product information and publications

Procedure

To register for My Notifications:

1. Establish an IBM ID and password at <https://www.ibm.com/account/myibm/profile.do?cc=us&lc=en&page=reg>.
2. Then go to <https://www.ibm.com/support/mynotifications> to set up your notification preferences.

Step 24. Next steps

After you have completed the initial configuration of your system here are some pointers to the next configuration steps.

Pointers to the configuration tasks that you may want to do next

- If you wish to change the bonding of the public network ports on the file modules, for example to change the bond mode to 4. It is best to do this before defining the public IP addresses, so that you do not have to detach and reattach the Public networks (ethX0 and ethX1). Thus, client computers will not lose access to files because access has not, yet, been configured. In addition, it is also convenient to increase the maximum Ethernet packet size at the same time. Refer to Changing a bond network interface on a file module, located in the Information Center, for information on changing network bonding.
- If you have additional control enclosures to add to the system refer to Installing additional control enclosures, located in the Information Center.
- If you have connected the second 1 Gbps Ethernet port on each node canister in each control enclosure to your network then you can configure it with the secondary system IP address to give a redundant path for the active management node running on a file module to ssh block storage CLI commands to the main configuration node running on one of the node canisters in one of the control enclosures. Refer to Ethernet connectivity from file modules to the control enclosure, located in the Information Center, for examples of using the **chsystemip** and **chstoragesystem** CLI commands.
- Investigate the Suggested tasks by selecting the **Suggested Tasks** button in the **Home > Overview** panel of the management GUI. For example you can set up the service IP addresses for the node canisters in the control enclosures and you can set up event notifications if you skipped that during initial configuration.
- The Storwize V7000 control enclosure has the ability send an inventory information email to IBM at regular intervals. Refer to Setting up email event notifications and inventory reports using the CLI for how to set up inventory reporting. This topic is listed in the Information Center.
- For other configuration tasks refer to the Configuring section of the Information Center.

Schedule a periodic backup of the TDB:

The Trivial DataBase (TDB) is used to store various types of information used to manage the file systems. It is recommended that you set up a periodic backup of the TDB, so backups are available to support personnel, in the event a TDB becomes lost or corrupted.

1. ssh to the management IP address to access the command line interface. For example, with user ID **admin** and password **admin0001**.
2. Type **mktask BackupTDB --minute 0 --hour 2 --dayOfWeek "*" "**

Note: If you are prompted with following message, the management service is probably not up from the reboot. Wait a few minutes and try again:

```
IBM SONAS management service is stopped
EFSSG0026I Cannot execute commands because Management Service is stopped.
Use startmgtsrv to restart the service
```

The command above schedules a backup of the TDB at 2:00 a.m. every day. If you want to schedule the backup at a different time, change the number following the hour parameter. The 2 in the command can range from 0 (midnight) to 23 (11 p.m.).

Appendix A. Accessibility features for IBM Storwize V7000 Unified

Accessibility features help users who have a disability, such as restricted mobility or limited vision, to use information technology products successfully.

Accessibility features

These are the major accessibility features for the Storwize V7000 Unified:

- You can use screen-reader software and a digital speech synthesizer to hear what is displayed on the screen. HTML documents have been tested using JAWS version 15.0.
- This product uses standard Windows navigation keys.
- Interfaces are commonly used by screen readers.
- Keys are discernible by touch, but do not activate just by touching them.
- Industry-standard devices, ports, and connectors.
- You can attach alternative input and output devices.

The Storwize V7000 Unified online documentation and its related publications are accessibility-enabled. The accessibility features of the online documentation are described in [Viewing information in the information center](#) .

Keyboard navigation

You can use keys or key combinations to perform operations and initiate menu actions that can also be done through mouse actions. You can navigate the Storwize V7000 Unified online documentation from the keyboard by using the shortcut keys for your browser or screen-reader software. See your browser or screen-reader software Help for a list of shortcut keys that it supports.

IBM and accessibility

See the [IBM Human Ability and Accessibility Center](#) for more information about the commitment that IBM has to accessibility.

Appendix B. Where to find the Statement of Limited Warranty

The Statement of Limited Warranty is available in both hardcopy format and in the Storwize V7000 Unified information center.

The Statement of Limited Warranty is shipped (in hardcopy form) with your product. It can also be ordered from IBM (see Table 2 on page xiv for the part number).

Notices

This information was developed for products and services offered in the US. This material might be available from IBM in other languages. However, you may be required to own a copy of the product or product version in that language in order to access it.

IBM may not offer the products, services, or features discussed in this document in other countries. Consult your local IBM representative for information on the products and services currently available in your area. Any reference to an IBM product, program, or service is not intended to state or imply that only that IBM product, program, or service may be used. Any functionally equivalent product, program, or service that does not infringe any IBM intellectual property right may be used instead. However, it is the user's responsibility to evaluate and verify the operation of any non-IBM product, program, or service.

IBM may have patents or pending patent applications covering subject matter described in this document. The furnishing of this document does not grant you any license to these patents. You can send license inquiries, in writing, to:

*IBM Director of Licensing
IBM Corporation
North Castle Drive
Armonk, NY 10504-1785
U.S.A.*

For license inquiries regarding double-byte character set (DBCS) information, contact the IBM Intellectual Property Department in your country or send inquiries, in writing, to:

*Intellectual Property Licensing
Legal and Intellectual Property Law
IBM Japan, Ltd.
19-21, Nihonbashi-Hakozakicho, Chuo-ku
Tokyo 103-8510, Japan*

INTERNATIONAL BUSINESS MACHINES CORPORATION PROVIDES THIS PUBLICATION "AS IS" WITHOUT WARRANTY OF ANY KIND, EITHER EXPRESS OR IMPLIED, INCLUDING, BUT NOT LIMITED TO, THE IMPLIED WARRANTIES OF NON-INFRINGEMENT, MERCHANTABILITY OR FITNESS FOR A PARTICULAR PURPOSE. Some jurisdictions do not allow disclaimer of express or implied warranties in certain transactions, therefore, this statement may not apply to you.

This information could include technical inaccuracies or typographical errors. Changes are periodically made to the information herein; these changes will be incorporated in new editions of the publication. IBM may make improvements and/or changes in the product(s) and/or the program(s) described in this publication at any time without notice.

Any references in this information to non-IBM websites are provided for convenience only and do not in any manner serve as an endorsement of those

websites. The materials at those websites are not part of the materials for this IBM product and use of those websites is at your own risk.

IBM may use or distribute any of the information you provide in any way it believes appropriate without incurring any obligation to you.

Licensees of this program who wish to have information about it for the purpose of enabling: (i) the exchange of information between independently created programs and other programs (including this one) and (ii) the mutual use of the information which has been exchanged, should contact:

*IBM Director of Licensing
IBM Corporation
North Castle Drive, MD-NC119
Armonk, NY 10504-1785
US*

Such information may be available, subject to appropriate terms and conditions, including in some cases, payment of a fee.

The licensed program described in this document and all licensed material available for it are provided by IBM under terms of the IBM Customer Agreement, IBM International Program License Agreement or any equivalent agreement between us.

The performance data discussed herein is presented as derived under specific operating conditions. Actual results may vary.

Information concerning non-IBM products was obtained from the suppliers of those products, their published announcements or other publicly available sources. IBM has not tested those products and cannot confirm the accuracy of performance, compatibility or any other claims related to non-IBM products. Questions on the capabilities of non-IBM products should be addressed to the suppliers of those products.

Statements regarding IBM's future direction or intent are subject to change or withdrawal without notice, and represent goals and objectives only.

All IBM prices shown are IBM's suggested retail prices, are current and are subject to change without notice. Dealer prices may vary.

This information is for planning purposes only. The information herein is subject to change before the products described become available.

This information contains examples of data and reports used in daily business operations. To illustrate them as completely as possible, the examples include the names of individuals, companies, brands, and products. All of these names are fictitious and any similarity to the names and addresses used by an actual business enterprise is entirely coincidental.

COPYRIGHT LICENSE:

This information contains sample application programs in source language, which illustrate programming techniques on various operating platforms. You may copy, modify, and distribute these sample programs in any form without payment to IBM, for the purposes of developing, using, marketing or distributing application

programs conforming to the application programming interface for the operating platform for which the sample programs are written. These examples have not been thoroughly tested under all conditions. IBM, therefore, cannot guarantee or imply reliability, serviceability, or function of these programs. The sample programs are provided "AS IS", without warranty of any kind. IBM shall not be liable for any damages arising out of your use of the sample programs.

If you are viewing this information softcopy, the photographs and color illustrations may not appear.

Trademarks

IBM, the IBM logo, and [ibm.com](http://www.ibm.com)[®] are trademarks or registered trademarks of International Business Machines Corp., registered in many jurisdictions worldwide. Other product and service names might be trademarks of IBM or other companies. A current list of IBM trademarks is available on the web at Copyright and trademark information at www.ibm.com/legal/copytrade.shtml.

Adobe, the Adobe logo, PostScript, and the PostScript logo are either registered trademarks or trademarks of Adobe Systems Incorporated in the United States, and/or other countries.

Linux and the Linux logo is a registered trademark of Linus Torvalds in the United States, other countries, or both.

Microsoft, Windows, and the Windows logo are trademarks of Microsoft Corporation in the United States, other countries, or both.

Other product and service names might be trademarks of IBM or other companies.

Electronic emission notices

This section contains the electronic emission notices or statements for the United States and other countries.

Federal Communications Commission (FCC) statement

This explains the Federal Communications Commission's (FCC's) statement.

This equipment has been tested and found to comply with the limits for a Class A digital device, pursuant to Part 15 of the FCC Rules. These limits are designed to provide reasonable protection against harmful interference when the equipment is operated in a commercial environment. This equipment generates, uses, and can radiate radio frequency energy and, if not installed and used in accordance with the instruction manual, might cause harmful interference to radio communications. Operation of this equipment in a residential area is likely to cause harmful interference, in which case the user will be required to correct the interference at his own expense.

Properly shielded and grounded cables and connectors must be used in order to meet FCC emission limits. IBM is not responsible for any radio or television interference caused by using other than recommended cables and connectors, or by unauthorized changes or modifications to this equipment. Unauthorized changes or modifications could void the user's authority to operate the equipment.

This device complies with Part 15 of the FCC Rules. Operation is subject to the following two conditions: (1) this device might not cause harmful interference, and (2) this device must accept any interference received, including interference that might cause undesired operation.

Industry Canada compliance statement

This Class A digital apparatus complies with Canadian ICES-003.

Cet appareil numérique de la classe A est conform à la norme NMB-003 du Canada.

Australia and New Zealand Class A Statement

Attention: This is a Class A product. In a domestic environment this product might cause radio interference in which case the user might be required to take adequate measures.

European Union Electromagnetic Compatibility Directive

This product is in conformity with the protection requirements of European Union (EU) Council Directive 2004/108/EC on the approximation of the laws of the Member States relating to electromagnetic compatibility. IBM cannot accept responsibility for any failure to satisfy the protection requirements resulting from a non-recommended modification of the product, including the fitting of non-IBM option cards.

Attention: This is an EN 55022 Class A product. In a domestic environment this product might cause radio interference in which case the user might be required to take adequate measures.

Responsible Manufacturer:

International Business Machines Corp.
New Orchard Road
Armonk, New York 10504
914-499-1900

European community contact:

IBM Deutschland GmbH
Technical Regulations, Department M372
IBM-Allee 1, 71139 Ehningen, Germany
Tele: +49 (0) 800 225 5423 or +49 (0) 180 331 3233
Email: halloibm@de.ibm.com

Germany Electromagnetic Compatibility Directive

Deutschsprachiger EU Hinweis: Hinweis für Geräte der Klasse A EU-Richtlinie zur Elektromagnetischen Verträglichkeit

Dieses Produkt entspricht den Schutzanforderungen der EU-Richtlinie 2004/108/EG zur Angleichung der Rechtsvorschriften über die elektromagnetische Verträglichkeit in den EU-Mitgliedsstaaten und hält die Grenzwerte der EN 55022 Klasse A ein.

Um dieses sicherzustellen, sind die Geräte wie in den Handbüchern beschrieben zu installieren und zu betreiben. Des Weiteren dürfen auch nur von der IBM empfohlene Kabel angeschlossen werden. IBM übernimmt keine Verantwortung für die Einhaltung der Schutzanforderungen, wenn das Produkt ohne Zustimmung der IBM verändert bzw. wenn Erweiterungskomponenten von Fremdherstellern ohne Empfehlung der IBM gesteckt/eingebaut werden.

EN 55022 Klasse A Geräte müssen mit folgendem Warnhinweis versehen werden:

“Warnung: Dieses ist eine Einrichtung der Klasse A. Diese Einrichtung kann im Wohnbereich Funk-Störungen verursachen; in diesem Fall kann vom Betreiber verlangt werden, angemessene Maßnahmen zu ergreifen und dafür aufzukommen.”

Deutschland: Einhaltung des Gesetzes über die elektromagnetische Verträglichkeit von Geräten

Dieses Produkt entspricht dem “Gesetz über die elektromagnetische Verträglichkeit von Geräten (EMVG).” Dies ist die Umsetzung der EU-Richtlinie 2004/108/EG in der Bundesrepublik Deutschland.

Zulassungsbescheinigung laut dem Deutschen Gesetz über die elektromagnetische Verträglichkeit von Geräten (EMVG) (bzw. der EMC EG Richtlinie 2004/108/EG) für Geräte der Klasse A

Dieses Gerät ist berechtigt, in Übereinstimmung mit dem Deutschen EMVG das EG-Konformitätszeichen - CE - zu führen.

Verantwortlich für die Einhaltung der EMV Vorschriften ist der Hersteller:

International Business Machines Corp.
New Orchard Road
Armonk, New York 10504
Tel: 914-499-1900

Der verantwortliche Ansprechpartner des Herstellers in der EU ist:

IBM Deutschland GmbH
Technical Regulations, Abteilung M372
IBM-Allee 1, 71139 Ehningen, Germany
Tele: +49 (0) 800 225 5423 or +49 (0) 180 331 3233
Email: halloibm@de.ibm.com

Generelle Informationen:

Das Gerät erfüllt die Schutzanforderungen nach EN 55024 und EN 55022 Klasse A.

People's Republic of China Class A Statement

中华人民共和国“A类”警告声明

声明

此为A级产品，在生活环境中，该产品可能会造成无线电干扰。在这种情况下，可能需要用户对其干扰采取切实可行的措施。

Taiwan Class A compliance statement

警告使用者：
這是甲類的資訊產品，在居住的環境中使用時，可能會造成射頻干擾，在這種情況下，使用者會被要求採取某些適當的對策。

Taiwan Contact Information

This topic contains the product service contact information for Taiwan.

IBM Taiwan Product Service Contact Information:
IBM Taiwan Corporation
3F, No 7, Song Ren Rd., Taipei Taiwan
Tel: 0800-016-888

台灣IBM 產品服務聯絡方式：
台灣國際商業機器股份有限公司
台北市松仁路7號3樓
電話：0800-016-888

f2c00790

Japan VCCI Council Class A statement

This explains the Japan Voluntary Control Council for Interference (VCCI) statement.

この装置は、クラス A 情報技術装置です。この装置を家庭環境で使用すると電波妨害を引き起こすことがあります。この場合には使用者が適切な対策を講ずるよう要求されることがあります。

VCCI-A

Japan Electronics and Information Technology Industries Association Statement

This statement explains the Japan JIS C 61000-3-2 product wattage compliance.

(一社) 電子情報技術産業協会 高調波電流抑制対策実施
要領に基づく定格入力電力値：Knowledge Center を参照

This statement explains the Japan Electronics and Information Technology Industries Association (JEITA) statement for products less than or equal to 20 A per phase.

高周波電流規格 JIS C 61000-3-2 適合品

This statement explains the JEITA statement for products greater than 20 A, single phase.

高周波電流規格 JIS C 61000-3-2 準用品

本装置は、「高圧又は特別高圧で受電する需要家の高調波抑制対策ガイドライン」対象機器（高調波発生機器）です。

- ・回路分類 : 6 (単相、PFC回路付)
- ・換算係数 : 0

This statement explains the JEITA statement for products greater than 20 A per phase, three-phase.

高周波電流規格 JIS C 61000-3-2 準用品

本装置は、「高圧又は特別高圧で受電する需要家の高調波抑制対策ガイドライン」対象機器（高調波発生機器）です。

- ・回路分類 : 5 (3相、PFC回路付)
- ・換算係数 : 0

Korean Communications Commission Class A Statement

This explains the Korean Communications Commission (KCC) statement.

이 기기는 업무용(A급)으로 전자파적합기기로서 판매자 또는 사용자는 이 점을 주의하시기 바라며, 가정외의 지역에서 사용하는 것을 목적으로 합니다.

Russia Electromagnetic Interference Class A Statement

This statement explains the Russia Electromagnetic Interference (EMI) statement.

ВНИМАНИЕ! Настоящее изделие относится к классу А.
В жилых помещениях оно может создавать радиопомехи, для снижения которых необходимы дополнительные меры



Printed in USA

GC27-5945-07

