

IBM Storage DS8000 (10th Generation)
10.0

Introduction and Planning Guide



Note

Before using this information and the product it supports, read the information in [“Safety and environmental notices”](#) on page 176 and [“Notices”](#) on page 175.

This edition applies to version 10.0.0 of IBM® DS8000® and to all subsequent releases and modifications until otherwise indicated in new editions.

This edition replaces SC27-9560-07.

© **Copyright International Business Machines Corporation 2019, 2024.**

US Government Users Restricted Rights – Use, duplication or disclosure restricted by GSA ADP Schedule Contract with IBM Corp.

Contents

About this book.....	vii
Who should use this book.....	vii
Conventions and terminology.....	vii
Publications and related information.....	vii
Feedback.....	ix
Summary of changes	xi
Chapter 1. Overview.....	1
Machine types.....	2
Hardware.....	2
DS8A00 model A01 configuration.....	4
DS8A00 model A05 and E05 configuration.....	4
Capacity limits.....	5
I/O enclosures.....	5
Processor nodes.....	6
Management console.....	6
Ethernet switches.....	6
Power.....	6
Functions.....	7
Updating code levels.....	9
Logical configuration.....	10
Logical configuration with DS8000 Storage Management GUI.....	10
Logical configuration with DS CLI.....	11
RAID implementation.....	13
Logical subsystems.....	14
Allocation methods.....	15
Management interfaces.....	16
DS8000 Storage Management GUI.....	16
DS command-line interface	16
RESTful API.....	17
IBM Spectrum Control.....	17
IBM Copy Services Manager.....	17
Supported web browsers.....	18
Chapter 2. Hardware features.....	21
Management console.....	50
Hardware specifics.....	51
Storage system structure.....	51
Flash drives.....	51
Drive maintenance policy.....	52
Host attachment overview.....	52
I/O load balancing.....	54
Storage consolidation.....	55
Count key data.....	55
Fixed block.....	55
T10 DIF support.....	55
Logical volumes.....	56
Allocation, deletion, and modification of volumes.....	56
LUN calculation.....	57

Extended address volumes for CKD.....	58
Quick initialization.....	58
Chapter 3. Data management features.....	61
Transparent cloud tiering.....	61
Dynamic volume expansion.....	62
Count key data and fixed block volume deletion prevention	63
Thin provisioning.....	63
ESE capacity controls for thin provisioning.....	64
IBM Easy Tier.....	65
VMware vStorage API for Array Integration support	67
Performance for IBM Z	68
Copy Services.....	69
Disaster recovery through Copy Services.....	76
Resource groups for Copy Services scope limiting.....	77
Comparison of Copy Services features.....	79
Securing data.....	79
Chapter 4. Physical configuration.....	81
Configuration controls.....	81
Determining physical configuration features.....	81
Selecting storage features.....	82
Storage enclosures and drives.....	82
Storage-enclosure fillers.....	83
Storage feature configuration rules.....	83
Raw and usable capacity.....	84
Selecting I/O adapter features.....	86
I/O enclosures.....	86
Fibre Channel host adapters and cables.....	87
zHyperLink adapters and cables.....	90
Transparent cloud tiering adapters.....	91
Flash RAID adapters.....	91
Selecting processor node features.....	92
Processor licenses.....	92
Selecting processor memory features.....	92
System memory.....	92
Selecting power features.....	93
Power cords.....	93
Power feature configuration rules.....	94
Selecting other configuration features.....	95
BSMI certificate (Taiwan).....	95
Chapter 5. Licensed functions.....	97
Licensed function indicators.....	97
License scope.....	97
Ordering licensed functions.....	98
Rules for ordering licensed functions.....	98
Base Function license.....	99
Encryption Authorization.....	100
IBM Easy Tier.....	100
Operating environment license.....	101
Thin provisioning	101
z-synergy Services license.....	101
High Performance FICON for z Systems.....	102
IBM HyperPAV	102
Parallel Access Volumes	102
z/OS Distributed Data Backup.....	103

zHyperLink.....	103
IBM Fibre Channel Endpoint Security.....	103
Transparent cloud tiering.....	103
Copy Services license.....	104
Remote mirror and copy functions.....	105
FlashCopy function (point-in-time copy).....	105
Safeguarded Copy.....	105
Local Data-at-Rest Encryption license.....	106
Chapter 6. Delivery and installation requirements.....	107
Delivery requirements.....	107
Acclimation.....	107
Shipment weights and dimensions.....	108
Receiving delivery.....	108
Installation site requirements.....	109
Planning for floor and space requirements.....	109
Planning for power requirements.....	129
Planning for environmental requirements.....	134
Planning for safety.....	139
Planning for network and communications requirements.....	140
Chapter 7. Storage complex setup.....	143
Company information.....	143
Management console network settings.....	143
Remote support settings.....	144
Notification settings.....	144
Control switch settings.....	145
Chapter 8. Data migration.....	147
Selecting a data migration method.....	147
Chapter 9. Security.....	149
Encryption.....	149
Encryption-key servers.....	149
Key lifecycle managers.....	150
Planning for full-disk encryption activation.....	150
User accounts and passwords.....	151
User accounts.....	151
Service accounts.....	152
Planning for NIST SP 800-131A security conformance.....	153
Remote authentication.....	154
Chapter 10. License activation and management.....	157
Planning your licensed functions.....	157
Activation of licensed functions.....	158
Activating licensed functions.....	158
Scenarios for managing licensing.....	159
Adding storage to your machine.....	159
Managing a licensed feature.....	160
Appendix A. Accessibility features	161
Appendix B. Warranty information.....	163
Appendix C. IBM equipment and documents	165
Installation components.....	165

Customer components.....	166
Service components.....	166
Appendix D. Configuration worksheets.....	167
Appendix E. Compliance standards.....	169
Appendix F. European Union General Data Protection Regulation Considerations.....	171
Appendix G. Data privacy.....	173
Notices.....	175
Trademarks.....	176
Homologation statement.....	176
Safety and environmental notices.....	176
Safety notices and labels.....	176
Vendor-specific uninterruptible power supply safety statements.....	187
Environmental notices.....	188
Electromagnetic compatibility notices.....	189
Index.....	193

About this book

This book describes how to plan for a new installation of the IBM Storage DS8000 (10th Generation). It includes information about planning requirements and considerations, customization guidance, and configuration worksheets.

Who should use this book

This book is intended for personnel that are involved in planning. Such personnel include IT facilities managers, individuals responsible for power, cooling, wiring, network, and general site environmental planning and setup.

Conventions and terminology

Different typefaces are used in this guide to show emphasis, and various notices are used to highlight key information.

The following typefaces are used to show emphasis:

Typeface	Description
Bold	Text in bold represents menu items.
bold monospace	Text in bold monospace represents command names.
<i>Italics</i>	Text in italics is used to emphasize a word. In command syntax, it is used for variables for which you supply actual values, such as a default directory or the name of a system.
Monospace	Text in monospace identifies the data or commands that you type, samples of command output, examples of program code or messages from the system, or names of command flags, parameters, arguments, and name-value pairs.

These notices are used to highlight key information:

Notice	Description
Note	These notices provide important tips, guidance, or advice.
Important	These notices provide information or advice that might help you avoid inconvenient or difficult situations.
Attention	These notices indicate possible damage to programs, devices, or data. An attention notice is placed before the instruction or situation in which damage can occur.

Publications and related information

Product guides, other IBM publications, and websites contain information that relates to the IBM DS8000 series.

To view a PDF file, you need Adobe Reader. You can download it at no charge from the [Adobe website \(get.adobe.com/reader/\)](https://get.adobe.com/reader/).

Online documentation

Go to IBM Documentation (www.ibm.com/docs) to find the most current information.

Publications

You can order or download individual publications (including previous versions) that have an order number from the IBM Publications Center website (www.ibm.com/resources/publications). Publications without an order number are available on the documentation CD or can be downloaded here.

Title	Description	Order number
IBM Storage DS8000 (10th Generation) Introduction and Planning Guide	This publication provides an overview of the new IBM Storage DS8000 (10th Generation), the most current storage system in the DS8000 series.	V10.0 G10-I53-00.pdf
IBM Storage DS8000 (10th Generation) Command-Line Interface (CLI) User's Guide	This publication describes how to use the IBM Storage DS8000 (10th Generation) command-line interface (CLI) to manage configuration and write customized scripts for a host system. It also includes a complete list of CLI commands with descriptions and example usage.	V10.0 G10-C53-00.pdf

Title	Location
<i>IBM Warranty Information for DS8000 series</i>	IBM Support Portal website
<i>IBM Safety Notices</i>	IBM Systems Safety Notices
<i>IBM Systems Environmental Notices</i>	IBM Systems Safety Notices
<i>International Agreement for Acquisition of Software Maintenance (Not all software will offer Software Maintenance under this agreement.)</i>	IBM Support Portal website
<i>IBM License Agreement for Machine Code</i>	https://www.ibm.com/support/pages/node/631363

See the Agreements and License Information CD that was included with the DS8000 series for the following documents:

- License Information
- Notices and Information
- Supplemental Notices and Information

Related websites

View the websites in the following table to get more information about DS8000 series.

Table 3. DS8000 series related websites

Title	Description
IBM Support Portal website	Find support-related information such as downloads, documentation, troubleshooting, and service requests and PMRs.
IBM Directory of Worldwide Contacts website (www.ibm.com/planetwide)	Find contact information for general inquiries, technical support, and hardware and software support by country.
IBM DS8000 series website (www.ibm.com/servers/storage/disk/ds8000)	Find product overviews, details, resources, and reviews for the DS8000 series.
IBM Redbooks® (www.redbooks.ibm.com/)	Find technical information developed and published by IBM International Technical Support Organization (ITSO).
IBM System Storage Interoperation Center (SSIC) website(www-03.ibm.com/systems/support/storage/ssic/interoperability.was)	Find information about host system models, operating systems, adapters, and switches that are supported by the DS8000 series.
IBM Entitled Systems Support (ESS) website	Download licensed machine code (LMC) feature keys that you ordered for your DS8000 storage systems.
IBM Fix Central (www-933.ibm.com/support/fixcentral)	Download utilities such as the IBM Easy Tier® Heat Map Transfer utility.
IBM Java™ SE (JRE) (www.ibm.com/developerworks/java/jdk)	Download IBM versions of the Java SE Runtime Environment (JRE), which is often required for IBM products.
IBM Security Guardium Key Lifecycle Manager online product documentation (www.ibm.com/docs/en/sgklm)	This online documentation provides information about IBM Security Guardium Key Lifecycle Manager, which you can use to manage encryption keys and certificates.
IBM Spectrum Control online product documentation in IBM Documentation (www.ibm.com/docs/spectrum-control)	This online documentation provides information about IBM Spectrum Control, which you can use to centralize, automate, and simplify the management of complex and heterogeneous storage environments including DS8000 storage systems and other components of your data storage infrastructure.
DS8900F Code Bundle Information website (www.ibm.com/support/docview.wss?uid=ibm11072022)	Find information about code bundles for DS8900F. The version of the currently active installed code bundle displays with the DS CLI <code>ver</code> command when you specify the <code>-l</code> parameter.

Sending comments

Your feedback is important in helping to provide the most accurate and highest quality information.

Procedure

To submit any comments about this publication or any other IBM storage product documentation:

- Send your comments by email to ibmdocs@us.ibm.com. Be sure to include the following information:
 - Exact publication title and version
 - Publication form number (for example, GA32-1234-00)
 - Page, table, or illustration numbers that you are commenting on

- A detailed description of any information that should be changed

Summary of changes

IBM Storage DS8000® (10th Generation) Version 10, Release 0 introduces the following new features.

Version 10, Release 0

This table provides the current technical changes and enhancement to the IBM Storage DS8000® (10th Generation).

Function	Description
Improved Bandwidth with PCIe Gen4	<p>The DS8000 10th generation is designed with PCIe Gen4 enabled infrastructure. This is a significant upgrade over the PCIe Gen3 connectivity in the DS8900F, providing double the internal bandwidth across key components:</p> <ul style="list-style-type: none"> • New Power Servers with PCIe Gen4 support • New IO Bays with PCIe Gen4 • New zHyperlink and HPFE RAID adapters
Next Generation zHyperlink Adapter	<p>The zHyperlink adapter on the DS8000 G10 is built on PCIe Gen4 technology and will support connections at up to Gen4 speeds. The latency of the new adapter is reduced for reads and writes. The throughput of a single link on the new adapter is also improved.</p> <p>With the reduced latency provided by the new adapter it is also now possible to support larger read sizes. The default maximum read size supported is now 16 KB and z/OS provides the ability to increase this up to 32 KB if needed for specific workloads.</p>
Next Generation High Performance Flash Enclosure	<p>The next generation High Performance Flash Enclosure includes a new RAID Adapter with improved performance and uses NVMe Flash drives with RAID6 and RAID10 for data protection.</p> <p>The RAID functionality has been moved from the ASIC used in the HPFE Gen2 and now runs on dedicated processors within the RAID adapter. The HPFE Gen3 provides improved bandwidth and IOPS compared to the HPFE Gen2.</p>
Support for NVMe drives including IBM FlashCore Modules	<p>The new high-performance flash enclosure pairs are compatible with both industry-standard NVMe flash drive media and IBM FlashCore Modules (FCM), which feature built-in compression. Given the enhanced performance offered by the latest RAID adapters and NVMe drives, it's anticipated that users transitioning from earlier generation storage systems will have the option to upgrade to larger drive sizes compared to their current setup. To verify that a specific configuration will satisfy workload requirements, use the IBM Storage Modeller.</p>

Function	Description
Compression with IBM FlashCore Modules	<p>The DS8000 10th generation supports compression for both CKD and FB data when configured with IBM FlashCore Modules. Implemented completely in hardware with no processor intervention means that these added benefits do not slow down the rest of the storage system.</p>
Improved Capacity Scalability	<p>The DS8000 10th generation system provides double the capacity scalability compared to previous generation systems when configured with small extents. The maximum usable capacity of the A05 increases from 2 PiB to 4 PiB (1.15 PiB to 4.3 PiB for CKD) and for the A01 this increases from 512 TiB to 1 PiB (551 TiB to 1.08 PiB for CKD).</p> <p>The maximum provisioned capacity is also doubled enabling larger provisioned capacity for thin provisioning and Safeguarded Copy. The maximum provisioned capacity of the A05 increases from 4 PiB to 8 PiB (3.68 PiB to 7.18 PiB for CKD) and for the A01 this increases from 1 PiB to 2 PiB (971 TiB to 1.78 PiB for CKD).</p>
Security	<ul style="list-style-type: none"> • Improved Security for From Local Key Manager to PKS for Local DAR Key Manager <ul style="list-style-type: none"> – The DS8000 10th generation will exploit the IBM POWER PKS feature which creates an encrypted non-volatile store. • Data at Rest Encryption and FIPS 140-3 <ul style="list-style-type: none"> – All drives in the DS8000 G10 support Advanced Encryption Standard (AES), data-at-rest encryption, and are FIPS 140-3 compliant.
Simplification	<p>For the 10th generation of DS8000, the following changes will be made to simplify the configuration and operation of the system supported:</p> <ul style="list-style-type: none"> • Simplify Configuration in GUI/CLI • Remove duplicate options • Remove extended remote copy (XRC) support • Move code stack to SW with abstraction layer to HW • Removal of custom HW/FW and replace with standard HW/FW shown below: <ul style="list-style-type: none"> – POWER 9 based HMC – Rack Mounted Ethernet Switches

Chapter 1. Overview

The IBM Storage DS8000 is distinguished by its exceptional performance and scalability, unmatched cybersecurity, and resilience. It's designed to support critical workloads across hybrid multi-cloud environments.

The DS8000 10th generation family represents the newest iteration of DS8000 technology. It embodies two decades of DS8000 experience and a quarter-century of Enterprise Storage Server architecture, shaping the future of enterprise storage. IBM Storage has developed a new-generation solution at the forefront of enterprise technology by creating a family that addresses market needs for capacity, size, security, and synergy.

The DS8000 10th generation is engineered for eight-nines (99.999999%) availability, providing clients complete confidence in their cyber resilience.

The following classes are offered:

Flexibility Class DS8A10

The DS8A10 Flexibility Class is a perfect balance between performance, capacity and cost to support a variety of workloads.

IBM DS8A10 Model A01

The IBM DS8A10 Model A01 is a racked flexibility-class solution delivering the following features:

- Two 8-core processors per CEC for a total of 20 cores per system
- Power 9+ PCIe Gen 4 CECs
- A maximum of 192 flash cards (four HPFE Gen 3 pa)
- 256 GB or 512 GB processor memory per system
- Up to 16 host adapters or 64 ports
- 42U, 19-inch rack
- Single-phase and three-phase support

Agility Class DS8A50

The DS8A50 Agility Class is efficiently designed to consolidate your mission-critical workloads for IBM Z, IBM LINUX, IBM Power and distributed environments.

IBM DS8A50 Model A05

The IBM DS8A50 Model A05 is a racked agility-class solution delivering the following features:

- Two 20-core processor per CEC for a total of 40-core per system
- Power 9+ PCIe Gen 4 CECs
- A maximum of 192 flash cards (four HPFE Gen 3)
- 1 TB, 2 TB or 3.5 TB processor memory per system
- Up to 16 host adapters or 64 ports
- 42U, 19-inch rack
- Single-phase and three-phase support

IBM DS8A00 Model E05

The IBM DS8A00 Model E05 is an expansion for DS8A50 Model A05 that can be attached to a 40-core system to enable:

- Up to 192 flash cards (four HPFE Gen 3) for a total of 384 flash drives (eight HPFE Gen 3) per system
- Up to 16 host adapters or 64 ports for a total of 32 host adapters or 128 ports per system
- 42U, 19-inch rack

- Single-phase and three-phase support

Machine types overview

There are several machine type options available for the IBM Storage DS8000® (10th Generation). Order a hardware machine type for the storage system and a corresponding function authorization machine type model for the licensed functions that are planned for use.

The following table lists the available hardware machine types and their corresponding function authorization machine types.

Table 4. Available hardware and function-authorization machine types that support all-flash system types

Hardware		Licensed functions	
Hardware machine type	Available hardware models	Corresponding function authorization machine type	Available function authorization models
5341	A01	9031	FFA
	A05		
	E05		

The machine types for the DS8000 series specify the service warranty period. The warranty is used for service entitlement checking when notifications for service are called home. All DS8000 series models report 2107 as the machine type to attached host systems.

Hardware

The architecture of the IBM DS8000 series is based on three major elements that provide function specialization and three tiers of processing power.

Figure 1 on page 3 illustrates the following elements:

- Host adapters manage external I/O interfaces that use Fibre Channel protocols for host-system attachment and for replicating data between storage systems.
- A pair of high-performance redundant active-active Power® servers is functionally positioned between the adapters and a key feature of the architecture.

The internal Power servers support the bulk of the processing to be done in the storage system. Each Power server has multiple processor cores. The cores are managed as a symmetric multiprocessing (SMP) pool of shared processing power to process the work that is done on the Power server. Each Power server runs an AIX® kernel that manages the processors, manages processor memory as a data cache, and more. For more information, see *IBM DS8000 Architecture and Implementation* on the [IBM Redbooks \(www.redbooks.ibm.com/\)](http://www.redbooks.ibm.com/)

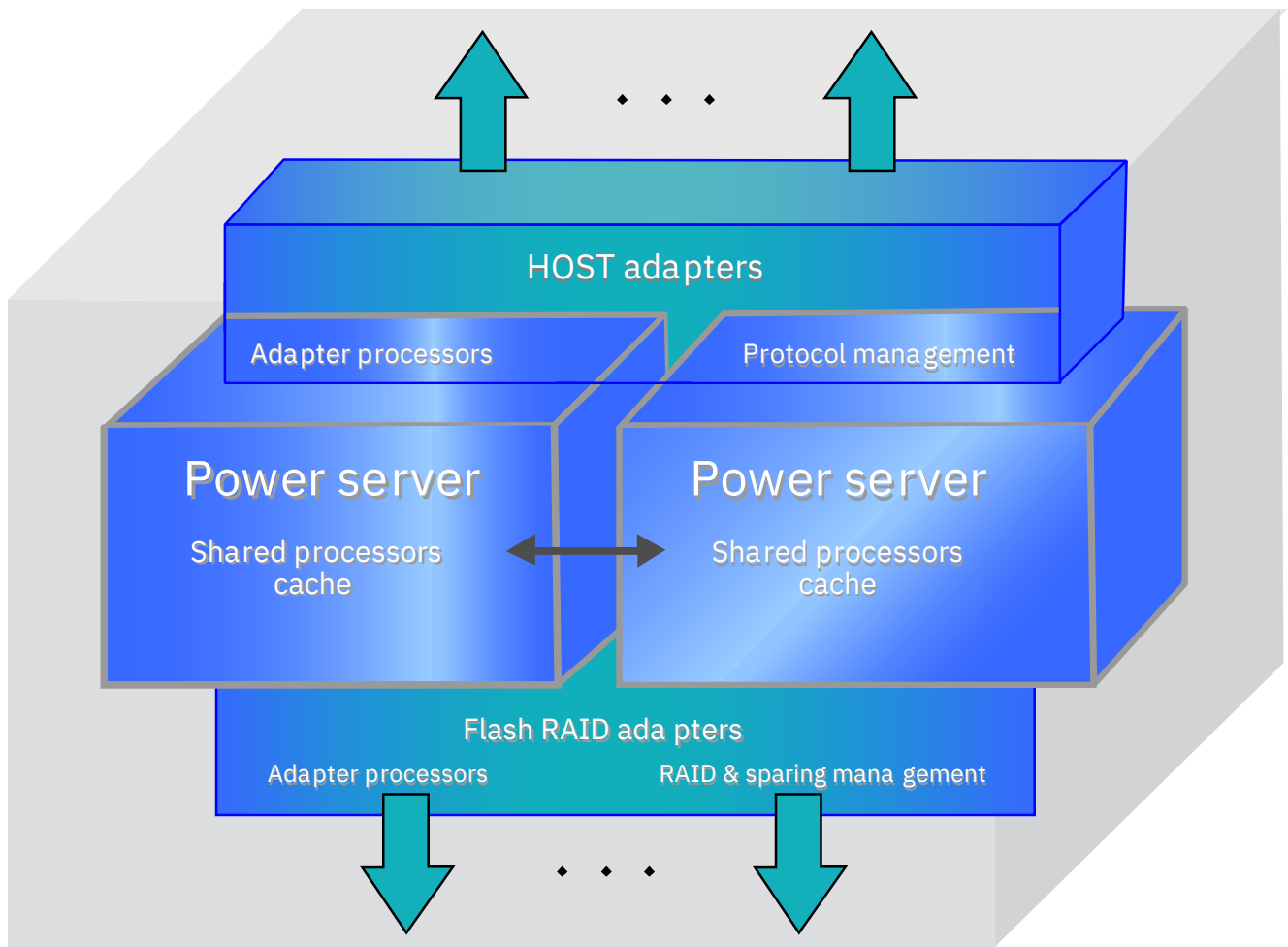

Figure 1. DS8000 series architecture

The DS8000 series architecture has the following major benefits.

- Server foundation
 - Promotes high availability and high performance by using field-proven Power servers
 - Reduces custom components and design complexity
 - Positions the storage system to reap the benefits of server technology advances
- Operating environment
 - Promotes high availability and provides a high-quality base for the storage system software through a field-proven AIX operating-system kernel
 - Provides an operating environment that is optimized for Power servers, including performance and reliability, availability, and serviceability
 - Provides shared processor (SMP) efficiency
 - Reduces custom code and design complexity
 - Uses Power firmware and software support for networking and service functions

DS8A00 model A01

The DS8A00 model A01 is a racked storage system delivering the following features:

- IBM Power 9+ PCIe Gen 4 processor nodes
- One 10-core processors per node for a total of 20 cores per system
- 256 GB or 512 GB system memory
- A maximum of 192 NVMe Flash Drives and four HPFE Gen3 enclosure pairs
- Up to 16 host adapters providing 64 ports
- Up to 4 zHyperlink adapters providing 4 zHyperlink ports
- 42U, 19-inch rack with single-phase and three-phase support

The following tables list the hardware components and maximum capacities that are supported for the model A01.

Table 5. Components for model A01

Processors	System memory	Processor memory	I/O enclosures	Host adapters (4 port)	HPFE Gen3 enclosure pairs	Expansion frames
10-core	256 GB	256 GB	1 or 2	2 - 16	1 - 4	0
20-core	512 GB	512 GB	1 - 4	2 - 32	1 - 8	0 - 1

Table 6. Maximum capacity for model A01

Processors	System memory	Maximum 2.5-in. Flash Tier 0, Flash Tier 1, or Flash Tier 2 drives	Maximum storage capacity for 2.5-in. Flash Tier 0, Flash Tier 1, or Flash Tier 2 drives
10-core	512 GB	192	2.9 PB
20-core	1024 GB	384	5.9 PB

DS8A00 model A05 and E05

The DS8A00 model A05 is a racked storage system delivering the following features:

- IBM Power 9+ PCIe Gen 4 processor nodes
- Two 10-core processors per node for a total of 40 cores per system
- 1 TB, 2 TB, or 3.5 TB system memory
- A maximum of 192 NVMe Flash Drives and four HPFE Gen3 enclosure pairs
- Up to 16 host adapters providing 64 ports
- Up to 8 zHyperlink adapters providing 8 zHyperlink ports
- 42U, 19-inch rack with single-phase and three-phase support

The Model E05 is an expansion frame that can be attached to a multiframe system to provide:

- Up to 192 additional NVMe Flash Drives and four HPFE Gen3 enclosure pairs for a total of 384 Flash drives and eight HPFE Gen3 enclosure pairs
- Up to 16 additional host adapters providing 64 ports for a total of 32 host adapters and 128 ports per system
- Up to 8 additional zHyperlink adapters with a maximum of 10 zHyperlink ports per system
- 42U, 19-inch rack with single-phase and three-phase support

The following tables list the hardware components and maximum capacities that are supported for the models A05 and E05, depending on the amount of memory that is available.

Table 7. Components for models A05 and E05

Processors	System memory	Processor memory	I/O enclosures	Host adapters (4 port)	HPFE Gen3 enclosure pairs	Expansion frames
40-core	1TB, 2TB, or 3.5 TB	2176 GB	1 - 4	2 - 16	1 - 8	0 - 1

Table 8. Maximum capacity for models A05 and E05

Processors	System memory	Maximum 2.5-in. Flash Tier 0, Flash Tier 1, or Flash Tier 2 drives	Maximum storage capacity for 2.5-in. Flash Tier 0, Flash Tier 1, or Flash Tier 2 drives
22-core	4352 GB	384	5.9 PB

Note: Maximum usable and provisioned capacity of the storage system differ depending on storage type (CKD, FB) and system memory. For more information, see [“Capacity limits”](#) on page 5.

DS8A05 expansion frame (model E05) overview

The DS8A05 supports one expansion frame (model E05) that can be added to a base frame (model A05).

The expansion frame includes an intelligent rack PDU (iPDU) pair, I/O enclosures, and up to four High Performance Flash Enclosure Gen3 pairs.

Capacity limits

Maximum usable and provisioned capacity of the storage system differ depending on storage type (CKD, FB) and system memory.

The following table lists the maximum capacities.

Table 9. Maximum usable and provisioned capacity

Model	Volume Type	Large extents - maximum Provisioned capacity	Large extents - maximum Usable capacity	Small extents - maximum Provisioned capacity	Small extents - maximum Usable capacity
A01 (single frame)	FB	8,192 TiB	8,192 TiB	2,048 TiB	1,024 TiB
A01 (single frame)	CKD	7,304 TiB	7,304 TiB	1,826 TiB	1,102 TiB
A05 (multi frame)	FB	~32,768 TiB	32,768 TiB	~8,192 TiB	4,096 TiB
A05 (multi frame)	CKD	~29,216 TiB	29,216 TiB	~7,304 TiB	4,410 TiB

I/O enclosures

The I/O enclosure is a bridge between the processor nodes and the customer data, both from the flash drives and the host systems.

The I/O enclosure uses PCIe interfaces to connect I/O adapters in the I/O enclosure to both processor nodes. A PCIe device is an I/O adapter or a processor node.

To improve I/O operations per second (IOPS) and sequential read/write throughput, the I/O enclosure is connected to each processor node with a point-to-point connection.

The I/O enclosure contain the following adapters:

Flash interface connectors

Interface connector that provides PCIe cable connection from the I/O enclosure to the High Performance Flash Enclosure Gen3 enclosure pairs.

Host adapters

An I/O enclosure can support up to 16 host ports.

Each of the four 16 or 32 Gbps Fibre Channel ports on a PCIe-attached host adapter can be independently configured to use SCSI/FCP or FICON/zHPF protocols. Both longwave and shortwave adapter versions that support different maximum cable lengths are available. The host-adapter ports can be directly connected to attached hosts systems or storage systems, or connected to a storage area network. SCSI/FCP ports are used for connections between storage systems. SCSI/FCP ports that are attached to a SAN can be used for both host and storage system connections.

The High Performance FICON® Extension (zHPF) protocol can be used by FICON host channels that have zHPF support. The use of zHPF protocols provides a significant reduction in channel usage. This reduction improves I/O input on a single channel and reduces the number of FICON channels that are required to support the workload.

Processor nodes

The processor nodes drive all functions in the storage system. Each node consists of a Power® server that contains POWER9+™ processors and memory.

Management console

The management console is also referred to as the Hardware Management Console (or HMC). It supports storage system hardware and firmware installation and maintenance activities.

The storage facility contains two redundant interconnected HMCs. Each HMC is a 1U high rack mounted 7063-CR2 Power Server.

The HMC connects to the customer network and provides access to functions that can be used to manage the storage system. Management functions include logical configuration, problem notification, call home for service, remote service, remote code load, and Copy Services management. You can perform management functions from the DS8000® Storage Management GUI, DS command-line interface (DS CLI), or other storage management software that supports the storage system.

Ethernet switches

The Ethernet switches provide internal communication between the management consoles, processor nodes, and iPDU pairs. Two redundant Ethernet switches are provided.

Power

Intelligent PDUs (iPDUs) supply power to the storage system, and processor node backup power modules (BPMs) provide power to the non-volatile dual inline memory module (NVDIMM) when electrical power is removed.

iPDUs provide several benefits.

- IBM Active Energy Manager (AEM) support
- IBM Power Line Disturbance (PLD) compliance up to 20 milliseconds
- Individual outlet monitoring and control
- Firmware updates
- Circuit breaker protection
- Worldwide voltage and power connector support

To optimize data security, reliability, and recovery time, BPMs retain NVDIMM data when electrical power is removed from either an unexpected power loss or normal system shutdown.

Functional overview

The following list provides an overview of some of the features that are associated with the DS8000 10th generation.

Note: Some storage system functions are not available or are not supported in all environments. See the IBM System Storage Interoperation Center (SSIC) website (www-03.ibm.com/systems/support/storage/ssic/interoperability.was) for the most current information on supported hosts, operating systems, adapters, and switches.

Nondisruptive and disruptive activities

DS8000 10th generation supports hardware redundancy. It is designed to support nondisruptive changes: hardware upgrades, repair, and licensed function upgrades. In addition, logical configuration changes can be made nondisruptively. For example:

- The flexibility and modularity means that an expansion frame can be added and usable storage capacity can be increased within a frame without disrupting your applications.
- An increase in license scope is nondisruptive and takes effect immediately. A decrease in license scope is also nondisruptive but does not take effect until the next IML.
- Easy Tier helps keep performance optimized by periodically redistributing data to help eliminate drive hot spots that can degrade performance. This function helps balance I/O activity across the drives in an existing drive tier. It can also automatically redistribute some data to new empty drives added to a tier to help improve performance by taking advantage of the new resources. Easy Tier does this I/O activity rebalancing automatically without disrupting access to your data.

The following examples include activities that are disruptive:

- The installation of an earthquake resistance kit on a raised or nonraised floor.
- The removal of an expansion frame from the base frame.

Energy reporting

You can use the DS8000 10th generation to display the following energy measurements through the DS CLI:

- Average inlet temperature in Celsius
- Total data transfer rate in MB/s
- Timestamp of the last update for values

The derived values are averaged over a 5-minute period. For more information about energy-related commands, see the commands reference.

You can also query power usage and data usage with the **shows** command. For more information, see the **shows** description in the *Command-Line Interface User's Guide*.

National Institute of Standards and Technology (NIST) SP 800-131A security enablement

NIST SP 800-131A requires the use of cryptographic algorithms that have security strengths of 112 bits to provide data security and data integrity for secure data that is created in the cryptoperiod starting in 2014. The DS8000 10th generation is enabled for NIST SP 800-131A. Conformance with NIST SP 800-131A depends on the use of appropriate prerequisite management software versions and appropriate configuration of the DS8000 10th generation and other network-related entities.

Storage pool striping (rotate capacity)

Storage pool striping is supported on the DS8000 series, providing improved performance. The storage pool striping function stripes new volumes across all arrays in a pool. The striped volume layout reduces workload skew in the system without requiring manual tuning by a storage administrator. This approach can increase performance with minimal operator effort. With storage pool striping support, the system automatically performs close to highest efficiency, which requires little or no administration. The effectiveness of performance management tools is also enhanced because imbalances tend to occur as isolated problems. When performance administration is required, it is applied more precisely.

You can configure and manage storage pool striping by using the DS8000 Storage Management GUI, DS CLI, and DS Open API. The rotate capacity allocation method (also referred to as rotate volumes) is an alternative allocation method that tends to prefer volumes that are allocated to a single managed array, and is not recommended. The rotate extents option (storage pool striping) is designed to provide the best performance by striping volumes across arrays in the pool. Existing volumes can be reconfigured nondisruptively by using manual volume migration and volume rebalance.

The storage pool striping function is provided with the DS8000 series at no additional charge.

Performance statistics

You can use usage statistics to monitor your I/O activity. For example, you can monitor how busy the I/O ports are and use that data to help manage your SAN. For more information, see documentation about performance monitoring in the DS8000 Storage Management GUI.

Sign-on support that uses Lightweight Directory Access Protocol (LDAP)

The DS8000 system provides support for both unified sign-on functions (available through the DS8000 Storage Management GUI), and the ability to specify an existing Lightweight Directory Access Protocol (LDAP) server. The LDAP server can have existing users and user groups that can be used for authentication on the DS8000 system.

Note: Other supported user directory servers include IBM Directory Server and Microsoft Active Directory.

Easy Tier

Easy Tier is designed to determine the appropriate tier of storage based on data access requirements and then automatically and nondisruptively move data, at the subvolume or sub-LUN level, to the appropriate tier on the DS8000 system. Easy Tier is an optional feature that offers enhanced capabilities through features such as auto-rebalancing, hot spot management, rank depopulation, and manual volume migration.

Easy Tier enables the DS8000 10th generation system to automatically balance I/O access to drives to avoid hot spots on arrays. Easy Tier can place data in the storage tier that best suits the access frequency of the data. Highly accessed data can be moved nondisruptively to a higher tier, and likewise cooler data is moved to a lower tier.

Easy Tier also can benefit homogeneous drive pools because it can move data away from over-utilized arrays to under-utilized arrays to eliminate hot spots and peaks in drive response times.

z-synergy

The DS8000 10th generation storage system can work in cooperation with IBM Z hosts to provide the following performance enhancement functions.

- Extended Address Volumes
- High Performance FICON for IBM Z
- Parallel Access Volumes and HyperPAV (also referred to as aliases)
- Quick initialization for IBM Z
- ZHyperLink technology that speeds up transaction processing and improves active log throughput
- IBM Fibre Channel Endpoint Security

zHyperLink read and write function

zHyperLink is a short distance, mainframe-attached link that provides up to 10 times lower latency than high-performance FICON. zHyperLink speeds Db2 for z/OS transaction processing and improves active log throughput. zHyperLink technology delivers low latency when traditional SAN-attached storage systems are used with its complementary short-distance link technology.

Low latencies are provided for read and write operations for storage systems within the 150-meter distance requirement by using a point-to-point link from the IBM Z to the storage system I/O bay. Low I/O latencies deliver value through improved workload-elapsed times and faster transactional response times, and contribute to lower scaling costs. This storage system implementation of zHyperLink I/O delivers service times fast enough to enable a synchronous I/O model in high-performance IBM Z servers.

Copy Services

The DS8000 10th generation storage system supports a wide variety of Copy Service functions, including Remote Mirror, Remote Copy, and Point-in-Time functions. The following includes key Copy Service functions:

- FlashCopy
- Remote Pair FlashCopy (Preserve Mirror)
- Safeguarded Copy
- Remote Mirror and Copy:
 - Metro Mirror
 - Global Copy
 - Global Mirror
 - Metro/Global Mirror
 - Multi-Target PPRC
 - z/OS Global Mirror
 - z/OS Metro/Global Mirror

Multitenancy support (resource groups)

Resource groups provide additional policy-based limitations. Resource groups, together with the inherent volume addressing limitations, support secure partitioning of Copy Services resources between user-defined partitions. The process of specifying the appropriate limitations is performed by an administrator using resource groups functions. DS CLI support is available for resource groups functions.

Multitenancy can be supported in certain environments without the use of resource groups, if the following constraints are met:

- Either Copy Services functions are disabled on all DS8000 systems that share the same SAN (local and remote sites) or the landlord configures the operating system environment on all hosts (or host LPARs) attached to a SAN, which has one or more DS8000 systems, so that no tenant can issue Copy Services commands.
- The z/OS® Distribute Data backup feature is disabled on all DS8000 systems in the environment (local and remote sites).
- Thin provisioned volumes (ESE) are not used on any DS8000 systems in the environment (local and remote sites).
- On zSeries systems there is only one tenant running in an LPAR, and the volume access is controlled so that a CKD base volume or alias volume is only accessible by a single tenant's LPAR or LPARs.

Restriction of hazardous substances (RoHS)

The DS8000 10th generation system meets RoHS requirements. It conforms to the following EC directives:

- Directive 2011/65/EU of the European Parliament and of the Council of 8 June 2011 on the restriction of the use of certain hazardous substances in electrical and electronic equipment. It has been demonstrated that the requirements specified in Article 4 have been met.
- EN 50581:2012 technical documentation for the assessment of electrical and electronic products with respect to the restriction of hazardous substances.

Updating code levels

Update the code levels on your DS8000 storage system with a concurrent code load. Concurrent code load is a nondisruptive procedure to install firmware or software on a storage system. The set of code loads that can be installed within a given storage system are model-dependent.

For a list of recommended code levels, go to the [DS8000 Code Recommendation website](#).

There are three options for concurrent code load: on-site code load performed by an IBM® service support representative (SSR), remote code load (RCL) performed remotely by the RCL team, and customer code load performed by the customer. Support is determined at the point of sale for the appropriate features.

To initiate the RCL process, go to the [RCL booking tool](#). After the RCL begins, there is little to no interaction until the process completes. IBM is notified regarding the success or failure of the code load through a call home notification. If a failure notice is received, an SSR might be required on site to initiate the corrective action.

The customer code load process is to initiate the update of current code level of DS8000 storage system with a concurrent code level that is downloaded from FixCentral by the customer without going through IBM support.

Logical configuration

You can use either the DS8000 Storage Management GUI or the DS CLI to configure storage. Although the end result of storage configuration is similar, each interface has specific terminology, concepts and procedures.

Note: LSS is synonymous with logical control unit (LCU) and subsystem identification (SSID).

Logical configuration with DS8000 Storage Management GUI

Before you configure your storage system, it is important to understand the storage concepts and sequence of system configuration.

[Figure 2 on page 10](#) illustrates the concepts of configuration.

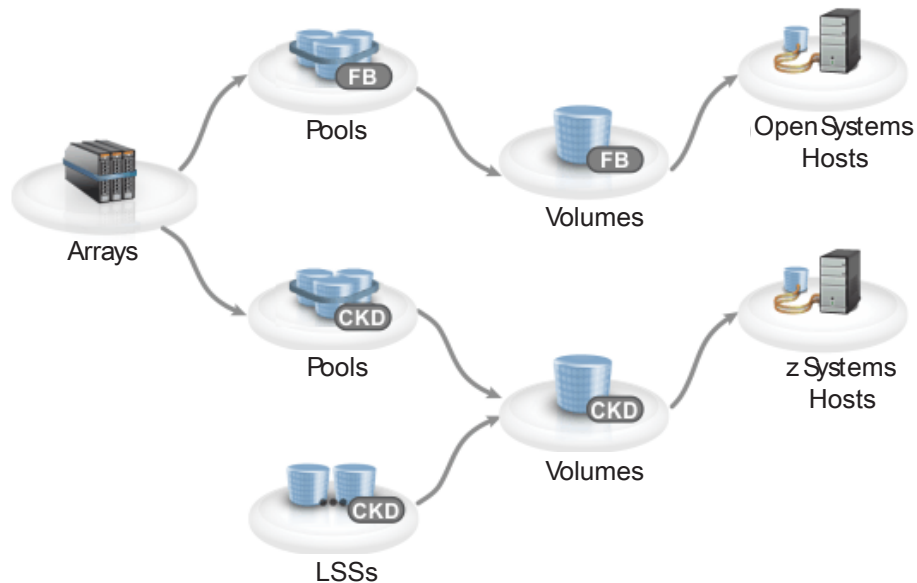

Figure 2. Logical configuration sequence

The following concepts are used in storage configuration.

Arrays

An array, also referred to as a managed array, is a group of storage devices that provides capacity for a pool. An array generally consists of 8 drives that are managed as a Redundant Array of Independent Disks (RAID).

Pools

A storage pool is a collection of storage that identifies a set of storage resources. These resources provide the capacity and management requirements for arrays and volumes that have the same storage type, either fixed block (FB) or count key data (CKD).

Volumes

A volume is a fixed amount of storage on a storage device.

LSS

The logical subsystem (LSS) that enables one or more host I/O interfaces to access a set of devices.

Hosts

A host is the computer system that interacts with the storage system. Hosts defined on the storage system are configured with a user-designated host type that enables the storage system to recognize and interact with the host. Only hosts that are mapped to volumes can access those volumes.

Logical configuration of the storage system begins with managed arrays. When you create storage pools, you assign the arrays to pools and then create volumes in the pools. FB volumes are connected through host ports to an open systems host. CKD volumes require that logical subsystems (LSSs) be created as well so that they can be accessed by an IBM Z host.

Pools must be created in pairs to balance the storage workload. Each pool in the pool pair is controlled by a processor node (either Node 0 or Node 1). Balancing the workload helps to prevent one node from doing most of the work and results in more efficient I/O processing, which can improve overall system performance. Both pools in the pair must be formatted for the same storage type, either FB or CKD storage. You can create multiple pool pairs to isolate workloads.

When you create a pair of pools, you can choose to automatically assign all available arrays to the pools, or assign them manually afterward. If the arrays are assigned automatically, the system balances them across both pools so that the workload is distributed evenly across both nodes. Automatic assignment also ensures that spares and device adapter (DA) pairs are distributed equally between the pools.

If you are connecting to a IBM Z host, you must create a logical subsystem (LSS) before you can create CKD volumes.

You can create a set of volumes that share characteristics, such as capacity and storage type, in a pool pair. The system automatically balances the volumes between both pools. If the pools are managed by Easy Tier, the capacity in the volumes is automatically distributed among the arrays. If the pools are not managed by Easy Tier, you can choose to use the rotate capacity allocation method, which stripes capacity across the arrays.

If the volumes are connecting to a IBM Z host, the next steps of the configuration process are completed on the host.

If the volumes are connecting to an open systems host, map the volumes to the host, add host ports to the host, and then map the ports to the I/O ports on the storage system.

FB volumes can only accept I/O from the host ports of hosts that are mapped to the volumes. Host ports are zoned to communicate only with certain I/O ports on the storage system. Zoning is configured either within the storage system by using I/O port masking, or on the switch. Zoning ensures that the workload is spread properly over I/O ports and that certain workloads are isolated from one another, so that they do not interfere with each other.

The workload enters the storage system through I/O ports, which are on the host adapters. The workload is then fed into the processor nodes, where it can be cached for faster read/write access. If the workload is not cached, it is stored on the arrays in the storage enclosures.

Logical configuration with DS CLI

Before you configure your storage system with the DS CLI, it is important to understand the terminology for storage concepts and the storage hierarchy.

In the storage hierarchy, you begin with a physical disk. Logical groupings of eight disks form an array site. Logical groupings of one array site form an array. After you define your array storage type as CKD or fixed block, you can create a rank. A rank is divided into a number of fixed-size extents. If you work with an open-systems host, a large extent is 1 GiB, and a small extent is 16 MiB. If you work in an IBM Z environment, a large extent is the size of an IBM 3390 Mod 1 disk drive (1113 cylinders), and a small extent is 21 cylinders.

After you create ranks, your physical storage can be considered virtualized. Virtualization dissociates your physical storage configuration from your logical configuration, so that volume sizes are no longer constrained by the physical size of your arrays.

The available space on each rank is divided into extents. The extents are the building blocks of the logical volumes. An extent is striped across all disks of an array.

Extents of the same storage type are grouped to form an extent pool. Multiple extent pools can create storage classes that provide greater flexibility in storage allocation through a combination of RAID types, DDM size, DDM speed, and DDM technology. This configuration allows a differentiation of logical volumes by assigning them to the appropriate extent pool for the needed characteristics. Different extent sizes for the same device type (for example, count-key-data or fixed block) can be supported on the same storage unit. The different extent types must be in different extent pools.

A logical volume is composed of one or more extents. A volume group specifies a set of logical volumes. Identify different volume groups for different uses or functions (for example, SCSI target, remote mirror and copy secondary volumes, FlashCopy® targets, and Copy Services). Access to the set of logical volumes that are identified by the volume group can be controlled. Volume groups map hosts to volumes. [Figure 3 on page 13](#) shows a graphic representation of the logical configuration sequence.

When volumes are created, you must initialize logical tracks from the host before the host is allowed read and write access to the logical tracks on the volumes. The Quick Initialization feature for open system on FB ESE volumes allows quicker access to logical volumes. The volumes include host volumes and source volumes that can be used Copy Services relationships, such as FlashCopy or Remote Mirror and Copy relationships. This process dynamically initializes logical volumes when they are created or expanded, allowing them to be configured and placed online more quickly.

You can specify LUN ID numbers through the graphical user interface (GUI) for volumes in a map-type volume group. You can create a new volume group, add volumes to an existing volume group, or add a volume group to a new or existing host. Previously, gaps or holes in LUN ID numbers might result in a "map error" status. The **Status** field is eliminated from the volume groups main page in the GUI and the volume groups accessed table on the **Manage Host Connections** page. You can also assign host connection nicknames and host port nicknames. Host connection nicknames can be up to 28 characters, which is expanded from the previous maximum of 12. Host port nicknames can be 32 characters, which are expanded from the previous maximum of 16.

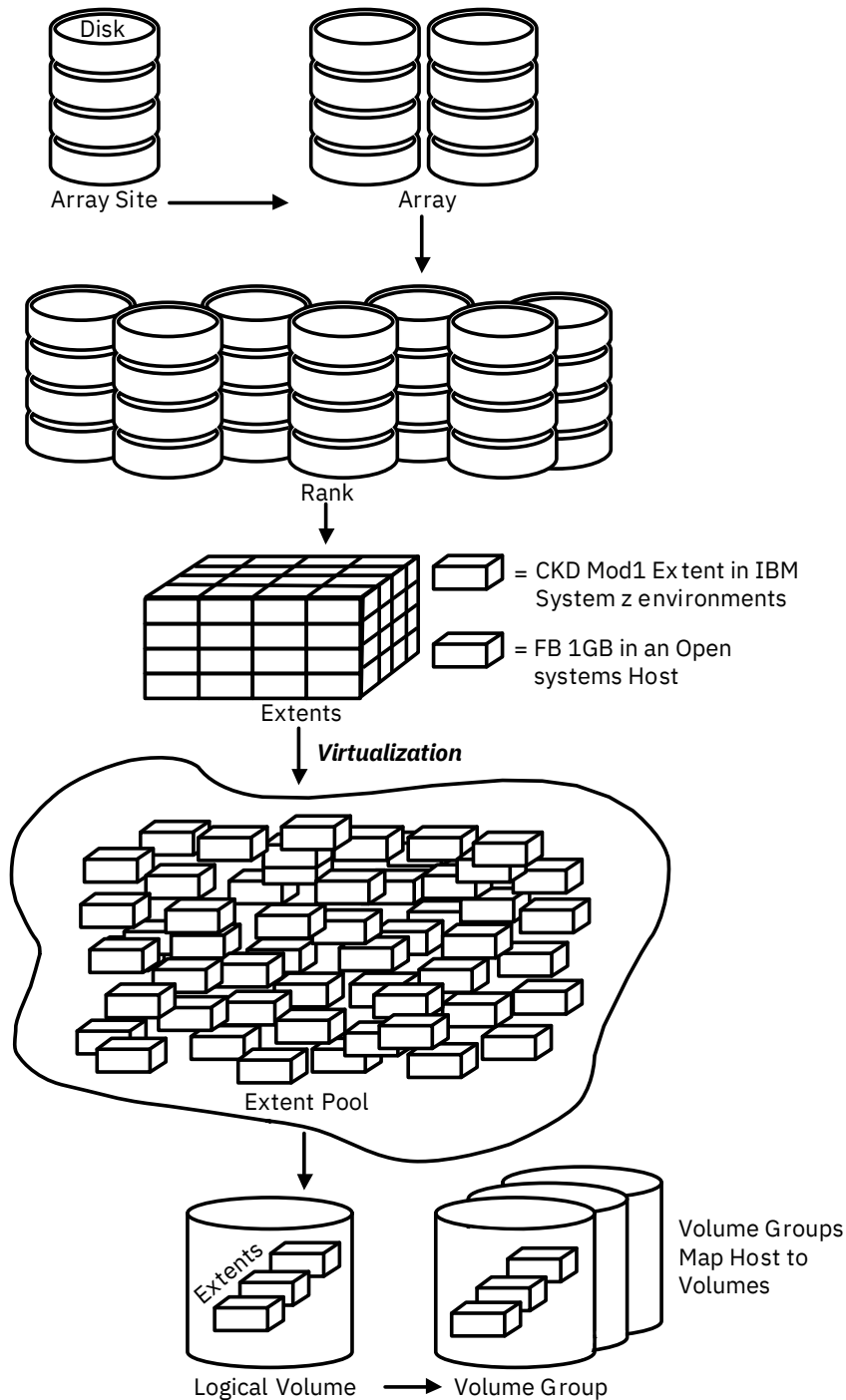

Figure 3. Logical configuration sequence

RAID implementation

RAID implementation improves data storage reliability and performance.

Redundant array of independent disks (RAID) is a method of configuring multiple drives in a storage subsystem for high availability and high performance. The collection of two or more drives presents the image of a single drive to the system. If a single device failure occurs, data can be read or regenerated from the other drives in the array.

RAID implementation provides fault-tolerant data storage by storing the data in different places on multiple drives. By placing data on multiple drives, I/O operations can overlap in a balanced way to improve the basic reliability and performance of the attached storage devices.

Usable capacity for the storage system can be configured as RAID 6, or RAID 10. RAID 6 can offer excellent performance for some applications, while RAID 10 can offer better performance for selected applications, in particular, high random, write content applications in the open systems environment.

RAID 6 is the recommended and default RAID type for all drives over 1 TB. RAID 6 and RAID 10 are the only supported RAID types for 3.84 TB Flash Tier 1 drives and 1.92 TB, 7.68 TB, and 15.36 TB Flash Tier 2 drives.

RAID 6 overview

RAID 6 is a method of increasing the data protection of arrays with volume data spread across multiple disk drives.

RAID 6 increases data protection by adding an extra layer of parity over the RAID 5 implementation. By adding this protection, RAID 6 can restore data from an array with up to two failed drives. The calculation and storage of extra parity slightly reduces the capacity and performance compared to a RAID 5 array.

Note: RAID 6 is the recommended and default RAID type for all drives over 1 TB. RAID 6 and RAID 10 are the only supported RAID types for 3.84 TB Flash Tier 1 drives and 1.92 TB, 7.68 TB, and 15.36 TB Flash Tier 2 drives.

RAID 10 overview

RAID 10 provides high availability by combining features of RAID 0 and RAID 1.

RAID 0 increases performance by striping volume data across multiple disk drives. RAID 1 provides disk mirroring, which duplicates data between two disk drives. By combining the features of RAID 0 and RAID 1, RAID 10 provides a second optimization for fault tolerance.

RAID 10 implementation provides data mirroring from one disk drive to another disk drive. RAID 10 stripes data across half of the disk drives in the RAID 10 configuration. The other half of the array mirrors the first set of disk drives. Access to data is preserved if one disk in each mirrored pair remains available. In some cases, RAID 10 offers faster data reads and writes than RAID 6 because it is not required to manage parity. However, with half of the disk drives in the group used for data and the other half used to mirror that data, RAID 10 arrays have less capacity than RAID 6 arrays.

Note: RAID 6 is the recommended and default RAID type for all drives over 1 TB. RAID 6 and RAID 10 are the only supported RAID types for 3.84 TB Flash Tier 1 drives and 1.92 TB, 7.68 TB, and 15.36 TB Flash Tier 2 drives.

Logical subsystems

To facilitate configuration of a storage system, volumes are partitioned into groups of volumes. Each group is referred to as a logical subsystem (LSS).

As part of the storage configuration process, you can configure the maximum number of LSSs that you plan to use. The storage system can contain up to 255 LSSs and each LSS can be connected to 16 other LSSs using a logical path. An LSS is a group of up to 256 volumes that have the same storage type, either count key data (CKD) for IBM Z hosts or fixed block (FB) for open systems hosts.

An LSS is uniquely identified within the storage system by an identifier that consists of two hex characters (0-9 or uppercase A-F) for which the volumes are associated. A fully qualified LSS is designated using the storage system identifier and the LSS identifier, such as IBM.2107-921-12FA123/1E. The LSS identifiers are important for Copy Services operations. For example, for FlashCopy operations, you specify the LSS identifier when choosing source and target volumes because the volumes can span LSSs in a storage system.

The storage system has a 64K volume address space that is partitioned into 255 LSSs, where each LSS contains 256 logical volume numbers. The 255 LSS units are assigned to one of 16 address groups, where each address group contains 16 LSSs, or 4K volume addresses.

Storage system functions, including some that are associated with FB volumes, might have dependencies on LSS partitions. For example:

- The LSS partitions and their associated volume numbers must identify volumes that are specified for storage system Copy Services operations.
- To establish Remote Mirror and Copy pairs, a logical path must be established between the associated LSS pair.
- FlashCopy pairs must reside within the same storage system.

If you increase storage system capacity, you can increase the number of LSSs that you have defined. This modification to increase the maximum is a nonconcurrent action. If you might need capacity increases in the future, leave the number of LSSs set to the maximum of 255.

Note: If you reduce the CKD LSS limit to zero for IBM Z hosts, the storage system does not process Remote Mirror and Copy functions. The FB LSS limit must be no lower than eight to support Remote Mirror and Copy functions for open-systems hosts.

Allocation methods

Allocation methods (also referred to as extent allocation methods) determine the means by which provisioned capacity is allocated within a pool.

All extents of the ranks that are assigned to an extent pool are independently available for allocation to logical volumes. The extents for a LUN or volume are logically ordered, but they do not have to come from one rank and the extents do not have to be contiguous on a rank. This construction method of using fixed extents to form a logical volume in the storage system allows flexibility in the management of the logical volumes. You can delete volumes, resize volumes, and reuse the extents of those volumes to create other volumes, different sizes. One logical volume can be deleted without affecting the other logical volumes that are defined on the same extent pool.

Because the extents are cleaned after you delete a volume, it can take some time until these extents are available for reallocation. The reformatting of the extents is a background process.

There are three allocation methods that are used by the storage system: rotate capacity (also referred to as storage pool striping), rotate volumes, and managed.

Rotate capacity allocation method

The default allocation method is rotate capacity, which is also referred to as storage pool striping. The rotate capacity allocation method is designed to provide the best performance by striping volume extents across arrays in a pool. The storage system keeps a sequence of arrays. The first array in the list is randomly picked at each power-on of the storage subsystem. The storage system tracks the array in which the last allocation started. The allocation of a first extent for the next volume starts from the next array in that sequence. The next extent for that volume is taken from the next rank in sequence, and so on. The system rotates the extents across the arrays.

If you migrate a volume with a different allocation method to a pool that has the rotate capacity allocation method, then the volume is reallocated. If you add arrays to a pool, the rotate capacity allocation method reallocates the volumes by spreading them across both existing and new arrays.

You can configure and manage this allocation method by using the DS8000 Storage Management GUI and DS CLI.

Rotate volumes allocation method

Volume extents can be allocated sequentially. In this case, all extents are taken from the same array until there are enough extents for the requested volume size or the array is full, in which case the allocation continues with the next array in the pool.

If more than one volume is created in one operation, the allocation for each volume starts in another array. You might want to consider this allocation method when you prefer to manage performance manually. The workload of one volume is allocated to one array. This method makes the identification of performance bottlenecks easier; however, by putting all the volume data onto just one array, you might introduce a bottleneck, depending on your actual workload.

Managed allocation method

When a volume is managed by Easy Tier, the allocation method of the volume is referred to as managed. Easy Tier allocates the capacity in ways that might differ from both the rotate capacity and rotate volume allocation methods.

Management interfaces

You can use various IBM storage management interfaces to manage your storage system.

These interfaces include DS8000 Storage Management GUI, DS Command-Line Interface (DS CLI), the DS Open Application Programming Interface, DS8000 RESTful API, IBM Spectrum Control and IBM Copy Services Manager.

DS8000 Storage Management GUI

Use the DS8000 Storage Management GUI to configure and manage storage, and to monitor performance and Copy Services functions.

DS8000 Storage Management GUI is a web-based GUI that is installed on the Hardware Management Console (HMC). You can access the DS8000 Storage Management GUI from any network-attached system by using a supported web browser. For a list of supported browsers, see [“DS8000 Storage Management GUI web browser support and configuration”](#) on page 18.

You can access the DS8000 Storage Management GUI from a browser by using the following web address, where *HMC_IP* is the IP address or host name of the HMC.

```
https://HMC_IP
```

If the DS8000 Storage Management GUI does not display as anticipated, clear the cache for your browser, and try to log in again.

Notes:

- If the storage system is configured for NIST SP 800-131A security conformance, a version of Java that is NIST SP 800-131A compliant must be installed on all systems that run the DS8000 Storage Management GUI. For more information about security requirements, see [Planning for security](#).
- User names and passwords are encrypted for HTTPS protocol. You cannot access the DS8000 Storage Management GUI over the non-secure HTTP protocol (port 8451).

DS command-line interface

The IBM® DS command-line interface (DS CLI) can be used to create, delete, modify, and view Copy Services functions and the logical configuration of a storage system. These tasks can be performed either interactively, in batch processes (operating system shell scripts), or in DS CLI script files. A DS CLI script file is a text file that contains one or more DS CLI commands and can be issued as a single command. DS CLI can be used to manage logical configuration, Copy Services configuration, and other functions for a storage system, including managing security settings, querying point-in-time performance information or status of physical resources, and exporting audit logs.

Note: Java 1.8 must be installed on systems that run the DS CLI.

The DS CLI provides a full-function set of commands to manage logical configurations and Copy Services configurations. The DS CLI is available in the DS8000® Storage Management GUI. The DS CLI client can also be installed on and is supported in many different environments, including the following platforms:

- – AIX® 7.1, 7.2, 7.3
 - Linux®, Red Hat Enterprise Linux [RHEL] 7
 - Linux, SUSE Linux, Enterprise Server (SLES) 12
 - VMware ESX 6 Console
 - IBM i 7.2

- Oracle Solaris 11
- Microsoft Windows 8, 8.1, 10, 11

Note: If the storage system is configured for NIST SP 800-131A security conformance, a version of Java that is NIST SP 800-131A compliant must be installed on all systems that run DS CLI client. For more information about security requirements, see documentation about configuring your environment for NIST SP 800-131A compliance in Planning for NIST SP 800-131A security conformance).

RESTful API

The RESTful API is an application on your storage system HMC for initiating simple storage operations through the Web.

The RESTful (Representational State Transfer) API is a platform-independent means by which to initiate create, read, update, and delete operations in the storage system and supporting storage devices. These operations are initiated with the HTTP commands: **POST**, **GET**, **PUT**, and **DELETE**.

The RESTful API is intended for development, testing, and debugging of the client management infrastructures in your storage system. You can use the RESTful API with a CURL command or through standard Web browsers. For instance, you can use the storage system with the RESTClient add-on.

IBM Spectrum Control

IBM Spectrum Control is an integrated software solution that can help you improve and centralize the management of your storage environment through the integration of products. With IBM Spectrum Control, it is possible to manage multiple DS8000 systems from a single point of control.

Note: IBM Spectrum Control is not required for the operation of a storage system. However, it is recommended. IBM Spectrum Control can be ordered and installed as a software product on various servers and operating systems. When you install IBM Spectrum Control, ensure that the selected version supports the current system functions. Optionally, you can order a server on which IBM Spectrum Control is preinstalled.

IBM Spectrum Control simplifies storage management by providing the following benefits:

- Centralizing the management of heterogeneous storage network resources with IBM storage management software
- Providing greater synergy between storage management software and IBM storage devices
- Reducing the number of servers that are required to manage your software infrastructure
- Migrating from basic device management to storage management applications that provide higher-level functions

For more information, see [IBM Spectrum Control online product documentation in IBM Documentation \(www.ibm.com/docs/spectrum-control\)](http://www.ibm.com/docs/spectrum-control).

IBM Copy Services Manager

IBM Copy Services Manager controls Copy Services in storage environments. Copy Services are features that are used by storage systems, such as DS8000, to configure, manage, and monitor data-copy functions.

IBM Copy Services Manager provides both a graphical interface and command line that you can use for configuring and managing Copy Services functions across storage units. Copy Services include the point-in-time function – IBM FlashCopy and Safeguarded Copy, and the remote mirror and copy functions – Metro Mirror, Global Mirror, and Metro Global Mirror. Copy Services Manager can automate the administration and configuration of these services; and monitor and manage copy sessions.

You can use Copy Services Manager to complete the following data replication tasks and help reduce the downtime of critical applications:

- Plan for replication when you are provisioning storage

- Keep data on multiple related volumes consistent across storage systems for a planned or unplanned outage
- Monitor and track replication operations
- Automate the mapping of source volumes to target volumes
- Provide High Availability with HyperSwap

Before you use Copy Services Manager on the HMC, see <https://ibm.biz/BdqfbJ> for more information.

For more information on Copy Services Manager, see [Copy Services Manager online documentation](#) and select the latest version of the product. The "What's new" topic provides details on the features added for each version of Copy Services Manager that can be used by DS8000, including HyperSwap for multi-target sessions, and incremental FlashCopy support.

DS8000 Storage Management GUI web browser support and configuration

To access the DS8000 Storage Management GUI, you must ensure that your web browser is supported and has the appropriate settings enabled.

The DS8000 Storage Management GUI supports the following web browsers:

<i>Table 10. Supported web browsers</i>	
DS8000 series version	Supported browsers
10.0	Mozilla Firefox 68 Microsoft Internet Explorer 11 Note: Microsoft Internet Explorer 11 supports TLS 1.2, but it does not support TLS 1.3. Microsoft Edge 44 Google Chrome 76

IBM supports higher versions of the browsers as long as the vendors do not remove or disable functionality that the product relies upon. For browser levels higher than the versions that are certified with the product, customer support accepts usage-related and defect-related service requests. As with operating system and virtualization environments, if the support center cannot re-create the issue in the our lab, we might ask the client to re-create the problem on a certified browser version to determine whether a product defect exists. Defects are not accepted for cosmetic differences between browsers or browser versions that do not affect the functional behavior of the product. If a problem is identified in the product, defects are accepted. If a problem is identified with the browser, IBM might investigate potential solutions or workaround that the client can implement until a permanent solution becomes available.

Enabling TLS 1.2 and TLS 1.3 support

If the security requirements for your storage system require conformance with NIST SP 800-131A, enable transport layer security (TLS) 1.2 or 1.3 on web browsers that use TLS to access the DS8000 Storage Management GUI. See your web browser documentation for instructions on enabling TLS 1.2 or 1.3. For Internet Explorer, complete the following steps to enable TLS 1.2.

1. On the **Tools** menu, click **Internet Options**.
2. On the **Advanced** tab, under **Settings**, select **Use TLS 1.2**.

Note:

- Firefox, Release 24 and later, supports TLS 1.2. However, you must configure Firefox to enable TLS 1.2 support.

- Microsoft Internet Explorer 11 does not support TLS 1.3.

For more information about security requirements, see the IBM DS8000 series online product documentation for security best practices.

Selecting browser security settings

You must select the appropriate web browser security settings to access the DS8000 Storage Management GUI. In Internet Explorer, use the following steps.

1. On the **Tools** menu, click **Internet Options**.
2. On the **Security** tab, select **Internet** and click **Custom level**.
3. Scroll to **Miscellaneous**, and select **Allow META REFRESH**.
4. Scroll to **Scripting**, and select **Active scripting**.

Configuring Internet Explorer to access the DS8000 Storage Management GUI

If DS8000 Storage Management GUI is accessed through IBM Spectrum Control with Internet Explorer, complete the following steps to properly configure the web browser.

1. Disable the **Pop-up Blocker**.

Note: If a message indicates that content is blocked without a signed by a valid security certificate, click the **Information Bar** at the top and select **Show blocked content**.

2. Add the IP address of the DS8000 Hardware Management Console (HMC) to the Internet Explorer list of trusted sites.

For more information, see your browser documentation.

Chapter 2. Hardware features

Use this information to assist you with planning, ordering, and managing your storage system.

The following table lists feature codes that are used to order hardware features for your system.

Feature code	Feature	Description
0020	DoD indicator	Provides a special label required for Department of Defense orders.
0021	JEMT indicator	Indicates an IBM internal order for machine under the Joint Engineering Manufacturing Test (JEMT) program. It is for administrative purposes only.
0262	1.6TB 2.5 flash encl ind	Notifies manufacturing on the number of high-performance flash enclosures used to support 1.6 TB flash drive sets. This feature is used together with the Flash card sets custom placement indicator feature. It is for administrative purposes only. User needs to indicate how many high-performance flash enclosures are required based on the type of flash drive selected.
0264	1.92 TB 2.5 flash encl ind	Notifies manufacturing on the number of high-performance flash enclosures used to support 1.92 TB flash drive sets. This feature is used together with the Flash card sets custom placement indicator feature. It is for administrative purposes only. User needs to indicate how many high-performance flash enclosures are required based on the type of flash drive selected.
0265	3.8 TB 2.5 flash encl ind	Notifies manufacturing on the number of high-performance flash enclosures used to support 3.84 TB flash drive sets. This feature is used together with the Flash card sets custom placement indicator feature. It is for administrative purposes only. User needs to indicate how many high-performance flash enclosures are required based on the type of flash drive selected.
0266	7.68 TB 2.5 flash encl ind	Notifies manufacturing on the number of high-performance flash enclosures used to support 7.68 TB flash drive sets. This feature is used together with the Flash card sets custom placement indicator feature. It is for administrative purposes only. User needs to indicate how many high-performance flash enclosures are required based on the type of flash drive selected.

Table 11. Feature codes for hardware features (continued)

Feature code	Feature	Description
0400	BSMI Certificate - Taiwan	The Taiwanese government agency imposes compliance requirements on products sold within Taiwan. This feature facilitates the production of specific BSMI documents for shipments to Taiwan, thus fulfilling these regulatory standards.
0403	Encryption not capable	Disables the encryption capabilities of the unit, making it unable to enable encryption in the field. The government agency for the People's Republic of China and Russia have encryption compliance requirements on products sold into China and Russia. This feature must be included in any order shipping to China and Russia to guarantee the non-encryption certification key is applied to comply with those requirements.
0404	TDCPP free indicator	Acts as a safety value to insure any assembly/PNs being shipped is TDCPP free. It is only required if the unit is going to be shipped to a jurisdiction that requires the removal of TDCPP from components.
0785	Safe Guarded Copy Indicator	Indicates that the product uses Safe Guard Copy (SGC) functionality.
0796	5.1 TB to 10 TB capacity	Indicates the total raw capacity of the system at initial order is between 5.1 and 10 TB and is used for administrative purposes only. To determine the total capacity, perform the following calculation: <ol style="list-style-type: none"> 1. Determine the total number of #16xx flash card features on the order for each flash card capacity (each quantity represents 16 cards for #16xx) 2. Multiply each total by its respective disk drive capacity 3. Add together all the resulting values
0797	10.1 TB to 25 TB capacity	Indicates the total raw capacity of the system at initial order is between 10.1 and 25 TB and is used for administrative purposes only. To determine the total capacity, perform the following calculation: <ol style="list-style-type: none"> 1. Determine the total number of #16xx flash card features on the order for each flash card capacity (each quantity represents 16 cards for #16xx) 2. Multiply each total by its respective disk drive capacity 3. Add together all the resulting values

Table 11. Feature codes for hardware features (continued)

Feature code	Feature	Description
0798	25.1 TB to 50 TB capacity	<p>Indicates the total raw capacity of the system at initial order is between 25.1 and 50 TB and is used for administrative purposes only. To determine the total capacity, perform the following calculation:</p> <ol style="list-style-type: none"> 1. Determine the total number of #16xx flash card features on the order for each flash card capacity (each quantity represents 16 cards for #16xx) 2. Multiply each total by its respective disk drive capacity 3. Add together all the resulting values
0799	50.1 TB to 75 TB capacity	<p>Indicates the total raw capacity of the system at initial order is between 50.1 and 75 TB and is used for administrative purposes only. To determine the total capacity, perform the following calculation:</p> <ol style="list-style-type: none"> 1. Determine the total number of #16xx flash card features on the order for each flash card capacity (each quantity represents 16 cards for #16xx) 2. Multiply each total by its respective disk drive capacity 3. Add together all the resulting values
0801	75.1 TB to 100.0 TB capacity	<p>Indicates the total raw capacity of the system at initial order is between 75.1 and 100 TB and is used for administrative purposes only. To determine the total capacity, perform the following calculation:</p> <ol style="list-style-type: none"> 1. Determine the total number of #16xx flash card features on the order for each flash card capacity (each quantity represents 16 cards for #16xx) 2. Multiply each total by its respective disk drive capacity 3. Add together all the resulting values

Table 11. Feature codes for hardware features (continued)

Feature code	Feature	Description
0803	100.1 TB to 250 TB capacity	<p>Indicates the total raw capacity of the system at initial order is between 100.1 and 250 TB and is used for administrative purposes only. To determine the total capacity, perform the following calculation:</p> <ol style="list-style-type: none"> 1. Determine the total number of #16xx flash card features on the order for each flash card capacity (each quantity represents 16 cards for #16xx) 2. Multiply each total by its respective disk drive capacity 3. Add together all the resulting values
0804	250.1 TB to 500 TB capacity	<p>Indicates the total raw capacity of the system at initial order is between 250.1 and 500 TB and is used for administrative purposes only. To determine the total capacity, perform the following calculation:</p> <ol style="list-style-type: none"> 1. Determine the total number of #16xx flash card features on the order for each flash card capacity (each quantity represents 16 cards for #16xx) 2. Multiply each total by its respective disk drive capacity 3. Add together all the resulting values
0806	500.1 TB to 1250 TB capacity	<p>Indicates the total raw capacity of the system at initial order is between 500.1 and 1250 TB and is used for administrative purposes only. To determine the total capacity, perform the following calculation:</p> <ol style="list-style-type: none"> 1. Determine the total number of #16xx flash card features on the order for each flash card capacity (each quantity represents 16 cards for #16xx) 2. Multiply each total by its respective disk drive capacity 3. Add together all the resulting values

Table 11. Feature codes for hardware features (continued)

Feature code	Feature	Description
0807	1250.1 TB to 3000 TB capacity	<p>Indicates the total raw capacity of the system at initial order is between 1250.1 and 3000 TB and is used for administrative purposes only. To determine the total capacity, perform the following calculation:</p> <ol style="list-style-type: none"> 1. Determine the total number of #16xx flash card features on the order for each flash card capacity (each quantity represents 16 cards for #16xx) 2. Multiply each total by its respective disk drive capacity 3. Add together all the resulting values
0808	3000.1 TB to 6000 TB capacity	<p>Indicates the total raw capacity of the system at initial order is between 3000.1 and 6000 TB and is used for administrative purposes only. To determine the total capacity, perform the following calculation:</p> <ol style="list-style-type: none"> 1. Determine the total number of #16xx flash card features on the order for each flash card capacity (each quantity represents 16 cards for #16xx) 2. Multiply each total by its respective disk drive capacity 3. Add together all the resulting values
0809	6000.1TB TO 12000TB CAPACITY	<p>Indicates the total raw capacity of the system at initial order is between 6000.1 and 12000 TB and is used for administrative purposes only. To determine the total capacity, perform the following calculation:</p> <ol style="list-style-type: none"> 1. Determine the total number of #16xx flash card features on the order for each flash card capacity (each quantity represents 16 cards for #16xx) 2. Multiply each total by its respective disk drive capacity 3. Add together all the resulting values
0930	IBM/Openwave Alliance	<p>Indicates the order is part of sales activities related to the strategic alliance between IBM and Openwave. Its purpose is purely administrative. This feature is applicable to both plant and MES order operations.</p>

Table 11. Feature codes for hardware features (continued)

Feature code	Feature	Description
0931	IBM System i Indicator	Indicates that the machine will operate within the IBM System i server environment. This feature serves administrative purposes only and does not impact the technical capabilities of the system.
0932	IBM System p Indicator	Indicates that the machine will operate within the IBM System p server environment. This feature serves administrative purposes only and does not impact the technical capabilities of the system.
0933	IBM System x Indicator	Indicates the IBM System Server environment in which the machine will be used is a x86 system i. It is used for administrative purposes only and do not affect the technical capabilities of the system.
0934	IBM System z Indicator	Indicates the IBM System Server environment in which the machine will be used is IBM Z. It is used for administrative purposes only and do not affect the technical capabilities of the system.
0935	IBM System z B/C indicator	None.
0936	IBM System zEnterprise Cloud indicator	Indicates the IBM System Server environment in which the machine will be used is IBM Z Cloud. It is used for administrative purposes only and do not affect the technical capabilities of the system.
0940	Linux Indicator	Indicates the unit will be attached to servers running the Linux operating system. It is for administrative purposes only and does not affect the technical capabilities of the system.
0963	IBM SAN Volume Controller indicator	Indicates the machine will be attached with an IBM SANvolume controller system. It is used for administrative purposes only and do not affect the technical capabilities of the machine.
0964	IBM/EPIC attachment indicator	Indicates that the order is part of sales activities related to the IBM/EPIC software environment. This feature is solely for administrative purposes and applies to both plant and MES order activities.

Table 11. Feature codes for hardware features (continued)

Feature code	Feature	Description
0965	VMware VAAI indicator	Indicates the machine will be used in a VMware VAAI support environment. It is for administrative purposes only and does not affect the technical capabilities of the system.
0966	OpenStack indicator	Indicates the machine will be used with OpenStack SW driver support Cloud environment. It is for administrative purposes only and does not affect the technical capabilities of the system.
0983	US TAA compliance indicator	This optional feature is for the US Government customers and customers ordering on behalf of the US Government. When used, it provides the DS8000 as a TAA compliant system. It should not be used except where bids or customers require TAA compliance and orders with this feature number will be reviewed for relevance. The maximum order quantity for this feature is one and is for initial plant order only.
1999	Hardware installation MES	Provides IBM trained personnel to perform the hardware installation.
8999	IGF transaction indicator	Designates that the unit is involved in an IGF transaction (lease or financing). It is for administrative purposes only. When a new unit is involved in an IGF transaction, this feature must be ordered as a Record Purposes Only (RPO) MES. The RPO MES order must be placed using AAS or WTAAS; it cannot be ordered using e-config. This feature is field-install only and cannot be included on the initial order.
9994	Certified Pre-Owned Indicator	Indicates an order for a refurbished machine under the terms of the Certified Pre-Owned offering. It is for administrative purposes only.
AAA0	1.6 TB 2.5-inch NVMe flash drive	Provides a set of 16 flash cards. Flash cards are installed in a high-performance flash enclosure pair. A high-performance flash enclosure pair can support up to three flash drive sets (up to 48 flash drives).
AAAA	4.8 TB 2.5-inch NVMe FlashCore Module	Provides a set of 16 flash cards. Flash cards are installed in a high-performance flash enclosure pair. A high-performance flash enclosure pair can support up to three flash drive sets (up to 48 flash drives).

Table 11. Feature codes for hardware features (continued)

Feature code	Feature	Description
AAAB	9.6 TB 2.5-inch NVMe FlashCore Module	Provides a set of 16 flash cards. Flash cards are installed in a high-performance flash enclosure pair. A high-performance flash enclosure pair can support up to three flash drive sets (up to 48 flash drives).
AAAC	19.2 TB 2.5-inch NVMe FlashCore Module	Provides a set of 16 flash cards. Flash cards are installed in a high-performance flash enclosure pair. A high-performance flash enclosure pair can support up to three flash drive sets (up to 48 flash drives).
AAB0	1.92 TB 2.5-inch NVMe flash drive	Provides a set of 16 flash cards. Flash cards are installed in a high-performance flash enclosure pair. A high-performance flash enclosure pair can support up to three flash drive sets (up to 48 flash drives).
AAB1	3.84 TB 2.5-inch NVMe flash drive	Provides a set of 16 flash cards. Flash cards are installed in a high-performance flash enclosure pair. A high-performance flash enclosure pair can support up to three flash drive sets (up to 48 flash drives).
AAB2	7.68 TB 2.5-inch NVMe flash drive	Provides a set of 16 flash cards. Flash cards are installed in a high-performance flash enclosure pair. A high-performance flash enclosure pair can support up to three flash drive sets (up to 48 flash drives).
AAC0	Flash enclosure filler set	Provides a set of 16 flash enclosure fillers. If a high-performance flash enclosure pair is populated with only one flash drive set, it must be populated with two flash enclosure filler sets. If a high-performance flash enclosure pair is populated with only 2 flash drive sets, it must be populated with one flash enclosure filler set. If a flash enclosure pair is populated with this feature, it must be removed as additional flash drive set features are added.
ACA	HPFE Gen3 Enclosure pair	Notifies Manufacturing about the number of 4U (4 EIA) flash enclosure pairs used to support flash cards. Each HPFE Gen 3 pair can be populated with one, two or three flash drive sets of the same capacity.
AAD0	HPFE Gen3 adapter card pair	Notifies Manufacturing on the number of HPFE Gen 3 adapter pairs used to support flash cards. One HPFE Gen 3 adapter pair is required for each HPFE Gen 3 Enclosure pair.

Table 11. Feature codes for hardware features (continued)

Feature code	Feature	Description
AAE0	32 Gb 4 Port SW FCP/FICON Adapter PCIe	Provides one four-port Fibre Channel/FICON host adapter. Host adapters are installed in an I/O enclosure. For higher availability, adapters should be added in pairs and in a balanced manner across the machine.
AAE1	32 Gb 4 Port LW FCP/FICON Adapter PCIe	Provides one four-port Fibre Channel/FICON host adapter. Host adapters are installed in an I/O enclosure. For higher availability, adapters should be added in pairs and in a balanced manner across the machine
AAG0	zHyperLink adapter	Provides a one port zHyperlink adapter which resides in the PCIe G4 I/O drawer of the DS8000 and supports direct connectivity to IBM Z at distances up to 150 m.
AAH0	TCT 10Gb/1Gb ethernet pair for 2U controllers_SR	Provides a pair of 2-port 10 Gbps SFP+ shortwave optical (one for each one of the central electronics complexes) to improve bandwidth for a native cloud storage tier in IBM Z environments. OM3 or OM4 Multimode 50/125 micron fiber is required.
AAJ0	TCT 10Gb/1Gb ethernet pair for 4U controllers_SR	Provides a pair of 2-port 10 Gbps SFP+ shortwave optical (one for each one of the central electronics complexes) to improve bandwidth for a native cloud storage tier in IBM Z environments. OM3 or OM4 Multimode 50/125 micron fiber is required.
AAK0	1U Keyboard/Display	Provides a 1U Keyboard/Display for the DS8000.
AAL0	20-Core per system processor option	Provides a processor card pair corresponding to the appropriate system.
AAM0	40-Core per system processor option	Provides a processor card pair corresponding to the appropriate system.
AAP0	256 GB per system cache option (20 core)	Designates the amount of processor memory installed in the machine.
AAP1	512 GB per system cache option (20 core)	Designates the amount of processor memory installed in the machine.
AAQ0	1 TB per system cache option (40 core)	Designates the amount of processor memory installed in the machine.
AAQ1	2 TB per system cache option (40 core)	Designates the amount of processor memory installed in the machine.
AAQ2	3.5 TB per system cache option (40 core)	Designates the amount of processor memory installed in the machine.

Table 11. Feature codes for hardware features (continued)

Feature code	Feature	Description
AAS0	Single Phase Power - 208V 30A NEMA L6-30P	Provides the primary source of power for the storage system with Single Phase Power - 208V 30A NEMA L6-30P power cords.
AAS1	Single Phase Power - 250V 30A/32A IEC 60309	Provides the primary source of power for the storage system with Single Phase Power - 250V 32A IEC 309 power cords.
AAS2	3 Phase Delta Power - 200V-240V 60A/63A IEC 309 (4 pin 3+PE)	Provides the primary source of power for the storage system with 3 Phase Delta Power - 200-240V (LL) 60A/63A IEC 60309 (4 pin 3+PE) power cords.
AAS3	3 Phase Wye Power - 380/220-415/240V (LL/LN) 30A/32A, IEC60309 (5 pin 3+N+PE)	Provides the primary source of power for the storage system with 3 Phase Power - 250V 32A IEC 309 (5 pin Wye) power cords.
AAS4	Single Phase Power - 250V 32A, Australia/New Zealand	Provides the primary source of power for the storage system with Single Phase Power - 250V 32A power cords.
AAS5	Single Phase Power - 250V 30A, Korea	Provides the primary source of power for the storage system with Single Phase Power - 250V 30A power cords.
AAS6	Single Phase Power - 230V 30A/32A, halogen free IEC 60309	Provides the primary source of power for the storage system with Single Phase Power - 230V 32A, halogen free IEC 390 power cords.
AAT0	I/O enclosure pair PCIe Gen4	Provides two I/O enclosures. An I/O enclosure pair supports up to two HPFE Gen3 adapter card pairs, up to two HPFE Gen3 enclosure pairs, up to four zHyperLink adapters, and up to eight host adapters.
AAU0	Rack doors	Provides a 42U high-end front door and a perforated rear door for the rack.
AAU1	Space Saver rack doors	Provides two 42U perforated doors to minimize depth, one for the front and one for the rear of the rack.
AAU2	Rack side covers	Provides two 42U high-end rack side covers. These covers are decorative and are not mandatory.
AAU3	Front & rear keyed door lock kit	Provides two sets of lock/keys (one for the front door, one for the rear door). On new machines, the cover locks are shipped separately for installation in the field.
AAV1	Top exit bracket for fibre cable	Provides the bracket to secure the Fibre cables and power line cords routed to the top of the system.

Table 11. Feature codes for hardware features (continued)

Feature code	Feature	Description
AAW0	Earthquake Kit	Provides an optional seismic kit for stabilizing the storage unit rack, so that the rack complies with IBM earthquake resistance standards. It is important for computer systems to be adequately restrained during earthquakes. This helps to prevent human injury. It also ensures that the system will be available following the earthquake by limiting potential damage to critical system components such as hard drives.
AAX0	Overhead ladder - 5 ft	One overhead ladder is recommended per data center. This feature is required for top exit installation of power cords and Fibre Channel cables.
AAX1	Kick step	One kick step is recommended per data center. This feature is required for service/installation of High Performance Flash Enclosure.
AAY0	LMC for base frame R10.0	Provides DS8000 Licensed Machine Code (LMC) corresponding to the appropriate bundle family.
AAZ0	LMC indicator for expansion frame	Provides DS8000 Licensed Machine Code (LMC) corresponding to the appropriate bundle family. It is used as an indicator on the LMC versions loaded on the base model and allows manufacturing to build the appropriate drive types for the expansion frame.
AB00	Adjacent expansion PCIE4 Cableset	Provides the cableset required to attach an expansion frame next to a base frame.
AB01	20 meter expansion PCIE4 Cableset	Provides the cableset required to attach an expansion frame up to 20 meters away from a base frame.
AB10	40 meter, 50um Fibre cable (LC/LC)	Provides one Fibre Channel cable to connect a Fibre Channel/FICON adapter port to a server or fabric component port. Each cable has a LC connector for attachment to the Fibre Channel/FICON adapter port. Cables are available with a LC connector for attachment to the server or fabric component port. The 50 micron cables are compatible with short-wave Fibre Channel/FICON host adapters.

Table 11. Feature codes for hardware features (continued)

Feature code	Feature	Description
AB11	31 meter, 50um Fibre cable (LC/SC)	Provides one Fibre Channel cable to connect a Fibre Channel/FICON adapter port to a server or fabric component port. Each cable has a LC connector for attachment to the Fibre Channel/FICON adapter port. Cables are available with a LC connector for attachment to the server or fabric component port. The 50 micron cables are compatible with short-wave Fibre Channel/FICON host adapters.
AB12	2 meter, 50um Fibre cable (LC/SC)	Provides a pigtail conversion cable that can be used to attach the Fibre Channel/FICON adapter port to a cable with a LC connector. This feature is compatible with short-wave Fibre Channel/FICON host adapters.
AB13	3 meter, 50um Fibre cable (LC/LC)	Provides one Fibre Channel cable to connect a Fibre Channel/FICON adapter port to a server or fabric component port. Each cable has a LC connector for attachment to the Fibre Channel/FICON adapter port. Cables are available with a LC connector for attachment to the server or fabric component port. The 50 micron cables are compatible with short-wave Fibre Channel/FICON host adapters.
AB20	31 meter, 9um Fibre cable (LC/LC)	Provides one Fibre Channel cable to connect a Fibre Channel/FICON adapter port to a server or fabric component port. Each cable has a LC connector for attachment to the Fibre Channel/FICON adapter port. The cables are available with a LC connector for attachment to the server or fabric component port. The 9 micron cables are compatible with long-wave Fibre Channel/FICON adapters.
AB21	31 meter, 9um Fibre cable (LC/SC)	Provides one Fibre Channel cable to connect a Fibre Channel/FICON adapter port to a server or fabric component port. Each cable has a LC connector for attachment to the Fibre Channel/FICON adapter port. The cables are available with a LC connector for attachment to the server or fabric component port. The 9 micron cables are compatible with long-wave Fibre Channel/FICON adapters.
AB22	2 meter, 9um Fibre cable (LC/SC)	Provides a pigtail conversion cable that can be used to attach the Fibre Channel/FICON adapter port to a cable with a LC connector. This feature is compatible with long-wave Fibre Channel/FICON host adapters.

Table 11. Feature codes for hardware features (continued)

Feature code	Feature	Description
AB23	3 meter, 9um Fibre cable (LC/LC)	Provides one Fibre Channel cable to connect a Fibre Channel/FICON adapter port to a server or fabric component port. Each cable has a LC connector for attachment to the Fibre Channel/FICON adapter port. The cables are available with a LC connector for attachment to the server or fabric component port. The 9 micron cables are compatible with long-wave Fibre Channel/FICON adapters.
AB30	40m zHyperLink cable	Provides one zHyperlink cable to connect a zHyperlink adapter port to a server or port of the zHyperLink Express feature. It is a single 24-fiber cable with Multi-fiber Termination Push-on (MTP) connectors. Internally, the cable houses 12 fibers for transmit and 12 fibers for receive. The specifications of the cable are: 40m, OM4 50/125 micrometer multimode fiber optic cable with a fiber bandwidth at wavelength: 4.7 GHz-km at 850 nm.
AB31	150m zHyperLink cable	Provides one zHyperlink cable to connect a zHyperlink adapter port to a server or port of the zHyperLink Express feature. It is a single 24-fiber cable with Multi-fiber Termination Push-on (MTP) connectors. Internally, the cable houses 12 fibers for transmit and 12 fibers for receive. The specifications of the cable are: 150m, OM4 50/125 micrometer multimode fiber optic cable with a fiber bandwidth at wavelength: 4.7 GHz-km at 850 nm.
AG00	Shipping and Handling NC	Indicates there won't be a shipping and handling charge added to the order. Note: Either this feature or the corresponding chargeable shipping and handling feature for this model must be selected in the order.
AGAK	Shipping and handling 994/A01	Indicates the box on the order will have a shipping and handling charge added to the order. Note: Either this feature or feature #AG00 must be selected in the order.
AGAL	Shipping and handling 996/A05	Indicates the box on the order will have a shipping and handling charge added to the order. Note: Either this feature or feature #AG00 must be selected in the order.

Table 11. Feature codes for hardware features (continued)

Feature code	Feature	Description
AGAM	Shipping and handling E96/E05	Indicates the box on the order will have a shipping and handling charge added to the order. Note: Either this feature or feature #AG00 must be selected in the order.
AHY1	Storage as a Service indicator	Indicates the machine is being deployed under a Storage as a Service offering. It is for administrative purposes only and does not affect the technical capabilities of the machine.
AHY2	On-site code load for Premium tier	Indicates that the customer requires someone to physically go on-site to do a code load upgrade by SSR. The feature quantity must match the number of years Expert Care Premium was ordered for.
AHY3	On-site code load for Advanced tier	Indicates that the customer requires someone to physically go on-site to do a code load upgrade by SSR. The feature quantity must match the number of years Expert Care Advanced feature that was ordered for.
AHY4	Remote Code Load for Advanced tier	Indicates that the customer requires a code load upgrade job done by a remote support engineer. The feature quantity must match the number of years Expert Care Advanced feature that was ordered for.
AKCH	Standard S&H Indicator	Indicates that the machine order will be shipped under the 'Standard' Shipping & Handling Service Level Agreement. The S&H cost is not charged under this feature code, but this serves as the mechanism to bring the cost into the quote and invoice as a bottom line cost.
AKNC	Premium S&H Indicator	Indicates that the machine order will be shipped under the 'Premium' Shipping & Handling Service Level Agreement. The S&H cost is not charged under this feature code, but this serves as the mechanism to bring the cost into the quote and invoice as a bottom line cost.
ALC9	4 year, IBM Storage Expert Care Advanced, 4hr Committed Fix	Indicates a priced Expert Care Service and Support offering is included on the order. It is for administrative purposes only.
ALCA	4 year, IBM Storage Expert Care Advanced, 6hr Committed Fix	Indicates a priced Expert Care Service and Support offering is included on the order. It is for administrative purposes only.

Table 11. Feature codes for hardware features (continued)

Feature code	Feature	Description
ALCB	4 year, IBM Storage Expert Care Advanced, 8hr Committed Fix	Indicates a priced Expert Care Service and Support offering is included on the order. It is for administrative purposes only.
ALCC	4 year, IBM Storage Expert Care Advanced, 12hr Committed Fix	Indicates a priced Expert Care Service and Support offering is included on the order. It is for administrative purposes only.
ALCD	4 year, IBM Storage Expert Care Advanced, 24hr Committed Fix	Indicates a priced Expert Care Service and Support offering is included on the order. It is for administrative purposes only.
ALCE	4 year, IBM Storage Expert Care Advanced, 48hr Committed Fix	Indicates a priced Expert Care Service and Support offering is included on the order. It is for administrative purposes only.
ALCF	4 year, IBM Storage Expert Care Advanced, 72hr Committed Fix	Indicates a priced Expert Care Service and Support offering is included on the order. It is for administrative purposes only.
ALCJ	5 year, IBM Storage Expert Care Advanced, 4hr Committed Fix	Indicates a priced Expert Care Service and Support offering is included on the order. It is for administrative purposes only.
ALCK	5 year, IBM Storage Expert Care Advanced, 6hr Committed Fix	Indicates a priced Expert Care Service and Support offering is included on the order. It is for administrative purposes only.
ALCL	5 year, IBM Storage Expert Care Advanced, 8hr Committed Fix	Indicates a priced Expert Care Service and Support offering is included on the order. It is for administrative purposes only.
ALCM	5 year, IBM Storage Expert Care Advanced, 12hr Committed Fix	Indicates a priced Expert Care Service and Support offering is included on the order. It is for administrative purposes only.
ALCN	5 year, IBM Storage Expert Care Advanced, 24hr Committed Fix	Indicates a priced Expert Care Service and Support offering is included on the order. It is for administrative purposes only.
ALCP	5 year, IBM Storage Expert Care Advanced, 48hr Committed Fix	Indicates a priced Expert Care Service and Support offering is included on the order. It is for administrative purposes only.
ALCQ	5 year, IBM Storage Expert Care Advanced, 72hr Committed Fix	Indicates a priced Expert Care Service and Support offering is included on the order. It is for administrative purposes only.
ALD9	4 year, IBM Storage Expert Care Premium, 4hr Committed Fix	Indicates a priced Expert Care Service and Support offering is included on the order. It is for administrative purposes only.
ALDA	4 year, IBM Storage Expert Care Premium, 6hr Committed Fix	Indicates a priced Expert Care Service and Support offering is included on the order. It is for administrative purposes only.
ALDB	4 year, IBM Storage Expert Care Premium, 8hr Committed Fix	Indicates a priced Expert Care Service and Support offering is included on the order. It is for administrative purposes only.

Table 11. Feature codes for hardware features (continued)

Feature code	Feature	Description
ALDC	4 year, IBM Storage Expert Care Premium, 12hr Committed Fix	Indicates a priced Expert Care Service and Support offering is included on the order. It is for administrative purposes only.
ALDD	4 year, IBM Storage Expert Care Premium, 24hr Committed Fix	Indicates a priced Expert Care Service and Support offering is included on the order. It is for administrative purposes only.
ALDE	4 year, IBM Storage Expert Care Premium, 48hr Committed Fix	Indicates a priced Expert Care Service and Support offering is included on the order. It is for administrative purposes only.
ALDF	4 year, IBM Storage Expert Care Premium, 72hr Committed Fix	Indicates a priced Expert Care Service and Support offering is included on the order. It is for administrative purposes only.
ALDJ	5 year, IBM Storage Expert Care Premium, 4hr Committed Fix	Indicates a priced Expert Care Service and Support offering is included on the order. It is for administrative purposes only.
ALDK	5 year, IBM Storage Expert Care Premium, 6hr Committed Fix	Indicates a priced Expert Care Service and Support offering is included on the order. It is for administrative purposes only.
ALDL	5 year, IBM Storage Expert Care Premium, 8hr Committed Fix	Indicates a priced Expert Care Service and Support offering is included on the order. It is for administrative purposes only.
ALDM	5 year, IBM Storage Expert Care Premium, 12hr Committed Fix	Indicates a priced Expert Care Service and Support offering is included on the order. It is for administrative purposes only.
ALDN	5 year, IBM Storage Expert Care Premium, 24hr Committed Fix	Indicates a priced Expert Care Service and Support offering is included on the order. It is for administrative purposes only.
ALDP	5 year, IBM Storage Expert Care Premium, 48hr Committed Fix	Indicates a priced Expert Care Service and Support offering is included on the order. It is for administrative purposes only.
ALDQ	5 year, IBM Storage Expert Care Premium, 72hr Committed Fix	Indicates a priced Expert Care Service and Support offering is included on the order. It is for administrative purposes only.
ALH0	Expert Care Indicator	Indicates a priced Expert Care Service and Support offering is included on the order. It is for administrative purposes only.
ALH4	Storage Utility Offering Indicator	Indicates the machine is being deployed as a Storage Utility Offering. It is for administrative purposes only and does not affect the technical capabilities of the machine.
ALK1	1yr Expert Care Advanced Indicator	Indicates a priced Expert Care Service and Support offering is included on the order. It is for administrative purposes only.

Table 11. Feature codes for hardware features (continued)

Feature code	Feature	Description
ALK2	2yr Expert Care Advanced Indicator	Indicates a priced Expert Care Service and Support offering is included on the order. It is for administrative purposes only.
ALK3	3yr Expert Care Advanced Indicator	Indicates a priced Expert Care Service and Support offering is included on the order. It is for administrative purposes only.
ALK4	4yr Expert Care Advanced Indicator	Indicates a priced Expert Care Service and Support offering is included on the order. It is for administrative purposes only.
ALK5	5yr Expert Care Advanced Indicator	Indicates a priced Expert Care Service and Support offering is included on the order. It is for administrative purposes only.
ALK9	1 year, IBM Storage Expert Care Advanced, 4hr Committed Fix	Indicates a priced Expert Care Service and Support offering is included on the order. It is for administrative purposes only.
ALKA	1 year, IBM Storage Expert Care Advanced, 6hr Committed Fix	Indicates a priced Expert Care Service and Support offering is included on the order. It is for administrative purposes only.
ALKB	1 year, IBM Storage Expert Care Advanced, 8hr Committed Fix	Indicates a priced Expert Care Service and Support offering is included on the order. It is for administrative purposes only.
ALKC	1 year, IBM Storage Expert Care Advanced, 12hr Committed Fix	Indicates a priced Expert Care Service and Support offering is included on the order. It is for administrative purposes only.
ALKD	1 year, IBM Storage Expert Care Advanced, 24hr Committed Fix	Indicates a priced Expert Care Service and Support offering is included on the order. It is for administrative purposes only.
ALKE	1 year, IBM Storage Expert Care Advanced, 48hr Committed Fix	Indicates a priced Expert Care Service and Support offering is included on the order. It is for administrative purposes only.
ALKF	1 year, IBM Storage Expert Care Advanced, 72hr Committed Fix	Indicates a priced Expert Care Service and Support offering is included on the order. It is for administrative purposes only.
ALKJ	2 year, IBM Storage Expert Care Advanced, 4hr Committed Fix	Indicates a priced Expert Care Service and Support offering is included on the order. It is for administrative purposes only.
ALKK	2 year, IBM Storage Expert Care Advanced, 6hr Committed Fix	Indicates a priced Expert Care Service and Support offering is included on the order. It is for administrative purposes only.
ALKL	2 year, IBM Storage Expert Care Advanced, 8hr Committed Fix	Indicates a priced Expert Care Service and Support offering is included on the order. It is for administrative purposes only.
ALKM	2 year, IBM Storage Expert Care Advanced, 12hr Committed Fix	Indicates a priced Expert Care Service and Support offering is included on the order. It is for administrative purposes only.

Table 11. Feature codes for hardware features (continued)

Feature code	Feature	Description
ALKN	2 year, IBM Storage Expert Care Advanced, 24hr Committed Fix	Indicates a priced Expert Care Service and Support offering is included on the order. It is for administrative purposes only.
ALKP	2 year, IBM Storage Expert Care Advanced, 48hr Committed Fix	Indicates a priced Expert Care Service and Support offering is included on the order. It is for administrative purposes only.
ALKQ	2 year, IBM Storage Expert Care Advanced, 72hr Committed Fix	Indicates a priced Expert Care Service and Support offering is included on the order. It is for administrative purposes only.
ALKT	3 year, IBM Storage Expert Care Advanced, 4hr Committed Fix	Indicates a priced Expert Care Service and Support offering is included on the order. It is for administrative purposes only.
ALKU	3 year, IBM Storage Expert Care Advanced, 6hr Committed Fix	Indicates a priced Expert Care Service and Support offering is included on the order. It is for administrative purposes only.
ALKV	3 year, IBM Storage Expert Care Advanced, 8hr Committed Fix	Indicates a priced Expert Care Service and Support offering is included on the order. It is for administrative purposes only.
ALKW	3 year, IBM Storage Expert Care Advanced, 12hr Committed Fix	Indicates a priced Expert Care Service and Support offering is included on the order. It is for administrative purposes only.
ALKX	3 year, IBM Storage Expert Care Advanced, 24hr Committed Fix	Indicates a priced Expert Care Service and Support offering is included on the order. It is for administrative purposes only.
ALKY	3 year, IBM Storage Expert Care Advanced, 48hr Committed Fix	Indicates a priced Expert Care Service and Support offering is included on the order. It is for administrative purposes only.
ALKZ	3 year, IBM Storage Expert Care Advanced, 72hr Committed Fix	Indicates a priced Expert Care Service and Support offering is included on the order. It is for administrative purposes only.
ALL1	1yr Expert Care Premium Indicator	Indicates a priced Expert Care Service and Support offering is included on the order. It is for administrative purposes only.
ALL2	2yr Expert Care Premium Indicator	Indicates a priced Expert Care Service and Support offering is included on the order. It is for administrative purposes only.
ALL3	3yr Expert Care Premium Indicator	Indicates a priced Expert Care Service and Support offering is included on the order. It is for administrative purposes only.
ALL4	4yr Expert Care Premium Indicator	Indicates a priced Expert Care Service and Support offering is included on the order. It is for administrative purposes only.
ALL5	5Yr Expert Care Premium Indicator	Indicates a priced Expert Care Service and Support offering is included on the order. It is for administrative purposes only.

Table 11. Feature codes for hardware features (continued)

Feature code	Feature	Description
ALL9	1 year, IBM Storage Expert Care Premium, 4hr Committed Fix	Indicates a priced Expert Care Service and Support offering is included on the order. It is for administrative purposes only.
ALLA	1 year, IBM Storage Expert Care Premium, 6hr Committed Fix	Indicates a priced Expert Care Service and Support offering is included on the order. It is for administrative purposes only.
ALLB	1 year, IBM Storage Expert Care Premium, 8hr Committed Fix	Indicates a priced Expert Care Service and Support offering is included on the order. It is for administrative purposes only.
ALLC	1 year, IBM Storage Expert Care Premium, 12hr Committed Fix	Indicates a priced Expert Care Service and Support offering is included on the order. It is for administrative purposes only.
ALLD	1 year, IBM Storage Expert Care Premium, 24hr Committed Fix	Indicates a priced Expert Care Service and Support offering is included on the order. It is for administrative purposes only.
ALLE	1 year, IBM Storage Expert Care Premium, 48hr Committed Fix	Indicates a priced Expert Care Service and Support offering is included on the order. It is for administrative purposes only.
ALLF	1 year, IBM Storage Expert Care Premium, 72hr Committed Fix	Indicates a priced Expert Care Service and Support offering is included on the order. It is for administrative purposes only.
ALLJ	2 year, IBM Storage Expert Care Premium, 4hr Committed Fix	Indicates a priced Expert Care Service and Support offering is included on the order. It is for administrative purposes only.
ALLK	2 year, IBM Storage Expert Care Premium, 6hr Committed Fix	Indicates a priced Expert Care Service and Support offering is included on the order. It is for administrative purposes only.
ALLL	2 year, IBM Storage Expert Care Premium, 8hr Committed Fix	Indicates a priced Expert Care Service and Support offering is included on the order. It is for administrative purposes only.
ALLM	2 year, IBM Storage Expert Care Premium, 12hr Committed Fix	Indicates a priced Expert Care Service and Support offering is included on the order. It is for administrative purposes only.
ALLN	2 year, IBM Storage Expert Care Premium, 24hr Committed Fix	Indicates a priced Expert Care Service and Support offering is included on the order. It is for administrative purposes only.
ALLP	2 year, IBM Storage Expert Care Premium, 48hr Committed Fix	Indicates a priced Expert Care Service and Support offering is included on the order. It is for administrative purposes only.
ALLQ	2 year, IBM Storage Expert Care Premium, 72hr Committed Fix	Indicates a priced Expert Care Service and Support offering is included on the order. It is for administrative purposes only.
ALLT	3 year, IBM Storage Expert Care Premium, 4hr Committed Fix	Indicates a priced Expert Care Service and Support offering is included on the order. It is for administrative purposes only.

Table 11. Feature codes for hardware features (continued)

Feature code	Feature	Description
ALLU	3 year, IBM Storage Expert Care Premium, 6hr Committed Fix	Indicates a priced Expert Care Service and Support offering is included on the order. It is for administrative purposes only.
ALLV	3 year, IBM Storage Expert Care Premium, 8hr Committed Fix	Indicates a priced Expert Care Service and Support offering is included on the order. It is for administrative purposes only.
ALLW	3 year, IBM Storage Expert Care Premium, 12hr Committed Fix	Indicates a priced Expert Care Service and Support offering is included on the order. It is for administrative purposes only.
ALLX	3 year, IBM Storage Expert Care Premium, 24hr Committed Fix	Indicates a priced Expert Care Service and Support offering is included on the order. It is for administrative purposes only.
ALLY	3 year, IBM Storage Expert Care Premium, 48hr Committed Fix	Indicates a priced Expert Care Service and Support offering is included on the order. It is for administrative purposes only.
ALLZ	3 year, IBM Storage Expert Care Premium, 72hr Committed Fix	Indicates a priced Expert Care Service and Support offering is included on the order. It is for administrative purposes only.
BONQ	SP Hard Drive/Media Retention - Storage 3 years	Indicates a priced ServicePac (machine type 666x) is included on the order. It is for administrative purposes only.
BOPF	SP Hard Drive/Media Retention - Storage 5 years	Indicates a priced ServicePac (machine type 666x) is included on the order. It is for administrative purposes only.
BAA0	BF 10TB increments from 0 to 100 TB	Enables a Base functions license subject to the client applying a feature activation code made available by IBM. It is also used for maintenance billing purposes. DS8000 Series Function Authorization feature numbers must be purchased to establish the extent of IBM authorization for the licensed function before the feature activation code is provided by IBM. As #BAxx features are ordered (plant and field install), the same #BAxx features (in the same quantity) must also be ordered against the Function Authorization machine type.

Table 11. Feature codes for hardware features (continued)

Feature code	Feature	Description
BAA1	BF 15TB increments from 100.1 TB to 250 TB	Enables a Base functions license subject to the client applying a feature activation code made available by IBM. It is also used for maintenance billing purposes. DS8000 Series Function Authorization feature numbers must be purchased to establish the extent of IBM authorization for the licensed function before the feature activation code is provided by IBM. As #BAxx features are ordered (plant and field install), the same #BAxx features (in the same quantity) must also be ordered against the Function Authorization machine type.
BAA2	BF 25TB increments from 250.1 TB to 500 TB	Enables a Base functions license subject to the client applying a feature activation code made available by IBM. It is also used for maintenance billing purposes. DS8000 Series Function Authorization feature numbers must be purchased to establish the extent of IBM authorization for the licensed function before the feature activation code is provided by IBM. As #BAxx features are ordered (plant and field install), the same #BAxx features (in the same quantity) must also be ordered against the Function Authorization machine type.
BAA3	BF 75TB increments from 500.1 TB to 1250 TB	Enables a Base functions license subject to the client applying a feature activation code made available by IBM. It is also used for maintenance billing purposes. DS8000 Series Function Authorization feature numbers must be purchased to establish the extent of IBM authorization for the licensed function before the feature activation code is provided by IBM. As #BAxx features are ordered (plant and field install), the same #BAxx features (in the same quantity) must also be ordered against the Function Authorization machine type.

Table 11. Feature codes for hardware features (continued)

Feature code	Feature	Description
BAA4	BF 175TB increments from 1250.1 TB to 3000 TB	Enables a Base functions license subject to the client applying a feature activation code made available by IBM. It is also used for maintenance billing purposes. DS8000 Series Function Authorization feature numbers must be purchased to establish the extent of IBM authorization for the licensed function before the feature activation code is provided by IBM. As #BAxx features are ordered (plant and field install), the same #BAxx features (in the same quantity) must also be ordered against the Function Authorization machine type.
BAA5	BF 300TB increments from 3000.1 TB to 6000 TB	Enables a Base functions license subject to the client applying a feature activation code made available by IBM. It is also used for maintenance billing purposes. DS8000 Series Function Authorization feature numbers must be purchased to establish the extent of IBM authorization for the licensed function before the feature activation code is provided by IBM. As #BAxx features are ordered (plant and field install), the same #BAxx features (in the same quantity) must also be ordered against the Function Authorization machine type.
BAA6	BF 600TB increments from 6000.1 TB to 12000 TB	Enables a Base functions license subject to the client applying a feature activation code made available by IBM. It is also used for maintenance billing purposes. DS8000 Series Function Authorization feature numbers must be purchased to establish the extent of IBM authorization for the licensed function before the feature activation code is provided by IBM. As #BAxx features are ordered (plant and field install), the same #BAxx features (in the same quantity) must also be ordered against the Function Authorization machine type.
BAB0	CS - Inactive	Indicates Copy services functions are inactive in the unit.

Table 11. Feature codes for hardware features (continued)

Feature code	Feature	Description
BAB1	CS 10TB increments from 0 to 100 TB	Enables a Copy Services functions license subject to the client applying a feature activation code made available by IBM. It is also used for maintenance billing purposes. DS8000 Series Function Authorization feature numbers must be purchased to establish the extent of IBM authorization for the licensed function before the feature activation code is provided by IBM. As #BAxx features are ordered (plant and field install), the same #BAxx features (in the same quantity) must also be ordered against the Function Authorization machine type.
BAB2	CS 15TB increments from 100.1 TB to 250 TB	Enables a Copy Services functions license subject to the client applying a feature activation code made available by IBM. It is also used for maintenance billing purposes. DS8000 Series Function Authorization feature numbers must be purchased to establish the extent of IBM authorization for the licensed function before the feature activation code is provided by IBM. As #BAxx features are ordered (plant and field install), the same #BAxx features (in the same quantity) must also be ordered against the Function Authorization machine type.
BAB3	CS 25TB increments from 250.1 TB to 500 TB	Enables a Copy Services functions license subject to the client applying a feature activation code made available by IBM. It is also used for maintenance billing purposes. DS8000 Series Function Authorization feature numbers must be purchased to establish the extent of IBM authorization for the licensed function before the feature activation code is provided by IBM. As #BAxx features are ordered (plant and field install), the same #BAxx features (in the same quantity) must also be ordered against the Function Authorization machine type.

Table 11. Feature codes for hardware features (continued)

Feature code	Feature	Description
BAB4	CS 75TB increments from 500.1 TB to 1250 TB	Enables a Copy Services functions license subject to the client applying a feature activation code made available by IBM. It is also used for maintenance billing purposes. DS8000 Series Function Authorization feature numbers must be purchased to establish the extent of IBM authorization for the licensed function before the feature activation code is provided by IBM. As #BAxx features are ordered (plant and field install), the same #BAxx features (in the same quantity) must also be ordered against the Function Authorization machine type.
BAB5	CS 175TB increments from 1250.1 TB to 3000 TB	Enables a Copy Services functions license subject to the client applying a feature activation code made available by IBM. It is also used for maintenance billing purposes. DS8000 Series Function Authorization feature numbers must be purchased to establish the extent of IBM authorization for the licensed function before the feature activation code is provided by IBM. As #BAxx features are ordered (plant and field install), the same #BAxx features (in the same quantity) must also be ordered against the Function Authorization machine type.
BAB6	CS 300TB increments from 3000.1 TB to 6000 TB	Enables a Copy Services functions license subject to the client applying a feature activation code made available by IBM. It is also used for maintenance billing purposes. DS8000 Series Function Authorization feature numbers must be purchased to establish the extent of IBM authorization for the licensed function before the feature activation code is provided by IBM. As #BAxx features are ordered (plant and field install), the same #BAxx features (in the same quantity) must also be ordered against the Function Authorization machine type.

Table 11. Feature codes for hardware features (continued)

Feature code	Feature	Description
BAB7	CS 600TB increments from 6000.1 TB to 12000 TB	Enables a Copy Services functions license subject to the client applying a feature activation code made available by IBM. It is also used for maintenance billing purposes. DS8000 Series Function Authorization feature numbers must be purchased to establish the extent of IBM authorization for the licensed function before the feature activation code is provided by IBM. As #BAxx features are ordered (plant and field install), the same #BAxx features (in the same quantity) must also be ordered against the Function Authorization machine type.
BAC0	zsS - Active	Indicates Z synergy services functions are active in the unit.
BAC1	zsS - Inactive	Indicates Z synergy services functions are inactive in the unit.
BAC2	zsS 10TB increments from 0 to 100 TB	Enables a z Synergy services license subject to the client applying a feature activation code made available by IBM. It is also used for maintenance billing purposes. DS8000 Series Function Authorization feature numbers must be purchased to establish the extent of IBM authorization for the licensed function before the feature activation code is provided by IBM. As #BAxx features are ordered (plant and field install), the same #BAxx features (in the same quantity) must also be ordered against the Function Authorization machine type.
BAC3	zsS 15TB increments from 100.1 TB to 250 TB	Enables a z Synergy services license subject to the client applying a feature activation code made available by IBM. It is also used for maintenance billing purposes. DS8000 Series Function Authorization feature numbers must be purchased to establish the extent of IBM authorization for the licensed function before the feature activation code is provided by IBM. As #BAxx features are ordered (plant and field install), the same #BAxx features (in the same quantity) must also be ordered against the Function Authorization machine type.

Table 11. Feature codes for hardware features (continued)

Feature code	Feature	Description
BAC4	zsS 25TB increments from 250.1 TB to 500 TB	Enables a z Synergy services license subject to the client applying a feature activation code made available by IBM. It is also used for maintenance billing purposes. DS8000 Series Function Authorization feature numbers must be purchased to establish the extent of IBM authorization for the licensed function before the feature activation code is provided by IBM. As #BAxx features are ordered (plant and field install), the same #BAxx features (in the same quantity) must also be ordered against the Function Authorization machine type.
BAC5	zsS 75TB increments from 500.1 TB to 1250 TB	Enables a z Synergy services license subject to the client applying a feature activation code made available by IBM. It is also used for maintenance billing purposes. DS8000 Series Function Authorization feature numbers must be purchased to establish the extent of IBM authorization for the licensed function before the feature activation code is provided by IBM. As #BAxx features are ordered (plant and field install), the same #BAxx features (in the same quantity) must also be ordered against the Function Authorization machine type.
BAC6	zsS 175TB increments from 1250.1 TB to 3000 TB	Enables a z Synergy services license subject to the client applying a feature activation code made available by IBM. It is also used for maintenance billing purposes. DS8000 Series Function Authorization feature numbers must be purchased to establish the extent of IBM authorization for the licensed function before the feature activation code is provided by IBM. As #BAxx features are ordered (plant and field install), the same #BAxx features (in the same quantity) must also be ordered against the Function Authorization machine type.

Table 11. Feature codes for hardware features (continued)

Feature code	Feature	Description
BAC7	zsS 300TB increments from 3000.1 TB to 6000 TB	Enables a z Synergy services license subject to the client applying a feature activation code made available by IBM. It is also used for maintenance billing purposes. DS8000 Series Function Authorization feature numbers must be purchased to establish the extent of IBM authorization for the licensed function before the feature activation code is provided by IBM. As #BAxx features are ordered (plant and field install), the same #BAxx features (in the same quantity) must also be ordered against the Function Authorization machine type.
BAC8	zsS 600TB increments from 6000.1 TB to 12000 TB	Enables a z Synergy services license subject to the client applying a feature activation code made available by IBM. It is also used for maintenance billing purposes. DS8000 Series Function Authorization feature numbers must be purchased to establish the extent of IBM authorization for the licensed function before the feature activation code is provided by IBM. As #BAxx features are ordered (plant and field install), the same #BAxx features (in the same quantity) must also be ordered against the Function Authorization machine type.
BAD0	TCT - Active	Indicates Transparent Cloud Tiering services functions are active in the unit.
BAD1	TCT - Inactive	Indicates Transparent Cloud Tiering services functions are inactive in the unit.
BAD2	TCT 10TB increments from 0 to 100 TB	Enables a Transparent Cloud Tiering services license subject to the client applying a feature activation code made available by IBM. It is also used for maintenance billing purposes. DS8000 Series Function Authorization feature numbers must be purchased to establish the extent of IBM authorization for the licensed function before the feature activation code is provided by IBM. As #BAxx features are ordered (plant and field install), the same #BAxx features (in the same quantity) must also be ordered against the Function Authorization machine type.

Table 11. Feature codes for hardware features (continued)

Feature code	Feature	Description
BAD3	TCT 15TB increments from 100.1 TB to 250 TB	Enables a Transparent Cloud Tiering services license subject to the client applying a feature activation code made available by IBM. It is also used for maintenance billing purposes. DS8000 Series Function Authorization feature numbers must be purchased to establish the extent of IBM authorization for the licensed function before the feature activation code is provided by IBM. As #BAxx features are ordered (plant and field install), the same #BAxx features (in the same quantity) must also be ordered against the Function Authorization machine type.
BAD4	TCT 25TB increments from 250.1 TB to 500 TB	Enables a Transparent Cloud Tiering services license subject to the client applying a feature activation code made available by IBM. It is also used for maintenance billing purposes. DS8000 Series Function Authorization feature numbers must be purchased to establish the extent of IBM authorization for the licensed function before the feature activation code is provided by IBM. As #BAxx features are ordered (plant and field install), the same #BAxx features (in the same quantity) must also be ordered against the Function Authorization machine type.
BAD5	TCT 75TB increments from 500.1 TB to 1250 TB	Enables a Transparent Cloud Tiering services license subject to the client applying a feature activation code made available by IBM. It is also used for maintenance billing purposes. DS8000 Series Function Authorization feature numbers must be purchased to establish the extent of IBM authorization for the licensed function before the feature activation code is provided by IBM. As #BAxx features are ordered (plant and field install), the same #BAxx features (in the same quantity) must also be ordered against the Function Authorization machine type.

Table 11. Feature codes for hardware features (continued)

Feature code	Feature	Description
BAD6	TCT 175TB increments from 1250.1 TB to 3000 TB	Enables a Transparent Cloud Tiering services license subject to the client applying a feature activation code made available by IBM. It is also used for maintenance billing purposes. DS8000 Series Function Authorization feature numbers must be purchased to establish the extent of IBM authorization for the licensed function before the feature activation code is provided by IBM. As #BAxx features are ordered (plant and field install), the same #BAxx features (in the same quantity) must also be ordered against the Function Authorization machine type.
BAD7	TCT 300TB increments from 3000.1 TB to 6000 TB	Enables a Transparent Cloud Tiering services license subject to the client applying a feature activation code made available by IBM. It is also used for maintenance billing purposes. DS8000 Series Function Authorization feature numbers must be purchased to establish the extent of IBM authorization for the licensed function before the feature activation code is provided by IBM. As #BAxx features are ordered (plant and field install), the same #BAxx features (in the same quantity) must also be ordered against the Function Authorization machine type.
BAD8	TCT 600T increments from 6000.1 TB to 12000 TB	Enables a Transparent Cloud Tiering services license subject to the client applying a feature activation code made available by IBM. It is also used for maintenance billing purposes. DS8000 Series Function Authorization feature numbers must be purchased to establish the extent of IBM authorization for the licensed function before the feature activation code is provided by IBM. As #BAxx features are ordered (plant and field install), the same #BAxx features (in the same quantity) must also be ordered against the Function Authorization machine type.
CAA0	E05 factory merge	Indicates an expansion unit model is being ordered with the initial order of the base unit model, and notifies manufacturing that a factory merge of the base unit and expansion unit is required. This feature is for administrative purposes only.

Table 11. Feature codes for hardware features (continued)

Feature code	Feature	Description
CAA1	E05 field merge	Indicates an expansion unit model is being ordered for a base unit model in the field, and notifies manufacturing that a field merge of the base unit and expansion unit is required. This feature is for administrative purposes only.
CAA2	4.8 TB FCM drive set flash encl indicator	Notifies manufacturing on the number of high-performance flash enclosures used to support 4.8 TB FCM drive sets. It is for administrative purposes only. User needs to indicate how many high-performance flash enclosures are required based on the type of flash drive selected.
CAA3	9.6 TB FCM drive set flash encl indicator	Notifies manufacturing on the number of high-performance flash enclosures used to support 9.6 TB FCM drive sets. It is for administrative purposes only. User needs to indicate how many high-performance flash enclosures are required based on the type of flash drive selected.
CAA4	19.2 TB FCM drive set flash encl indicator	Notifies manufacturing on the number of high-performance flash enclosures used to support 19.2 TB FCM drive sets. It is for administrative purposes only. User needs to indicate how many high-performance flash enclosures are required based on the type of flash drive selected.
CAA5	E05 presence indicator	Indicates the presence of an attached Model E05 expansion unit. It is used to determine multi-model system configuration rules, including cross-model feature corequisites. Incorrect use of this feature can result in the creation and shipment of incorrect and/or incomplete configurations. Therefore, it must be added or removed if changes are made to the system-level configuration.

Management console

The management console supports storage system hardware and firmware installation and maintenance activities.

The management console is a dedicated processor unit that is located inside your storage system. The management console can automatically monitor the state of your system, and notify you and IBM® when service is needed.

To provide continuous availability two management consoles are provided. The on site interface to the management console is a 1U keyboard and display. (feature code AAK0).

Hardware specifics

The storage system models offer a high degree of availability and performance through the use of redundant components that can be replaced while the system is operating. You can use a storage system model with a mix of different operating systems and clustered and nonclustered variants of the same operating systems.

Contributors to the high degree of availability and reliability include the structure of the storage unit, the host systems that are supported, and the memory and speed of the processors.

Storage system structure

The design of the storage system contributes to the high degree of availability. The primary components that support high availability within the storage system are the storage server, the processor node, and the power control card.

Storage system

The storage system contains a storage server and one or more pair of storage enclosures that are packaged in one or more frames with associated power supplies, batteries, and cooling.

Storage server

The storage server consists of two processor nodes, two or more I/O enclosures, and a pair of power control cards.

Processor node

The processor node controls and manages the storage server functions in the storage system. The two processor nodes form a redundant pair such that if either processor node fails, the remaining processor node controls and manages all storage server functions.

Power control card

A redundant pair of power control cards located in the Management enclosure coordinate the power management within the storage unit. The power control cards are attached to the service processors in each processor node and iPDU pair.

Flash drives

The storage system offers you a selection of drives.

The new high performance flash enclosure pairs can support both Industry Standard NVMe flash drives media and IBM FlashCore Modules (FCM) with built-in compression.

With the improved performance provided by the new RAID Adapters and NVMe drives it is expected that users migrating from previous generation storage systems will be able to move to a larger drive size than they are currently using. IBM Storage Modeller should be used to confirm that a particular configuration will meet workload requirements.

The following NVMe industry-standard drives are supported in DS8000 10th generation systems:

- 1.6 TB 2.5-inch NVMe flash drive
- 1.92 TB 2.5-inch NVMe flash drive
- 3.84 TB 2.5-inch NVMe flash drive
- 7.68 TB 2.5-inch NVMe flash drive

The following FlashCore Module drives are supported in DS8000 10th generation systems:

- 4.8 TB 2.5-inch NVMe FlashCore Module
- 9.6 TB 2.5-inch NVMe FlashCore Module
- 19.2 TB 2.5-inch NVMe FlashCore Module

Drive maintenance policy

A minimum of two spare drives are allocated in a device adapter loop.

Internal maintenance functions continuously monitor and report (by using the call home feature) to IBM when the number of drives in a spare pool reaches a preset threshold. This design ensures continuous availability of devices while it protects data and minimizing any service disruptions.

It is not recommended to replace a drive unless an event is generated indicating that service is needed.

Host attachment overview

The storage system provides various host attachments so that you can consolidate storage capacity and workloads for open-systems hosts and IBM Z.

The storage system provides extensive connectivity using Fibre Channel adapters across a broad range of server environments.

Host adapter intermix support

Models A01 and A05

The following table shows the host adapter plug order.

PSU0	P1-C1		PSU1	P1-C2		XI3
	P1-C3 1			P1-C4 3		
	P1-C5 5			P1-C6 7		
P1-C7-C1		P1-C7		P1-C7-C2		
PSU0	P1-C1		PSU1	P1-C2		XI4
	P1-C3 2			P1-C4 4		
	P1-C5 6			P1-C6 8		
P1-C7-C1		P1-C7		P1-C7-C2		

PSU0	P1-C1		PSU1	P1-C2		XI1
	P1-C3 3			P1-C4 7		
	P1-C5 11			P1-C6 15		
P1-C7-C1		P1-C7		P1-C7-C2		
PSU0	P1-C1		PSU1	P1-C2		XI2
	P1-C3 4			P1-C4 8		
	P1-C5 12			P1-C6 16		
P1-C7-C1		P1-C7		P1-C7-C2		

PSU0	P1-C1		PSU1	P1-C2		XI3
	P1-C3 1			P1-C4 5		
	P1-C5 9			P1-C6 13		
P1-C7-C1		P1-C7		P1-C7-C2		
PSU0	P1-C1		PSU1	P1-C2		XI4
	P1-C3 2			P1-C4 6		
	P1-C5 10			P1-C6 14		
P1-C7-C1		P1-C7		P1-C7-C2		

Figure 5. Host adapter plug order, two I/O bay pair rack

Figure 4. Host adapter plug order, single I/O bay pair rack

The following HA-type plug order is used during manufacturing when different types of HA cards are installed.

1. 4-port 32 Gbps longwave host adapters
2. 4-port 32 Gbps shortwave host adapters

Open-systems host attachment with Fibre Channel adapters

You can attach a storage system to an open-systems host with Fibre Channel adapters.

The storage system supports SAN speeds of up to 32 Gbps with the current 32 Gbps host adapters. The storage system detects and operates at the greatest available link speed that is shared by both sides of the system.

Fibre Channel technology transfers data between the sources and the users of the information. Fibre Channel connections are established between Fibre Channel ports that reside in I/O devices, host

systems, and the network that interconnects them. The network consists of elements like switches, bridges, and repeaters that are used to interconnect the Fibre Channel ports.

FICON attached IBM Z hosts overview

The storage system can be attached to FICON® attached IBM® Z host operating systems under specified adapter configurations.

Each storage system Fibre Channel adapter has four ports. Each port has a unique worldwide port name (WWPN). You can configure the port to operate with the FICON upper-layer protocol.

With Fibre Channel adapters that are configured for FICON, the storage system provides the following configurations:

- Either fabric or point-to-point topologies
- A maximum of 64 ports on model A01, or A05 (without expansion model E05), and 128 ports on model A05 with an expansion model E05.
- A maximum of 509 logins per Fibre Channel port
- A maximum of 8,192 logins per storage system
- A maximum of 1,280 logical paths on each Fibre Channel port
- Access to all 255 control-unit images (65,280 CKD devices) over each FICON port
- A maximum of 512 logical paths per control unit image

Note: IBM z13®, IBM z14® and IBM z15 servers support 32,768 devices per FICON host channel, while IBM zEnterprise® EC12 and IBM zEnterprise BC12 servers support 24,576 devices per FICON host channel. Earlier IBM Z servers support 16,384 devices per FICON host channel. To fully access 65,280 devices, it is necessary to connect multiple FICON host channels to the storage system. You can access the devices through a Fibre Channel switch or FICON director to a single storage system FICON port.

The storage system supports the following operating systems for IBM Z hosts:

- Linux®
- Transaction Processing Facility (TPF)
- Virtual Storage Extended/Enterprise Storage Architecture
- z/OS®
- z/VM®
- z/VSE®

For the most current information on supported hosts, operating systems, adapters, and switches, go to the [IBM System Storage® Interoperation Center \(SSIC\) website\(www-03.ibm.com/systems/support/storage/ssic/interoperability.was\)](http://www-03.ibm.com/systems/support/storage/ssic/interoperability.was).

I/O load balancing

You can maximize the performance of an application by spreading the I/O load across processor nodes, arrays, and device adapters in the storage system.

During an attempt to balance the load within the storage system, placement of application data is the determining factor. The following resources are the most important to balance, roughly in order of importance:

- Activity to the RAID drive groups. Use as many RAID drive groups as possible for the critical applications. Most performance bottlenecks occur because a few drive are overloaded. Spreading an application across multiple RAID drive groups ensures that as many drives as possible are available. This is extremely important for open-system environments where cache-hit ratios are usually low.
- Activity to the nodes. When selecting RAID drive groups for a critical application, spread them across separate nodes. Because each node has separate memory buses and cache memory, this maximizes the use of those resources.

- Activity to the device adapters. When selecting RAID drive groups within a cluster for a critical application, spread them across separate device adapters.
- Activity to the Fibre Channel ports.

Storage consolidation

When you use a storage system, you can consolidate data and workloads from different types of independent hosts into a single shared resource.

You can mix production and test servers in an open systems environment or mix open systems and IBM Z hosts. In this type of environment, servers rarely, if ever, contend for the same resource.

Although sharing resources in the storage system has advantages for storage administration and resource sharing, there are more implications for workload planning. The benefit of sharing is that a larger resource pool (for example, drives or cache) is available for critical applications. However, you must ensure that uncontrolled or unpredictable applications do not interfere with critical work. This requires the same workload planning that you use when you mix various types of work on a server.

If your workload is critical, consider isolating it from other workloads. To isolate the workloads, place the data as follows:

- On separate RAID drive groups. Data for open systems or IBM Z hosts is automatically placed on separate arrays, which reduce the contention for drive use.
- On separate device adapters.
- In separate processor nodes, which isolate use of memory buses, microprocessors, and cache resources. Before you decide, verify that the isolation of your data to a single node provides adequate data access performance for your application.

Count key data

In count-key-data (CKD) disk data architecture, the data field stores the user data.

Because data records can be variable in length, in CKD they all have an associated count field that indicates the user data record size. The key field enables a hardware search on a key. The commands used in the CKD architecture for managing the data and the storage devices are called channel command words.

Fixed block

In fixed block (FB) architecture, the data (the logical volumes) are mapped over fixed-size blocks or sectors.

With an FB architecture, the location of any block can be calculated to retrieve that block. This architecture uses tracks and cylinders. A physical disk contains multiple blocks per track, and a cylinder is the group of tracks that exists under the disk heads at one point in time without performing a seek operation.

T10 DIF support

American National Standards Institute (ANSI) T10 Data Integrity Field (DIF) standard is supported on IBM Z for SCSI end-to-end data protection on fixed block (FB) LUN volumes. This support applies to the IBM Storage DS8000 (10th Generation) A0x models. IBM Z support applies to FCP channels only.

IBM Z provides added end-to-end data protection between the operating system and the DS8A00 unit. This support adds protection information consisting of CRC (Cyclic Redundancy Checking), LBA (Logical Block Address), and host application tags to each sector of FB data on a logical volume.

Data protection using the T10 Data Integrity Field (DIF) on FB volumes includes the following features:

- Ability to convert logical volume formats between standard and protected formats supported through PPRC between standard and protected volumes

- Support for earlier versions of T10-protected volumes on the DS8A00 with non T10 DIF-capable hosts
- Allows end-to-end checking at the application level of data stored on FB disks
- Additional metadata stored by the storage facility image (SFI) allows host adapter-level end-to-end checking data to be stored on FB disks independently of whether the host uses the DIF format.

Notes:

- This feature requires changes in the I/O stack to take advantage of all the capabilities the protection offers.
- T10 DIF volumes can be used by any type of Open host with the exception of iSeries, but active protection is supported only for Linux® on IBM Z or AIX on IBM Power Systems. The protection can only be active if the host server has T10 DIF enabled.
- T10 DIF volumes can accept SCSI I/O of either T10 DIF or standard type, but if the FB volume type is standard, then only standard SCSI I/O is accepted.

Logical volumes

A logical volume is the storage medium that is associated with a logical disk. It typically resides on two or more hard disk drives.

For the storage unit, the logical volumes are defined at logical configuration time. For count-key-data (CKD) servers, the logical volume size is defined by the device emulation mode and model. For fixed block (FB) hosts, you can define each FB volume (LUN) with a minimum size of a single block (512 bytes) to a maximum size of 2³² blocks or 16 TB.

A logical device that has nonremovable media has one and only one associated logical volume. A logical volume is composed of one or more extents. Each extent is associated with a contiguous range of addressable data units on the logical volume.

Allocation, deletion, and modification of volumes

Extent allocation methods (namely, rotate volumes and pool striping) determine the means by which actions are completed on storage system volumes.

All extents of the ranks assigned to an extent pool are independently available for allocation to logical volumes. The extents for a LUN or volume are logically ordered, but they do not have to come from one rank and the extents do not have to be contiguous on a rank. This construction method of using fixed extents to form a logical volume in the storage system allows flexibility in the management of the logical volumes. You can delete volumes, resize volumes, and reuse the extents of those volumes to create other volumes, different sizes. One logical volume can be deleted without affecting the other logical volumes defined on the same extent pool.

Because the extents are cleaned (overwritten with zeros) after you delete a volume, it can take some time until these extents are available for reallocation for volume specific metadata. The reformatting of the extents is a background process.

There are two extent allocation methods used by the storage system: rotate volumes and storage pool striping (rotate extents).

Storage pool striping: extent rotation

The default storage allocation method is storage pool striping. The extents of a volume can be striped across several ranks. The storage system keeps a sequence of ranks. The first rank in the list is randomly picked at each power on of the storage subsystem. The storage system tracks the rank in which the last allocation started. The allocation of a first extent for the next volume starts from the next rank in that sequence. The next extent for that volume is taken from the next rank in sequence, and so on. The system rotates the extents across the ranks.

If you migrate an existing non-striped volume to the same extent pool with a rotate extents allocation method, then the volume is "reorganized." If you add more ranks to an existing extent pool, then the "reorganizing" existing striped volumes spreads them across both existing and new ranks.

You can configure and manage storage pool striping using the DS Storage Manager, and DS CLI, and DS Open API. The default of the extent allocation method (EAM) option that is allocated to a logical volume is now rotate extents. The rotate extents option is designed to provide the best performance by striping volume extents across ranks in extent pool.

Managed EAM: Once a volume is managed by Easy Tier, the EAM of the volume is changed to managed EAM, which can result in placement of the extents differing from the rotate volume and rotate extent rules. The EAM only changes when a volume is manually migrated to a non-managed pool.

Rotate volumes allocation method

Extents can be allocated sequentially. In this case, all extents are taken from the same rank until there are enough extents for the requested volume size or the rank is full, in which case the allocation continues with the next rank in the extent pool.

If more than one volume is created in one operation, the allocation for each volume starts in another rank. When allocating several volumes, rotate through the ranks. You might want to consider this allocation method when you prefer to manage performance manually. The workload of one volume is going to one rank. This method makes the identification of performance bottlenecks easier; however, by putting all the volumes data onto just one rank, you might introduce a bottleneck, depending on your actual workload.

LUN calculation

The storage system uses a provisioned capacity algorithm (calculation) to provide a logical unit number (LUN).

In the storage system, usable storage capacities are expressed in powers of 10. Logical or effective storage capacities (logical volumes, ranks, extent pools) and processor memory capacities are expressed in powers of 2. Both of these conventions are used for logical volume effective storage capacities.

On open volumes with 512 byte blocks (including T10-protected volumes), you can specify an exact block count to create a LUN. You can specify a standard LUN size (which is expressed as an exact number of binary GiBs (2^{30})) or you can specify an ESS volume size (which is expressed in decimal GiBs (10^9) accurate to 0.1 GB). The unit of storage allocation for fixed block open systems volumes is one extent. The extent sizes for open volumes is either exactly 1 GiB, or 16 MiB. Any logical volume that is not an exact multiple of 1 GiB does not use all the capacity in the last extent that is allocated to the logical volume. Supported block counts are from 1 to 4 194 304 blocks (2 binary TiB) in increments of one block. Supported sizes are from 1 to 16 TiB in increments of 1 GiB. The supported ESS LUN sizes are limited to the exact sizes that are specified from 0.1 to 982.2 GB (decimal) in increments of 0.1 GB and are rounded up to the next larger 32 K byte boundary. The ESS LUN sizes do not result in standard LUN sizes. Therefore, they can waste capacity. However, the unused capacity is less than one full extent. ESS LUN sizes are typically used when volumes must be copied between the storage system and ESS.

On open volumes with 520 byte blocks, you can select one of the supported LUN sizes that are used on IBM i processors to create a LUN. The operating system uses 8 of the bytes in each block. This leaves 512 bytes per block for your data. Variable volume sizes are also supported.

Table 12 on page 58 shows the disk capacity for the protected and unprotected models. Logically unprotecting a storage LUN allows the IBM i host to start system level mirror protection on the LUN. The IBM i system level mirror protection allows normal system operations to continue running in the event of a failure in an HBA, fabric, connection, or LUN on one of the LUNs in the mirror pair.

Note: On IBM i, logical volume sizes in the range 17.5 GB to 141.1 GB are supported as load source units. Logical volumes smaller than 17.5 GB or larger than 141.1 GB cannot be used as load source units.

Table 12. Capacity and models of disk volumes for IBM i hosts running IBM i operating system

Size	Protected model	Unprotected model
8.5 GB	A01	A81
17.5 GB	A02	A82
35.1 GB	A05	A85
70.5 GB	A04	A84
141.1 GB	A06	A86
282.2 GB	A07	A87
1 GB to 2000 GB	099	050

On CKD volumes, you can specify an exact cylinder count or a standard volume size to create a LUN. The standard volume size is expressed as an exact number of Mod 1 equivalents (which is 1113 cylinders). The unit of storage allocation for CKD volumes is one CKD extent. The extent size for a CKD volume is either exactly a Mod-1 equivalent (which is 1113 cylinders), or it is 21 cylinders when using the small-extents option. Any logical volume that is not an exact multiple of 1113 cylinders (1 extent) does not use all the capacity in the last extent that is allocated to the logical volume. For CKD volumes that are created with 3380 track formats, the number of cylinders (or extents) is limited to either 2226 (1 extent) or 3339 (2 extents). For CKD volumes that are created with 3390 track formats, you can specify the number of cylinders in the range of 1 - 65520 (x'0001' - x'FFF0') in increments of one cylinder, for a standard (non-EAV) 3390. The allocation of an EAV volume is expressed in increments of 3390 mod1 capacities (1113 cylinders) and can be expressed as integral multiples of 1113 between 65,667 - 1,182,006 cylinders or as the number of 3390 mod1 increments in the range of 59 - 1062.

Extended address volumes for CKD

Count key data (CKD) volumes now support the additional capacity of 1 TB. The 1 TB capacity is an increase in volume size from the previous 223 GB.

This increased provisioned capacity is referred to as extended address volumes (EAV) and is supported by the 3390 Model A. Use a maximum size volume of up to 1,182,006 cylinders for the IBM z/OS. This support is available to you for the z/OS version 12.1 and later.

You can create a 1 TB IBM Z CKD volume. An IBM Z CKD volume is composed of one or more extents from a CKD extent pool. CKD large extents are 1113 cylinders and small extents are 21 cylinders in size. When you define a IBM Z CKD volume, you must specify the number of cylinders that you want for the volume. The storage system and the z/OS have limits for the CKD EAV sizes. You can define CKD volumes with up to 1,182,006 cylinders, about 1 TB on the DS8A00.

For maximum storage efficiency, consider allocating volumes that are exact multiples of 21 cylinders (for small extents) or 1113 cylinders (for large extents). If the number of cylinders that you specify is not an exact multiple of 21 or 1113 cylinders, then some space in the last allocated extent is wasted.

Quick initialization

Quick initialization improves device initialization speed and allows a Copy Services relationship to be established after a device is created.

Quick volume initialization for IBM Z environments is supported. This support helps users who frequently delete volumes by reconfiguring capacity without waiting for initialization. Quick initialization initializes the data logical tracks or block within a specified extent range on a logical volume with the appropriate initialization pattern for the host.

Normal read and write access to the logical volume is allowed during the initialization process. Therefore, the extent metadata must be allocated and initialized before the quick initialization function is started.

Depending on the operation, the quick initialization can be started for the entire logical volume or for an extent range on the logical volume.

Chapter 3. Data management features

The storage system is designed with many management features that allow you to securely process and access your data according to your business needs, even if it is 24 hours a day and 7 days a week.

This section contains information about the data management features in your storage system. Use the information in this section to assist you in planning, ordering licenses, and in the management of your storage system data management features.

Transparent cloud tiering

Transparent cloud tiering is a licensed function that enables volume data to be copied and transferred to cloud storage. DS8000 transparent cloud tiering is a feature in conjunction with z/OS and DFSMSHsm that provides server-less movement of archive and backup data directly to an object storage solution. Offloading the movement of the data from the host to the DS8000 unlocks DFSMSHsm efficiencies and saves z/OS CPU cycles.

DFSMSHsm has been the leading z/OS data archive solution for over 30 years. Its architecture is designed and optimized for tape, being the medium in which the data is transferred and archived.

Due to this architectural design point, there are inherent inefficiencies that consume host CPU cycles, including the following examples:

Movement of data through the host

All of the data must move from the disk through the host and out to the tape device.

Dual Data Movement

DSS must read the data from the disk and then pass the data from DSS to HSM, which then moves the data from the host to the tape.

16K block sizes

HSM separates the data within z/OS into small 16K blocks.

Recycle

When a tape is full, HSM must continually read the valid data from that tape volume and write it to a new tape.

HSM inventory

Reorgs, audits, and backups of the HSM inventory via the OCDS.

Transparent cloud tiering resolves these inefficiencies by moving the data directly from the DS8000 to the cloud object storage. This process eliminates the movement of data through the host, dual data movement, and the small 16K block size requirement. This process also eliminates recycle processing and the OCDS.

Transparent cloud tiering translates into significant savings in CPU utilization within z/OS, specifically when you are using both DFSMSHsm and transparent cloud tiering.

Modern enterprises adopted cloud storage to overcome the massive amount of data growth. The transparent cloud tiering system supports creating connections to cloud service providers to store data in private or public cloud storage. With transparent cloud tiering, administrators can move older data to cloud storage to free up capacity on the system. Point-in-time snapshots of data can be created on the system and then copied and stored on the cloud storage.

An external cloud service provider manages the cloud storage, which helps to reduce storage costs for the system. Before data can be copied to cloud storage, a connection to the cloud service provider must be created from the system. A cloud account is an object on the system that represents a connection to a cloud service provider by using a particular set of credentials. These credentials differ depending on the type of cloud service provider that is being specified. Most cloud service providers require the host name of the cloud service provider and an associated password, and some cloud service providers also require certificates to authenticate users of the cloud storage.

Public clouds use certificates that are signed by well-known certificate authorities. Private cloud service providers can use either self-signed certificate or a certificate that is signed by a trusted certificate authority. These credentials are defined on the cloud service provider and passed to the system through the administrators of the cloud service provider. A cloud account defines whether the system can successfully communicate and authenticate with the cloud service provider by using the account credentials. If the system is authenticated, it can then access cloud storage to either copy data to the cloud storage or restore data that is copied to cloud storage back to the system. The system supports one cloud account to a single cloud service provider. Migration between providers is not supported.

Client-side encryption for transparent cloud tiering ensures that data is encrypted before it is transferred to cloud storage. The data remains encrypted in cloud storage and is decrypted after it is transferred back to the storage system. You can use client-side encryption for transparent cloud tiering to download and decrypt data on any DS8000 storage system that uses the same set of key servers as the system that first encrypted the data.

Notes:

- Client-side encryption for transparent cloud tiering requires IBM Security Guardium Key Lifecycle Manager v3.0.0.2 or higher. For more information, see the [IBM Security Guardium Key Lifecycle Manager online product documentation \(www.ibm.com/docs/en/sgklm\)](http://www.ibm.com/docs/en/sgklm).
- Transparent cloud tiering supports the Key Management Interoperability Protocol (KMIP) only.

Cloud object storage is inherently multi-tenant, which allows multiple users to store data on the device, segregated from the other users. Each cloud service provider divides cloud storage into segments for each client that uses the cloud storage. These objects store only data specific to that client. Within the segment that is controlled by the user's name, DFSMSHsm and its inventory system controls the creation and segregation of containers that it uses to store the client data objects.

The storage system supports the OpenStack Swift and Amazon S3 APIs. The storage system also supports the IBM TS7700 as an object storage target and the following cloud service providers:

- Amazon S3
- IBM Cloud® Object Storage
- OpenStack Swift Based Private Cloud

Dynamic volume expansion

Dynamic volume expansion is the capability to increase provisioned capacity up to a maximum size while volumes are online to a host and not in a Copy Services relationship.

Dynamic volume expansion increases the capacity of open systems, IBM i, and IBM Z volumes, while the volume remains connected to a host system. This capability simplifies data growth by providing volume expansion without taking volumes offline.

Some operating systems do not support a change in volume size. Therefore, a host action is required to detect the change after the provisioned capacity is increased.

The following volume sizes are the maximum that are supported for each storage type.

- Open systems FB volumes: 16 TB
- IBM i variable size volumes
- IBM Z CKD volume types 3390 model 9 and custom: 65520 cylinders
- IBM Z CKD volume type 3390 model 3: 3339 cylinders
- IBM Z CKD volume types 3390 model A: 1,182,006 cylinders

Note: Volumes cannot be in Copy Services relationships (point-in-time copy, FlashCopy SE, Metro Mirror, Global Mirror, Metro/Global Mirror, and z/OS Global Mirror) during expansion.

Count key data and fixed block volume deletion prevention

By default, DS8000 attempts to prevent volumes that are online and in use from being deleted. The DS CLI and DS Storage Manager provides an option to force the deletion of count key data (CKD) and fixed block (FB) volumes that are in use.

For CKD volumes, *in use* means that the volumes are participating in a Copy Services relationship or are in a path group. For FB volumes, *in use* means that the volumes are participating in a Copy Services relationship or there is I/O access to the volume in the last five minutes. With Safeguarded Copy, *in use* means that the volumes have data saved in the backup repository.

If you specify the **-safe** option when you delete an FB volume, the system determines whether the volumes are assigned to non-default volume groups. If the volumes are assigned to a non-default (user-defined) volume group, the volumes are not deleted.

If you specify the **-force** option when you delete a volume, the storage system deletes volumes regardless of whether the volumes are in use. However, an *in use* volume that has Safeguarded Copy space cannot be deleted with the **-force** option.

Thin provisioning

Thin provisioning defines logical volume sizes that are larger than the usable capacity installed on the system. The volume allocates capacity on an as-needed basis as a result of host-write actions.

The thin provisioning feature enables the creation of extent space efficient logical volumes. Extent space efficient volumes are supported for FB and CKD volumes and are supported for all Copy Services functionality, including FlashCopy targets where they provide a space efficient FlashCopy capability.

Releasing space on CKD volumes that use thin provisioning

On an IBM Z® host, the DFSMSdss SPACEREL utility can release space from thin provisioned CKD volumes. The behavior depends on the Copy Services relationships that exist on the volume at the time the space release command is received.

Copy Services type	State	Space release allowed	Space release behavior
Metro Mirror	Duplex	Yes	Space is released on the primary and secondary. If the secondary copy is the primary copy of another Global Copy or Global Mirror relationship, space is also released on secondary copies of that relationship.
	Pending	Yes	Space is released on the primary and secondary. If the secondary copy is the primary copy of another Global Copy or Global Mirror relationship, space is also released on secondary copies of that relationship.
	Suspended	Yes	Space is released on the primary.

<i>Table 13. Space Release support for Copy Services volumes (continued)</i>			
Copy Services type	State	Space release allowed	Space release behavior
Global Mirror	Pending	Yes	Space is released on the primary copy after a new consistency group is formed. Space is released on the secondary copy after the next consistency group is formed and a FlashCopy commit is performed. If the secondary copy is the primary copy of another Global Mirror or Global Copy relationship, space is also released on secondary copies of that relationship.
	Suspended	Yes	Space is released on the primary.
Global Copy	Pending	Yes	Space is released on the primary and secondary copies. If the secondary copy is the primary copy of another Global Copy relationship, space is also released on secondary copies of that relationship.
	Suspended	Yes	Space is released on the primary.
z/OS Global Mirror	Primary	No	n/a
FlashCopy	Source	No	n/a
	Target	No	n/a
Safeguarded Copy	Source	Yes	Space is released when the Safeguarded backups prior to the space release command have been rolled off.
Safeguarded Recovery	Source	No	n/a
	Target	No	n/a

Space is released on Copy Services target volumes when these relationships are created or deleted:

- Space is released on FlashCopy targets when the FlashCopy is established or withdrawn.
- Space is released on Metro Mirror, Global Copy, and Global Mirror targets when the initial copy is performed.

Space is also released on a regular basis for Global Mirror FlashCopy targets as part of the consistency group formation process. To pace this process and avoid excessive release and reallocation, this is controlled by an internal algorithm, rather than releasing space every time a FlashCopy is performed.

Extent Space Efficient (ESE) capacity controls for thin provisioning

Use of thin provisioning can affect the amount of storage capacity that you choose to order. ESE capacity controls allow you to allocate storage appropriately.

With the mixture of thin-provisioned (ESE) and fully-provisioned (non-ESE) volumes in an extent pool, a method is needed to dedicate some of the extent-pool storage capacity for ESE user data usage, as well as limit the ESE user data usage within the extent pool. Another thing that is needed is the ability to detect when the available storage space within the extent pool for ESE volumes is running out of space.

Thin-provisioning capacity controls provide extent pool attributes to limit the maximum extent pool storage available for ESE user data usage, and to guarantee a proportion of the extent pool storage to be available for ESE user data usage.

An SNMP trap that is associated with the thin-provisioning capacity controls notifies you when the ESE extent usage in the pool exceeds an ESE extent threshold set by you. You are also notified when the extent pool is out of storage available for ESE user data usage.

Thin-provisioning capacity controls include the following attributes:

ESE Extent Threshold

The minimum threshold percentage of the real extents available. When the percentage of the currently available real extents is less than this minimum percentage, notifications are reported. This parameter is only applicable if an ESE repository has been defined for the pool using the DS CLI **mkextpool** and **chextpool** commands. Use these commands to set a threshold at which an alert is generated indicating that the space allocated to the ESE devices is running low.

ESE Extent Status

One of the three following values:

- 0: the percent of the available thin-provisioning capacity is greater than the ESE extent threshold
- 1: the percent of the available thin-provisioning capacity is greater than zero but less than or equal to the ESE extent threshold
- 10: the percent of the available thin-provisioning capacity is zero

Note: When the size of the extent pool remains fixed or is only increased, the usable capacity remains greater than or equal to the used capacity. However, a reduction in the size of the extent pool can cause the usable capacity to become less than the used capacity in some cases.

For example, if the user requests that one of the ranks in an extent pool be depopulated, the data on that rank are moved to the remaining ranks in the pool causing the rank to become not allocated and removed from the pool. The user is advised to inspect the limits and threshold on the extent pool following any changes to the size of the extent pool to ensure that the specified values are still consistent with the user's intentions.

IBM Easy Tier

Easy Tier can greatly increase the performance of your system by ensuring frequently accessed data is put on faster storage. Its capabilities include manual provisioned capacity rebalance, auto performance rebalancing in both single-tier and multiple-tier pools, hot spot management, rank depopulation, manual volume migration, and thin provisioning support (ESE volumes only). Easy Tier determines the appropriate tier of storage that is based on data access requirements and then automatically and non-disruptively moves data, at the subvolume or sub-LUN level, to the appropriate tier in the storage system.

Use Easy Tier to dynamically move your data to the appropriate drive tier in your storage system with its automatic performance monitoring algorithms. You can use this feature to increase the efficiency of your flash drives and the efficiency of all the tiers in your storage system.

You can use the features of Easy Tier between three tiers of storage within a DS8000.

Easy Tier features help you to effectively manage your system health, storage performance, and storage capacity automatically. Easy Tier uses system configuration and workload analysis with warm demotion to achieve effective overall system health. Simultaneously, data promotion and auto-rebalancing address performance while cold demotion works to address capacity.

Easy Tier data in memory persists in local storage or storage in the peer server, ensuring the Easy Tier configurations are available at failover, cold start, or Easy Tier restart.

With Easy Tier Application, you can also assign logical volumes to a specific tier. This feature can be useful when certain data is accessed infrequently, but needs to always be highly available.

Easy Tier Application is enhanced by two related functions:

- Easy Tier Application for IBM Z provides comprehensive data-placement management policy support from application to storage.

- Easy Tier application controls over workload learning and data migration provides a granular pool-level and volume-level Easy Tier control as well as volume-level tier assignment where a volume can be assigned to a tier.

The Easy Tier Heat Map Transfer utility replicates Easy Tier primary storage workload learning results to secondary storage sites, synchronizing performance characteristics across all storage systems. In the event of data recovery, storage system performance is not sacrificed.

Easy Tier helps manage thin provisioned volumes. If the initial allocation of new extents is set to the highest performance tier in the pool, as thin provisioned volumes grow, Easy Tier automatically detects if the data placed in these new extents should remain in the higher performance tier, or if they should be demoted to a capacity tier.

An additional feature provides the capability for you to use Easy Tier manual processing for thin provisioning. Rank depopulation is supported on ranks with ESE volumes allocated (extent space-efficient) or auxiliary volumes.

Use the capabilities of Easy Tier to support:

Drive classes

The following drive classes are available, in order from highest to lowest performance. A pool can contain up to three drive classes.

Flash Tier 0 drives

The highest performance drives, which provide high I/O throughput and low latency.

Flash Tier 1 drives

The first tier of high capacity drives.

Flash Tier 2 drives

The second tier of high capacity drives.

Three tiers

Using three tiers (each representing a separate drive class) and efficient algorithms improves system performance and cost effectiveness.

You can select from four drive classes to create up to three tiers. The drives within a tier must be single-tier.

The following table lists the possible tier assignments for the drive classes. The tiers are listed according to the following values:

0

Hot data tier, which contain the most active data. This tier can also serve as the home tier for new data allocations.

1

Mid-data tier, which can be combined with one or both of the other tiers and will contain data not moved to either of these tiers. This is by default the home tier for new data allocations.

2

Cold data tier, which contains the least active data.

Drive classes	Drive class combinations			
	Flash Tier 0	Flash Tier 0 + Flash Tier 1	Flash Tier 0 + Flash Tier 2	Flash Tier 0 + Flash Tier 1 + Flash Tier 2
Flash Tier 0	0	0	0	0
Flash Tier 1		1		1
Flash Tier 2			1	2

Table 15. Drive class combinations and tiers for systems with Flash Tier 1 drives as the highest performance drive class

Drive classes	Drive class combinations	
	Flash Tier 1	Flash Tier 1 + Flash Tier 2
Flash Tier 1	0	0
Flash Tier 2		1

Cold demotion

Cold data (or extents) stored on a higher-performance tier is demoted to a more appropriate tier. Cold demotion will occur with both two-tier and three-tier pools. Sequential bandwidth is moved to the lower tier to increase the efficient use of your tiers.

Warm demotion

Active data that has larger bandwidth is demoted to the next lowest tier. Warm demotion is triggered whenever the higher tier is over its bandwidth capacity. Selected warm extents are demoted to allow the higher tier to operate at its optimal load. Warm demotes do not follow a predetermined schedule.

Warm promotion

Active data that has higher IOPS is promoted to the next highest tier. Warm promotion is triggered whenever the lower tier is over its IOPS capacity. Selected warm extents are promoted to allow the lower tier to operate at its optimal load. Warm promotes do not follow a predetermined schedule.

Manual volume or pool rebalance

Volume rebalancing relocates the smallest number of extents of a volume and restripes those extents on all available ranks of the extent pool.

Auto-rebalancing

Automatically balances the workload of the same storage tier to improve system performance and resource use. Auto-rebalancing will occur in both single-tier and multiple-tier pools.

Rank depopulations

Allows ranks that have extents (data) allocated to them to be unassigned from an extent pool by using extent migration to move extents from the specified ranks to other ranks within the pool.

Easy Tier provides a performance monitoring capability, regardless of whether the Easy Tier feature is activated. Easy Tier uses the monitoring process to determine what data to move and when to move it when you use automatic mode. You can enable monitoring independently (with or without the Easy Tier feature activated) for information about the behavior and benefits that can be expected if automatic mode were enabled.

Data from the monitoring process is included in a summary report that you can download to your local system.

VMware vStorage API for Array Integration support

The storage system provides support for the VMware vStorage API for Array Integration (VAAI).

The VAAI API offloads storage processing functions from the server to the storage system, reducing the workload on the host server hardware for improved performance on both the network and host servers.

The following operations are supported:

Atomic test and set or VMware hardware-assisted locking

The hardware-assisted locking feature uses the VMware Compare and Write command for reading and writing the volume's metadata within a single operation. With the Compare and Write command, the storage system provides a faster mechanism that is displayed to the volume as an atomic action that does not require locking the entire volume.

The Compare and Write command is supported on all open systems fixed block volumes, including Metro Mirror and Global Mirror primary volumes and FlashCopy source and target volumes.

XCOPY or Full Copy

The XCOPY (or extended copy) command copies multiple files from one directory to another or across a network.

Full Copy copies data from one storage array to another without writing to the VMware ESX Server (VMware vStorage API).

The following restrictions apply to XCOPY:

- XCOPY is not supported on Extent Space Efficient (ESE) volumes
- XCOPY is not supported on volumes greater than 2 TB
- The target of an XCOPY cannot be a Metro Mirror or Global Mirror primary volume
- The Copy Services license is required

Block Zero (Write Same)

The SCSI Write Same command is supported on all volumes. This command efficiently writes each block, faster than standard SCSI write commands, and is optimized for network bandwidth usage.

IBM vCenter plug-in for ESX 4.x

The IBM vCenter plug-in for ESX 4.x provides support for the VAAI interfaces on ESX 4.x.

VMware vCenter Site Recovery Manager 5.0

VMware vCenter Site Recovery Manager (SRM) provides methods to simplify and automate disaster recovery processes. IBM Site Replication Adapter (SRA) communicates between SRM and the storage replication interface. SRA support for SRM 5.0 includes the new features for planned migration, reprotection, and failback. The supported Copy Services are Metro Mirror, Global Mirror, Metro-Global Mirror, and FlashCopy.

The IBM Storage Management Console plug-in enables VMware administrators to manage their systems from within the VMware management environment. This plug-in provides an integrated view of IBM storage to VMware virtualize datastores that are required by VMware administrators.

Performance for IBM Z

The storage system supports the following IBM performance enhancements for IBM Z environments.

- Parallel Access Volumes (PAVs)
- Multiple allegiance
- z/OS Distributed Data Backup
- z/HPF extended distance capability
- zHyperLink

Parallel Access Volumes

A PAV capability represents a significant performance improvement by the storage unit over traditional I/O processing. With PAVs, your system can access a single volume from a single host with multiple concurrent requests.

You must configure both your storage unit and operating system to use PAVs. You can use the logical configuration definition to define PAV-bases, PAV-aliases, and their relationship in the storage unit hardware. This unit address relationship creates a single logical volume, allowing concurrent I/O operations.

Static PAV associates the PAV-base address and its PAV aliases in a predefined and fixed method. That is, the PAV-aliases of a PAV-base address remain unchanged. Dynamic PAV, on the other hand, dynamically associates the PAV-base address and its PAV aliases. The device number types (PAV-alias or PAV-base) must match the unit address types as defined in the storage unit hardware.

You can further enhance PAV by adding the IBM HyperPAV feature. IBM HyperPAV associates the volumes with either an alias address or a specified base logical volume number. When a host system requests IBM HyperPAV processing and the processing is enabled, aliases on the logical subsystem are placed in an

IBM HyperPAV alias access state on all logical paths with a specific path group ID. IBM HyperPAV is only supported on FICON channel paths.

PAV can improve the performance of large volumes. You get better performance with one base and two aliases on a 3390 Model 9 than from three 3390 Model 3 volumes with no PAV support. With one base, it also reduces storage management costs that are associated with maintaining large numbers of volumes. The alias provides an alternate path to the base device. For example, a 3380 or a 3390 with one alias has only one device to write to, but can use two paths.

The storage unit supports concurrent or parallel data transfer operations to or from the same volume from the same system or system image for IBM Z or S/390® hosts. PAV software support enables multiple users and jobs to simultaneously access a logical volume. Read and write operations can be accessed simultaneously to different domains. (The domain of an I/O operation is the specified extents to which the I/O operation applies.)

Multiple allegiance

With multiple allegiance, the storage unit can run concurrent, multiple requests from multiple hosts.

Traditionally, IBM storage subsystems allow only one channel program to be active to a disk volume at a time. This means that, after the subsystem accepts an I/O request for a particular unit address, this unit address appears "busy" to subsequent I/O requests. This single allegiance capability ensures that additional requesting channel programs cannot alter data that is already being accessed.

By contrast, the storage unit is capable of multiple allegiance (or the concurrent execution of multiple requests from multiple hosts). That is, the storage unit can queue and concurrently run multiple requests for the same unit address, if no extent conflict occurs. A conflict refers to either the inclusion of a Reserve request by a channel program or a Write request to an extent that is in use.

z/OS Distributed Data Backup

z/OS Distributed Data Backup (zDDB) allows hosts, which are attached through a FICON interface, to access data on fixed block (FB) volumes through a device address on FICON interfaces.

If the zDDB LIC feature key is installed and enabled and a volume group type specifies either FICON interfaces, this volume group has implicit access to all FB logical volumes that are configured in addition to all CKD volumes specified in the volume group. In addition, this optional feature enables data backup of open systems from distributed server platforms through a IBM Z host. The feature helps you manage multiple data protection environments and consolidate those into one environment that is managed by IBM Z. For more information, see [“z/OS Distributed Data Backup” on page 103](#).

z/HPF extended distance

z/HPF extended distance reduces the impact that is associated with supported commands on current adapter hardware, improving FICON throughput on the I/O ports. The storage system also supports the new zHPF I/O commands for multitrack I/O operations.

zHyperLink

zHyperLink is a short distance link technology that is designed for up to 10 times lower latency than zHPF. It can speed up transaction processing and improve active log throughput. zHyperLink is intended to complement FICON technology to accelerate I/O requests that are typically used for transaction processing.

Copy Services

Copy Services functions can help you implement storage solutions to keep your business running 24 hours a day, 7 days a week. Copy Services include a set of disaster recovery, data migration, and data duplication functions.

The storage system supports Copy Service functions that contribute to the protection of your data. .

Notes:

- If you are creating paths between an older release of the DS8000 (Release 5.1 or earlier), which supports only 4-port host adapters, and a newer release of the DS8000 (Release 6.0 or later), which supports 8-port host adapters, the paths connect only to the lower four ports on the newer storage system.
- If you are creating paths from a model 993 4-port host adapter to a previous release DS8000 (Release 6.0 or later), which supports 8-port host adapters, you can only connect the lower four ports of the 8-port host adapter.
- The maximum number of FlashCopy relationships that are allowed on a volume is 65534. If that number is exceeded, the FlashCopy operation fails.
- The size limit for volumes or extents in a Copy Service relationship is 2 TB.
- Thin provisioning functions in open-system environments are supported for the following Copy Services functions:
 - FlashCopy relationships
 - Global Mirror relationships if the Global Copy A and B volumes are Extent Space Efficient (ESE) volumes. The FlashCopy target volume (Volume C) in the Global Mirror relationship can be an ESE volume or standard volume.
- PPRC supports any intermix of T10-protected or standard volumes. FlashCopy does not support intermix.
- PPRC supports copying from standard volumes to ESE volumes, or ESE volumes to Standard volumes, to allow migration with PPRC failover when both source and target volumes are on a DS8000 version 8.2 or higher.

The following Copy Services functions are available as optional features:

- Point-in-time copy, which includes IBM FlashCopy.

The FlashCopy function allows you to make point-in-time, full volume copies of data so that the copies are immediately available for read or write access. In IBM Z environments, you can also use the FlashCopy function to perform data set level copies of your data.
- Remote mirror and copy, which includes the following functions:
 - Metro Mirror

Metro Mirror provides real-time mirroring of logical volumes between two storage system that can be located up to 300 km from each other. It is a synchronous copy solution where write operations are completed on both copies (local and remote site) before they are considered to be done.
 - Global Copy

Global Copy is a nonsynchronous long-distance copy function where incremental updates are sent from the local to the remote site on a periodic basis.
 - Global Mirror

Global Mirror is a long-distance remote copy function across two sites by using asynchronous technology. Global Mirror processing is designed to provide support for unlimited distance between the local and remote sites, with the distance typically limited only by the capabilities of the network and the channel extension technology.
 - Metro/Global Mirror (a combination of Metro Mirror and Global Mirror)

Metro/Global Mirror is a three-site remote copy solution. It uses synchronous replication to mirror data between a local site and an intermediate site, and asynchronous replication to mirror data from an intermediate site to a remote site.
 - Multiple Target PPRC

Multiple Target PPRC builds and extends the capabilities of Metro Mirror and Global Mirror. It allows data to be mirrored from a single primary site to two secondary sites simultaneously. You can define

any of the sites as the primary site and then run Metro Mirror replication from the primary site to either of the other sites individually or both sites simultaneously.

- Remote mirror and copy for IBM Z environments, which includes z/OS Global Mirror.

Note: When FlashCopy is used on FB (open) volumes, the source and the target volumes must have the same protection type of either T10 DIF or standard.

The point-in-time and remote mirror and copy features are supported across various IBM server environments such as IBM i, System p, and IBM Z, as well as servers from Oracle and Hewlett-Packard.

You can manage these functions through a command-line interface that is called the DS CLI.

Point-in-time copy (FlashCopy)

You can use the FlashCopy function to make point-in-time, full volume copies of data, with the copies immediately available for read or write access. In IBM Z environments, you can also use the FlashCopy function to perform data set level copies of your data. You can use the copy with standard backup tools that are available in your environment to create backup copies on tape.

FlashCopy is an optional function.

The FlashCopy function creates a copy of a source volume on the target volume. This copy is called a point-in-time copy. When you initiate a FlashCopy operation, a FlashCopy relationship is created between a source volume and target volume. A FlashCopy relationship is a *mapping* of the FlashCopy source volume and a FlashCopy target volume. This mapping allows a point-in-time copy of that source volume to be copied to the associated target volume. The FlashCopy relationship exists between the volume pair in either case:

- From the time that you initiate a FlashCopy operation until the storage system copies all data from the source volume to the target volume.
- Until you explicitly delete the FlashCopy relationship if it was created as a persistent FlashCopy relationship.

One of the main benefits of the FlashCopy function is that the point-in-time copy is immediately available for creating a backup of production data. The target volume is available for read and write processing so it can be used for testing or backup purposes. Data is physically copied from the source volume to the target volume by using a background process. (A FlashCopy operation without a background copy is also possible, which allows only data modified on the source to be copied to the target volume.) The amount of time that it takes to complete the background copy depends on the following criteria:

- The amount of data to be copied
- The number of background copy processes that are occurring
- The other activities that are occurring on the storage systems

The FlashCopy function supports the following copy options:

Consistency groups

Creates a consistent point-in-time copy of multiple volumes, with negligible host impact. You can enable FlashCopy consistency groups from the DS CLI.

Change recording

Activates the change recording function on the volume pair that is participating in a FlashCopy relationship. This function enables a subsequent refresh to the target volume.

Establish FlashCopy on existing Metro Mirror source

Establish a FlashCopy relationship, where the target volume is also the source of an existing remote mirror and copy source volume. This allows you to create full or incremental point-in-time copies at a local site and then use remote mirroring commands to copy the data to the remote site.

Fast reverse

Reverses the FlashCopy relationship without waiting for the finish of the background copy of the previous FlashCopy. This option applies to the Global Mirror mode.

Inhibit writes to target

Ensures that write operations are inhibited on the target volume until a refresh FlashCopy operation is complete.

Multiple Incremental FlashCopy

Allows a source volume to establish incremental flash copies to a maximum of 12 targets.

Multiple Relationship FlashCopy

Allows a source volume to have multiple (up to 12) target volumes at the same time.

Persistent FlashCopy

Allows the FlashCopy relationship to remain even after the FlashCopy operation completes. You must explicitly delete the relationship.

Refresh target volume

Refresh a FlashCopy relationship, without recopying all tracks from the source volume to the target volume.

Resynchronizing FlashCopy volume pairs

Update an initial point-in-time copy of a source volume without having to recopy your entire volume.

Reverse restore

Reverses the FlashCopy relationship and copies data from the target volume to the source volume.

Reset SCSI reservation on target volume

If there is a SCSI reservation on the target volume, the reservation is released when the FlashCopy relationship is established. If this option is not specified and a SCSI reservation exists on the target volume, the FlashCopy operation fails.

Remote Pair FlashCopy

Figure 6 on page 73 illustrates how Remote Pair FlashCopy works. If Remote Pair FlashCopy is used to copy data from Local A to Local B, an equivalent operation is also performed from Remote A to Remote B. FlashCopy can be performed as described for a Full Volume FlashCopy, Incremental FlashCopy, and Dataset Level FlashCopy.

The Remote Pair FlashCopy function prevents the Metro Mirror relationship from changing states and the resulting momentary period where Remote A is out of synchronization with Remote B. This feature provides a solution for data replication, data migration, remote copy, and disaster recovery tasks.

Without Remote Pair FlashCopy, when you established a FlashCopy relationship from Local A to Local B, by using a Metro Mirror primary volume as the target of that FlashCopy relationship, the corresponding Metro Mirror volume pair went from "full duplex" state to "duplex pending" state if the FlashCopy data was being transferred to the Local B. The time that it took to complete the copy of the FlashCopy data until all Metro Mirror volumes were synchronous again, depended on the amount of data transferred. During this time, the Local B would be inconsistent if a disaster were to have occurred.

Note: Previously, if you created a FlashCopy relationship with the **Preserve Mirror, Required** option, by using a Metro Mirror primary volume as the target of that FlashCopy relationship, and if the status of the Metro Mirror volume pair was not in a "full duplex" state, the FlashCopy relationship failed. That restriction is now removed. The Remote Pair FlashCopy relationship completes successfully with the "Preserve Mirror, Required" option, even if the status of the Metro Mirror volume pair is either in a suspended or duplex pending state.

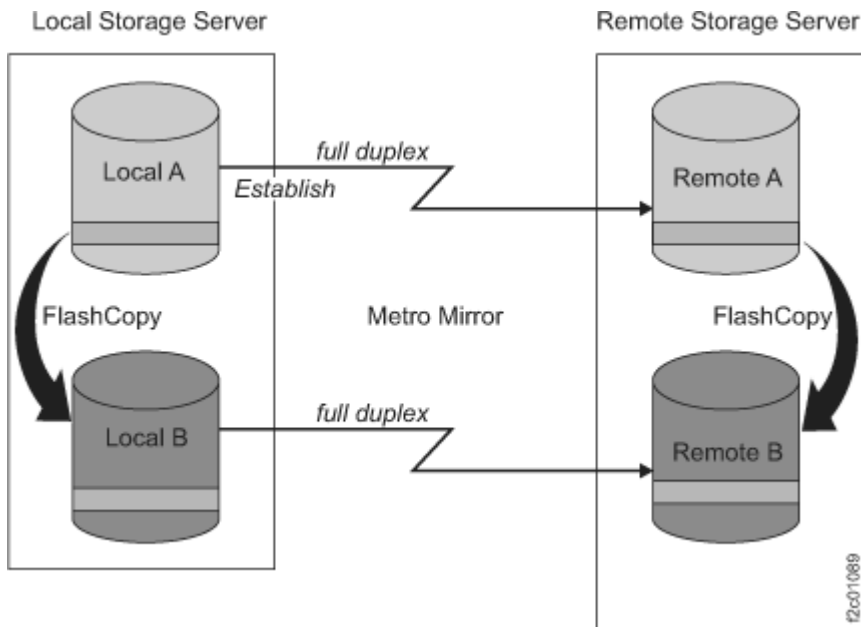

Figure 6. Remote Pair FlashCopy

Note: The storage system supports Incremental FlashCopy and Metro Global Mirror Incremental Resync on the same volume.

Safeguarded Copy

The Safeguarded Copy feature creates safeguarded backups that are not accessible by the host system and protects these backups from corruption that can occur in the production environment. You can define a Safeguarded Copy schedule to create multiple backups on a regular basis, such as hourly or daily. You can also restore a backup to the source volume or to a different volume. A backup contains the same metadata as the safeguarded source volume.

Safeguarded Copy can create backups with more frequency and capacity in comparison to FlashCopy volumes. The creation of safeguarded backups also impacts performance less than the multiple target volumes that are created by FlashCopy.

With backups that are outside of the production environment, you can use the backups to restore your environment back to a specified point in time. You can also extract and restore specific data from the backup or use the backup to diagnose production issues.

You cannot delete a safeguarded source volume before the safeguarded backups are deleted. The maximum size of a backup is 16 TB.

Copy Services Manager (available on the Hardware Management Console) is required to facilitate the use and management of Safeguarded Copy functions.

Remote mirror and copy

The remote mirror and copy feature is a flexible data mirroring technology that allows replication between a source volume and a target volume on one or two disk storage systems. You can also issue remote mirror and copy operations to a group of source volumes on one logical subsystem (LSS) and a group of target volumes on another LSS. (An LSS is a logical grouping of up to 256 logical volumes for which the volumes must have the same disk format, either count key data or fixed block.)

Remote mirror and copy is an optional feature that provides data backup and disaster recovery.

Note: You must use Fibre Channel host adapters with remote mirror and copy functions. To see a current list of environments, configurations, networks, and products that support remote mirror and copy functions, click **Interoperability Matrix** at the following location [IBM System Storage Interoperation Center \(SSIC\) website\(www-03.ibm.com/systems/support/storage/ssic/interoperability.was\)](http://www-03.ibm.com/systems/support/storage/ssic/interoperability.was).

The remote mirror and copy feature provides synchronous (Metro Mirror) and asynchronous (Global Copy) data mirroring. The main difference is that the Global Copy feature can operate at long distances, even continental distances, with minimal impact on applications. Distance is limited only by the network and channel extenders technology capabilities. The maximum supported distance for Metro Mirror is 300 km.

With Metro Mirror, application write performance depends on the available bandwidth. Global Copy enables better use of available bandwidth capacity to allow you to include more of your data to be protected.

The enhancement to Global Copy is Global Mirror, which uses Global Copy and the benefits of FlashCopy to form consistency groups. (A consistency group is a set of volumes that contain consistent and current data to provide a true data backup at a remote site.) Global Mirror uses a master storage system (along with optional subordinate storage systems) to internally, without external automation software, manage data consistency across volumes by using consistency groups.

Consistency groups can also be created by using the freeze and run functions of Metro Mirror. The freeze and run functions, when used with external automation software, provide data consistency for multiple Metro Mirror volume pairs.

The following sections describe the remote mirror and copy functions.

Synchronous mirroring (Metro Mirror)

Provides real-time mirroring of logical volumes (a source and a target) between two storage systems that can be located up to 300 km from each other. With Metro Mirror copying, the source and target volumes can be on the same storage system or on separate storage systems. You can locate the storage system at another site, some distance away.

Metro Mirror is a synchronous copy feature where write operations are completed on both copies (local and remote site) before they are considered to be complete. Synchronous mirroring means that a storage server constantly updates a secondary copy of a volume to match changes that are made to a source volume.

The advantage of synchronous mirroring is that there is minimal host impact for performing the copy. The disadvantage is that since the copy operation is synchronous, there can be an impact to application performance because the application I/O operation is not acknowledged as complete until the write to the target volume is also complete. The longer the distance between primary and secondary storage systems, the greater this impact to application I/O, and therefore, application performance.

Asynchronous mirroring (Global Copy)

Copies data nonsynchronously and over longer distances than is possible with the Metro Mirror feature. When operating in Global Copy mode, the source volume sends a periodic, incremental copy of updated tracks to the target volume instead of a constant stream of updates. This function causes less impact to application writes for source volumes and less demand for bandwidth resources. It allows for a more flexible use of the available bandwidth.

The updates are tracked and periodically copied to the target volumes. As a consequence, there is no guarantee that data is transferred in the same sequence that was applied to the source volume.

To get a consistent copy of your data at your remote site, periodically switch from Global Copy to Metro Mirror mode, then either stop the application I/O or freeze data to the source volumes by using a manual process with freeze and run commands. The freeze and run functions can be used with external automation software such as Geographically Dispersed Parallel Sysplex (GDPS[®]), which is available for IBM Z environments, to ensure data consistency to multiple Metro Mirror volume pairs in a specified logical subsystem.

Common options for Metro Mirror/Global Mirror and Global Copy include the following modes:

Suspend and resume

If you schedule a planned outage to perform maintenance at your remote site, you can suspend Metro Mirror/Global Mirror or Global Copy processing on specific volume pairs during the duration of the outage. During this time, data is no longer copied to the target volumes. Because the primary storage system tracks all changed data on the source volume, you can resume operations later to synchronize the data between the volumes.

Copy out-of-synchronous data

You can specify that only data updated on the source volume while the volume pair was suspended is copied to its associated target volume.

Copy an entire volume or not copy the volume

You can copy an entire source volume to its associated target volume to guarantee that the source and target volume contain the same data. When you establish volume pairs and choose not to copy a volume, a relationship is established between the volumes but no data is sent from the source volume to the target volume. In this case, it is assumed that the volumes contain the same data and are consistent, so copying the entire volume is not necessary or required. Only new updates are copied from the source to target volumes.

Global Mirror

Provides a long-distance remote copy across two sites by using asynchronous technology. Global Mirror processing is most often associated with disaster recovery or disaster recovery testing. However, it can also be used for everyday processing and data migration.

Global Mirror integrates both the Global Copy and FlashCopy functions.

The Global Mirror function mirrors data between volume pairs of two storage systems over greater distances without affecting overall performance. It also provides application-consistent data at a recovery (or remote) site in a disaster at the local site. By creating a set of remote volumes every few seconds, the data at the remote site is maintained to be a point-in-time consistent copy of the data at the local site.

Global Mirror operations periodically start point-in-time FlashCopy operations at the recovery site, at regular intervals, without disrupting the I/O to the source volume, thus giving a continuous, near up-to-date data backup. By grouping many volumes into a session that is managed by the master storage system, you can copy multiple volumes to the recovery site simultaneously maintaining point-in-time consistency across those volumes. (A session contains a group of source volumes that are mirrored asynchronously to provide a consistent copy of data at the remote site. Sessions are associated with Global Mirror relationships and are defined with an identifier [session ID] that is unique across the enterprise. The ID identifies the group of volumes in a session that are related and that can participate in the Global Mirror consistency group.)

Global Mirror supports up to 32 Global Mirror sessions per storage facility image. Previously, only one session was supported per storage facility image.

You can use multiple Global Mirror sessions to fail over only data assigned to one host or application instead of forcing you to fail over all data if one host or application fails. This process provides increased flexibility to control the scope of a failover operation and to assign different options and attributes to each session.

The DS CLI and DS Storage Manager display information about the sessions, including the copy state of the sessions.

Practice copying and consistency groups

To get a consistent copy of your data, you can pause Global Mirror on a consistency group boundary. Use the pause command with the secondary storage option. (For more information, see the DS CLI Commands reference.) After verifying that Global Mirror is paused on a consistency boundary (state is Paused with Consistency), the secondary storage system and the FlashCopy target storage system or device are consistent. You can then issue either a FlashCopy or Global Copy command to make a practice copy on another storage system or device. You can immediately resume Global Mirror, without the need to wait for the practice copy operation to finish. Global Mirror then starts forming consistency groups again. The entire pause and resume operation generally takes just a few seconds.

Metro/Global Mirror

Provides a three-site, long-distance disaster recovery replication that combines Metro Mirror with Global Mirror replication for both IBM Z and open systems data. Metro/Global Mirror uses synchronous replication to mirror data between a local site and an intermediate site, and asynchronous replication to mirror data from an intermediate site to a remote site.

In a three-site Metro/Global Mirror, if an outage occurs, a backup site is maintained regardless of which one of the sites is lost. Suppose that an outage occurs at the local site, Global Mirror continues to mirror updates between the intermediate and remote sites, maintaining the recovery capability at the remote site. If an outage occurs at the intermediate site, data at the local storage system is not affected. If an outage occurs at the remote site, data at the local and intermediate sites is not affected. Applications continue to run normally in either case.

With the incremental resynchronization function enabled on a Metro/Global Mirror configuration, if the intermediate site is lost, the local and remote sites can be connected, and only a subset of changed data is copied between the volumes at the two sites. This process reduces the amount of data needing to be copied from the local site to the remote site and the time it takes to do the copy.

Multiple Target PPRC

Provides an enhancement to disaster recovery solutions by allowing data to be mirrored from a single primary site to two secondary sites simultaneously. The function builds on and extends Metro Mirror and Global Mirror capabilities. Various interfaces and operating systems support the function. Disaster recovery scenarios depend on support from controlling software such as Geographically Dispersed Parallel Sysplex (GDPS) and IBM Copy Services Manager.

z/OS Global Mirror Multiple Reader (enhanced readers)

z/OS Global Mirror Multiple Reader provides multiple Storage Device Manager readers that allow improved throughput for remote mirroring configurations in IBM Z environments. z/OS Global Mirror Multiple Reader helps maintain constant data consistency between mirrored sites and promotes efficient recovery. This function is supported on the storage system running in a IBM Z environment with version 1.7 or later at no additional charge.

Interoperability with existing and previous generations of the DS8000 series

All of the remote mirroring solutions that are documented in the sections above use Fibre Channel as the communications link between the primary and secondary storage systems. The Fibre Channel ports that are used for remote mirror and copy can be configured as either a dedicated remote mirror link or as a shared port between remote mirroring and Fibre Channel Protocol (FCP) data traffic.

The remote mirror and copy solutions are optional capabilities and are compatible with previous generations of DS8000 series. They are available as follows:

- Metro Mirror indicator feature numbers 75xx and 0744 and corresponding DS8000 series function authorization (2396-LFA MM feature numbers 75xx)
- Global Mirror indicator feature numbers 75xx and 0746 and corresponding DS8000 series function authorization (2396-LFA GM feature numbers 75xx).

Global Copy is a non-synchronous long-distance copy option for data migration and backup.

Disaster recovery through Copy Services

Through Copy Services functions, you can prepare for a disaster by backing up, copying, and mirroring your data at local and remote sites.

Having a disaster recovery plan can ensure that critical data is recoverable at the time of a disaster. Because most disasters are unplanned, your disaster recovery plan must provide a way to recover your applications quickly, and more importantly, to access your data. Consistent data to the same point-in-time across all storage units is vital before you can recover your data at a backup (normally your remote) site.

Most users use a combination of remote mirror and copy and point-in-time copy (FlashCopy) features to form a comprehensive enterprise solution for disaster recovery. In an event of a planned event or unplanned disaster, you can use failover and failback modes as part of your recovery solution. Failover and failback modes can reduce the synchronization time of remote mirror and copy volumes after you switch between local (or production) and intermediate (or remote) sites during an outage. Although failover transmits no data, it changes the status of a device, and the status of the secondary volume changes to a suspended primary volume. The device that initiates the failback command determines the direction of the transmitted data.

Recovery procedures that include failover and failback modes use remote mirror and copy functions, such as Metro Mirror, Global Copy, Global Mirror, Metro/Global Mirror, Multiple Target PPRC, and FlashCopy.

Note: See the *IBM DS8000 Command-Line Interface User's Guide* for specific disaster recovery tasks.

Data consistency can be achieved through the following methods:

Manually using external software (without Global Mirror)

You can use Metro Mirror, Global Copy, and FlashCopy functions to create a consistent and restartable copy at your recovery site. These functions require a manual and periodic suspend operation at the local site. For instance, you can enter the **freeze** and **run** commands with external automated software. Then, you can initiate a FlashCopy function to make a consistent copy of the target volume for backup or recovery purposes. Automation software is not provided with the storage system; it must be supplied by the user.

Note: The **freeze** operation occurs at the same point-in-time across all links and all storage systems.

Automatically (with Global Mirror and FlashCopy)

You can automatically create a consistent and restartable copy at your intermediate or remote site with minimal or no interruption of applications. This automated process is available for two-site Global Mirror or three-site Metro / Global Mirror configurations. Global Mirror operations automate the process of continually forming consistency groups. It combines Global Copy and FlashCopy operations to provide consistent data at the remote site. A master storage unit (along with subordinate storage units) internally manages data consistency through consistency groups within a Global Mirror configuration. Consistency groups can be created many times per hour to increase the currency of data that is captured in the consistency groups at the remote site.

Note: A consistency group is a collection of session-grouped volumes across multiple storage systems. Consistency groups are managed together in a session during the creation of consistent copies of data. The formation of these consistency groups is coordinated by the master storage unit, which sends commands over remote mirror and copy links to its subordinate storage units.

If a disaster occurs at a local site with a two or three-site configuration, you can continue production on the remote (or intermediate) site. The consistent point-in-time data from the remote site consistency group enables recovery at the local site when it becomes operational.

Resource groups for Copy Services scope limiting

Resource groups are used to define a collection of resources and associate a set of policies relative to how the resources are configured and managed. You can define a network user account so that it has authority to manage a specific set of resources groups.

Copy Services scope limiting overview

Copy services scope limiting is the ability to specify policy-based limitations on Copy Services requests. With the combination of policy-based limitations and other inherent volume-addressing limitations, you can control which volumes can be in a Copy Services relationship, which network users or host LPARs issue Copy Services requests on which resources, and other Copy Services operations.

Use these capabilities to separate and protect volumes in a Copy Services relationship from each other. This can assist you with multitenancy support by assigning specific resources to specific tenants, limiting Copy Services relationships so that they exist only between resources within each tenant's scope of resources, and limiting a tenant's Copy Services operators to an "operator only" role.

When managing a single-tenant installation, the partitioning capability of resource groups can be used to isolate various subsets of an environment as if they were separate tenants. For example, to separate mainframes from distributed system servers, Windows from UNIX, or accounting departments from telemarketing.

Using resource groups to limit Copy Service operations

Figure 7 on page 78 illustrates one possible implementation of an exemplary environment that uses resource groups to limit Copy Services operations. Two tenants (Client A and Client B) are illustrated that are concurrently operating on shared hosts and storage systems.

Each tenant has its own assigned LPARs on these hosts and its own assigned volumes on the storage systems. For example, a user cannot copy a Client A volume to a Client B volume.

Resource groups are configured to ensure that one tenant cannot cause any Copy Services relationships to be initiated between its volumes and the volumes of another tenant. These controls must be set by an administrator as part of the configuration of the user accounts or access-settings for the storage system.

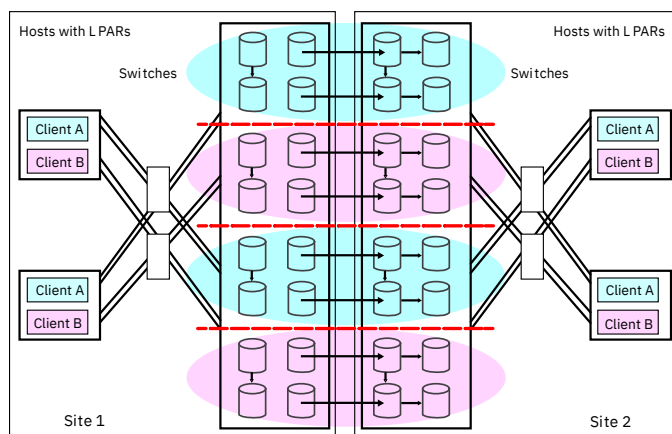

Figure 7. Implementation of multiple-client volume administration

Resource groups functions provide additional policy-based limitations to users or the DS8000 storage systems, which in conjunction with the inherent volume addressing limitations support secure partitioning of Copy Services resources between user-defined partitions. The process of specifying the appropriate limitations is completed by an administrator using resource groups functions.

Note: User and administrator roles for resource groups are the same user and administrator roles used for accessing your DS8000 storage system. For example, those roles include storage administrator, Copy Services operator, and physical operator.

The process of planning and designing the use of resource groups for Copy Services scope limiting can be complex. For more information on the rules and policies that must be considered in implementing resource groups, see topics about resource groups. For specific DS CLI commands used to implement resource groups, see the *IBM DS8000 Command-Line Interface User's Guide*.

Comparison of Copy Services features

The features of the Copy Services aid with planning for a disaster.

Table 16 on page 79 provides a brief summary of the characteristics of the Copy Services features that are available for the storage system.

Table 16. Comparison of features

Feature	Description	Advantages	Considerations
Multiple Target PPRC	Synchronous and asynchronous replication	Mirrors data from a single primary site to two secondary sites simultaneously.	Disaster recovery scenarios depend on support from controlling software such as Geographically Dispersed Parallel Sysplex (GDPS) and IBM Copy Services Manager
Metro/Global Mirror	Three-site, long distance disaster recovery replication	A backup site is maintained regardless of which one of the sites is lost.	Recovery point objective (RPO) might grow if bandwidth capability is exceeded.
Metro Mirror	Synchronous data copy at a distance	No data loss, rapid recovery time for distances up to 300 km.	Slight performance impact.
Global Copy	Continuous copy without data consistency	Nearly unlimited distance, suitable for data migration, only limited by network and channel extenders capabilities.	Copy is normally fuzzy but can be made consistent through synchronization.
Global Mirror	Asynchronous copy	Nearly unlimited distance, scalable, and low RPO. The RPO is the time needed to recover from a disaster; that is, the total system downtime.	RPO might grow when link bandwidth capability is exceeded.

Securing data

You can secure data with the encryption features that are supported by the storage system. The DS8A00 systems use AES-256 encryption.

Encryption technology has a number of considerations that are critical to understand to maintain the security and accessibility of encrypted data. For example, encryption must be enabled by feature code and configured to protect data in your environment. Encryption also requires access to at least two external key servers. However, with the local key manager enabled (feature 0405), the requirement for at least two external key servers does not apply.

It is important to understand how to manage IBM encrypted storage and comply with IBM encryption requirements. Failure to follow these requirements might cause a permanent encryption deadlock, which might result in the permanent loss of all key-server-managed encrypted data at all of your installations.

The storage system automatically tests access to the encryption keys every 8 hours and access to the key servers every 5 minutes. You can verify access to key servers manually, initiate key retrieval, and monitor the status of attempts to access the key server.

Chapter 4. Physical configuration

Physical configuration planning is your responsibility. Your technical support representative can help you to plan for the physical configuration and to select features.

This section includes the following information:

- Explanations for available features that can be added to the physical configuration of your system model
- Feature codes to use when you order each feature
- Configuration rules and guidelines

Configuration controls

Indicator features control the physical configuration of the storage system.

These indicator features are for administrative use only. The indicator features ensure that each storage system (the base frame plus any expansion frames) has a valid configuration. There is no charge for these features.

Your storage system can include the following indicators:

Expansion-frame position indicators

Expansion-frame position indicators flag models that are attached to expansion frames. They also flag the position of each expansion frame within the storage system. For example, a position 1 indicator flags the expansion frame as the first expansion frame within the storage system.

Administrative indicators

If applicable, models also include the following indicators:

- IBM / Openwave alliance
- IBM / EPIC attachment
- IBM systems, including System p and IBM Z
- Lenovo System x and BladeCenter
- IBM storage systems, including IBM System Storage ProtecTIER®, IBM Storwize® V7000, and IBM System Storage N series
- IBM SAN Volume Controller
- Linux
- VMware VAAI indicator
- Storage Appliance

Determining physical configuration features

You must consider several guidelines for determining and then ordering the features that you require to customize your storage system. Determine the feature codes for the optional features you select and use those feature codes to complete your configuration.

Procedure

1. Calculate your overall storage needs, including the licensed functions.

The Copy Services and z-Synergy Services licensed functions are based on usage requirements.

2. Determine the models of which your storage system is to be comprised.
3. For each model, determine the storage features that you need.

- a) Select the drive set feature codes and determine the amount of each feature code that you must order for each model.

- b) Select the storage enclosure feature codes and determine the amount that you must order to enclose the drive sets that you are ordering.
- c) Select the disk cable feature codes and determine the amount that you need of each.
4. Determine the I/O adapter features that you need for your storage system.
 - a) Select the flash RAID and host adapters feature codes to order, and choose a model to contain the adapters.
 - b) For each model chosen to contain adapters, determine the number of each I/O enclosure feature codes that you must order.
 - c) Select the cables that you require to support the adapters.
5. Based on the disk storage and adapters, determine the appropriate processor memory feature code that is needed.
6. Decide which power features that you must order to support each model.
7. Review the other features and determine which feature codes to order.

Storage features

You must select the storage features that you want on your storage system.

The storage features are separated into the following categories:

- Drive-set features and storage-enclosure features
- Enclosure filler features
- Device adapter features

Storage enclosures and drives

The IBM Storage DS8000 (10th Generation) supports various storage enclosures and drive options.

Feature codes for drive sets

Use these feature codes to order sets of encryption capable flash drives.

Feature code	Disk size	Drive type	Drives per set	Drive speed in RPM (K=1000)	Encryption capable drive	RAID support
1611	800 GB	2.5-in. Flash Tier 0 drives	16	N/A	Yes	6, 10
1612	1.6 TB	2.5-in. Flash Tier 0 drives	16	N/A	Yes	6, 10 ^{1, 2}
1613	3.2 TB	2.5-in. Flash Tier 0 drives	16	N/A	Yes	6, 10 ^{1, 2}
1622	1.92 TB	2.5-in. Flash Tier 2 drives	16	N/A	Yes	6, 10 ^{1, 2}
1623	3.84 TB	2.5-in. Flash Tier 1 drives	16	N/A	Yes	6, 10 ^{1, 2}
1624	7.68 TB	2.5-in. Flash Tier 2 drives	16	N/A	Yes	6, 10 ^{1, 2}
1625	15.36 TB	2.5-in. Flash Tier 2 drives	16	N/A	Yes	6, 10 ^{1, 2}

Table 17. Feature codes for flash-drive sets for High Performance Flash Enclosures Gen3 (continued)

Feature code	Disk size	Drive type	Drives per set	Drive speed in RPM (K=1000)	Encryption capable drive	RAID support
--------------	-----------	------------	----------------	-----------------------------	--------------------------	--------------

Note:

1. RAID 6 is the default RAID type for all drives larger than 1 TB.
2. Within a High Performance Flash Enclosure Gen2 pair, no intermix of high performance drives (Flash Tier 0) with high capacity drives (Flash Tier 1 or Flash Tier 2) is supported.

Feature codes for storage enclosures

Use these feature codes to identify the type of drive enclosures for your storage system.

Table 18. Feature codes for storage enclosures

Feature code	Description	Models
AACA	High Performance Flash Enclosure Gen3 Enclosure pair	all

Storage-enclosure fillers

Storage-enclosure fillers fill empty drive slots in the storage enclosures. The fillers ensure sufficient airflow across populated storage.

For High Performance Flash Enclosures Gen2, one filler feature provides a set of 16 fillers.

Feature codes for storage enclosure fillers

Use these feature codes to order filler sets for High Performance Flash Enclosures Gen3.

Table 19. Feature codes for storage enclosures

Feature code	Description
AACO	Flash enclosure filler set

Configuration rules for storage features

Use the following general configuration rules and ordering information to help you order storage features.

High Performance Flash Enclosures Gen3

Follow these configuration rules when you order storage features for storage systems with High Performance Flash Enclosures Gen2.

Flash drive sets

The High Performance Flash Enclosure Gen3 pair requires a minimum of one 16 flash-drive set.

Storage enclosure fillers

For the High Performance Flash Enclosures Gen3, one filler feature provides a set of 16 fillers. If only one flash-drive set is ordered, then two storage enclosure fillers are needed to fill the remaining 32 slots in the High Performance Flash Enclosures Gen3 pair. If two drive sets are ordered (32 drives), one filler set is require to fill the remaining 16 slots. Each drive slot in a High Performance Flash Enclosures Gen3 must have either a flash drive or a filler.

Raw and usable capacity

Use the following information to calculate the raw and usable capacity of a storage system.

To calculate the total raw capacity of a storage system, multiply each drive-set feature by its total raw capacity and sum the values. For the standard drive enclosures, a full drive-set feature consists of 16 identical disk drives with the same drive type, capacity, and speed. For High Performance Flash Enclosures Gen3, there are 16 identical flash drives.

The logical configuration of your storage affects the usable capacity of the drive set.

Specifically, usable capacities vary depending on the following configurations:

RAID type and spares

Drives in the DS8000 must be configured as RAID 6, or RAID 10 arrays before they can be used, and then spare drives are assigned. RAID 10 can offer better performance for selected applications, in particular, high random, write content applications in the open systems environment. RAID 6 increases data protection by adding an extra layer of parity over the RAID 5 implementation.

Data format

Arrays are logically configured and formatted as fixed block (FB) or count key data (CKD) ranks. Data that is accessed by open systems hosts or Linux on IBM Z that support Fibre Channel protocol must be logically configured as FB. Data that is accessed by IBM Z hosts with z/OS or z/VM[®] must be configured as CKD. Each RAID array is divided into equal-sized segments that are known as extents.

The storage administrator has the choice to create extent pools of different extent sizes. The supported extent sizes for FB volumes are 1 GB or 16 MB and for CKD volumes it is one 3390 Mod1, which is 1113 cylinders or 21 cylinders. An extent pool cannot have a mix of different extent sizes.

On prior models of DS8000 series, a fixed area on each rank was assigned to be used for volume metadata, which reduced the amount of space available for use by volumes. In the DS8A00 family, there is no fixed area for volume metadata, and this capacity is added to the space available for use. The metadata is allocated in the storage pool when volumes are created and is referred to as the pool overhead.

The amount of space that can be allocated by volumes is variable and depends on both the number of volumes and the logical capacity of these volumes. If thin provisioning is used, then the metadata is allocated for the entire volume when the volume is created, and not when extents are used, so over-provisioned environments have more metadata.

Metadata is allocated in units that are called metadata extents, which are 16 MB for FB data and 21 cylinders for CKD data. There are 64 metadata extents in each user extent for FB and 53 for CKD. The metadata space usage is as follows:

- Each volume takes one metadata extent.
- Ten extents (or part thereof) for the volume take one metadata extent.

For example, both a 3390-3 and a 3390-9 volume each take two metadata extents and a 128 GB FB volume takes 14 metadata extents.

Note: In a multiple tier pool volume, metadata is allocated on the upper tiers to provide maximum performance. A pool with 10% Flash/SSD or greater would have all of the volume metadata on this tier.

A simple way of estimating the maximum space that might be used by volume metadata is to use the following calculations:

```
FB Pool Overhead = (#volumes*2 + total volume extents / 10)/64 - rounded up  
to the nearest integer
```

```
CKD Pool Overhead = (#volumes*2 + total volume extents / 10)/53 - rounded up  
to the nearest integer
```

These calculations overestimate the space that is used by metadata by a small amount, but the precise details of each volume do not need to be known.

Examples:

- For an FB storage pool with 6,190 extents in which you expect to use thin provisioning and allocate up to 12,380 extents (2:1 overprovisioning) on 100 volumes, you would have a pool overhead of 23 extents -> $(100*2+12380/10)/64=22.46$.
- For a CKD storage pool with 6,190 extents in which you expect to allocate all the space on 700 volumes, then you would have a pool overhead of 39 extents -> $(700*2+6190/10)/53=38.09$.

RAID capacities

Use the following information to calculate the raw and usable capacity for High Performance Flash Enclosures Gen3.

RAID 6 is the recommended and default RAID type for all drives over 1 TB. RAID 6 and RAID 10 are the only supported RAID types for 3.84 TB Flash Tier 1 drives and 1.92 TB, 7.68 TB, and 15.36 TB Flash Tier 2 drives. RAID 5 is not supported for drives larger than 1 TB, and requires a request for price quote (RPQ). For information, contact your sales representative.

Table 20. RAID capacities for High Performance Flash Enclosures Gen3.						
Use the following information to calculate the raw and usable capacity for High Performance Flash Enclosures Gen3.						
Flash drive disk size	Raw capacity of Flash drive set	Rank type	Usable capacity of one rank in number of extents			
			RAID-10 arrays		RAID-6 arrays	
			3 + 3	4 + 4	5 + P + Q	6 + P + Q
800 GB	12.8 TB	FB Lg Ext	2163	2885	3608	4330
		FB Sm Ext	138462	184701	230935	277159
		CKD Lg Ext	2426	3236	4046	4857
		CKD Sm Ext	128604	171551	214488	257438
1.6 TB	25.6 TB	FB Lg Ext	4331	5776	7221	8666
		FB Sm Ext	277204	369691	462163	554647
		CKD Lg Ext	4857	6478	8099	9719
		CKD Sm Ext	257467	343369	429258	515155
1.92 TB	30.7 TB	FB Lg Ext	5198	6932	8666	10400
		FB Sm Ext	332703	443689	554668	665647
		CKD Lg Ext	5830	7775	9720	11665
		CKD Sm Ext	309014	412009	515174	618257
3.2 TB	51.2 TB	FB Lg Ext	8667	11557	14447	17337
		FB Sm Ext	554691	739673	924653	1109623
		CKD Lg Ext	9720	12962	16204	19445
		CKD Sm Ext	515197	687009	858812	1030627
3.84 TB	61.4 TB	FB Lg Ext	10401	13869	17338	20806
		FB Sm Ext	665686	887667	1109645	1331623
		CKD Lg Ext	11665	15555	19445	23336
		CKD Sm Ext	618289	824465	1030630	1236812
7.68 TB	123 TB	FB Lg Ext	20807	27744	34680	41617
		FB Sm Ext	1331653	1775623	2219583	2663551
		CKD Lg Ext	23336	31116	38897	46677
		CKD Sm Ext	1236838	1649196	2061542	2473901
15.36 TB	246 TB	FB Lg Ext	41404	55207	69010	82812
		FB Sm Ext	2649892	3533275	4416655	5300023
		CKD Lg Ext	46438	61918	77399	92880
		CKD Sm Ext	2461216	3281701	4102175	4922665

I/O adapter features

You must select the I/O adapter features that you want for your storage system.

The I/O adapter features are separated into the following categories:

- I/O enclosures
- Host adapters
- Host adapters Fibre Channel cables
- zHyperLink adapter
- zHyperLink cables
- Transparent cloud tiering adapters
- Flash RAID adapters

I/O enclosures

I/O enclosures are required for your storage system configuration.

The I/O enclosures hold the I/O adapters and provide connectivity between the I/O adapters and the storage processors. I/O enclosures are ordered and installed in pairs.

The I/O adapters in the I/O enclosures can be either device or host adapters. Each I/O enclosure pair can support up to four device adapters (two pairs), and up to eight host adapters (not to exceed 32 host adapter ports).

Feature codes for I/O enclosures

Use this feature code to order I/O enclosures for your storage system.

The I/O enclosure feature includes two I/O enclosures. This feature supports up to two device adapter pairs, and up to eight host adapters with four ports.

Feature code	Description
AAT0	I/O enclosure pair PCIe Gen4

Feature codes for I/O cables

I/O cables connect device and host adapters in an I/O enclosure pair to the processor. Use these feature codes to order an I/O cable if your storage system includes the model E96 expansion frame.

Feature Code	Cable Group	Description	Models
AB00	Adjacent expansion PCIE4 Cables	Provides the cables required to attach an expansion frame next to a base frame	E05
AB01	20 meter expansion PCIE4 Cables	Provides the cables required to attach an expansion frame up to 20 meters away from a base frame	E05

Fibre Channel (SCSI-FCP and FICON) host adapters and cables

You can order Fibre Channel host adapters for your storage-system configuration.

The Fibre Channel host adapters enable the storage system to attach to Fibre Channel (SCSI-FCP) and FICON servers, and SAN fabric components. They are also used for remote mirror and copy control paths between DS8000 series storage systems. Fibre Channel host adapters are installed in an I/O enclosure.

Adapters are 4-port 32 Gbps.

Supported protocols include the following types:

- SCSI-FCP upper layer protocol (ULP) on point-to-point or fabric topologies.
- FICON ULP on point-to-point and fabric topologies.

Notes:

1. SCSI-FCP and FICON are supported simultaneously on the same adapter, but not on the same port.
2. For highest availability, ensure that you add adapters in pairs.

A Fibre Channel cable is required to attach each Fibre Channel adapter port to a server or fabric component port. The Fibre Channel cables can be 50 or 9 micron, OM3 or higher fiber graded, single or multimode cables.

Feature codes for Fibre Channel host adapters

Use these feature codes to order Fibre Channel host adapters for your storage system.

Feature code	Feature	Description
AAE0	32 Gb 4 Port SW FCP/FICON Adapter PCIe	Provides one four-port Fibre Channel/FICON host adapter. Host adapters are installed in an I/O enclosure. For higher availability, adapters should be added in pairs and in a balanced manner across the machine.
AAE1	32 Gb 4 Port LW FCP/FICON Adapter PCIe	Provides one four-port Fibre Channel/FICON host adapter. Host adapters are installed in an I/O enclosure. For higher availability, adapters should be added in pairs and in a balanced manner across the machine.

Feature codes for Fibre Channel cables

Use these feature codes to order Fibre Channel cables to connect Fibre Channel host adapters to your storage system. Take note of the distance capabilities for cable types.

Feature code	Feature	Description
AB10	40 meter, 50um Fibre cable (LC/LC)	Provides one Fibre Channel cable to connect a Fibre Channel/FICON adapter port to a server or fabric component port. Each cable has a LC connector for attachment to the Fibre Channel/FICON adapter port. Cables are available with a LC connector for attachment to the server or fabric component port. The 50 micron cables are compatible with short-wave Fibre Channel/FICON host adapters.
AB11	31 meter, 50um Fibre cable (LC/SC)	Provides one Fibre Channel cable to connect a Fibre Channel/FICON adapter port to a server or fabric component port. Each cable has a LC connector for attachment to the Fibre Channel/FICON adapter port. Cables are available with a LC connector for attachment to the server or fabric component port. The 50 micron cables are compatible with short-wave Fibre Channel/FICON host adapters.
AB12	2 meter, 50um Fibre cable (LC/SC)	Provides a pigtail conversion cable that can be used to attach the Fibre Channel/FICON adapter port to a cable with a LC connector. This feature is compatible with short-wave Fibre Channel/FICON host adapters.
AB13	3 meter, 50um Fibre cable (LC/LC)	Provides one Fibre Channel cable to connect a Fibre Channel/FICON adapter port to a server or fabric component port. Each cable has a LC connector for attachment to the Fibre Channel/FICON adapter port. Cables are available with a LC connector for attachment to the server or fabric component port. The 50 micron cables are compatible with short-wave Fibre Channel/FICON host adapters.

Table 24. Feature codes for Fibre Channel cables (continued)

Feature code	Feature	Description
AB20	31 meter, 9um Fibre cable (LC/LC)	Provides one Fibre Channel cable to connect a Fibre Channel/FICON adapter port to a server or fabric component port. Each cable has a LC connector for attachment to the Fibre Channel/FICON adapter port. The cables are available with a LC connector for attachment to the server or fabric component port. The 9 micron cables are compatible with long-wave Fibre Channel/FICON adapters.
AB21	31 meter, 9um Fibre cable (LC/SC)	Provides one Fibre Channel cable to connect a Fibre Channel/FICON adapter port to a server or fabric component port. Each cable has a LC connector for attachment to the Fibre Channel/FICON adapter port. The cables are available with a LC connector for attachment to the server or fabric component port. The 9 micron cables are compatible with long-wave Fibre Channel/FICON adapters.
AB22	2 meter, 9um Fibre cable (LC/SC)	Provides a pigtail conversion cable that can be used to attach the Fibre Channel/FICON adapter port to a cable with a LC connector. This feature is compatible with long-wave Fibre Channel/FICON host adapters.
AB23	3 meter, 9um Fibre cable (LC/LC)	Provides one Fibre Channel cable to connect a Fibre Channel/FICON adapter port to a server or fabric component port. Each cable has a LC connector for attachment to the Fibre Channel/FICON adapter port. The cables are available with a LC connector for attachment to the server or fabric component port. The 9 micron cables are compatible with long-wave Fibre Channel/FICON adapters.

Feature codes for overhead cable management (top-exit bracket)

Use this feature code to order cable management for overhead cabling (top-exit bracket) for your IBM Storage DS8000 (10th Generation) Model A01, A05, or E05.

Note: In addition to the top-exit bracket, one ladder (feature code AAX0) must also be purchased for a site where the top-exit bracket for fiber cable feature is used. The ladder is used to ensure safe access when your storage system is serviced with a top-exit bracket feature installed.

Table 25. Feature codes for the overhead cable (top-exit bracket)

Feature Code	Description
AAV1	Top exit bracket for fibre cable

zHyperLink adapters and cables

You can order zHyperLink adapters for your storage system configuration.

zHyperLink connections with IBM Z hosts provide low latency for random reads and writes.

Note: The z-synergy Services license is required for zHyperLink.

Feature codes for zHyperLink adapters

Use these feature codes to order zHyperLink I/O adapters.

Each zHyperLink connection requires a zHyperLink adapter to connect the zHyperLink cable to the storage system. Each zHyperLink adapter card has one port, but you must order them in sets of two.

Feature code	Feature	Description
AAG0	zHyperLink adapter	Provides a one port zHyperlink adapter which resides in the PCIe G4 I/O drawer of the DS8000 and supports direct connectivity to IBM Z at distances up to 150 m.

Feature codes for zHyperLink cables

Use these feature codes to order cables to connect zHyperLink I/O adapters to the storage system. Take note of the distance capabilities for cable types.

Feature code	Feature	Description
AB30	40m zHyperLink cable	Provides one zHyperlink cable to connect a zHyperlink adapter port to a server or port of the zHyperLink Express feature. It is a single 24-fiber cable with Multi-fiber Termination Push-on (MTP) connectors. Internally, the cable houses 12 fibers for transmit and 12 fibers for receive. The specifications of the cable are: 40m, OM4 50/125 micrometer multimode fiber optic cable with a fiber bandwidth at wavelength: 4.7 GHz-km at 850 nm.

Feature code	Feature	Description
AB31	150m zHyperLink cable	Provides one zHyperlink cable to connect a zHyperlink adapter port to a server or port of the zHyperLink Express feature. It is a single 24-fiber cable with Multi-fiber Termination Push-on (MTP) connectors. Internally, the cable houses 12 fibers for transmit and 12 fibers for receive. The specifications of the cable are: 150m, OM4 50/125 micrometer multimode fiber optic cable with a fiber bandwidth at wavelength: 4.7 GHz-km at 850 nm.

Feature codes for Transparent cloud tiering adapters

Use these feature codes to order adapter pairs to enhance Transparent cloud tiering connectivity for your storage system.

Transparent cloud tiering connectivity can be enhanced with 10 Gbps adapter pairs to improve bandwidth for a native cloud storage tier in IBM Z environments.

Feature code	Feature	Description
AAH0	TCT 10Gb/1Gb ethernet pair for 2U controllers_SR	Provides a pair of 2-port 10 Gbps SFP+ shortwave optical (one for each one of the central electronics complexes) to improve bandwidth for a native cloud storage tier in IBM Z environments. OM3 or OM4 Multimode 50/125 micron fiber is required.
AAJ0	TCT 10Gb/1Gb ethernet pair for 4U controllers_SR	Provides a pair of 2-port 10 Gbps SFP+ shortwave optical (one for each one of the central electronics complexes) to improve bandwidth for a native cloud storage tier in IBM Z environments. OM3 or OM4 Multimode 50/125 micron fiber is required.

Feature codes for flash RAID adapters

Use these feature codes to order flash RAID adapters.

You must order a flash RAID adapter pair for each High-Performance Flash Enclosure Gen3 pair.

<i>Table 28. Feature codes for flash RAID adapters</i>		
Feature code	Description	Models
AAD0	HPFE Gen3 adapter card pair	Model A01, A05, E05

Processor node features

These features specify the number and type of core processors in the processor node. All base frames contain two processor enclosures (POWER9 servers) that contain the processors and memory that drives all functions in the storage system.

Feature codes for processor licenses

Use these processor-license feature codes to plan for and order processor memory for your storage system. You can order only one processor license per system.

<i>Table 29. Feature codes for processor licenses</i>		
Feature code	Description	Corequisite feature code for memory
4341	8-core POWER9 processor feature	4450 or 4451
4342	10-core POWER9 processor feature	4452
4343	Second 10-core POWER9 processor feature for 20-core configuration	4453 or 4454
4344	22-core POWER9 processor feature	4456

Processor memory features

These features specify the amount of memory that you need depending on the processors in the storage system.

Feature codes for system memory

Use these feature codes to order system memory for your storage system.

Note: Memory is not the same as cache. The amount of cache is less than the amount of available memory. See the DS8000 Storage Management GUI.

<i>Table 30. Feature codes for system memory</i>		
Feature code	Description	Corequisite feature code for processor license
4450	192 GB system memory	4341 (8-core)
4451	512 GB system memory	4341 (8-core)
4452	512 GB system memory	4342 (10-core)
4453	1024 GB system memory	4342 and 4343 (20-core)

Table 30. Feature codes for system memory (continued)

Feature code	Description	Corequisite feature code for processor license
4454	2048 GB system memory	4342 and 4343 (20-core)
4455	3456 GB system memory	4342 and 4343 (20-core)
4456	4352 GB system memory	4344 (22-core)
4457	2048 GB system memory	4342 and 4343 (20-core)
4458	3456 GB system memory	4342 and 4343 (20-core)

Power features

You must specify the power features to include on your storage system.

The power features are separated into the following categories:

- Power cords
- Input voltage

Power cords

Each feature code represents a pair of power cords (two cords).

The DS8000 series has redundant pairs of intelligent Power Distribution Units (iPDUs). For redundancy, provide connections from two independent power sources.

Feature codes for power cords

Use these feature codes to order power cords for the IBM Storage DS8000 (10th Generation) base or expansion racks.

Each feature code includes two power cords and an iPDU pair. Ensure that you meet the requirements for each power cord and connector type that you order.

Ensure that you order the correct number of power cord features.

Table 31. Power cord features for model A01, A05, and E05







Model	Number needed
A01 or A05 with one Gen3 I/O enclosure pair (feature code AAT0) and one High Performance Flash Enclosure Gen3 pair (feature code AACA)	1 feature (2 cords)
E05	
A01 or A05 with more than one Gen3 I/O enclosure pair (feature code AAT0) or more than one High Performance Flash Enclosure Gen3 pair (feature code AACA)	2 features (4 cords)

Important: A minimum of one safety-approved ladder (feature code 1101) must be available at each installation site when the top exit bracket (feature code 1401) is specified for overhead cabling and when the maximum height of the overhead power source is 10 ft from the ground level. This ladder is a requirement for storage-system installation and service.



Attention: The regional designations are general. If the input voltage for the country uses a wye circuit, use the appropriate main power cables for EMEA (Europe, Middle East, and Africa) and Asia/Pacific. If input voltage for the country uses a delta circuit, use the appropriate main power cables for United States, Canada, and Latin America. For more information about electric currents for various countries, see the International Trade Administration website (<http://trade.gov>).

Note: The IEC 60309 standard commercial/industrial pin and sleeve power connectors are often abbreviated "IEC '309" or simply "309 wall plug".

<i>Table 32. Feature codes for power cords</i>			
Feature code	Feature	Description	Input connector diagram
AAS0	Single Phase Power - 208V 30A NEMA L6-30P	Provides the primary source of power for the storage system with Single Phase Power - 208V 30A NEMA L6-30P power cords.	
AAS1	Single Phase Power - 250V 30A/32A IEC 60309	Provides the primary source of power for the storage system with Single Phase Power - 250V 32A IEC 309 power cords.	
AAS3	3 Phase Wye Power - 380/220-415/240V (LL/LN) 30A/32A, IEC60309 (5 pin 3+N+PE)	Provides the primary source of power for the storage system with 3 Phase Power - 250V 32A IEC 309 (5 pin Wye) power cords.	
AAS4	Single Phase Power - 250V 32A, Australia/New Zealand	Provides the primary source of power for the storage system with Single Phase Power - 250V 32A power cords.	
AAS5	Single Phase Power - 250V 30A, Korea	Provides the primary source of power for the storage system with Single Phase Power - 250V 30A power cords.	
AAS6	Single Phase Power - 230V 30A/32A, halogen free IEC 60309	Provides the primary source of power for the storage system with Single Phase Power - 230V 32A, halogen free IEC 390 power cords	

Configuration rules for power features

Ensure that you are familiar with the configuration rules and feature codes before you order power features.

When you order power cord features, the following rules apply.

- Each feature code represents a pair of power cords (two cords). To determine the number of features to order for your model configuration, see “Feature codes for power cords” on page 93.
- You must select the power cord that is appropriate to the input voltage and geographic region where the storage system is located.

Other configuration features

Features are available for shipping and setting up the storage system.

You can select shipping and setup options for the storage system. The following list identifies optional feature codes that you can specify to customize or to receive your storage system.

- BSMI certificate (Taiwan)
- Shipping weight reduction option

BSMI certificate (Taiwan)

The BSMI certificate for Taiwan option provides the required Bureau of Standards, Metrology, and Inspection (BSMI) ISO 9001 certification documents for storage system shipments to Taiwan.

If the storage system that you order is shipped to Taiwan, you must order this option for each model that is shipped.

Feature code for BSMI certification documents (Taiwan)

Use this feature code to order the Bureau of Standards, Metrology, and Inspection (BSMI) certification documents that are required when the storage system is shipped to Taiwan.

<i>Table 33. Feature code for the BSMI certification documents (Taiwan)</i>	
Feature code	Description
0400	BSMI certification documents

Chapter 5. Licensed functions

Licensed functions are the operating system and functions of the storage system. Required features and optional features are included.

IBM® authorization for licensed functions is purchased as 5341 or 9031 machine function authorizations. However, the license functions are storage models. For example, the Base Function license is listed as a 5341 or 9031 model FFA. The 5341 or 9031 machine function authorization features are for billing purposes only.

The following licensed functions are available:

Base Function

The Base Function license is required for each storage system.

z-synergy Services

The z-synergy Services include z/OS licensed features that are supported on the storage system.

Copy Services

Copy Services features help you implement storage solutions to keep your business running 24 hours a day, 7 days a week by providing data duplication, data migration, and disaster recovery functions.

Transparent Cloud Tiering

Transparent Cloud Tiering (TCT) license provides a native cloud storage tier for IBM® Z environments. Transparent cloud tiering moves data directly from the storage system to cloud object storage, without sending data through the host.

Licensed function indicators

Each licensed function indicator feature that you order on a base frame enables that function at the system level.

After you receive and apply the feature activation codes for the licensed function indicators, the licensed functions are enabled for you to use. The licensed function indicators are also used for maintenance billing purposes.

Note: Retrieving feature activation codes is part of managing and activating your licenses. Before you can logically configure your storage system, you must first manage and activate your licenses.

Each licensed function indicator requires a corequisite 9031 function authorization. Function authorization establishes the extent for the licensed function before the feature activation code is provided. Each function authorization applies only to the specific storage system (by serial number) for which it was acquired. The function authorization cannot be transferred to another storage system (with a different serial number).

License scope

Licensed functions are activated and enforced within a defined license scope.

License scope refers to the following types of storage and types of servers with which the function can be used:

Fixed block (FB)

The function can be used only with data from Fibre Channel attached servers. The Base Function, and Copy Services licensed functions are available within this scope.

Count key data (CKD)

The function can be used only with data from FICON attached servers. The Copy Services, Transparent Cloud Tiering, and z-synergy Services licensed functions are available within this scope.

Both FB and CKD (ALL)

The function can be used with data from all attached servers. The Base Function, and Copy Services licensed functions are available within this scope.

Some licensed functions have multiple license scope options, while other functions have only a single license scope.

You do not specify the license scope when you order function authorization feature numbers. Feature numbers establish only the extent of the authorization (in terms of usable capacity), regardless of the storage type. However, if a licensed function has multiple license scope options, you must select a license scope when you initially retrieve the feature activation codes for your storage system. This activity is performed by using the [IBM Entitled Systems Support \(ESS\) website](#).

Note: Retrieving feature activation codes is part of managing and activating your licenses. Before you can logically configure your storage system, you must first manage and activate your licenses.

When you use the ESS website to change the license scope after a licensed function is activated, a new feature activation code is generated. When you install the new feature activation code into the storage system, the function is activated and enforced by using the newly selected license scope. The increase in the license scope (changing FB or CKD to ALL) is a nondisruptive activity. A reduction of the license scope (changing ALL to FB or CKD) is a disruptive activity, which takes effect at the next restart.

Ordering licensed functions

After you decide which licensed functions to use with your storage system, you are ready to order the functions.

About this task

Licensed functions are purchased as function authorization features.

To order licensed functions, use the following general steps:

Procedure

1. Required. Order the Base Function license to support the raw capacity of your storage system.
2. Optional. Order the z-synergy Services license to support the raw capacity of all arrays that are formatted as CKD.
3. Optional. Order the Copy Services license to support the provisioned capacity of all volumes that are involved in one or more copy services functions.
4. Optional. Order the Transparent Cloud Tiering license to support the raw capacity of all arrays that are formatted as CKD.

Rules for ordering licensed functions

A Base Function license is required for every base frame.

For all licensed functions, you can combine feature codes to order the exact capacity that you need. For example, if you require 160 TB of capacity, order 10 of feature code BAA0 (10 TB each up to 100 TB capacity) and 4 of feature code BAA1 (15 TB each, for an extra 60 TB).

If you order the Copy Services license, you must order the Copy Services license for the provisioned capacity of all of the volumes that will be used for the Copy Services relationships.

When you calculate raw capacity, consider the capacity across the entire storage system, including the base frame and any expansion frames. To calculate the raw capacity, use the following table to determine the total size of each regular drive feature in your storage system, and then add all the values.

Table 34. Total raw capacity for drive-set features

Drive sizes	Total raw capacity	Drives per feature
1.6 TB NVMe drives	25.6 TB	16
1.9 TB NVMe drives	30.4 TB	16
3.8 TB NVMe drives	60.8 TB	16
7.6 TB NVMe drives	121.6 TB	16
4.8 TB FlashCore Modules (FCM)	76.8 TB	16
9.6 TB FCM	153.6 TB	16
19.2 TB FCM	307.2 TB	16

Rules for removing a licensed function

The initial enablement of any optional DS8000 licensed function is a concurrent activity (assuming that the appropriate level of microcode is installed on the machine for the specific function). The removal of a DS8000 licensed function is a nondisruptive activity but takes effect at the next machine IML.

If you have a licensed function and no longer want to use it, you can deactivate the license in one of the following ways:

- Order an inactive or disabled license and replace the active license activation key with the new inactive license activation key at the [IBM® Entitled Systems Support \(ESS\) website](#).
- Go to the ESS website and change the assigned value from the current number of terabytes (TB) to 0 TB. This value, in effect, makes the feature inactive. If this change is made, you can go back to ESS and reactivate the feature, up to the previously purchased level, without having to repurchase the feature.

Regardless of which method is used, the deactivation of a licensed function is a nondisruptive activity, but takes effect at the next machine IML.

Note: Although you do not need to specify how the licenses are to be applied when you order them, you must allocate the licenses to the storage image when you obtain your license keys on the [IBM® Entitled Systems Support \(ESS\) website](#).

Base Function license

The Base Function license provides essential functions for your storage system. A Base Function license is required for each storage system.

The Base Function license is available for the following license scopes: FB and ALL (both FB and CKD).

- Encryption Authorization
- Logical configuration support for FB
- Space Reclamation (Unmap)
- Dynamic Volume Expansion
- FB Compression using FlashCore Modules
- Local Key Manager for Data at Rest
- Secure Boot
- Multifactor Authorization
- LDAP
- Easy Tier
- Operating Environment License (OEL)
- Thick/Thin Provisioned Volume support

The Base Function license feature codes are ordered in increments up to a specific capacity. For example, if you require 160 TB of capacity, order 10 of feature code BAA0 (10 TB each up to 100 TB capacity) and 4 of feature code BAA1 (15 TB each, for an extra 60 TB).

The Base Function license includes the following feature codes.

Feature Code	Feature code for licensed function indicator
BAA0	BF 10TB increments from 0 to 100 TB
BAA1	BF 15TB increments from 100.1 TB to 250 TB
BAA2	BF 25TB increments from 250.1 TB to 500 TB
BAA3	BF 75TB increments from 500.1 TB to 1250 TB
BAA4	BF 175TB increments from 1250.1 TB to 3000 TB
BAA5	BF 300TB increments from 3000.1 TB to 6000 TB
BAA6	BF 600TB increments from 6000.1 TB to 12000 TB

Base Function license rules

The Base Function license authorizes you to use the model configuration at a specific capacity level. The Base Function license must cover the full raw capacity of your storage system, which includes the raw capacity of any expansion frames within the storage system. The license capacity must cover both open systems data (fixed block data) and IBM® Z data (count key data). Copy Services, Transparent Cloud Tiering and z-synergy Services must have a capacity that is equal to or less than the Base Function License.

Note: Your storage system cannot be logically configured until you activate the Base Function license. On activation, drives can be logically configured up to the extent of the Base Function license authorization level.

As you add more drives to your storage system, you must increase the Base Function license authorization level for the storage system by purchasing more license features. Otherwise, you cannot logically configure the additional drives for use.

Encryption Authorization

The Encryption Authorization feature provides data encryption by using IBM Full Disk Encryption (FDE) and key managers, such as IBM Security Guardium Key Lifecycle Manager.

The Encryption Authorization feature secures data at rest and offers a simple, cost-effective solution for securely erasing any disk drive that is being retired or re-purposed (cryptographic erasure). The storage system uses disks that have FDE encryption hardware and can perform symmetric encryption and decryption of data at full disk speed with no impact on performance.

Note: The Encryption Authorization feature is part of the Base Function license and is only available for certain countries.

IBM Easy Tier

Support for IBM Easy Tier is available with the IBM Easy Tier feature.

The Easy Tier feature enables the following modes:

- Easy Tier: automatic mode
- Easy Tier: manual mode

The feature enables the following functions for the storage type:

- Easy Tier application
- Easy Tier heat map transfer
- The capability to migrate volumes for logical volumes
- The reconfigure extent pool function of the extent pool
- The dynamic extent relocation with an Easy Tier managed extent pool

Operating environment license

The operating environment model and features establish the extent (capacity) that is authorized to use the product operating environment.

To determine the operating environment license support function, see [“Machine types overview” on page 2](#).

Thin provisioning

Thin provisioning defines logical volume sizes that are larger than the usable capacity installed on the system. The volume allocates capacity on an as-needed basis as a result of host-write actions.

The thin provisioning feature enables the creation of extent space efficient logical volumes. Extent space efficient volumes are supported for FB and CKD volumes and are supported for all Copy Services functionality, including FlashCopy targets where they provide a space efficient FlashCopy capability.

z-synergy Services license

The z-synergy Services license includes z/OS® features that are supported on the storage system.

The z-synergy Services license includes the following features:

- Logical configuration support for CKD
- High Performance FICON for z Systems®
- zPAV / Hyper-PAV / Super PAV
- Parallel Access Volumes (PAV)
- FICON Dynamic Routing, Forward Error Correction
- Dynamic Volume Expansion
- zDDB, IBM Sterling MFT Acceleration with zDDB
- Thick/Thin Provisioned Volume support for CKD
- IBM z/OS Distributed Data Backup
- zHyperWrite
- zHyperLink
- z/DS8000 EasyTier Application
- GDPS Heat Map Transfer
- Fibre Channel Endpoint Security – Auth and EDiF
- CKD Compression using FlashCore Modules (FCM)
- zHPF Extended Distance II
- z/OS Distributed Data Backup
- zHyperLink
- IBM Fibre Channel Endpoint Security

The z-synergy Services license also includes the ability to attach FICON channels.

The z-synergy Services license feature codes are ordered in increments up to a specific capacity. For example, if you require 160 TB of capacity, order 10 of feature code BAC2 (10 TB each up to 100 TB capacity), and 4 of feature code BAC3 (15 TB each, for an extra 60 TB).

The z-synergy Services license includes the feature codes listed in the following table.

Feature Code	Feature code for licensed function indicator
BAC0	zsS - Active
BAC1	zsS - Inactive
BAC2	zsS 10TB increments from 0 to 100 TB
BAC3	zsS 15TB increments from 100.1 TB to 250 TB
BAC4	zsS 25TB increments from 250.1 TB to 500 TB
BAC5	zsS 75TB increments from 500.1 TB to 1250 TB
BAC6	zsS 175TB increments from 1250.1 TB to 3000 TB
BAC7	zsS 300TB increments from 3000.1 TB to 6000 TB
BAC8	zsS 600TB increments from 6000.1 TB to 12000 TB

z-synergy Services license rules

A z-synergy Services license is required for the raw capacity of all arrays that are formatted as CKD if the DS8000 needs to use count key data (CKD) arrays for use with IBM® Z host systems.

High Performance FICON for z Systems

High Performance FICON for z Systems (zHPF) is an enhancement to the IBM FICON architecture to offload I/O management processing from the z Systems channel subsystem to the DS8000 10th generation Host Adapter and controller.

zHPF is an optional feature of z Systems server and of the DS8000 10th generation. Recent enhancements to zHPF include Extended Distance Facility zHPF List Pre-fetch support for IBM DB2® and utility operations, and zHPF support for sequential access methods. All of DB2 I/O is now zHPF-capable.

IBM HyperPAV

IBM HyperPAV associates the volumes with either an alias address or a specified base logical volume number. When a host system requests IBM HyperPAV processing and the processing is enabled, aliases on the logical subsystem are placed in an IBM HyperPAV alias access state on all logical paths with a given path group ID.

Parallel Access Volumes

The parallel access volumes (PAV) features establish the extent of IBM authorization for the use of the parallel access volumes function.

Parallel Access Volumes (PAVs), also referred to as aliases, provide your system with access to volumes in parallel when you use an IBM Z host.

A PAV capability represents a significant performance improvement by the storage unit over traditional I/O processing. With PAVs, your system can access a single volume from a single host with multiple concurrent requests.

z/OS Distributed Data Backup

z/OS Distributed Data Backup (zDDB) is a licensed feature on the base frame that allows hosts, which are attached through a FICON interface, to access data on fixed block (FB) volumes through a device address on FICON interfaces.

If zDDB is installed and enabled and a volume group type specifies either FICON interfaces, this volume group has implicit access to all FB logical volumes that are configured in addition to all CKD volumes specified in the volume group. Then, with appropriate software, a z/OS host can complete backup and restore functions for FB logical volumes that are configured on a storage system image for open systems hosts.

zHyperLink

zHyperLink is a short distance link technology that is designed for up to 10 times lower latency than zHPF.

zHyperLink can speed up transaction processing and improve active log throughput.

zHyperLink is intended to complement FICON technology to accelerate I/O requests that are typically used for transaction processing.

IBM Fibre Channel Endpoint Security

Use IBM Fibre Channel Endpoint Security to establish authenticated communication and encryption of data in flight for Fibre Channel connections between an IBM z15 host and the storage system. The connections are secured by Fibre Channel security protocols and key server authentication that uses communication certificates. If both the host and storage system use a connection with Fibre Channel ports that support encryption, the connection will transmit encrypted data between the ports.

Transparent cloud tiering

Transparent Cloud Tiering (TCT) provides a native cloud storage tier for IBM® Z environments. Transparent cloud tiering moves data directly from the storage system to cloud object storage, without sending data through the host.

Transparent cloud tiering provides cloud object storage (public, private, or on-premises) as a secure, reliable, transparent storage tier that is natively integrated with the storage system. Transparent cloud tiering on the storage system is fully integrated with DFSMSHsm, which reduces CPU utilization on the host when you are migrating and recalling data in cloud storage. You can use the IBM Z host to manage transparent cloud tiering and attach metadata to cloud objects.

The z-synergy Services license includes the following features:

- Multi-Cloud on/off Premises Support
- Transparent Cloud Tiering Encryption Support
- Compression for TS7700

A Transparent Cloud Tiering license is required for the raw capacity of all arrays that are formatted as CKD if the DS8000 needs to use Transparent Cloud Tiering.

The Transparent Cloud Tiering license includes the feature codes listed in the following table.

Table 1. Transparent Cloud Tiering license feature codes

Feature Code	Feature code for licensed function indicator
BAD0	TCT - Active
BAD1	TCT - Inactive
BAD2	TCT 10TB increments from 0 to 100 TB
BAD3	TCT 15TB increments from 100.1 TB to 250 TB

Feature Code	Feature code for licensed function indicator
BAD4	TCT 25TB increments from 250.1 TB to 500 TB
BAD5	TCT 75TB increments from 500.1 TB to 1250 TB
BAD6	TCT 175TB increments from 1250.1 TB to 3000 TB
BAD7	TCT 300TB increments from 3000.1 TB to 6000 TB
BAD8	TCT 600T increments from 6000.1 TB to 12000 TB

The storage system supports the OpenStack Swift and Amazon S3 APIs. The storage system also supports the IBM TS7700 as an object storage target and the following cloud service providers:

- Amazon S3
- IBM Cloud Object Storage
- OpenStack Swift Based Private Cloud

Copy Services license

Copy Services features help you implement storage solutions to keep your business running 24 hours a day, 7 days a week by providing data duplication, data migration, and disaster recovery functions. The Copy Services license is based on provisioned capacity of the volumes involved in Copy Services functionality.

Copy Services features help you implement storage solutions to keep your business running 24 hours a day, 7 days a week by providing data duplication, data migration, and disaster recovery functions. The Copy Services license is based on provisioned capacity of the volumes involved in Copy Services functionality.

The Copy Services license includes the following features:

- Global Mirror
- Metro Mirror
- Metro/Global Mirror
- Point-in-Time Copy/FlashCopy
- Safeguarded Copy
- z/OS Global Mirror
- z/OS Metro/Global Mirror Incremental Resync (RMZ)
- Multi-Target-PPRC
- Cascaded Incremental Resync (6-Site Replication)
- HyperSwap
- Copy Services Manager on the Hardware Management Console

The Copy Services license feature codes are ordered in increments up to a specific capacity. For example, if you require 160 TB of capacity, order 10 of feature code BAB1 (10 TB each up to 100 TB capacity), and 4 of feature code BAB2 (15 TB each, for an extra 60 TB).

The Copy Services license includes the following feature codes.

Feature Code	Feature code for licensed function indicator
BAB1	CS - inactive
BAB2	CS - 10 TB (up to 100 TB capacity)
BAB3	CS - 15 TB (from 100.1 TB to 250 TB capacity)

Table 37. Copy Services license feature codes (continued)

Feature Code	Feature code for licensed function indicator
BAB4	CS - 25 TB (from 250.1 TB to 500 TB capacity)
BAB5	CS - 75 TB (from 500.1 to 1250 TB capacity)
BAB6	CS - 175 TB (from 1250.1 TB to 3000 TB capacity)
BAB7	CS - 300 TB (from 3000.1 TB to 6000 TB capacity)

Copy Services license rules

The following ordering rules apply when you order the Copy Services license:

- The Copy Services license should be ordered based on the provisioned capacity of all volumes involved in one or more Copy Services relationships.
- The licensed authorization must be equal to or less than the provisioned capacity allocated to the volumes that participate in Copy Services operations.
- You must purchase features for both the source (primary) and target (secondary) storage system.

Remote mirror and copy functions

The Copy Services license establishes the extent of IBM authorization for the use of the remote mirror and copy functions on your storage system.

The following functions are included:

- Metro Mirror
- Global Mirror
- Global Copy
- Metro/Global Mirror
- Multiple Target PPRC

FlashCopy function (point-in-time copy)

FlashCopy creates a copy of a source volume on the target volume. This copy is called a point-in-time copy.

When you initiate a FlashCopy operation, a FlashCopy relationship is created between a source volume and target volume. A FlashCopy relationship is a "mapping" of the FlashCopy source volume and a FlashCopy target volume. This mapping allows a point-in-time copy of that source volume to be copied to the associated target volume. The FlashCopy relationship exists between this volume pair from the time that you initiate a FlashCopy operation until the storage unit copies all data from the source volume to the target volume or you delete the FlashCopy relationship, if it is a persistent FlashCopy.

Safeguarded Copy

The Safeguarded Copy feature, available with the Copy Services license, creates backups of data that you can restore to the source volume or a different volume.

The Safeguarded Copy feature creates safeguarded backups that are not accessible by the host system and protects these backups from corruption that can occur in the production environment. You can define a Safeguarded Copy schedule to create multiple backups on a regular basis, such as hourly or daily. You can also restore a backup to the source volume or to a different volume. A backup contains the same metadata as the safeguarded source volume.

Safeguarded Copy can create backups with more frequency and capacity in comparison to FlashCopy volumes. The creation of safeguarded backups also impacts performance less than the multiple target volumes that are created by FlashCopy.

With backups that are outside of the production environment, you can use the backups to restore your environment back to a specified point in time. You can also extract and restore specific data from the backup or use the backup to diagnose production issues.

You cannot delete a safeguarded source volume before the safeguarded backups are deleted. The maximum size of a backup is 16 TB.

Local Data-at-Rest Encryption license

The Local Data-at-Rest Encryption license provides support for local encryption, allowing the storage system to generate and store data keys in its own key repository, therefore eliminating the need of an external key server. The keys are scrambled using a cryptographic algorithm and managed locally rather than being obtained as secrets managed by external key servers.

The Local Data-at-Rest Encryption license is available for the following storage types: ALL (both FB and CKD)

The Local Data-at-Rest Encryption license includes the following features:

- Local Encryption

The Local Encryption feature provides encryption of data at rest and supports local key management.

Important: The Base Function license, which includes the Local Data-at-Rest license for certain countries, must be added by the customer at the time of array initialization.

Chapter 6. Delivery and installation requirements

You must ensure that you properly plan for the delivery and installation of your storage system.

This information provides the following planning information for the delivery and installation of your storage system:

- Planning for delivery of your storage system
- Planning the physical installation site
- Planning for power requirements
- Planning for network and communication requirements

For more information about the equipment and documents that IBM includes with storage system shipments, see [Appendix C, “IBM equipment and documents,”](#) on page 165.

Delivery requirements

Before you receive your storage system shipment, ensure that the final installation site meets all delivery requirements.



Attention: Customers must prepare their environments to accept the storage system based on this planning information, with assistance from an IBM Advanced Technical Services (ATS) representative or a technical service representative. The final installation site within the computer room must be prepared *before* the equipment is delivered. If the site cannot be prepared before the delivery time, customers must make arrangements to have the professional movers return to finish the transportation later. Only professional movers can transport the equipment. The technical service representative can minimally reposition the frame at the installation site, as needed to complete required service actions. Customers are also responsible for using professional movers in the case of equipment relocation or disposal.

Acclimation

Server and storage equipment (racks and frames) must be gradually acclimated to the surrounding environment to prevent condensation.

When server and storage equipment (racks and frames) is shipped in a climate where the outside temperature is below the dew point of the destination (indoor location), there is a possibility that water condensation can form on the cooler inside and outside surfaces of the equipment when the equipment is brought indoors.

Sufficient time must be allowed for the shipped equipment to gradually reach thermal equilibrium with the indoor environment before you remove the shipping bag and energize the equipment. Follow these guidelines to properly acclimate your equipment:

- Leave the system in the shipping bag. If the installation or staging environment allows it, leave the product in the full package to minimize condensation on or within the equipment.
- Allow the packaged product to acclimate for 24 hours.¹ If there are visible signs of condensation (either external or internal to the product) after 24 hours, acclimate the system without the shipping bag for an additional 12 - 24 hours or until no visible condensation remains.
- Acclimate the product away from perforated tiles or other direct sources of forced air convection to minimize excessive condensation on or within the equipment.

¹ Unless otherwise stated by product-specific installation instructions.

Note: Condensation is a normal occurrence, especially when you ship equipment in cold-weather climates. All IBM® products are tested and verified to withstand condensation that is produced under these circumstances. When sufficient time is provided to allow the hardware to gradually acclimate to the indoor environment, there should be no issues with long-term reliability of the product.

Shipment weights and dimensions

You must ensure that your loading dock and receiving area can support the weight and dimensions of the packaged storage system shipment.

You receive one shipping container for each model that you order. Each model is shipped on one or two pallets that are protected by removable cardboard, foam, wood stiffening, and plastic wrap.

Table 38 on page 108 shows the total packaged dimensions and maximum packaged weight of the storage system shipments.

Container	Packaged dimensions	Maximum total weight of model plus shipping material ¹
Model A01	Height 2.22 m (87.7 in.) Width 1 m (39.4 in.) Depth 1.50 m (59.1 in.)	924 kg (2037 lb)
Model A05	Height 2.22 m (87.7 in.) Width 1 m (39.4 in.) Depth 1.50 m (59.1 in.)	924 kg (2037 lb)
Expansion Model E05	Height 2.22 m (87.7 in.) Width 1 m (39.4 in.) Depth 1.50 m (59.1 in.)	603 kg (1330 lb)
1. For maximum weight of each model without packaging, see “Dimensions and weight of individual models” on page 119.		

Receiving delivery

The shipping carrier is responsible for delivering and unloading the storage system as close to its final destination as possible. You must ensure that your loading ramp and your receiving area can accommodate your storage system shipment.

Before you begin

Ensure you read the following caution when you position the rack (model 994, 996, 998, or E96).

CAUTION: The rack cabinet is supplied with native built-in extendable outriggers with small floating supplemental castors as motion anti-tip features. They must all be extended into a latched position before and during cabinet movement or relocation. These native built-in outriggers must not be removed completely, but rather recessed in when finished to ensure they are readily available for future use. (C050)

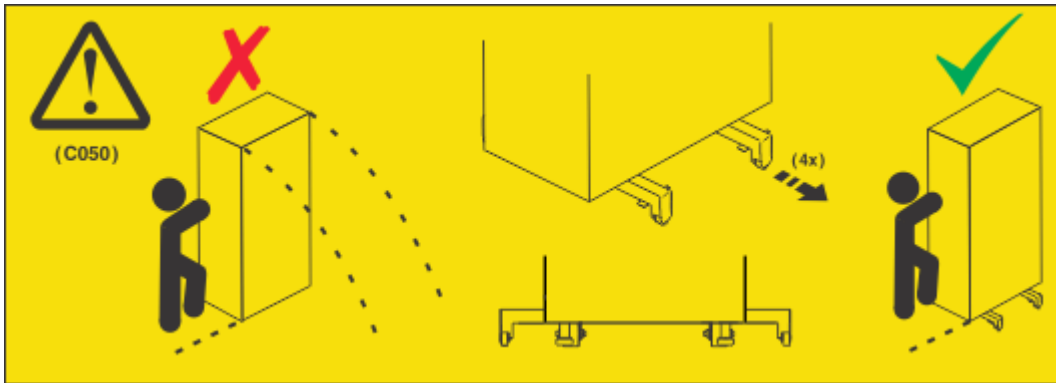

About this task

Use the following steps to ensure that your receiving area and loading ramp can safely accommodate the delivery of your storage system:

Procedure

1. Find out the packaged weight and dimensions of the shipping containers in your shipment.
2. Ensure that your loading dock, receiving area, and elevators can safely support the packaged weight and dimensions of the shipping containers.
3. To compensate for the weight of the storage system shipment, ensure that the loading ramp at your site does not exceed an angle of 10°. (See [Figure 8 on page 109.](#))

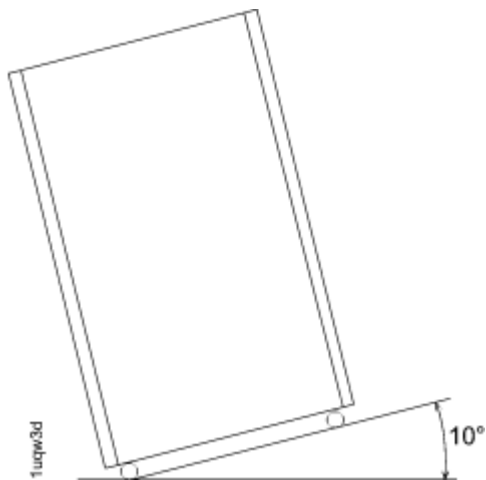

Figure 8. Maximum tilt for a packed frame is 10°

Installation site requirements

You must ensure that the location where you plan to install your storage system meets all requirements.

Planning for floor and space requirements

Ensure that the location where you plan to install your storage system meets space and floor requirements. Decide whether your storage system is to be installed on a raised or nonraised floor.

About this task

When you are planning the location of your storage system, you must answer the following questions that relate to floor types, floor loads, and space:

- What type of floor does the installation site have? The storage system can be installed on a raised or nonraised floor.

- If the installation site has a raised floor, does the floor require preparation (such as cutting out tiles) to accommodate cable entry into the system?
- Does the floor of the installation site meet floor-load requirements?
- Can the installation site accommodate the amount of space that is required by the storage system, and does the space meet the following criteria?
 - Weight distribution area that is needed to meet floor load requirements
 - Service clearance requirements
- Does the installation site require overhead cable management for host fiber and power cables?

Procedure

Use the following steps to ensure that your planned installation site meets space and floor load requirements:

1. Identify the base frame and expansion frame that are included in your storage system.
2. Decide whether to install the storage system on a raised or nonraised floor.
 - a) If the location has a raised floor, plan where the floor tiles must be cut to accommodate the cables.
 - b) If the location has a nonraised floor, resolve any safety problems, and any special equipment considerations, caused by the location of cable exits and routing. Determine if the optional top-exit bracket feature code is required.
3. Determine whether the floor of the installation site meets the floor load requirements for your storage system.
4. Calculate the amount of space to be used by your storage system.
 - a) Identify the total amount of space that is needed for your storage system by using the dimensions of the frames and the weight distribution areas that are calculated in step “3” on page 110.
 - b) Ensure that the area around each frame and each storage system meets the service clearance requirements.

Note: Any expansion frames in the storage system must be attached to the base frame on the right side as you face the front of the storage system.

Installing on raised or nonraised floors

You can install your storage system on a raised or nonraised floor. Raised floors can provide even better cooling than nonraised floors.

Raised floor considerations

Installing your storage system on a raised floor provides the following benefits:

- Improves operational efficiency and allows greater flexibility in the arrangement of equipment.
- Increases air circulation for better cooling.

When you install a raised floor, consider the following factors:

- The raised floor must be constructed of fire-resistant or noncombustible material.
- The raised-floor height must be at least 30.5 cm (12 in.). Clearance must be adequate to accommodate interconnecting cables, Fibre Channel cable raceways, power distribution, and any piping that is present under the floor. Floors with greater raised-floor heights allow for better equipment cooling.
- Fully configured, two-frame storage systems can weigh in excess of 1950 kg (4300 lbs). You must ensure that the raised floor on which the storage system is to be installed is able to support this weight. Contact the floor-tile manufacturer and a structural engineer to verify that the raised floor is safe to support the concentrated loads equal to one third of the total weight of one frame. Under certain circumstances such as relocation, it is possible that the concentrated loads can be as high as one half of the total weight of one frame per caster. When you install two adjacent frames, it is possible that two casters induce a total load as high as one third of the total weight of two adjacent frames.

- Depending on the type of floor tile, more supports (pedestals) might be necessary to maintain the structural integrity of an uncut panel or to restore the integrity of a floor tile that is cut for cable entry or air supply. Contact the floor-tile manufacturer and a structural engineer to ensure that the floor tiles and pedestals can sustain the concentrated loads.
- Pedestals must be firmly attached to the structural (concrete) floor by using an adhesive.
- Seal raised-floor cable openings to prevent chilled air that is not used to directly cool the equipment from escaping.
- Use noncombustible protective molding to eliminate sharp edges on all floor cutouts, to prevent damage to cables and hoses, and to prevent casters from rolling into the floor cutout.
- Avoid the exposure of metal or highly conductive material to the walking surface when a metallic raised floor structure is used. Such exposure is considered an electrical safety hazard.
- Concrete subfloors require treatment to prevent the release of dust.
- The use of a protective covering (such as plywood, tempered masonite, or plyron) is required to prevent damage to floor tiles, carpeting, and tiles while equipment is being moved to or is relocated within the installation site. When the equipment is moved, the dynamic load on the casters is greater than when the equipment is stationary.

Nonraised floor considerations

For environments with nonraised floors, an optional overhead cabling feature is available.

Follow the special considerations and installation guidelines as described in the topics about overhead cable management.

When you install a storage system on a non-raised floor, consider the following factors:

- The use of a protective covering (such as plywood, tempered masonite, or plyron) is required to prevent damage to floor and carpeting while equipment is being moved to or is relocated within the installation site.
- Concrete floors require treatment to prevent the release of dust.

Bottom-exit cable management

Bottom-exit cable management is the standard method for managing your Fibre and Ethernet cables.

Figure 9 on page 112 illustrates the routing of the cabling for bottom-exit. The following notes provide more information about the color-coded cable routing and components.

1 Customer Fibre Channel host cables. The Fibre Channel host cables, shown in red, are routed through the at the bottom of the rack and through the black cable guide behind the bottom rear of each I/O enclosure pair.

2 Network Ethernet cables. The network Ethernet cables, shown in light blue, are routed as shown. The four customer network connections in the rack are cable ends that hang free. They are not installed in a sheet metal bracket. Each cable is labeled as shown in Table 39 on page 111.

3 Mainline power cords. Two or four bottom-exit mainline power cords for each rack, shown in green, are routed during the installation.

Management console Ethernet connection	Cable color	Connector boot color	Label text
HMC1 - Primary	Blue	Purple	HMC1-eth2
HMC1 - Secondary	Blue	Green	HMC1-eth1
HMC2 - Primary	Red	Purple	HMC2-eth2
HMC2 - Secondary	Red	Green	HMC2-eth1

Notes:

- The customer is required to provide and pretest for safety the power outlets (for connecting power cords) within the specified distance.
- Fibre Channel host cables and customer Ethernet cable connections to the HMCs are internally routed and connected by either the customer or by a technical service representative.
- All remaining cables are internally routed and connected by a technical service representative.

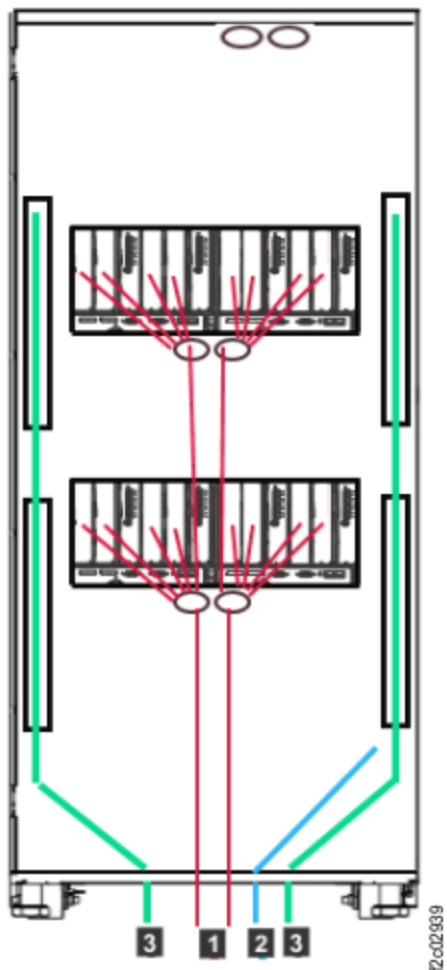

Figure 9. Bottom exit cable routing rear view

Overhead cable management (top-exit bracket)

Overhead cable management requires the optional top-exit bracket (Feature Code 1401) for managing your Fibre and Ethernet cables. This feature is an alternative to the standard bottom-exit.

The installation planning, cable length, and the storage-system location in relation to the cable entry point are critical to the successful installation.

Figure 10 on page 113 illustrates the locations for fiber cables, Ethernet cables, and mainline power cables. The following notes provide more information about the color-coded cable routing and components in Figure 10 on page 113.

1 Customer Fibre Channel host cables. The Fibre Channel host cables, shown in red and dark blue, are routed through the black plastic cable guides at the top of the rack and behind the bottom rear of each I/O enclosure pair.

2 Network Ethernet cables. The network Ethernet cables, shown in light blue, are routed as shown. The four customer network connections in the rack are cable ends that hang free. They are not installed in a sheet metal bracket. Each cable is labeled as shown in Table 39 on page 111.

3 Mainline power cords. Two or four top-exit mainline power cords for each rack, shown in green, are routed during the installation.

Notes:

- The customer is required to provide and pretest for safety the power outlets (for connecting power cords) within the specified distance.
- Fibre Channel host cables and customer Ethernet cable connections to the HMCs are internally routed and connected by a technical service representative.
- All remaining cables are internally routed and connected by a technical service representative.

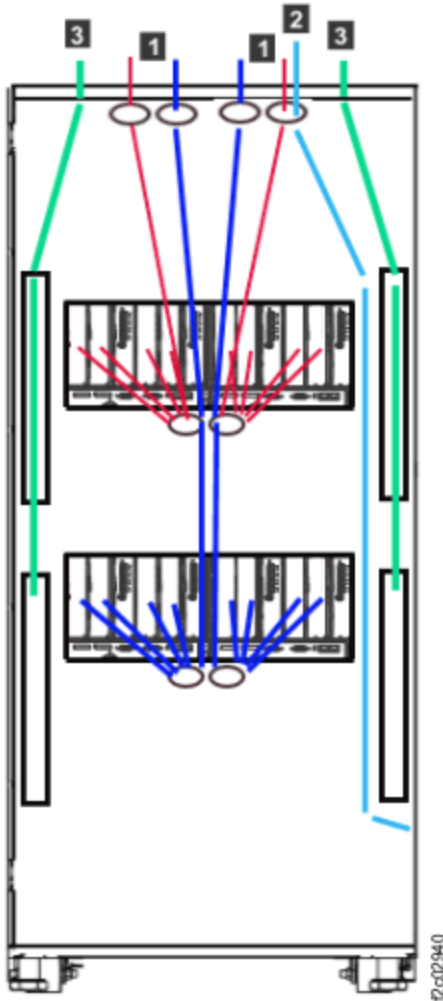

Figure 10. Top exit feature installed (cable routing and top exit locations rear view)

Feature codes for overhead cable management (top-exit bracket)

Use this feature code to order cable management for overhead cabling (top-exit bracket) for your IBM Storage DS8000 (10th Generation) Model A01, A05, or E05.

Note: In addition to the top-exit bracket, one ladder (feature code AAX0) must also be purchased for a site where the top-exit bracket for fiber cable feature is used. The ladder is used to ensure safe access when your storage system is serviced with a top-exit bracket feature installed.

Feature Code	Description
AAV1	Top exit bracket for fibre cable

Overhead cabling installation and safety requirements

Ensure that installation and safety requirements are met before your storage system is installed.

Any excess cable length must stay above the rack. There is not enough room inside of the rack to handle extra length, and excess cable might interfere with the service process, preventing concurrent repair. Consider the following specifications and limitations before you order this feature:

- In contrast to the raised-floor power cords, which have a length from the tailgate to the connector of about 4.9 m (16 ft), the length of the top exit power cords are only 1.8 m (6 ft) from the top of the storage system.
- Product safety requirements restrict the servicing of your overhead equipment to a maximum of 3 m (10 ft) from the floor. Therefore, your power source must not exceed 3 m (10 ft) from the floor and must be within 1.5 m (5 ft) of the top of the power cord exit gate. Servicing any overhead equipment higher than 3 m (10 ft) requires a special bid contract. Contact your technical service representatives for more information on special bids.
- To meet safety regulations in servicing your overhead equipment, you must purchase a minimum of one feature code 1101 for your top exit bracket feature per site. This feature code provides a safety-approved 5-foot ladder. This ladder provides technical service representatives the ability to perform power safety checks and other service activities on the top of your storage system. Without this approved ladder, technical service representatives are not able to install or service a storage system with the top-cable exit features.

Accommodating cables

You must ensure that the location and dimensions of the cable cutouts for each frame in the storage system can be accommodated by the installation location. An overhead-cable management option (top-exit bracket) is available for the IBM Storage DS8000 (10th Generation) for environments that have special planning and safety requirements.

Use the following steps to ensure that you prepare for cabling for each storage system:

1. Based on your planned storage system layout, ensure that you can accommodate the locations of the cables that exit each frame. See the following figure for the cable cutouts for the DS8000 10th generation.

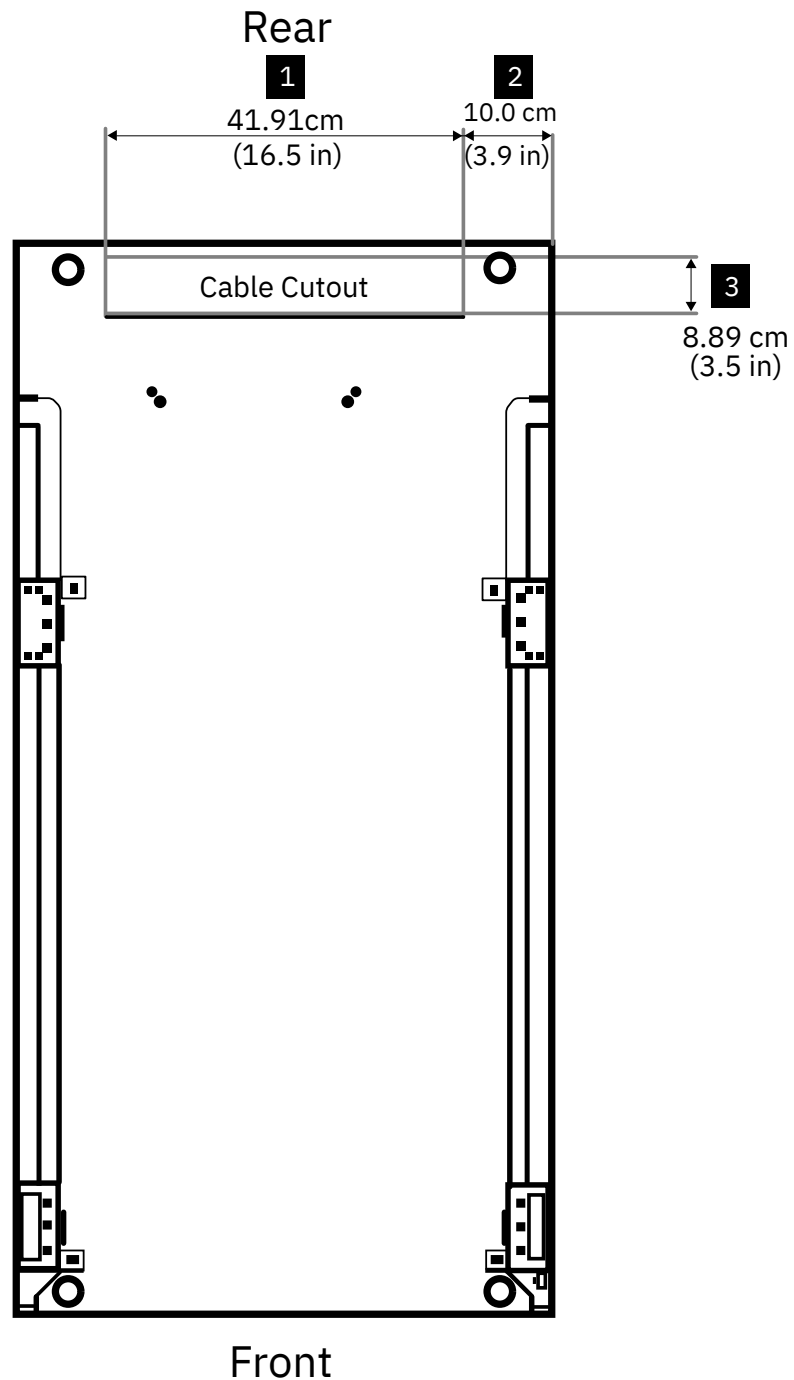

Figure 11. Cable cutouts

2. If you install the storage system on a raised floor, use the following measurements when you cut the floor tile for cabling:

- **1** Width: 41.91 cm (16.5 in)
- **2** End of frame to edge of cable cutout: 10.0 cm (3.9 in)
- **3** Depth: 8.89 cm (3.5 in)

Note: If power cord feature code 1040 is used, the depth must be at least 12 cm (4.7 in) to accommodate the power connector on the permanently attached PDU line cord.

Nonraised floors with overhead cable management

For the base frame, an option is available for overhead cabling by using the top exit bracket feature, which provides many benefits for nonraised floor installations. The cables exit the top rear middle of the rack. You can find critical safety, service, and installation considerations for this feature in [“Overhead cable management \(top-exit bracket\)”](#) on page 112.

The following figure illustrates the location of these components:

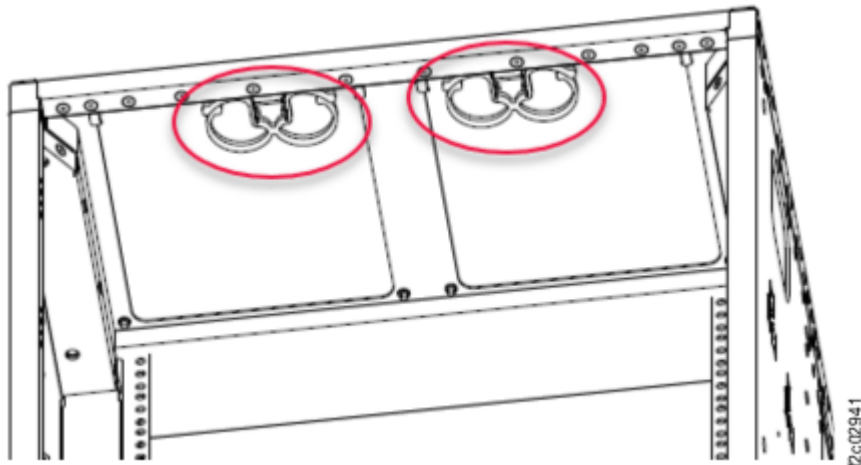

Figure 12. Top exit bracket feature

Physical footprint

The physical footprint dimensions, caster locations, and cable openings of the storage system help you plan your installation site.

The following figure shows the overall physical footprint of a storage system. The following dimensions are labeled on [Figure 13 on page 117](#)

- 1 Front service clearance
- 2 Depth of frame without covers
- 3 Width of frame without covers
- 4 Minimum dimension between casters and outside edges of frames
- 5 Leveling pads
- 6 Back service clearance
- 7 Leveling pads

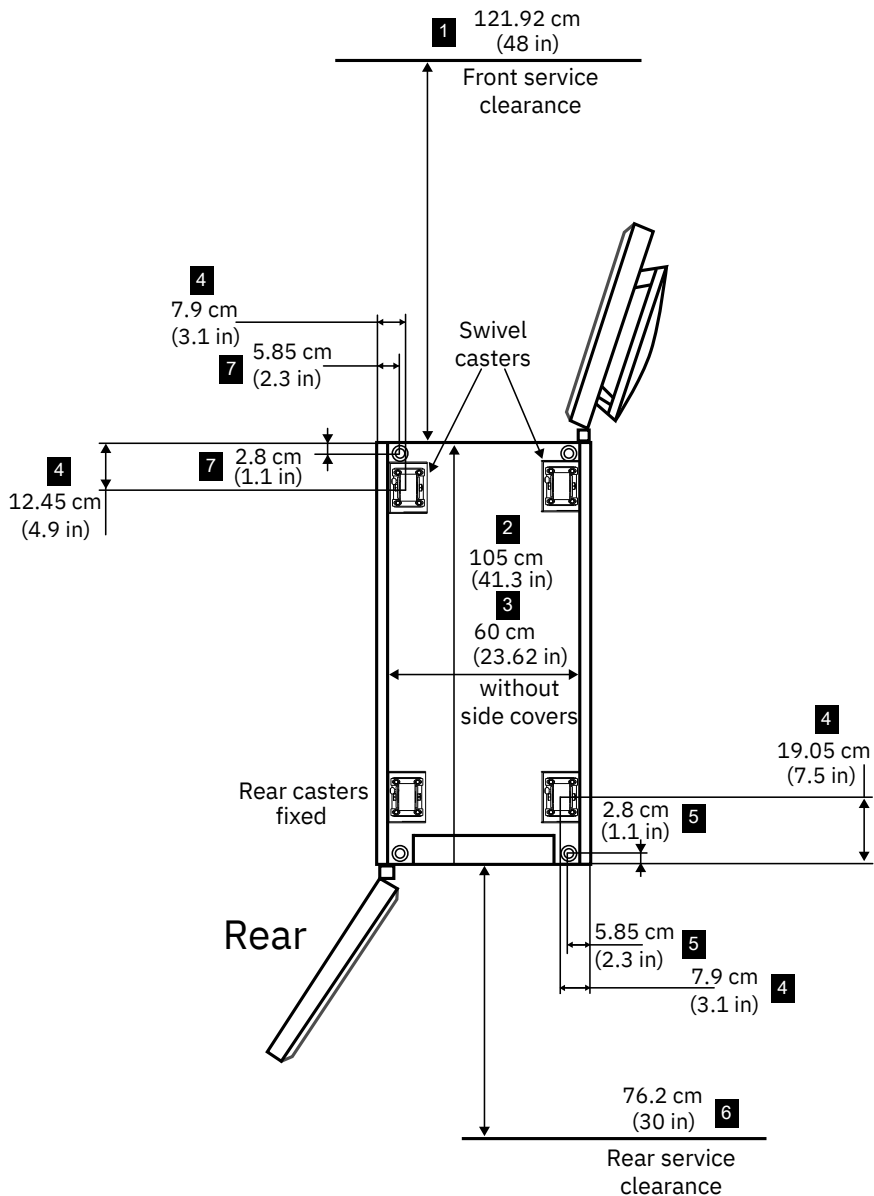

Figure 13. Physical footprint. Dimensions are in centimeters (inches).

Meeting floor load requirements

It is important for your location to meet floor load requirements.

About this task

Use the following steps to ensure that your location meets the floor load requirements and to determine the weight distribution area that is required for the floor load.

Procedure

1. Find out the floor load rating of the location where you plan to install the storage system.

Important: If you do not know or are not certain about the floor load rating of the installation site, be sure to check with the building engineer or another appropriate person.

2. Determine whether the floor load rating of the location meets the following requirements:
 - The minimum floor load rating is 342 kg per m² (70 lb. per ft²).

- Use the table to determine the required side, front, and rear weight distribution area for the specified floor load rating. The side dimensions for the weight distribution area have a maximum of 76.2 cm (30 in). If the side dimensions required to meet a specified floor load rating are greater than the maximum allowed, then the floor load rating is not listed in the table.
 - The maximum per caster weight that is transferred to a raised floor tile is 450 kg (1000 lb.).
3. Using the following table, complete these steps for each storage system.
- Find the rows that are associated with the storage system.
 - Locate the configuration row that corresponds with the floor load rating of the site.
 - Identify the weight distribution area that is needed for that storage system and floor load rating.

Note: If you are unsure about the correct placement and weight distribution areas for your storage system, consult a structural engineer.

<i>Table 41. Floor load ratings and required weight-distribution areas</i>					
Configuration _a	Total weight of configuration _b	Floor load rating, kg per m ² (lb per ft ²)	Weight distribution areas _{c, d, e}		
			Sides cm (in.)	Front cm (in.)	Rear cm (in.)
Model A01	855 kg (1885 lb)	610 (125)	22.9 (9)	76.2 (30)	76.2 (30)
		488 (100)	40.6 (16)	76.2 (30)	76.2 (30)
		439 (90)	53.3 (21)	76.2 (30)	76.2 (30)
		342 (70)	Not supported	76.2 (30)	76.2 (30)
Model A05	889 kg (1960 lb)	610 (125)	2.54 (1)	76.2 (30)	76.2 (30)
		488 (100)	10.1 (4)	76.2 (30)	76.2 (30)
		439 (90)	20.3 (8)	76.2 (30)	76.2 (30)
		342 (70)	43.1 (17)	76.2 (30)	76.2 (30)
E05	838 kg (1847.5 lb)	610 (125)	22.9 (9)	76.2 (30)	76.2 (30)
		488 (100)	40.6 (16)	76.2 (30)	76.2 (30)
		439 (90)	53.3 (21)	76.2 (30)	76.2 (30)
		342 (70)	Not supported	76.2 (30)	76.2 (30)

Notes:

- A storage system contains a base frame and any expansion frame that is associated with it.
- The base frame and expansion frame are bolted together. The weights represent a combined configuration, fully populated with all enclosures and adapters.
- Weight distribution areas cannot overlap.
- Weight distribution areas are calculated for maximum weight of the frames.

Note: Keep any future upgrades in mind, and plan for the highest possible weight distribution.

- The base and expansion frames in each storage system are bolted to each other. Move one side cover and mounting brackets from the base frame to the side of the expansion frame. Side clearance for frames that are bolted together applies to both sides of the assembled frames.

Calculating space requirements

When you are planning the installation site, you must first calculate the total amount of space that is required for the storage system. Consider future expansion, and plan accordingly.

Procedure

Complete the following steps to calculate the amount of space that is required for your storage system.

1. Determine the dimensions of each frame configuration in your storage system.
2. Calculate the total area that is needed for frame configuration by adding the weight distribution area to the dimensions determined by using the table in [“Meeting floor load requirements”](#) on page 117.
3. Determine the total space that is needed for the storage system by planning the placement of each frame configuration in the storage system and how much area each configuration requires based on step [“2”](#) on page 119.
4. Verify that the planned space and layout meet the service clearance requirements for each frame and storage system.

Dimensions and weight of individual models

When you are planning the floor and space requirements for your storage system, consider the dimensions and weights of the frames that compose your storage system.

The following [table](#) provides dimensions and weights.

Model	Dimensions ¹	Maximum weight
Model A01	42U 19-inch EIA rack Decorative door height 2.035 m (80.11 in) Decorative door width 0.616 m (24.25 in) Decorative door depth 1.24 m (48.8 in) Space saver door height 2.035 m (80.11 in) Space saver door width 0.60 m (23.62 in) Space saver door depth 1.17 m (46.06 in)	855 kg (1885 lb)
Model A05	42U 19-inch EIA rack Decorative door height 2.035 m (80.11 in) Decorative door width 0.616 m (24.25 in) Decorative door depth 1.24 m (48.8 in) Space saver door height 2.035 m (80.11 in) Space saver door width 0.60 m (23.62 in) Space saver door depth 1.17 m (46.06 in)	889 kg (1960 lb)

Table 42. IBM Storage DS8000® (10th Generation) dimensions and weights (continued)

Model	Dimensions ¹	Maximum weight
Model E05	42U 19-inch EIA rack Decorative door height 2.035 m (80.11 in) Decorative door width 0.616 m (24.25 in) Decorative door depth 1.24 m (48.8 in) Space saver door height 2.035 m (80.11 in) Space saver door width 0.60 m (23.62 in) Space saver door depth 1.17 m (46.06 in)	838 kg (1847.5 lb)

Service clearance requirements

The service clearance area is the area around the storage system that technical service representatives need to service the system.



CAUTION: Servicing of this product or unit is to be performed by trained personnel only. (C032)

For DS8000 series, technical service representatives must open the front and rear covers to service the storage system. [Figure 14 on page 121](#) illustrates related service clearance requirements:

- For the rear of the storage system **1**, allow a minimum of 76.2 cm (30.0 in.) for the service clearance.
- The length of the tailgate opening **2** on the storage system.
- For a single storage system installation (from the front of the storage system), allow a minimum of 60.96 cm (24.0 in.) on the right side **3** in the aisle to the front of the machine.
- For the front of the storage system **4**, allow a minimum of 121.9 cm (48.0 in.) for the service clearance.
- The leveling pads **5** and **6** on the storage system.
- The opening of the tailgate **7** on the storage system.

Unlike weight distribution areas that are required to handle floor loading, keep in mind that service clearances of adjacent unrelated storage systems can overlap.

Note: The terms *service clearance* and *weight distribution area* are often confused with each other. The service clearance is the area that is required to open the service covers and to pull out components for servicing. The weight distribution area is the area that is required to distribute the weight of the storage system.

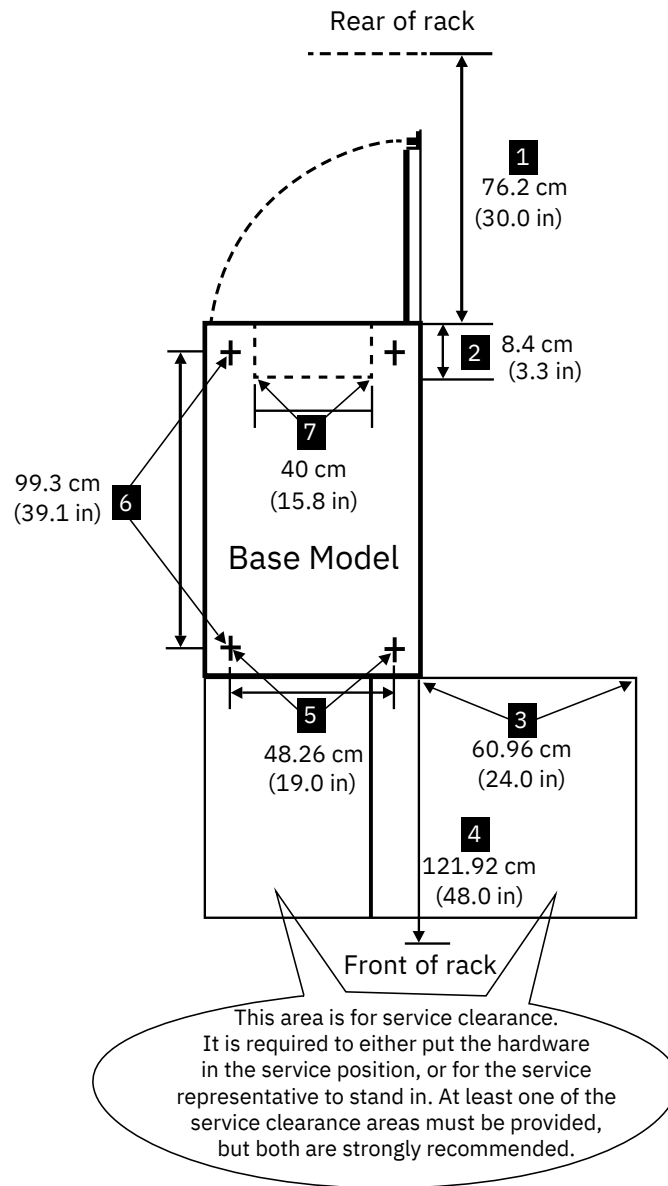

Figure 14. Service clearance requirements

Earthquake resistance kit installation preparation

Before an IBM service representative can install the earthquake resistance kit on any frames in your storage system, you must purchase fastening hardware and prepare the location where the kit is to be installed.

The required tasks that you must perform before the earthquake resistance kit installation depends on whether your storage system sits on a raised or a nonraised floor. For either type of installation, work with a consultant or structural engineer to ensure that your site preparations meet the requirements.

The following list provides an overview of the preparations necessary for each type of floor:

Raised floor

- Cut the necessary holes and cable cutouts in the raised floor.
- Purchase and install eyebolt fasteners in the concrete floor.

Nonraised floor

Purchase and install fasteners in the concrete floor.

Further instructions for the preparation of your site for the earthquake resistance kit are provided in “Preparing a raised floor for the earthquake resistance kit installation” on page 122 and “Preparing a nonraised floor for the earthquake resistance kit” on page 126.

Preparing a raised floor for the earthquake resistance kit installation

You must prepare a raised floor before an earthquake resistance kit can be installed on any frame in your storage system.

About this task

To ensure that you meet all site requirements, obtain the service of a qualified consultant or structural engineer to help you prepare the floor.

Figure 15 on page 122 and Figure 16 on page 123 illustrate the earthquake resistance kit after it is installed by an IBM service representative on a raised floor.

CONFIGURATION TABLE					
RAISED FLOOR HEIGHT 'H'	TURNBUCKLE ASM LENGTH 'L'	TURNBUCKLE ASM 'ITEM'	THREADED ROD 'A'	THREADED ROD 'B'	THREADED ROD 'C'
12.5 in TO 15.5 in	10.5 in TO 13.8 in	TURNBUCKLE SHORT	117 (11.5in)	-	-
15.5 in TO 19.0 in	13.8 in TO 17.3 in		118 (15.25in)	-	-
19.0 in TO 20.5 in	17.3 in TO 18.8 in		117 (11.5in)	116 (7.5in)	-
20.5 in TO 32.0 in	18.8 in TO 30.2 in	TURNBUCKLE LONG	119 (20in)	-	-
32.0 in TO 39.5 in	30.2 in TO 37.7 in		119 (20in)	118 (11.5in)	-
39.5 in TO 52.0 in	37.7 in TO 50.2 in		119 (20in)	116 (7.5in)	117 (11.5in)

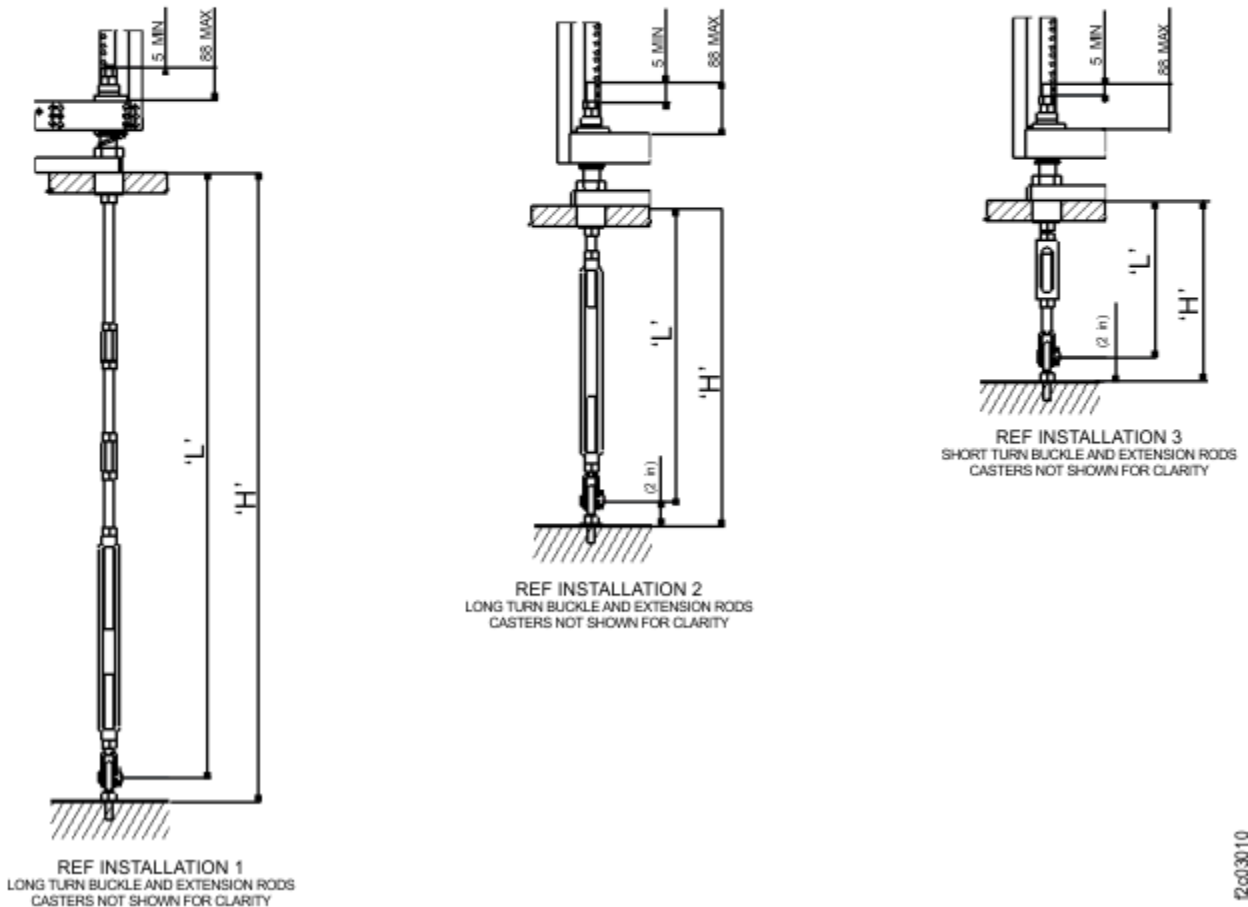

Figure 15. Turnbuckle assembly

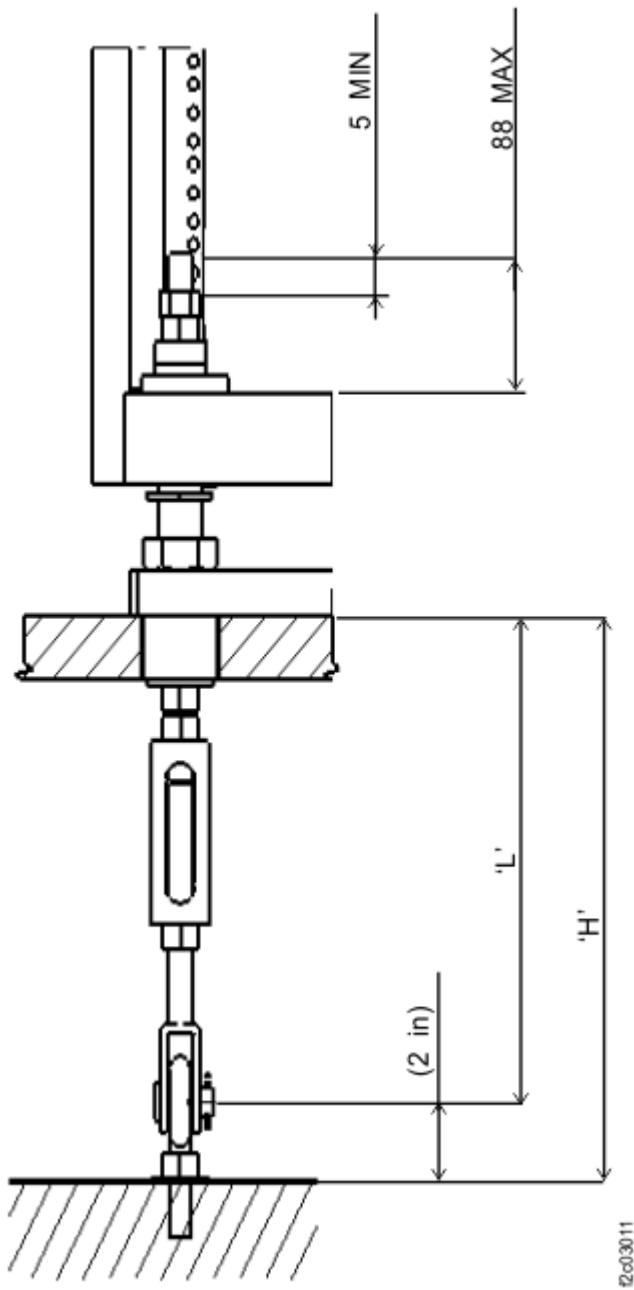

Figure 16. Earthquake resistance kit installed on a raised floor

Complete the following steps to prepare your raised floor by using [Figure 15](#) on page 122 and [Figure 16](#) on page 123 as references.

Procedure

1. Cut the following openings in the raised floor for each frame that uses an earthquake resistance kit:
 - Four holes for the rubber bushings of the kit to fit through the floor.
 - One cable cutout for power and other cables that connect to the frame.

Use [Figure 17](#) on page 124 as a guide for the location and dimensions of these openings. The pattern repeats for each frame in the configuration. Dimensions are in millimeters (inches).

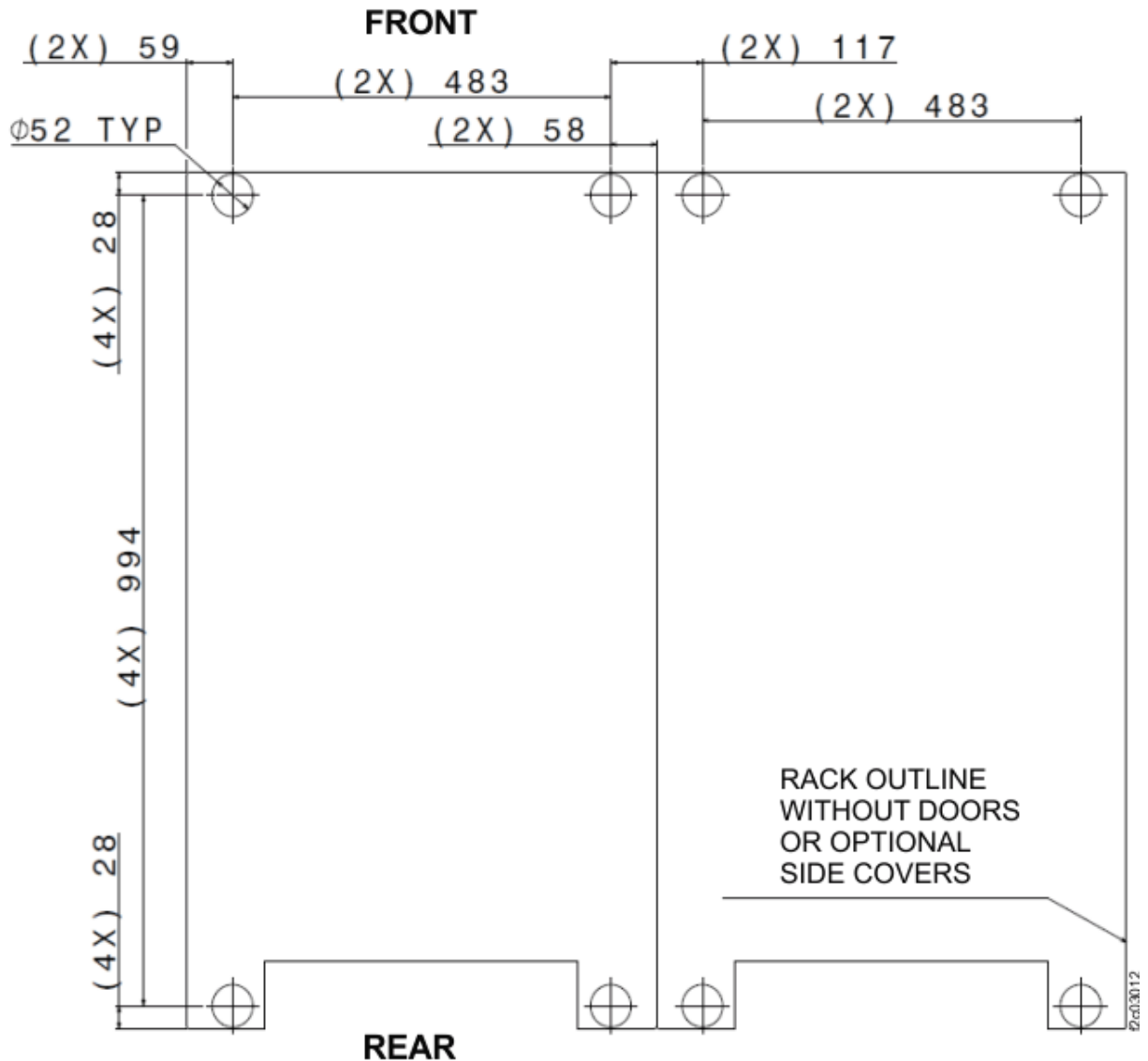
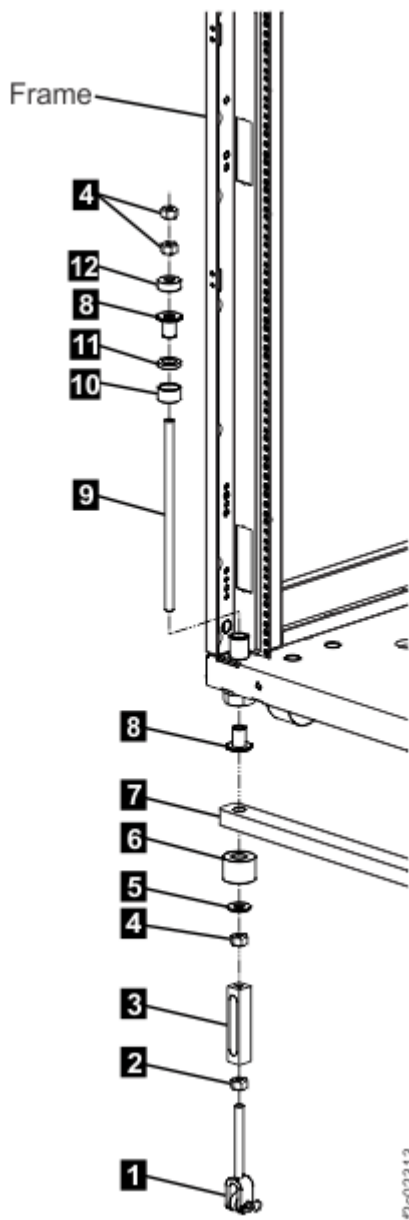

Figure 17. Locations for the cable cutouts, rubber bushing holes on raised floors, and eyebolt on concrete floors

2. Obtain four fasteners (per frame) that are heavy-duty concrete or slab floor eyebolts. The four fasteners per frame are different than the eight fasteners per frame that are needed for non-raised floor installation.

These eyebolts are used to secure the earthquake resistance kit. Work with your consultant or structural engineer to determine the correct eyebolts to use, but each eyebolt must meet the following specifications.

- Each eyebolt must withstand a 3600-pound pull force.
- The dimensions of the eyebolt must allow the turnbuckle lower jaw of the kit to fit over the eyebolt and allow the spacer of earthquake resistance kit to fit inside the eye. See [Figure 18 on page 125](#) and [Figure 19 on page 126](#).



12002313

- 1** Yoke
- 2** Nut, left-hand thread
- 3** Turnbuckle ½-13 right hand and left hand
- 4** Nut
- 5** Washer
- 6** Bushing
- 7** Load plates
- 8** Bushing, Plastic
- 9** Rods, ½-13 right hand, 304 mm, or 533 mm
- 10** Spacer
- 11** Washer flat, thick
- 12** Washer flat, custom

Figure 18. Raised floor tie-down installation

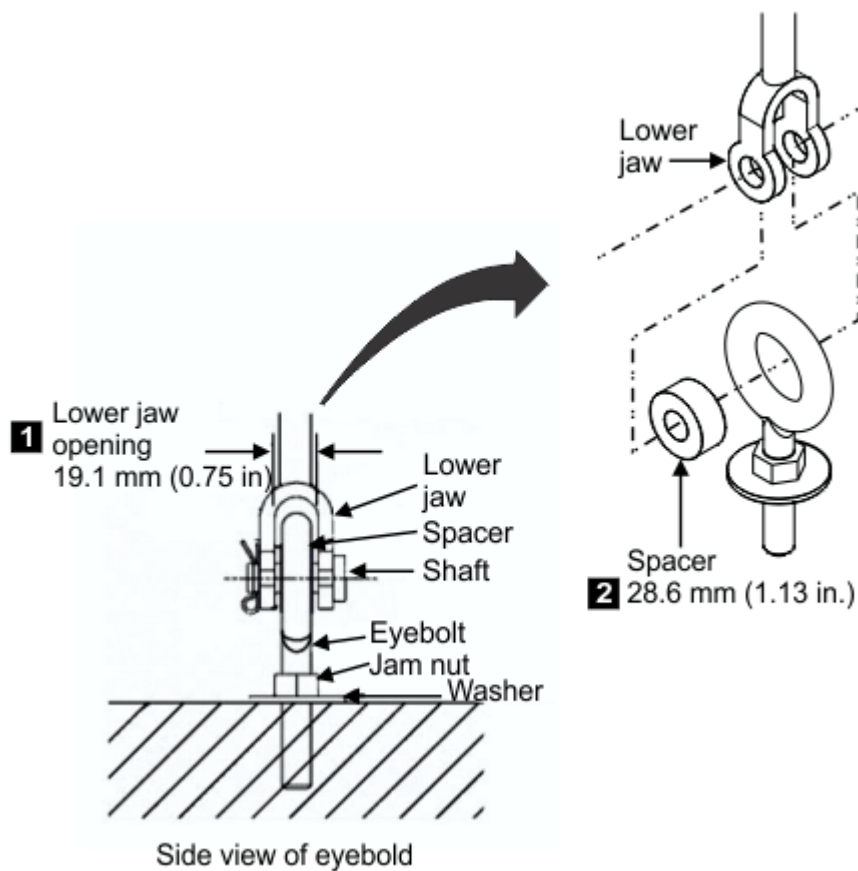

Figure 19. Eyebolt required dimensions. Dimensions are in millimeters (inches).

3. Install the eyebolt fasteners in the concrete floor by using the following guidelines:

- See [Figure 17 on page 124](#) and [Figure 19 on page 126](#) to determine the placement of the eyebolts. The eyebolts must be installed so that they are directly below the holes that you cut in the raised floor for the rubber bushings.
- Ensure that the installed eyebolts do not exceed a height of 10.1 cm (4 in.) from the floor to the center of the eye. This maximum height helps to reduce any bending of the eyebolt shaft.
- Ensure that the installation allows the eyebolts to meet the required pull force after they are installed (3600-pound pull force for raised floor eyebolts).
- If you use a threaded eyebolt that secures into a threaded insert in the floor, consider using a jam nut and washer on the shaft of the eyebolt. Talk to your consultant or structural engineer to determine whether a jam nut is necessary.

Preparing a nonraised floor for the earthquake resistance kit

You must prepare a nonraised floor before an earthquake resistance kit can be installed on any frame in your storage system.

About this task

To ensure that you meet all site requirements, obtain the service of a qualified consultant or structural engineer to help you prepare the floor.

[Figure 20 on page 127](#) provides an illustration of the earthquake resistance kit (1) after the IBM service representative installs it on the nonraised floor.

Before the IBM service representative installs the kit, you must prepare the area that is shown as (2) in [Figure 20 on page 127](#). This figure shows two of the most common fasteners that you can use.

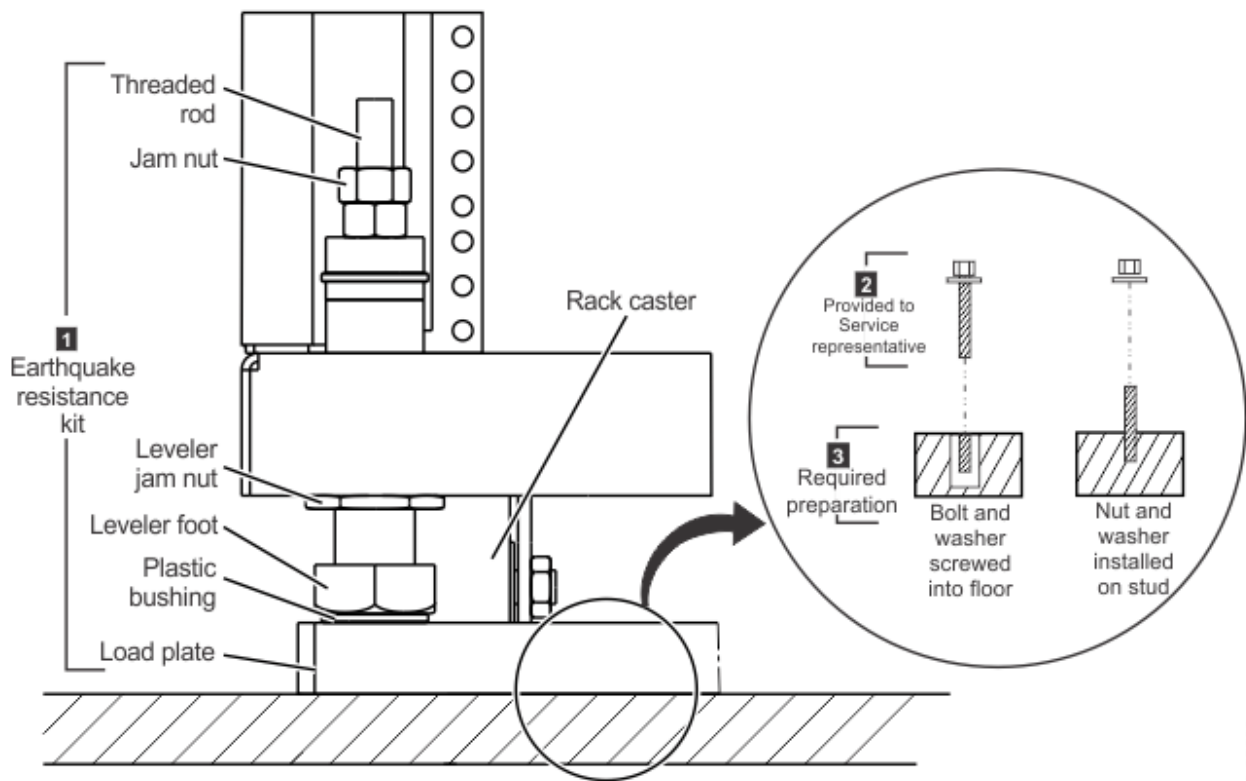

Figure 20. Earthquake resistance kit installed on a nonraised floor.

Use the following steps to prepare your nonraised floor:

Procedure

1. Obtain eight fastener sets for each frame that uses the earthquake resistance kit.

These fastener sets are used to secure the earthquake resistance kit load plate. The type of fastener set that you use can be determined by your consultant or structural engineer. However, each bolt or stud must meet the following specifications:

- Each fastener set must withstand a 2400-pound pull force.
- The fasteners must have a dimension that fits into the load plate holes, which are each 21 mm (0.826 in.) in diameter.
- The fasteners must be long enough to extend through and securely fasten a load plate that is 3.0 cm (1.2 in.) thick. The fasteners must also be short enough so that the height of the installed fastener does not exceed 6.5 cm (2.5 in.). This maximum height ensures that the fastener can fit under the frame.

The following examples provide descriptions of nonraised floor fastener sets. [Figure 20 on page 127](#) illustrates the fastener sets.

- Threaded hole insert that is secured into the concrete floor and a bolt (with a washer) that screws into the insert
 - Threaded stud that is secured into the concrete floor with a nut (with a washer) that screws over it
2. Work with your consultant or structural engineer and use the following guidelines to install the fasteners in the concrete floor:
 - Use [Figure 21 on page 128](#) to determine the placement of the loadplate fasteners (four per loadplate). The pattern repeats for each frame. Dimensions are in millimeters (mm).
 - Ensure that the installed fasteners do not exceed a height of 65 mm (2.5 in.) from the floor. This maximum height ensures that the fastener can fit under the frame.

- Ensure that the installation allows the fasteners to meet the required pull force after they are installed (2400-pound pull force).
- If you use a threaded bolt that secures into a threaded insert in the floor and the bolt extends longer than 30 mm (1.2 in.), which is the thickness of the load plate, consider using a jam nut and a washer on the shaft of the bolt so that the load plate can be secured snugly to the floor. Talk to your consultant or structural engineer to determine whether a jam nut is necessary.

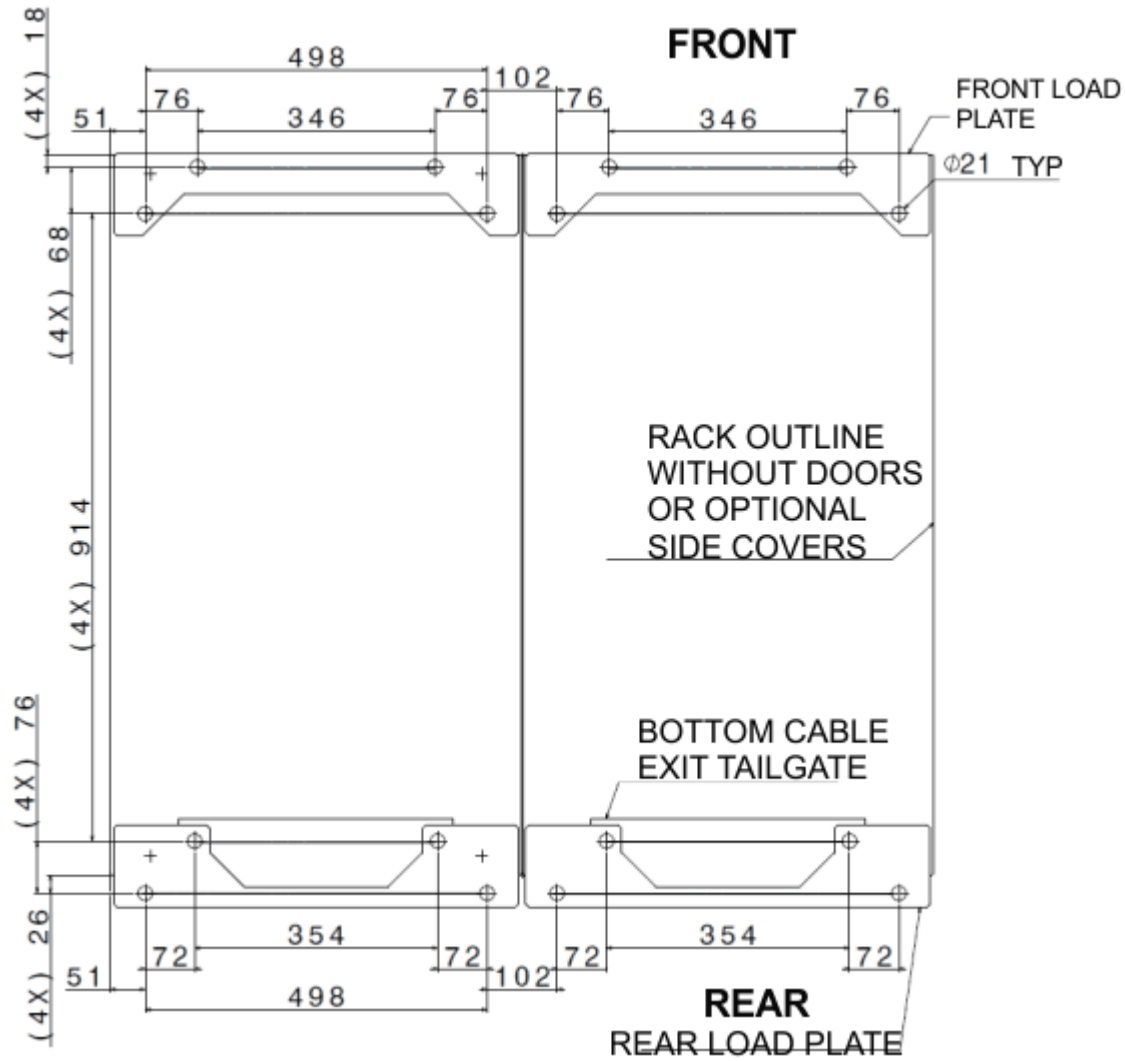

Figure 21. Location for fastener installation (nonraised floor)

3. When the IBM service representative arrives to install the earthquake resistance kit, provide the other fastener parts (2) in Figure 20 on page 127 so that the representative can use these parts secure the load plates onto the floor.

Seismic (earthquake) resistance

Seismic qualification testing was conducted on the storage system to meet ICC-ES AC-156 requirements.

Table 43 on page 129 includes the seismic test parameters and definitions.

Table 43. Seismic test parameters

	S_{DS} (g)	z/h (incl'd roof or lower levels)	HORIZONTAL (g)		VERTICAL (g)		Mounting
			A_{FLX-H}	A_{RIG-H}	A_{FLX-V}	A_{RIG-V}	
ICC-ES AC156, 2012	2.0	1.0	3.20	2.40	1.34	0.54	Raised floor and nonraised floor

Notes:

1. The earthquake resistance kit (feature code 1907) is an optional seismic kit for stabilizing the frame so that the frame complies with earthquake resistance standards.
2. Soil classes A, B, C, D, Seismic Risk Category I, II, III, IV, and Seismic Design Categories A, B, C, D, E, and F are all covered under this certification, limited by the S_{DS} value stated in column 2.
3. The following parameters are used in the table:

S_{DS}

Design spectral response acceleration at short period

z/h

Quotient of z (height of the structure with respect to attachment point) and h (average building and structure roof height regarding to the base elevation)

A_{FLX-H}

Horizontal spectral acceleration calculated for flexible components

A_{RIG-H}

Horizontal spectral acceleration calculated for rigid components

A_{FLX-V}

Vertical spectral acceleration calculated for flexible components

A_{RIG-V}

Vertical spectral acceleration calculated for rigid components

Planning for power requirements

You must select a storage system location that meets specific power requirements.

When you consider the storage system location, consider the following issues:

- Power control selections
- Power outlet requirements
- Input voltage requirements
- Power connector requirements
- Remote force power off switch requirements
- Power consumption and environment

IBM cannot install the storage system if your site does not meet these power requirements.



Attention: Implementation of surge protection for electronic devices as described in the EN 62305 standard or IEEE Emerald Book is recommended. If a lightning surge or other facility transient voltages occur, a surge-protection device limits the surge voltage that is applied at the storage system power input. A surge-protection device is required for facilities in Korea or customers that conform to the European EMC Directive or CISPR 24.

Overview of storage system power controls

The storage system contains power controls on the frames. The power controls can be configured by a technical service representative. The power controls can also be accessed through the management console.

Power outlet requirements

Plan for the required power outlets for the installation of your storage system.

Each model A01, A05, and E05 requires two or four independent power outlets for the two or four power cords. The number of power cords is determined by the size of the configuration. The model A05 and model E05 expansion frame requires two power outlets and cords. Note that each power feature provides a pair of cords.

Important: To avoid a single point of failure, the frames require two independent power feeds. One power source feeding the power cords on the right side of the frame, and the other source feeding the power cords on the left side of the frame.



Attention: Ensure that there is a local site disconnect and/or isolation means (such as a service branch circuit breaker, power feed switch, and/or wall socket outlet to an industrial style plug) for each AC main power cord to a system. The internal rack (system side) appliance cord coupler is NOT intended to be connected or disconnected live. Follow local electrical authority site regulations for proper isolation practices such as Lock Out Tag Out (LOTO) and/or approved procedures.



CAUTION: No Live Plugging. Appliance coupler (machine connector end) of line cord is not intended for electrically live (hot) plugging nor for interrupting current (disconnecting under load). Isolate input power to the identified cord from the service branch circuit. Whenever attaching, unplugging, or leaving the plug disconnected, remove voltage by unplugging the wall end of that cord, or by turning off the breaker or the switch for that cord.



Input voltage requirements

When you plan for the power requirements of the storage system, consider the input voltage requirements.

The following table provides the input voltages and frequencies that the storage system supports.

Characteristic	Voltage (single-phase)
Nominal input voltages	Feature code AAS0: 200 - 208 RMS V AC
	Feature codes AAS1, AAS4, and AAS5: 200 - 240 RMS V AC
	Feature code AAS6: 200 - 230 RMS V AC
Minimum tolerated input voltage	180 RMS V AC
Maximum tolerated input voltage	256 RMS V AC
System maximum current rating	24/32 Amps (per PDU cord)

Table 44. Single-phase input voltages and frequencies (continued)

Characteristic	Voltage (single-phase)
Wall breaker rating (1 ph)	Feature codes AAS0, AAS5: 30 A
	Feature codes AAS1, AAS6: 30 A - 32 A
	Feature code AAS4: 32 A
Steady-state input frequencies	50 ± 3 or 60 ± 3.0 Hz
PLD input frequencies (<10 seconds)	50 ± 3 or 60 ± 3.0 Hz

Table 45. Three-phase input voltages and frequencies

Characteristic	Three-phase delta (3ØΔ)	Three-phase wye (3ØY: LL[Line-to-Line])
Nominal input voltages	200 - 240 RMS V AC	380, 400, or 415 RMS V AC
Minimum tolerated input voltage	180 RMS V AC	315 RMS V AC
Maximum tolerated input voltage	256 RMS V AC	456 RMS V AC
System maximum current rating	48 Amps (per PDU cord)	32 Amps (per PDU cord)
Wall breaker rating (3 ph)	60 - 63 Amps	30 - 32 Amps
Steady-state input frequencies	50 ± 3 or 60 ± 3.0 Hz	50 ± 3 or 60 ± 3.0 Hz
PLD input frequencies (<10 seconds)	50 ± 3 or 60 ± 3.0 Hz	50 ± 3 or 60 ± 3.0 Hz

Power connector requirements

Ensure that the site where you plan to install the storage system meets the power connector requirements.

Table 46 on page 131 shows the power cords and the inline connectors and receptacle types that they support. Find the power cord row that is appropriate for your site. Ensure that your site meets the specified power connector requirements.



Attention:

- For reliable operation do not use Ground Fault Circuit Interrupter (GFCI), Earth Leakage Circuit Breaker (ELCB), or Residual Current Circuit Breaker (RCCB) type circuit breakers with the DS8A00. The DS8A00 is certified for safe operation and compliant with IEC, EN, UL, and CSA 60950-1 standards. If local electrical practice requires leakage detection circuit breakers, they must be rated at minimum to 30 mA or larger to reduce the risk of outage due to spurious actuation.
- Do not exceed the wire rating of the facility and ensure that separate protected branch circuits are used for each cord in planning for redundancy.

Table 46. DS8A00 power cords

Power cord feature code	Power cord description ₆	Inline connector/ Receptacle	Wire gauge
AAS0	Single-phase power cord, 208 V, 30 A, NEMA L6-30P	NEMA L6-30P/NEMA L6-30R	10 AWG

Table 46. DS8A00 power cords (continued)

Power cord feature code	Power cord description ₆	Inline connector/ Receptacle	Wire gauge
AAS1	Single-phase power cord, 200 - 240 V, 30 A/32 A, IEC 60309	332P6W/332R6W	4 mm ²
AAS3	Three-phase Wye power cord, 220 - 240 V (line to neutral (LN)) / 380 V - 415 V (nominal line-to-line (LL)), 30 A/32 A, IEC 60309 (five-pin 3+N+PE)	532P6W/532R6W	4 mm ²
AAS4	Single-phase power cord, 250 V, 32 A, for use in Australia and New Zealand	56P332/56CV332	4 mm ²
AAS5	Single-phase power cord, 250 V, 30 A, for use in Korea	KP 32A/KP	4 mm ²
AAS6	Single-phase power cord, 200 - 240 V, 30 A/32 A, IEC 60309 (halogen free)	332P6W/332R6W	4 mm ²
AAS2	Three-phase Delta power cord, 200 - 240 V, 60 A/63 A, IEC 60309 (four-pin 3+PE)	460P9W/460R9W	6 AWG

Notes:

1. Power cords that are used with DS8100, DS8300, DS8700, DS8800, DS8870, DS8880, and DS8900 cannot be used again with the DS8A00.
2. Power cords without inline connectors are rated at 600 V AC. Other power cords are rated as described in the table. Single-phase power cord has 2W+G configuration.
3. Power cords that exit the bottom are 4.2 m (14 ft) from the lowest point where they exit the frame to the mating face of the plug. Power cords that exit the top are 1.8 m (6 ft) from the highest point from the frame to the mating face of the plug.
4. The IEC60309 receptacle must be installed in a metal-backed box with the green wire ground-connected to the grounding lug within the box. Ensure continuity between the box and the metallic shielding of the liquid-tight conduit.
5. The descriptions indicate the line cord rating and are not an indication of system power rating. The cord rating defines the maximum breaker rating for the line cord (60A with connector, 63A without connector). Downstream components are designed for fault currents consistent with facility circuit breaker ratings up to 63A.

Power consumption and environmental information

When you are planning to meet the power requirements for the DS8A00 series, consider the power consumption and other environmental points of the storage system.

The power consumption and environmental information for the DS8A00 is provided in [Table 47 on page 132](#).

Table 47. Power consumption and environmental information for models A01, A05, and E05.

Measurement	Unit of measure	Base frame	Expansion frame
Peak electric power ^{1, 2}	Kilowatt (kW)	Model A01: ≤ 10.2 Model A05: ≤ 10.2	Model E05: ≤ 10.2

Table 47. Power consumption and environmental information for models A01, A05, and E05. (continued)

Measurement	Unit of measure	Base frame	Expansion frame
Thermal load	British thermal units (BTU) per hour	≤ 34800	≤ 34800
Capacity of exhaust	cubic meters per minute (cubic feet per minute or CFM)	44.2 (1500)	51.8 (1800)
Ground leakage current	milliamperes (mA)	< 26.1	< 26.1
Startup current	amperes (A or amp)	≤ 100	≤ 100
Startup current duration	microseconds (μs or μsec)	< 200	< 200

Notes:

- The values represent data obtained from typical systems, which are configured as follows:
 - Model A01, A05, or E05 that contains four fully configured High Performance Flash Enclosure Gen3 pair and 16 Fibre Channel adapters.
- All frames and configurations that are used in single-phase mode must not exceed 8 kVA.

Acoustic declaration

Table 48 on page 133 describes the acoustic declaration information for the storage system.

Table 48. Acoustic declaration for fully configured storage system

Model	Declared mean A-weighted sound power level, LWA,m (B)		Declared mean A-weighted emission sound pressure level, LpA,m (dB)		Statistical Adder for verification Kv (B)	
	Operating	Idling	Operating	Idling	Operating	Idling
Model A01, and A05	8.3	8.3	76	76	0.3	0.3
Model E05	8.3	8.3	76	76	0.3	0.3

Table 48. Acoustic declaration for fully configured storage system (continued)

Model	Declared mean A-weighted sound power level, LWA,m (B)		Declared mean A-weighted emission sound pressure level, LpA,m (dB)		Statistical Adder for verification Kv (B)	
	Operating	Idling	Operating	Idling	Operating	Idling
<p>Notes:</p> <ol style="list-style-type: none"> 1. Declared level LWA,m is the mean A-weighted sound power level. 2. Declared level LpA,m is the mean A-weighted sound pressure level computed as the arithmetic average of the measurements at the 1-meter bystander positions, or it is measured as the maximum 0.5-meter operator position at the front or rear face with the doors opened. 3. The statistical adder for verification, Kv, is a quantity to be added to the declared mean A-weighted sound power level, LWA,m such that there will be a 95% probability of acceptance, when using the verification procedures of ISO 9296, if no more than 6.5% of the batch of new equipment has A-weighted sound power levels greater than ($LWA,m + Kv$). 4. The quantity LWA,c (formerly called $LWAd$), can be computed from the sum of LWA,m and Kv. 5. Measurements are made in conformance with ISO 7779 and declared in conformance with ISO 9296. 6. B, dB, abbreviations for bels and decibels, respectively. 1 B = 10 dB. 7. Under certain environments, configurations, system settings and/or workloads, fan speeds are increased resulting in higher noise levels. <p>Notice: Government regulations (such as those prescribed by OSHA or European Community Directives) may govern noise level exposure in the workplace and may apply to you and your server installation. The actual sound pressure levels in your installation depend upon a variety of factors, including the number of racks in the installation; the size, materials, and configuration of the room where you designate the racks to be installed; the noise levels from other equipment; the room ambient temperature, and employees' location in relation to the equipment. Further, compliance with such government regulations also depends upon a variety of additional factors, including the duration of employees' exposure and whether employees wear hearing protection. IBM recommends that you consult with qualified experts in this field to determine whether you are in compliance with the applicable regulations.</p>						

Planning for environmental requirements

You must install your storage system in a location that meets the operating environment requirements for correct maintenance.

Take the following steps to ensure that you meet these requirements:

1. Verify that you can meet the environmental operating requirements at the air intake locations at the front of the rack.
2. Consider optimizing the air circulation and cooling for the storage system by using a raised floor, adjusting the floor layout, and adding perforated tiles around the air intake areas.

Fans and air intake areas

The storage system provides front to rear air circulation through fans internal to each enclosure and power supply. You must maintain the correct operating environment requirements for your models at each air intake location.

Operating environment requirements

You must meet specific operating environment requirements at all the air intake locations of your storage system.

The operating points vary depending on the state of the system. The system can be in the following states:

- Powered on
- Powered off
- In storage

Powered on

Plan for the operating ranges and recommended operating points of the storage system.

Table 49 on page 135 provides the operating ranges for your storage system when its power is on.

<i>Table 49. Operating extremes with the power on</i>	
Measurement	Value
Altitude	0 - 2133 m (0 - 7000 ft)
Dry bulb temperature	16 - 32°C (60 - 90°F)
Relative humidity	20 - 80%
Wet bulb temperature (maximum)	23°C (73°F)

Table 50 on page 135 provides the optimum operating points for your storage system with its power on.

<i>Table 50. Optimum operating points with the power on</i>	
Measurement	Value
Temperature	22°C (72°F)
Relative humidity	45%

Table 51 on page 135 provides the operating ranges for a storage system with power on.

<i>Table 51. Optimum operating ranges with power on</i>	
Measurement	Value
Temperature	16 - 32°C (60 - 90°F)
Relative humidity	40 - 50%

Powered off

Plan for the required temperature and humidity ranges when the storage system is off.

Table 52 on page 135 provides the temperatures and humidity requirements for your storage system when the power is off.

<i>Table 52. Temperatures and humidity with the power off</i>	
Measurement	Value
Temperature	10 - 43°C (50 - 110°F)
Relative humidity	8 - 80%
Wet bulb temperature (maximum)	27°C (80°F)

In storage

Plan for the required temperature and humidity ranges when the storage system is in storage.

Table 53 on page 136 provides the temperatures and humidity requirements for storing your storage system.

<i>Table 53. Temperatures and humidity while in storage</i>	
Measurement	Value
Temperature	1 - 60°C (34 - 140°F)
Relative humidity	5 - 80%
Wet bulb temperature (maximum)	29°C (84°F)

Corrosive gasses and particulates

Plan for air quality that meets standards for corrosive gases and particulates.

The storage system is designed to operate reliably in a general business-class environment. A general business-class environment is one that has automated 24x7x365 temperature and humidity controls and also operates with G1 specifications for corrosive gases and P1 specifications for particulates.

Operating vibration and shock requirements

The vibration levels that are designed for the storage system comply with class V1 requirements included in the product classes for vibration.

The storage system is designed to operate under the vibration V1 levels that are described in [Table 54](#) on [page 136](#). Additional information includes random vibration PSD profile breakpoints and operational shock levels. See [Table 55](#) on [page 136](#) and [Table 56](#) on [page 136](#).

<i>Table 54. Vibration levels</i>		
Class	grms	g Peak Sine ^{1, 2}
V1L	0.10	0.06 @ 50 and 60 Hz
Notes:		
1. All values in this table are in g^2/Hz		
2. g is the peak g level of an approximate half-sine pulse.		

<i>Table 55. Random vibration PSD profile breakpoints</i>									
Class	5 Hz	17 Hz	45 Hz	48 Hz	62 Hz	65 Hz	150 Hz	200 Hz	500 Hz
V1L	2.0×10^{-7}	2.2×10^{-5}	2.2×10^{-5}	2.2×10^{-5}	2.2×10^{-5}	2.2×10^{-5}	2.2×10^{-5}	2.2×10^{-5}	2.2×10^{-5}
Note: All values in this table are in g^2/Hz .									

<i>Table 56. Operational shock levels</i>			
Class	Axis	g^1	pw^2
S1	Vertical	3.5	3.0
Notes:			
1. g is the peak g level of an approximate half-sine pulse.			
2. "pw" is the pulse width in milliseconds.			

Contamination information

You must consider the air quality and contamination levels at your installation site.

Airborne particulates (including metal flakes or particles) and reactive gases that act alone or in combination with other environmental factors, such as humidity or temperature, might pose a risk to the storage system hardware. Risks that are posed by the presence of excessive particulate levels or concentrations of harmful gases include damage that might cause the system to malfunction or cease functioning altogether. This specification presents limits for particulates and gases that are intended to avoid such damage. The limits must not be viewed or used as definitive limits because numerous other factors, such as temperature or moisture content of the air, can influence the impact of particulates or environmental corrosives and gaseous contaminant transfer.



Attention: In the absence of specific limits that are presented in this document, you must implement practices that maintain particulate or gas levels that are consistent with the protection of human health and safety. If it is determined that the levels of particulates or gases in your environment damaged the storage system, the warranty is void. Implementation of correctional measures is a customer responsibility.

The following criteria must be met:

Gaseous contamination

Severity level G1 according to ANSI/ISA 71.04-1985¹, which states that the reactivity rate of copper coupons must be fewer than 300 Angstroms per month ($\text{\AA}/\text{month}$, $\approx 0.0039 \mu\text{g}/\text{cm}^2\text{-hour weight gain}$)². In addition, the reactivity rate of silver coupons must be less than $300\text{\AA}/\text{month}$ ($\approx 0.0035 \mu\text{g}/\text{cm}^2\text{-hour weight gain}$)³. The reactive monitoring of gaseous corrosivity is conducted approximately 2 inches (5 cm) in front of the rack on the air inlet side at one-quarter and three-quarter frame height off the floor, or where the air velocity is much higher.

Particulate contamination

Data centers must meet the cleanliness level of ISO 14644-1 class 8. For data centers without airside economizers, the ISO 14644-1 class 8 cleanliness can be met by selecting one of the following filtration methods:

- The room air can be continuously filtered with MERV 8 filters.
- Air entering a data center can be filtered with MERV 11, or preferably MERV 13 filters.

For data centers with airside economizers, the choice of filters to achieve ISO class 8 cleanliness depends on the specific conditions present at that data center. The deliquescent relative humidity of the particulate contamination must be more than 60% RH⁴. Data centers must be free of zinc whiskers⁵.

1. ANSI/ISA-71.04.1985. *Environmental conditions for process measurement and control systems: Airborne contaminants*. Instrument Society of America, Research Triangle Park, NC, 1985.
2. The derivation of the equivalence between the rate of copper corrosion product thickness growth in $\text{\AA}/\text{month}$ and the rate of weight gain assumes that Cu_2S and Cu_2O grow in equal proportions.
3. The derivation of the equivalence between the rate of silver corrosion product thickness growth in $\text{\AA}/\text{month}$ and the rate of weight gain assumes that Ag_2S is the only corrosion product.
4. The deliquescent relative humidity of particulate contamination is the relative humidity at which the dust absorbs enough water to become wet and promote corrosion, ion migration, or both.
5. Surface debris is randomly collected from 10 areas of the data center on a 1.5 cm diameter disk of sticky, electrically conductive tape on a metal stub. If examination of the sticky tape in a scanning electron microscope reveals no zinc whiskers, the data center is considered free of zinc whiskers.

Cooling the storage complex

You can take steps to optimize the air circulation and cooling for your storage systems.

About this task

To optimize the cooling around your storage systems, prepare the location of your storage systems as recommended in the following steps.

Note: The installation of a storage system is done by technical service representatives. However, the following steps describe the process that is needed to optimize the air circulation and cooling prior to installation.

1. Prepare for the installation of the storage system on a raised floor. Although the storage system can be installed on a nonraised floor, installing the storage system on a raised floor provides increased air circulation for better cooling.
2. Install perforated tiles in the front of each base frame and expansion frame as follows:
 - a. For stand-alone base frames, install two fully perforated tiles in front of each base frame, as shown in [Figure 22 on page 139](#) in the single-machine examples (1 and 2 in the figure).
 - b. For a row of storage systems, install a row of perforated tiles in front of the storage systems as shown in [Figure 22 on page 139](#) (3 in the figure).
 - c. For groupings of storage systems, where a hot aisle/cold aisle layout is used, use a cold aisle row of perforated tiles in front of all storage systems. An example of a possible minimal arrangement is shown in [Figure 22 on page 139](#) (4 in the figure).

Note: Keep in mind that the example represented in [Figure 22 on page 139](#) meets service clearance requirements. However, floor loading requirements might require a wider hot aisle to provide up to 30 inches of non-overlapping clearance (for total of 60 inches between the rear side of the frames on either side of the aisle.)

F = front Base = Base model
 R = rear Exp = Expansion model

 2 ft tile  2 ft perforated tile

Single Machine - 2 examples

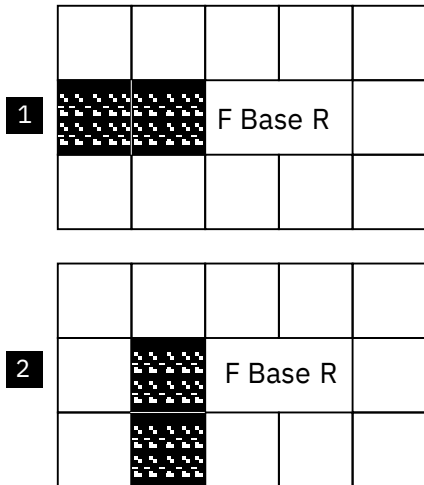

Row of Machines - 1 example

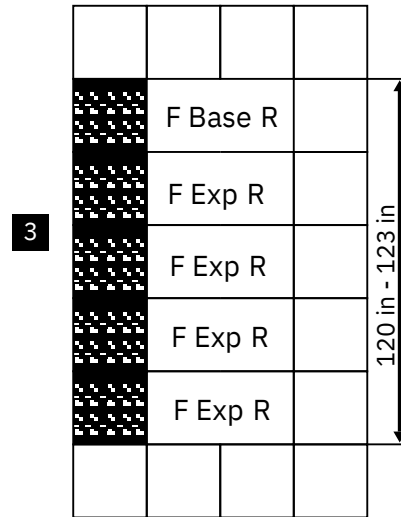

Hot Aisle / Cold Aisle installation

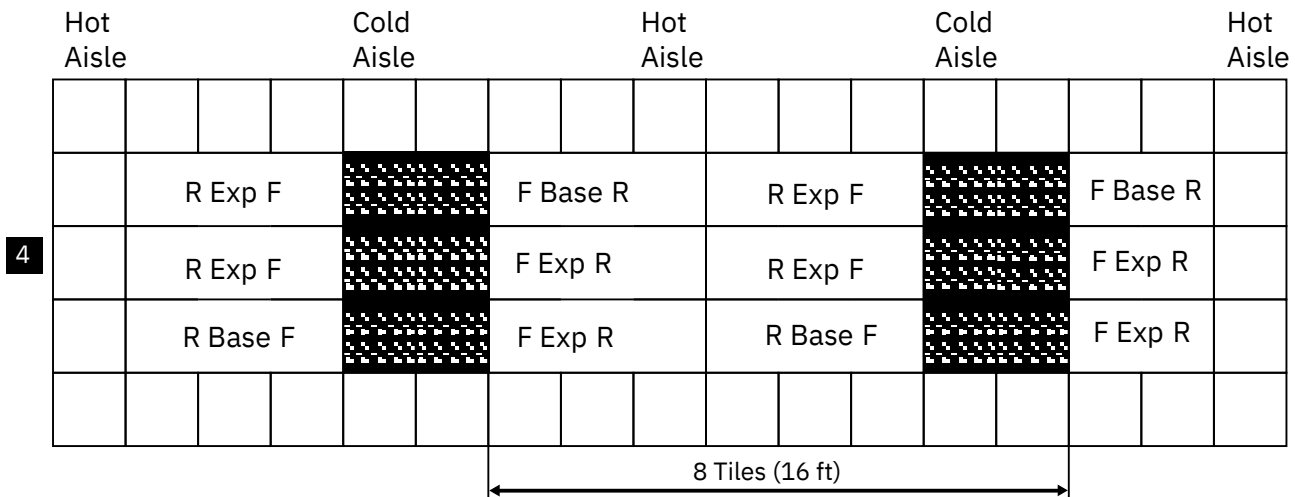

Figure 22. Typical rack and perforated tile locations for hot and cold aisles

Planning for safety

You must consider various safety issues when you plan your storage system location.

The following list identifies some of the safety issues you must consider:

- Fire suppression
- Earthquake safety

Providing service navigation equipment

You are responsible for providing appropriate service equipment for your storage system.

The storage system requires two service representatives to install at your site because of the weight of the components. You must provide the installation safety equipment based on the position of the components in your frame.

<i>Table 57. Safety equipment</i>	
Feature code	Description
AAX0	Overhead ladder - 5 ft
AAX1	Kick step

Providing a fire-suppression system

Set up an environment that supports the temperature, cooling, and operating requirements of your storage system. You are responsible for providing a fire suppression system for your storage system.

About this task

Because IBM does not test any equipment for compatibility with fire-suppression systems, IBM does not make compatibility claims of any kind. IBM does not provide recommendations on fire-suppression systems.

Procedure

1. Consult your insurance underwriter, local fire marshal, or local building inspector about selecting a fire-suppression system that provides the correct level of coverage and protection.
2. Set up an environment that supports the temperature and cooling requirements for your storage system as described in the environmental temperature requirements-planning area.

Earthquake preparedness alternatives

If you are installing your storage system in an area that is prone to earthquakes, plan for special installation methods to minimize earthquake damage to your system.

An unsecured base or expansion frame can topple or be displaced during an earthquake. This displacement puts both the storage system and your personnel in danger. To help prevent damage, restrain your storage system by using one of the following two methods:

Restraint method

Allows some system movement and provides for both personnel safety and protection of your storage system. The DS8000 earthquake resistance kit provides this type of earthquake protection.

Hard mounting

Physically attaches your system to the floor. This method increases the safety of personnel during an earthquake. However, the method damages the storage system because the system absorbs most of the shock. IBM does not support hard mounting.

Planning for network and communications requirements

You must locate your storage systems in a location that meets the network and communications requirements.

Keep in mind the following network and communications issues when you plan the location and interoperability of your storage systems:

- Management console network requirements
- Remote power control requirements
- Host attachment requirements
- SAN considerations

Management console network requirements

You must plan for the network requirements of the management console.

Each management console requires a dedicated connection to the network. Each management console provides two network connections, a primary and a secondary.

Note: If you plan on accessing the DS CLI or DS8000 Storage Management GUI and have a firewall between the management console and your network, open the following TCP/IP ports before installation: 1750, 1751, 1755 for CLI, and 8452 for the DS8000 Storage Management GUI.

Remote support connection requirements

IBM highly recommends remote-support connections so that the storage system can report failures and transmit pertinent debugging data to product support teams.

When call home is used, your technical support representative can be immediately notified to quickly isolate and resolve potential issues with the storage system. The strategic and preferred remote support connectivity method for call home is internet SSL (Secure Socket Layer) for management console communication.

For remote access to the management console and the storage system, the preferred remote support connectivity method is Assist On-site (AOS). AOS provides a network-type connection that is secured by SSL and state-of-the-art encryption technology. If your security guidelines allow, AOS can be turned on and configured on the management console, which is the preferred implementation. Alternatively, AOS is installed on a PC that you provide and maintain. Contact your technical support representative for more details.

In addition to AOS, IBM also offers remote support center (RSC). It is a simple SSH proxy based remote service solution that can be used if AOS does not meet your security guidelines. Contact your technical service representative for more information on RSC.

Remote support must be ready at the time of the initial installation of the DS8000. It is tested as part of the verification process that the installation is complete and ready for customer use. For internet-based remote support, you must open your firewalls.

Remote power control requirements

Use the remote power control settings to control the power of your storage complex. Settings can be controlled through the DS8000 Storage Management GUI running on the management console.

There are several settings for remote power control.

Host attachment communication requirements

Use host attachment communication requirements information to connect the host attachments in your network.

- You must use worldwide port names to uniquely identify Fibre Channel adapters that are installed in your host system.
- For open-system hosts with Fibre Channel adapters, keep in mind that Fibre Channel architecture provides various communication protocols. Each interconnected storage system within the architecture is referred to as a *node*, and each host is also a node. Each node corresponds to one or more ports. (In the case of Fibre Channel I/O adapters, these ports are Fibre Channel ports.) Each port attaches to a serial-transmission medium that provides duplex communication with the node at the other end of the

medium. You can configure your network structure that is based on one of three basic interconnection topologies (network structures):

- Point-to-point and switched fabric
- Fibre Channel (FICON). This connection does not apply to open systems.

See the *IBM DS8000 Host Systems Attachment Guide* for more information about these supported topologies.

- The maximum distance between a shortwave host adapter Fibre Channel port and the following network components is 380 meters (1,246 ft 9 in.) at 4 Gbps, 150 meters (492 ft 2 in.) at 8 Gbps, and 100 meters (328 ft 1 in.) at 16 Gbps. For a longwave host adapter Fibre Channel port, the maximum distance is 10 km (6.2 miles).
 - Fabric switches
 - Fabric hubs
 - Link extenders
 - Storage system Fibre Channel port

The maximum distance might be greater than 10 km (6.2 miles) when a link extender provides target initiator functions or controller emulation functions.

Note: Do not use link extenders with emulation functions on links over which Remote Mirror and Copy operations are performed. Link extenders with emulation functions introduce more path delay.

- Because the Fibre Channel architecture allows any channel initiator to access any Fibre Channel device, without access restrictions, a security exposure can occur. Have your technical service representative set the Fibre Channel access modes to the correct setting. See the *IBM DS8000 Host Systems Attachment Guide* for more information about Fibre Channel access modes.
- Storage systems can connect to IBM SAN Volume Controller host systems. See the *IBM DS8000 Host Systems Attachment Guide* for more information.



Attention: Signal-loss tolerance for single mode Fibre Channel links that run at 8 or 16 Gbps are reduced by -1.4 dB as compared to links that run at 4 Gbps. Signal-loss tolerance for Fibre Channel links that run at 32 Gbps are only slightly reduced (~-0.2 dB) as compared to links that run at 16 Gbps. Take necessary steps to ensure that links are within the signal-loss parameters that are listed when you plan a move from 4 Gbps FC to 8, 16, or 32 Gbps FC adapters with existing infrastructure. Using more than two patch panels or other link connectors between two 8, 16, or 32 Gbps ports at maximum distance of 10 km might result in greater link loss than is acceptable. Signal loss tolerance with measurements, including all connectors and patch panel connections, are:

- Loss per 10 km for 32 Gbps speed is -6.21 dB.
- Loss per 10 km for 16 Gbps speed is -6.4 dB.
- Loss per 10 km for 8 Gbps speed is -6.4 dB.
- Loss per 10 km for 4 Gbps speed is -7.8 dB.

OS1 or OS2 single mode Fibre Channel cables are supported for longwave adapters.

OM3 or OM4 (recommended) multimode Fibre Channel cables are required to support 16 and 32 Gbps host adapters.

Chapter 7. Planning your storage complex setup

During installation, IBM customizes the setup of your storage complex that is based on information that you provide in the configuration worksheets.

Each time that you install a new storage system or management console, you must complete the configuration worksheets before installation by technical service representatives.

Use the configuration worksheets at IBM Techdocs (<http://www.ibm.com/support/techdocs/atsmastr.nsf/WebIndex/PRS4743>) to specify the initial setup for the following items:

- Company information
- Management console network settings
- Remote support (includes call home and remote service settings)
- Notifications (includes SNMP trap and email notification settings)
- Control Switch settings

Important: Technical service representatives cannot install a storage system or management console until you provide them with the completed configuration worksheets.

Company information

Specify on the company information worksheet any information that technical service personnel (or your service provider) can use to contact you as quickly as possible or to access your storage complex.

This information includes the following items:

- General company information, such as company name and telephone number
- Administrator or support contact information. This information should be generic, in a business to business context, and not contain any personal information.
- Storage complex location

You must complete this worksheet for all installations that include a management console.

Management console network settings

Use the management console network setting worksheet to specify the IP address and LAN settings for your management console.

The management console network settings include the following items:

- Management console network identification
- Ethernet settings, if you want the management console to connect to your LAN
- DNS settings, if you plan to use a domain name server to resolve network names
- Routings, if you want to specify a default gateway for routing

Note: Your LAN is attached after the storage complex is installed and in operation.

You must complete the worksheet for all installations that include a management console. Before you complete the worksheet, review the exceptions that are listed in the notes at the bottom of the worksheet.

Remote support settings

The remote support worksheets specify whether you want outbound (call home) or inbound (remote services) remote support, or both.

Ensure that you enable both outbound and inbound support to help you maintain the highest availability of your data.

When you enable outbound (call home) remote support, your management console sends an electronic call home record to support when there is a problem within the storage complex. If inbound remote service is also enabled, a technical service representative can securely sign on to the management console from a remote location in response to the service call.

The storage system uses secure Internet SSL connectivity for the outbound (call home) remote support connection.

Assist On-Site (AOS) is available as a secure inbound remote service option. AOS provides a mechanism to establish a secure network connection to IBM over the internet by using SSL encryption. AOS can be installed on a customer gateway server in a DMZ or, if your security guidelines allow, it can run directly on the storage system.

In addition to AOS, you can also use 'rsc' (remote support center). It is a simple SSH proxy based remote service solution which can be used if AOS does not meet your security guidelines. Contact your technical service representative for more information on rsc.

Remote code load (RCL) requires outbound (call home) remote support, and either AOS or rsc.

The management console can also be configured to offload error logs to IBM over the Internet by using FTP. This option is normally only used when the customer does not want to send error logs over an encrypted connection.

For any of the remote support connectivity methods, you can use the data storage command-line interface (DS CLI) and its audit log feature to review who completed any remote service on your storage system, and at what time the work was completed. Contact your technical service representative for more information on which service actions are completed remotely. You can also use DS CLI to control network and remote service access to each management console and the storage system.

The IBM AOS Redbook at <http://www.redbooks.ibm.com/abstracts/redp4889.html?Open> provides additional information on AOS as a secure remote service solution.

When you configure a proxy server with AOS or Call Home configuration settings, you can install and use your own certificate if needed. For more information, see the IBM DRI System Connectivity and Security document at <https://www.ibm.com/support/pages/ibm-dri-system-connectivity-and-security-v335>.

You must complete the worksheet for all installations that include a management console.

Notification settings

Use the notification worksheets to specify the types of notifications that you want to receive and that you want others to receive.

Note: The technical service representative sets up the notification process.

Notifications contain information about your storage complex, such as serviceable events.

You can receive notifications through the following methods:

- Simple Network Management Protocol (SNMP) traps
- Email

You can choose one or both notification methods.

When you choose to have your storage complex generate SNMP traps, you can monitor the storage complex over your network. You can control whether management information base (MIB) information is

accessible and what type of SNMP traps to send. You can also specify the maximum number of traps that are sent for each event and where to send the traps.

Notes:

1. If you have open-systems hosts and remote mirror and copy functions, you must enable SNMP notifications for status reporting.
2. If you plan to use advanced functions SNMP messaging, you must set those functions by using DS CLI.

When you choose to enable email notifications, email messages are sent to all the email addresses that you specify on the worksheet when the storage complex encounters a serviceable event or must alert you to other information.

You must complete the worksheet for each management console to be installed.

Control switch settings

Use the control switch settings worksheet to specify certain settings that affect host connectivity. You are asked to enter these choices on the control switch settings worksheet so that your technical service representative can set them during the installation of your storage system.

The following control switches are set using the choices you specify on the control settings worksheet.

IBM i LUN serial suffix number

Use this control switch setting only when you attach more than one DS8000 storage system to an AS/400 or IBM i host *and* the last three digits of the worldwide node name (WWNN) are the same on any of the storage systems.

Control switch settings - attachment to IBM Z

The following control switch settings are specific to IBM Z .

Control-unit initiated reconfiguration (CUIR) support

Control-unit initiated reconfiguration (CUIR) allows automation of channel path quiesce and resume actions during certain service actions. This setting eliminates the requirement for manual actions from the host.

Control unit threshold

This control switch provides the threshold level, presenting a SIM to the operator console for controller related errors. SIMs are always sent to the attached IBM Z hosts for logging to the Error Recording Data Set (ERDS). SIMs can be selectively reported to the IBM Z host operator console, as determined by SIM type and SIM severity.

Device threshold

This control switch provides the threshold level, presenting a SIM to the operator console for device related errors. Device threshold levels are the same type and severity as control unit threshold settings.

Lights-on fast load for host adapters

Fibre Channel lights-on fast load provides seamless microcode update to storage arrays, and eliminates potential loss of access.

Media threshold

This control switch provides the threshold level, presenting a SIM to the operator console for media related errors. Media threshold levels are the same type and severity as control unit threshold settings.

Present SIM data to all hosts

Service Information Messages (SIMs) are offloaded to the first I/O request directed to each logical subsystem in the storage facility if the request is device or control unit related, or offloaded to the individual logical volume when the request is media related. This control switch determines whether SIMs are sent to all, or to only the first, attached IBM Z LPAR making an I/O request to the logical system or logical volume.

IBM Z high-performance FICON enhanced buffer management

IBM Z high-performance FICON enhanced buffer management provides improved performance for multi-site configurations when writing data remotely (remote site recovery).

Chapter 8. Planning data migration

The planning and methods of data migration for the storage system vary by environment.

When you plan for data migration, consider the following factors:

Note: The following lists do not cover every possibility. They provide a high-level view of some of the tools and factors that you can consider when you move data.

Data

- How much data is to be migrated?

Operating system

- Is it a IBM Z or UNIX system? Consider using Remote Mirror and Copy functions such as Metro Mirror, Global Mirror, or some variation of a logical volume manager.
- Is it z/OS? Consider using DFDSS, though there are many choices.
- Is it VM? Consider using DASD Dump Restore or PTAPE.
- Is it VSE? Consider using the VSE **fastcopy** or **ditto** commands.

Your system administrator selects the data migration method that is the best compromise between efficiency and impact on the users of the storage system.

Storage system

- Are the storage systems involved the same type with the same level of licensed machine code?
- Are the storage systems different? If the storage systems are different, ensure that the new configuration is large enough to accommodate the existing data. You also want to ensure that the virtual disks are similar in configuration to the disk drives that they are replacing.

Time and complexity

- What duration of service outage can be tolerated? Typically data migration requires that updates or changes cease while the movement occurs. Also, depending on the amount of data that you are moving and your migrating method, data might be unavailable for an extended time, even several hours.
- Does the complexity and time that is involved require the services of IBM through International Global Services? Contact your technical support representative for more information.

When you replace existing storage, partition the storage so that the virtual disks are similar in configuration to the disk drives that they are replacing. New configurations must be large enough to accommodate the existing data.

You might want to take advantage of this opportunity to do some remapping. The allocation and distribution of data are not required to be a straight one-to-one relationship, although that is possible. For instance, you can take advantage of using a maximum of 255 logical subsystems whereas the prior limitation was 32 logical subsystems.

Consider creating any new fixed block (FB) volumes with T10 DIF protection. This protection can be used on volumes to which data is migrated, even if the current host server volumes are not T10-protected. T10 DIF-protected volumes can be used even if the host server does not currently support T10 DIF.

Selecting a data migration method

The data migration method that you select must provide the best compromise between efficiency and impact on the system users. The selected method provides a simple but robust method that minimizes user impact.

Most methods of data migration affect the everyday operation of a computer system. When data is moved, the data must be in a certain state, and typically requires that updates or changes cease while the

movement occurs. Depending on the amount of data that you are moving and your migration method, data might be unavailable for an extended period, perhaps several hours. The following factors might contribute to the migration time:

- Creating new logical volumes or file systems
- Modifying configuration files
- Receiving integrity checks

Consider the following items to determine the best method for your data migration:

- Management software provides simple robust methods that you can use during production without disturbing users.
- The AIX logical volume manager (LVM) provides methods that you can use at any time without disrupting user access to the data. You might notice a small performance degradation, but this is preferable to shutting down databases or requiring users to log off the system.

Notes:

- AIX and HP-UX 11.xx ship with logical volume management (LVM) software as part of the base operating system. LVM provides complete control over all disks and file systems that exist on an AIX system. HP-UX has similar volume management software.
- Sun Microsystems has a basic volume management product that is called Solstice, which is available for the Solaris systems.
- Linux systems also use the LVM.
- Methods that use backup and restore procedures have the most impact on the system usage. These procedures require that databases and file systems are in quiescent states to ensure a valid snapshot of the data.

Table 58 on page 148 compares data migration options and lists advantages and disadvantages of each.

<i>Table 58. Comparison of data migration options</i>			
Type	Example	Advantages	Disadvantages
OS / LVM Mirroring	Logical Volume Managers, (LVM) Veritas Volume Manager (VxVM), Windows Disk Administrator	Little or no application service disruption	Potential application delays
UNIX or Windows Commands	cpio, cplv, dd, tar, backup restore; copy, scopy, xcopy, drag and drop	Common, easy to use, tested	Length of service interruption varies; scripting prone to errors and more testing
Remote Copy	Synchronous Mirror (Metro Mirror); Asynchronous Mirroring (Global Mirror and Global Copy)	Operating system independent	Like storage device types needed
Third-party software packages	Data Migration (XoSoft); Backup /Restore (Tivoli®, Legato, Veritas)	Some have little application service interruption, standard utilities	Cost of software; some have high application service interruption
Third-party migration appliances	IBM SAN Volume Controller, DataCore SANsymphony	Multiple heterogeneous storage vendors supported; migration cycles that are offloaded to appliance	Cost of migration appliance / service, application disruption to install / remove appliance

Chapter 9. Planning for security

The storage system provides functions to manage data secrecy and networking security, including data encryption, user account management, and functions that enable the storage system to conform with NIST SP 800-131A requirements.

Planning for data encryption

The storage system supports data encryption by using either a local key manager, or IBM Security Guardium Key Lifecycle Manager key servers.

Planning for encryption is a customer responsibility. There are three major planning components to the implementation of an encryption environment. Review all planning requirements and include them in the installation considerations.

Planning for remote encryption-key servers

One encryption-key server must be isolated. An isolated encryption-key server is a set of dedicated server resources that run only the encryption-key lifecycle manager application and its associated software stack. This server is attached directly to dedicated non-encrypting storage resources containing only key server code and data objects.

The remaining key servers can be of any supported key-server configuration. Any site that operates independently of other sites must have key servers for the encryption-enabled storage systems at that site.

For DS8000 encryption environments a second Hardware Management Console (HMC) should be configured for high availability.

Important: You are responsible for replicating key labels and their associated key material across all key servers that are attached to the encryption-enabled storage system before you configure those key labels on the system.

You can configure each encryption-enabled storage system with two independent key labels. This capability allows the use of two independent key-servers when one or both key-servers are using secure-key mode keystores. The isolated key-server can be used with a second key-server that is operating with a secure-key mode keystore.

To enable encryption on a storage system using TKLM or SKLM, you must upgrade to one of the following versions of TKLM or SKLM that has the Gen2 CA root installed:

- TKLM version 2.0.1 or later on Open Systems
- SKLM (all versions) on Open Systems
- SKLM version 1.1.0.2 or later on z/OS

DS8000 supports the following KMIP key servers:

- IBM Security Guardium Key Lifecycle Manager 3.0 or later (a multi-master or incremental replication configuration is required). IBM Fibre Channel Endpoint Security requires 3.0.1 fix-pack 2 or later.
- Gemalto Safenet KeySecure Classic 8.0.1, 8.3.2, 8.4.2, 8.5.0, 8.6.0, 8.7.0, 8.8.0, 8.9.0, 8.10.0, and 8.11.1
- Gemalto Safenet KeySecure Next Generation 1.7.0 and 1.8.0
- Thales CipherTrust Manager 2.0.0- 2.12.0 or later
- Vormetric DSM V6100 version 6.4.0.15031 or later
- Migration from Gemalto Safenet KeySecure 8.X to Thales CipherTrust Manager 2.X

Note: IBM Fibre Channel Endpoint Security does not support Gemalto Safenet KeySecure Classic, Gemalto Safenet KeySecure Next Generation, or Vormetric DSM. Security Guardium Key Lifecycle Manager must be configured with multi-master replication.

Note: DS8000 does not support communication with GKLM over IPP using custom device groups. KMIP is recommended for DS8000 systems communicating with IBM GKLM Key Servers in a Multi-Master configuration. When using IPP to communicate with IBM GKLM Key Servers in a Multi-Master configuration, it is not possible for the DS8000 systems to automatically detect problems related to key redundancy, leaving you responsible for determining when high availability disaster recovery (HADR) synchronization is not functioning properly. Loss of data in the GKLM key store can result in loss of DS8000 data.

Planning for key lifecycle managers

DS8000 storage systems support IBM Security Guardium Key Lifecycle Manager.

If NIST 800-131A security conformance is required on your storage system, select the version of IBM Security Guardium Key Lifecycle Manager that is appropriate for your encryption key server host and connection network protocol requirements.

- If your encryption key server runs on an open system host and you do not plan to use the Transport Layer Security (TLS) 1.2 or 1.3 protocol with this key server, use IBM Security Guardium Key Lifecycle Manager V2.6 or later.
- If your encryption key server runs on an open system host and you plan to use the TLS 1.2 or 1.3 protocol with this key server, use IBM Security Guardium Key Lifecycle Manager V2.6 or later.
- If your encryption key server runs on an IBM Z host LPAR with z/OS, use IBM Security Guardium Key Lifecycle Manager for z/OS V1.1.0.3 or later.
- If your encryption key server is Gemalto Safenet KeySecure, select version 8.0.0 or later.

If NIST 800-131A security conformance is not required on your storage system, select the appropriate encryption key manager for your encryption key server host.

- If your encryption key server runs on an open system host, install IBM Security Guardium Key Lifecycle Manager V2.6 or later.
- If your encryption key server runs on an IBM Z host LPAR with z/OS, install IBM Security Guardium Key Lifecycle Manager for z/OS v1.0.1 or later.

If you want to acquire a different isolated key server, refer to the *IBM Security Guardium Key Lifecycle Manager Installation and Configuration Guide* (SC27-5335) or IBM Security Guardium Key Lifecycle Manager online product documentation (www.ibm.com/docs/en/sgkml) for hardware and operating system requirements.

Note: You must acquire an IBM Security Guardium Key Lifecycle Manager license for use of the IBM Security Guardium Key Lifecycle Manager software that is ordered separately from the stand-alone server hardware. The IBM Security Guardium Key Lifecycle Manager license includes both an installation license for the IBM Security Guardium Key Lifecycle Manager management software and a license for encrypting drives.

IBM Security Guardium Key Lifecycle Manager for z/OS generates encryption keys and manages their transfer to and from devices in an IBM Z environment.

Planning for full-disk encryption activation

Full-disk-encryption drives are standard on the storage system. These drives encrypt and decrypt at interface speeds, with no impact on performance.

Full disk encryption offerings must be activated before use, as part of the system installation and configuration. This installation and activation review is performed by the IBM Systems Lab Services team. To submit a request or inquiry, see the [Storage Services website](http://www.ibm.com/storage) (www.ibm.com/storage), and click **Contact us**.

You are responsible for downloading or obtaining from IBM, and installing designated machine code (such as microcode, basic input/output system code [BIOS], utility programs, device drivers, and diagnostics that are delivered with an IBM system) and other software updates in a timely manner from the [ibm.com](http://www.ibm.com) website (www.ibm.com) or from other electronic media, and following the instructions that IBM provides. You can request IBM to install machine code changes; however, you might be charged for that service.

Planning for user accounts and passwords

Planning for administrative user and service accounts and passwords ensures that you use the best security practices.

Managing secure user accounts

Follow these recommended practices for managing secure user accounts.

Procedure

Complete the following steps to achieve the level of secure access for users that is required for your storage system.

1. Assign two or more storage administrators and two or more security administrators to manage your storage system. To preserve the dual control that is recommended for recovery key management, do not assign both storage administrator and security administrator roles to the same user. Change the password for both the default storage administrator and default security administrator user accounts, or delete the default user account after user accounts for other administrators are created.
2. Create one user account for each user who is authorized to access your storage system. Do not share a single user account between multiple users.
3. Assign appropriate user roles and scopes to user accounts in accordance with the storage management responsibilities of the user.
4. Review configurable user ID policies, and set the policies in accordance with your security objectives. The default settings are consistent with IBM recommended user ID and password policies and practices.
5. For applications that require network access to the storage system, assign a unique user ID (an ID that is not assigned to any other user). You can assign different user IDs for different software applications or different servers so that actions can be distinguished by user ID in the audit logs.
6. It is recommended to use remote authentication so that the user accounts are centralized and easily managed. For instance, you can revoke access to a user from multiple systems in a single step. You can use remote authentication that is provided by the following:
 - LDAP server.
 - Copy Services Manager (CSM) as a proxy for an LDAP server.
 - Multi-factor authentication (MFA) with RSA SecurID Authentication Manager.
 - Multi-factor authentication with Direct LDAP+RSA SecurID Authentication Manager.

In setting up an LDAP server, it is recommended to use the secure channel, Transport Layer Security (TLS), and enable a local administrator. There are three authentication methods that can be used when configuring LDAP: Simple, Anonymous, and Direct authentication. The recommended is direct authentication.

For configuring LDAP, the storage administrator requires the following information from an LDAP administrator:

- LDAP server name and port number.
- User and groups base for Distinguished Name (DN) lookup.
- A bind user DN and password if Simple authentication is used.
- Username attribute for logging in.

- Group name attribute and group membership attribute.

Managing secure service accounts

About this task

The DS Service GUI is a management console (HMC) interface for use by IBM Hardware Support. Access to the HMC is managed through the DS Service GUI. As an administrator you can manage users, user roles, and authentication methods. The recommended practice for account management is to create personal IDs to enable individual accountability. The DS Service GUI on the HMC also supports remote authentication and centralized user ID and password control through LDAP.

To add or manage users from the DS Service GUI, select **HMC Management** in the left hand pane. Then select **Manage User Profiles and Access**. When creating additional users only use the predefined roles of *esshmccustomer* or *esshmcserv* as listed in [Table 59 on page 152](#). Do not create users with the user role *esshmcppe*. This is reserved for IBM Support.

To configure remote authentication from the DS Service GUI, select **HMC Management** in the left hand pane. Then select **Configure LDAP**.

There are three predefined users for Customer, Service, and Engineering as shown in [Table 59 on page 152](#).

Table 59.

Predefined users	User role	Access requirement
customer	esshmccustomer	Requires a password for access regardless of authentication method.
CE	esshmcserv	Local access only. Requires an IBM Support Representative to be at the HMC.
PE	esshmcppe	Requires the IBM proprietary challenge/response key for remote access.

The roles, access, and properties for each user ID are described in [Table 60 on page 152](#).

Table 60.

Role	esshmccustomer	esshmcserv	esshmcppe
Access	Administration	Service (IBM SSR)	Service (IBM Remote Support)
Default user ID	customer	IBM use only	IBM use only
Default Password	cust0mer	IBM use only	IBM use only
Remove last user in this role	No	If the last user in this role is removed, the default user in this role will be created at the next HMC reboot.	If the last user in this role is removed, the default user in this role will be created at the next HMC reboot. This user should not be deleted. No users with this role should be made.

Table 60. (continued)			
Role	esshmccustomer	esshmcserv	esshmcpe
Backup and restore in the event of HMC rebuild	Yes	Yes	Yes
LDAP Authentication	Yes	Yes	Yes, additionally the default user with this role can log in only by using the IBM proprietary challenge/response process.

Note, the user IDs *root* and *hscroot* are not log in IDs, and cannot be accessed externally. Follow these recommended practices to manage access to your service account in the DS Service GUI and remote access by IBM Hardware Support.

Procedure

Complete the following steps to achieve the level of secure access that is required for service accounts on your storage system.

1. Assign one or more service administrators to manage service on your storage system.
2. Access the DS Service GUI from a web browser on a system that has network access to the Hardware Management Console (HMC) at `https://HMC_IP/service`, where *HMC_IP* is the IP address or host name of the HMC. You can also access the DS Service GUI from the link on the login page of the DS8000 Storage Management GUI.
3. Log in to the DS Service GUI by using the service administrator account. You will be required to change the password at the first login. The service administrator account is pre-configured with user ID (`customer`) and password (`cust0mer`). Create additional administrative users with the role *esshmccustomer* as needed for administration tasks.
4. Add or modify other users for IBM Hardware support as needed using the *esshmcserv* role. When creating new users with this role the default user property not allow remote access, requiring IBM Hardware support to be at the console locally. This can be changed for each user under **User Properties**.
5. Determine how you want IBM Remote Support to access your storage system and set remote service access controls accordingly. Before installation of the storage system, your IBM service representative consults with you about the types of remote service access available. Assist On-site (AOS) is the preferable method of secure remote service. AOS provides a mechanism to establish a secure network connection to IBM over the internet with SSL encryption. It can be configured so that the service administrator must approve remote service access and can monitor remote service activity.

Planning for NIST SP 800-131A security conformance

The National Institute of Standards and Technology (NIST) SP 800-131A is a United States standard that provides guidance for protecting data by using cryptographic algorithms that have key strengths of at least 112 bits.

Note: NIST-800-131a mode is enabled by default on the DS8900F HMC.

NIST SP 800-131A defines which cryptographic algorithms are valid and which cryptographic algorithm parameter values are required to achieve a specific security strength in a specific time period. Starting in 2014, a minimum-security strength of 112 bits is required when new data is processed or created.

In general, storage systems allow the use of 112-bit security strengths if the other unit that is attached to the network connection supports 112-bit security strength. If security levels are set to conform with NIST SP 800-131A guidelines, the storage system requires 112-bit security strength on TLS connections, other than remote support network connections.

On network connections that use TLS protocols, 112-bit security has the following requirements:

- The client and server must negotiate the use of either TLS 1.2 or TLS 1.3.
- The client and server must negotiate an approved cipher suite that uses cryptographic algorithms with at least 112-bit security strength.
- The client or server must limit hash and signature algorithms to provide at least 112-bit security strength; for example, the client must prevent the use of SHA-1 hashes.
- Certificates that are used by the client or server must have public keys and digital signatures with at least 112-bit security strength, such as RSA-2048 keys with SHA-256 digital signatures.
- Deterministic random bit generators (DRBGs) must use approved algorithms with a least 112-bit security strength and must be provided with entropy sources that have at least 112 bits of entropy.

To enable NIST SP 800-131A security conformance in your environment, update the following entities. It might not be feasible to update all these entities at the same time because of various dependencies. Therefore, you can upgrade them for NIST SP 800-131A security conformance independently of each other.

- Encryption key servers
- Remote authentication servers
- DS Network Interface clients
- DS Network Interface server
- DS8000 Storage Management GUI and DS Service GUI servers
- SMI-S agents



Attention: Before you disable earlier TLS protocols on the storage systems, you must ensure that all external system networks connected to the storage systems are enabled for TLS 1.2 and 1.3, and are NIST SP 800-131A compliant. Otherwise, network connection to these systems will be prohibited.

Remote authentication

Remote authentication allows users to authenticate to the system that uses credentials that are stored on an external authentication service. When you configure remote authentication, you do not need to configure users on the system or assign more passwords. Instead, you can use your existing passwords and user groups that are defined on the remote service to simplify user management and access to enforce password policies more efficiently, and to separate user management from storage management.

You can use remote authentication that is provided by the following:

- LDAP server.
- Copy Services Manager (CSM) as a proxy for an LDAP server.
- Multi-factor authentication (MFA) with RSA SecurID Authentication Manager.
- Multi-factor authentication with Direct LDAP+RSA SecurID Authentication Manager.

Remote authentication with LDAP

For configuring LDAP, the storage administrator requires the following information from an LDAP administrator:

- LDAP server name and port number.
- User and groups base for Distinguished Name (DN) lookup.
- A bind user DN and password if Simple authentication is used.
- Username attribute for logging in.
- Group name attribute and group membership attribute.

You can export and import a file that contains the configuration settings for a remote authentication policy that uses a direct LDAP connection.

The IBM LDAP Authentication for IBM DS8000 Systems Redbooks at <https://www.redbooks.ibm.com/abstracts/redp5460.html> provides additional information on remote authentication with LDAP.

Remote authentication with Copy Services Manager

For remote authentication, you can use the HMC embedded CSM instance or a CSM instance that is installed on an independent distributed server. The IBM Copy Services Manager Implementation Guide Redbooks at <https://www.redbooks.ibm.com/abstracts/sg248375.html> provides additional information on Copy Services Manager.

Remote authentication with multi-factor authentication- RSA SecurID Authentication Manager

In remote authentication with MFA, the verification of all authentication factors is delegated to the MFA server. The supported system is RSA SecurID Authentication Manager.

Remote authentication with multi-factor authentication- Direct LDAP+RSA SecurID Authentication Manager

In remote authentication with a direct connection to LDAP server and RSA SecurID Authentication Manager, the DS8000 is configured for the first factor authentication on an LDAP server and the second factor authentication on the MFA server.

To configure DS8000 storage system for remote authentication, see the topic titled *Using remote authentication* in the latest version of [DS8900 documentation](#).

Chapter 10. License activation and management

The management and activation of licensed functions are responsibilities that are associated with the role of your storage administrator.

Management refers to the use of the [IBM Entitled Systems Support \(ESS\) website](#) to select a license scope and to assign a license value. You can complete these activities and then activate the function.

Activation refers to the retrieval and installation of the feature activation code into the storage system. The feature activation code is obtained by using the [IBM Entitled Systems Support \(ESS\) website](#) and is based on the license scope and license value.

You complete these activities at the following times:

- After the technical service representative installs your storage system, and before you configure it.
- When you increase the extent of the function authorization for a licensed function (that is, you add more capacity to your license).

To complete these activities, access the [IBM Entitled Systems Support \(ESS\) website](#).

When you access the ESS website, you must enter information about your storage system so the web application can access the correct function authorization records. You can find this information either by clicking **Need Help** in the **Activate Licensed Functions** page or by selecting **Properties** on the **System** page of the DS8000 Storage Management GUI.

Planning your licensed functions

As you plan for your licensed functions, it is important to consider increases in your workload requirements. To provide more flexibility with licensing, use-based licensing is supported on the storage system.

The Base Function license is based on the entire capacity of the storage system.

The z-synergy Services and Transparent Cloud Tiering (TCT) licenses are priced based on the raw capacity of the arrays that you want to use with CKD volumes. On the other hand, the Copy Services licenses are priced based on the provisioned capacity of the storage system.

With the use-based license capability comes the requirement to plan how much storage capacity you require for future growth. As you plan for your licensed functions, it is important to consider increases in your workload requirements. For example, consider the following guidelines, which include but are not limited to:

- Plan for storage space allocation. Determine your typical storage requirements and consider how much more storage you would need if you have rapid or unpredictable growth.
- Estimate the amount of capacity you need for current and future Copy Services functions. For example, consider the number of target volumes you need for FlashCopy relationships at remote sites. As the number of FlashCopy target volumes increase, more available bandwidth of the disk system might be used by the copy process. In addition, Copy Services solutions that require multiple copies of data can also require extensive capacity storage.

Recognizing that both your storage and data requirements will increase over time and that capacity and performance planning is your responsibility, ensure that you purchase and manage your licensed functions for maximum usage. It can be more cost effective to purchase more storage capacity to ensure that the maximum usage of your licensed functions does not exceed the allowed capacity of the storage that was purchased. If the capacity is exceeded, IBM is notified that the usage exceeds the allowed capacity on any given licensed function. You are notified by IBM and required to extend enablement of your licensed function and install a new licensed feature key.

Activation of licensed functions

After the technical service representatives complete your DS8000 series installation, your first step is to activate your licensed functions.

To activate your licensed functions, complete the following actions.

- Obtain your feature activation codes.
- Apply the feature activation codes to your storage system. You can apply the feature activation codes by importing a downloadable file from the [IBM Entitled Systems Support \(ESS\) website](#).

The initial enablement of any optional DS8000 licensed function is a concurrent activity (assuming that the appropriate level of microcode is installed on the storage system for the function).

Note: Removal of a DS8000 licensed function to deactivate the function is non-disruptive, but takes effect at the next IML.

Activating licensed functions

You must obtain feature activation codes for the licensed features for each storage system by connecting to the [IBM Entitled Systems Support \(ESS\) website](#).

Before you begin

Before you can connect to the site, ensure that you have the following items:

- A removable media for downloading your feature activation codes into a file. Use the removable media if you cannot access the Storage Manager from the system that you are using to access the ESS website. Instead of using removable media, you can also write down the activation codes and then manually enter them into the system that runs the Storage Manager.
- The system serial number, model, and signature.

Notes:

1. Enabling an optional licensed function is a concurrent activity (assuming the appropriate level of microcode is installed for the function). The following activating activities are non-disruptive, but take effect at the next IML:
 - Removal of a licensed function for its deactivation.
 - A lateral change or reduction in the license scope. A lateral change is defined as changing the license scope from fixed block (FB) to count key data (CKD) or from CKD to FB. A reduction is defined as changing the license scope from all raw capacity (ALL) to only FB or only CKD capacity.
2. Before you begin this task, you must resolve any current system problems. Contact IBM Hardware Support for assistance.
3. Before you configure, disable or provide paths through any firewall because it might interfere with system communication.

About this task

Complete the following steps to activate feature activation codes.

Procedure

You can activate the licensed functions from one of two locations in the DS8000 Storage Management GUI: the **System Setup** wizard during initial configuration; or the **Licensed Functions** tab of the **System settings** page.

1. Click **Activate Licensed Functions** or **Activate**.
2. Enter the license keys.
 - If you received your license keys from a technical service representative, enter them in the **Activate Licensed Functions** window.

- If you need to obtain your license keys from the IBM Entitled Systems Support (ESS) website, complete the following steps.
 - a. Go to the [IBM Entitled Systems Support \(ESS\) website](#).
 - b. Click **Log in**.
 - c. Enter your IBMid.
 - d. Click **Continue**.
 - e. Enter your IBMid password.
 - f. Click **Log in**.
 - g. Click **My Entitled Hardware**.
 - h. Click **Storage License Management**.
 - i. Click **DS8000** tile.
 - j. Select the machine type from the menu. Enter the serial number and machine signature of your DS8000 system. You can find this information either by clicking **Need Help** in the **Activate Licensed Functions** window or by selecting the **Properties** action on the **System** page.
 - k. Click **Search**.
 - l. Click **Actions**.
 - m. Click **Download all authorization codes** to get the license keys XML file.
 - n. In the **Activate Licensed Functions** window, click the **Browse** icon to select the license keys XML file that you downloaded and click **Open**.
- 3. Click **Activate**.

Scenarios for managing licensing

These topics provide scenarios for managing your licenses after you initially activate them.

The following scenarios are provided:

- Adding storage capacity to an existing storage system
- Managing an active license feature

Note: More scenarios can be found on the IBM DS8000 Information Center.

Adding storage to your machine

You can add storage (in terabytes) to an existing licensed function, such as Copy Services.

About this task

For example, assume that you initially purchased 250 TB of Copy Services capacity. After several months, you need an extra 100 TB for your point-in-time copy operations. To increase storage, you must purchase and activate a larger license. This activity is nondisruptive and does not require that you restart your storage system.

Procedure

1. For example, you order four of the Copy Services feature code BAB3 (25 TB each for a total of 100 TB) against the serial number of the 5341 or 9031 machine type license currently on your storage system. This additional license capacity increases your Copy Services authorization level.
2. After you order the features, you receive confirmation from IBM that these new features were processed.
3. Connect to the [IBM Entitled Systems Support \(ESS\) website](#) to retrieve the feature activation code for the licensed feature.

This new feature activation code represents the total capacity that is now licensed (or 350 TB). It licenses the original 250 TB plus the additional 100 TB that you just ordered.

4. Obtain the feature activation code for the licensed feature from your sales representative.
5. After you obtain the feature activation code for the licensed feature, enter it into the DS8000 Storage Management GUI.
You replace the existing feature activation code with the new feature activation code.
6. After the feature activation code is installed successfully, you now have 350 TB of Copy Services capacity.

Managing a licensed feature

Use the IBM Entitled Systems Support (ESS) website to change an optional function from active to inactive. Change an assigned value, such as current number of terabytes, for a function to make that licensed function inactive.

About this task

If you have an active optional function and decide to replace it with an inactive function, the function is turned off. You can use the following steps if you want to use the feature again.

Procedure

1. From the [IBM Entitled Systems Support \(ESS\) website](#), change the assigned value from the current number of terabytes (TB) to 0 TB.
2. If this change is made, you can go back to the ESS website and reactivate the function, up to the previously purchased level, without having to repurchase the function.

Appendix A. Accessibility features

Accessibility features help users who have a disability, such as restricted mobility or limited vision, to use information technology products successfully.

Accessibility features

These are the major accessibility features associated with the IBM DS8000 series online product documentation.

- You can use screen-reader software and a digital speech synthesizer to hear what is displayed on the screen.
- This product uses standard Windows navigation keys.
- Interfaces that are commonly used by screen readers.
- Keys are discernible by touch but do not activate just by touching them.
- Industry-standard devices, ports, and connectors.
- The attachment of alternative input and output devices.

DS8000 online product documentation and its related publications are accessibility-enabled. The accessibility features of the online documentation are described in the [IBM Documentation website \(www.ibm.com/docs\)](http://www.ibm.com/docs).

Keyboard navigation

You can use keys or key combinations to perform operations and initiate menu actions that can also be done through mouse actions. You can navigate the online documentation from the keyboard by using the shortcut keys for your browser or screen-reader software. See your browser or screen-reader software Help for a list of shortcut keys that it supports.

Appendix B. Warranty information

The statement of limited warranty specifies the warranty period, type of warranty service, and service level.

See [IBM Warranty Information](#) for information on machine type models 5341.

Appendix C. IBM equipment and documents

Use the documents provided with your storage system to identify and check your main components.

The equipment that you receive can be grouped as follows:

- Components that must stay with the shipment because they are needed for installation
- Components that are for customer use
- Components that must stay with the storage system after installation because they are needed by your technical service representatives

Note: These lists are not intended to be a comprehensive list. They describe only the main shipped components.

Installation components

Your shipment includes all the equipment that is needed for the installation of your storage systems. Equipment includes storage systems, power cords, adapters, cables, installation instructions, and other essential material.

The following installation components are included with your shipment:

Model A01, A05, and E05 Storage system

Your shipment includes one or more of the following frames that you ordered:

- Base frame
- Expansion frames

When the frames arrive, they contain any ordered I/O enclosures, device adapters, storage enclosures, drives, and the appropriate cables to support those components. IBM Installs these components at the factory.

Hardware Management Console Model A01, A05

A primary and secondary management console are included with each base frame that you order. The management consoles are physically located (installed) inside the base frame.

Power cords

Your shipment includes the power cords that you ordered.

Various media

The product ships with the following media, which are used during the installation of your storage systems:

- Installation media, which includes installation scripts for the I/O attachment for AIX and HP-UX, DS CLI (command-line interface) software, and IBM Multipath Subsystem Device Driver installation instructions and software
- Licensed machine code (LMC) media for the MC
- Operating system media
- LMC media for the 5341 machine type
- Quick Code Reference document that details program code, utilities, and documentation included in the ship group

Hardcopy installation instructions

Your shipment includes hardcopy installation instructions for the technical service representatives who install your storage system.

Engineering changes (if applicable)

IBM occasionally releases engineering changes (ECs) to correct problems or provide more support. If released, these ECs are included in your shipment for the technical service representative to install.

Customer components

IBM provides media and documents that are intended for you to keep.

- License and warranty documents
- READ ME FIRST for IBM products
- Quick Code Reference, which includes a listing of customer publications and media that is provided with the storage system
- Customer publications' USB flash drives: One flash drive contains PDFs of customer publications and the other flash drive contains PDFs of license and warranty documents.

Service components

IBM provides service-related media and documents with your storage system.

Keep the following components with your storage system so that technical service representatives can use them when they service your storage system.

Service media

Your delivery includes the following media for technical service representatives to use:

- Operating system media
- Management console media:
 - Management console critical backup SDHC memory card
 - Dump, trace, statesave SDHC memory card, which technical support representatives use for extracting statesave information during service
- A program temporary fix (PTF) USB flash drive for the operating system
- Service documents USB flash drive, which includes the following documentation: DS8000 service documentation and the DS8000 parts catalog.

Appendix D. Configuration worksheets

You must complete the configuration worksheets before any installation of a new storage system or management console.

The configuration worksheets are frequently updated. To ensure that you use the latest version, download a spreadsheet file that contains all of the worksheets from IBM Support (<https://www.ibm.com/support/pages/node/6354259>).

Use the worksheets to specify the initial settings for your storage system. You can customize settings for company information, the management console network, remote support settings, notifications, power control, and control switch settings. For more details, refer to [Chapter 7, “Planning your storage complex setup,”](#) on page 143.

After you fill out the worksheets, give them to the technical service representatives who complete the installation.

Appendix E. Compliance standards

This product was designed, tested, manufactured, and certified for safe operation. It complies with IEC 60950-1 and/or IEC 62368-1 and where required, to relevant national differences/deviations (NDs) to these IEC base standards. This includes, but is not limited to: EN (European Norms including all Amendments under the Low Voltage Directive), UL/CSA (North America bi-national harmonized and marked per accredited NRTL agency listings), and other such derivative certifications according to corporate determinations and latest regional publication compliance standardized requirements.

Regulatory Model ID (RMID, for control system base platform): AP2 / IBM Storage DS8000 (10th Generation)

If no rack is included with this storage system, the MTM might be located within the hardware management console (HMC) interface, or on the head unit HMC chassis as a variable Print on Demand (PoD) label indicating its service identity.

Note: Relevant Machine Type - Models (MT-Ms) may also be used to supplement identification (ID) for worldwide (WW) co-compliance filings or registrations with regulatory bodies.

Appendix F. European Union General Data Protection Regulation Considerations

General Data Protection Regulation (GDPR) compliance is required by the European Union (EU), effective May 25, 2018.

GDPR establishes a stronger data protection regulatory framework for processing customer data. GDPR impacts IBM and IBM client contracts, policies, and procedures when handling personal data. GDPR features include:

- New and enhanced rights for individuals
- Widened definition of personal data
- New obligations for processors
- Potential for significant financial penalties for non-compliance
- Compulsory data breach notification

Read more about GDPR:

- <https://eugdpr.org>
- <https://www.ibm.com/data-responsibility/gdpr/>

Basic DS8A00 GDPR considerations

Complying with GDPR can present a challenge due to the variety of configurations and features available, and the number of ways products can be used separately and with third-party applications and systems. However, DS8A00 provides functions to help comply with GDPR, such as encryption of data at rest.

Your knowledge of Field Replaceable Units (FRUs) containing customer data is critical. The DS8A00 does not store or retain customer data in non-volatile memory other than data drives within the storage subsystem as written by your client applications. With encryption, if a drive fails and is replaced, the customer data is not readable from the replaced drive that is returned. Without encryption, you may need to retain and destroy failed drives to comply with GDPR. Your retention of the failed drive results in additional service costs due to the loss of failed parts credits.

Note: You are responsible for ensuring your compliance with various laws and regulations, including the EU GDPR. You are solely responsible for obtaining advice of competent legal counsel as to the identification and interpretation of any relevant laws and regulations that may affect your business and any actions you may need to take to comply with such laws and regulations.

The products, services, and other capabilities described herein are not suitable for all client situations, and may have restricted availability. IBM does not provide legal, accounting, or auditing advice or represent or warrant that its services or products ensure that clients are in compliance with any law or regulation.

Appendix G. Data privacy

IBM intends to protect your personal information and to maintain its integrity.

IBM implements reasonable physical, administrative, and technical safeguards to help protect your personal information from unauthorized access, use, and disclosure. For example, the products only provide IBM data about the asset usage and configuration, but do not reflect private use of the asset. When diagnostics are sent to IBM in the case of a problem submission, that data is routed directly to a secured infrastructure, and only individuals with a need to know are given access while working to resolve your problem. When appropriate, we also require that our suppliers protect such information from unauthorized access, use, and disclosure.

For more information, see the IBM Privacy Statement at <https://www.ibm.com/privacy/details/us/en>

Notices

This information was developed for products and services offered in the US. This material might be available from IBM in other languages. However, you may be required to own a copy of the product or product version in that language in order to access it.

IBM may not offer the products, services, or features discussed in this document in other countries. Consult your local IBM representative for information on the products and services currently available in your area. Any reference to an IBM product, program, or service is not intended to state or imply that only that IBM product, program, or service may be used. Any functionally equivalent product, program, or service that does not infringe any IBM intellectual property right may be used instead. However, it is the user's responsibility to evaluate and verify the operation of any non-IBM product, program, or service.

IBM may have patents or pending patent applications covering subject matter described in this document. The furnishing of this document does not grant you any license to these patents. You can send license inquiries, in writing, to:

*IBM Director of Licensing
IBM Corporation
North Castle Drive, MD-NC119
Armonk, NY 10504-1785
US*

For license inquiries regarding double-byte character set (DBCS) information, contact the IBM Intellectual Property Department in your country or send inquiries, in writing, to:

*Intellectual Property Licensing
Legal and Intellectual Property Law
IBM Japan Ltd.
19-21, Nihonbashi-Hakozakicho, Chuo-ku
Tokyo 103-8510, Japan*

INTERNATIONAL BUSINESS MACHINES CORPORATION PROVIDES THIS PUBLICATION "AS IS" WITHOUT WARRANTY OF ANY KIND, EITHER EXPRESS OR IMPLIED, INCLUDING, BUT NOT LIMITED TO, THE IMPLIED WARRANTIES OF NON-INFRINGEMENT, MERCHANTABILITY OR FITNESS FOR A PARTICULAR PURPOSE. Some jurisdictions do not allow disclaimer of express or implied warranties in certain transactions, therefore, this statement may not apply to you.

This information could include technical inaccuracies or typographical errors. Changes are periodically made to the information herein; these changes will be incorporated in new editions of the publication. IBM may make improvements and/or changes in the product(s) and/or the program(s) described in this publication at any time without notice.

Any references in this information to non-IBM websites are provided for convenience only and do not in any manner serve as an endorsement of those websites. The materials at those websites are not part of the materials for this IBM product and use of those websites is at your own risk.

IBM may use or distribute any of the information you provide in any way it believes appropriate without incurring any obligation to you.

The performance data discussed herein is presented as derived under specific operating conditions. Actual results may vary.

Information concerning non-IBM products was obtained from the suppliers of those products, their published announcements or other publicly available sources. IBM has not tested those products and cannot confirm the accuracy of performance, compatibility or any other claims related to non-IBM products. Questions on the capabilities of non-IBM products should be addressed to the suppliers of those products.

Statements regarding IBM's future direction or intent are subject to change or withdrawal without notice, and represent goals and objectives only.

This information is for planning purposes only. The information herein is subject to change before the products described become available.

This information contains examples of data and reports used in daily business operations. To illustrate them as completely as possible, the examples include the names of individuals, companies, brands, and products. All of these names are fictitious and any similarity to actual people or business enterprises is entirely coincidental.

Laser Notice: U.S. FDA CDRH NOTICE if low power lasers are utilized, integrated, or offered with end product systems as applicable. Complies with 21 CFR 1040.10 and 1040.11 except for conformance with IEC 60825-1 Ed. 3., as described in Laser Notice No. 56, dated May 8, 2019.

Trademarks

IBM, the IBM logo, and ibm.com[®] are trademarks or registered trademarks of International Business Machines Corp., registered in many jurisdictions worldwide. Other product and service names might be trademarks of IBM or other companies. A current list of IBM trademarks is available on the [Copyright and trademark information website](http://www.ibm.com/legal/copytrade.shtml) (www.ibm.com/legal/copytrade.shtml).

Adobe, the Adobe logo, PostScript, and the PostScript logo are either registered trademarks or trademarks of Adobe Systems Incorporated in the United States, and/or other countries.

Linux is a registered trademark of Linus Torvalds in the United States, other countries, or both.

Microsoft, Windows, and Windows NT are trademarks of Microsoft Corporation in the United States, other countries, or both.

Java and all Java-based trademarks and logos are trademarks or registered trademarks of Oracle and/or its affiliates.

UNIX is a registered trademark of The Open Group in the United States and other countries.

Homologation statement

This product may not be certified in your country for connection by any means whatsoever to interfaces of public telecommunications networks. Further certification may be required by law prior to making any such connection. Contact an IBM representative or reseller for any questions.

Safety and environmental notices

Review the safety notices, environmental notices, and electronic emission notices for this product before you install and use the product.

Safety notices and labels

Review the safety notices and safety information labels before using this product.

IBM Systems safety notices and information

The *IBM Systems Safety Notices* contains the safety notices for the IBM Systems products in English and other languages. It also contains the safety information labels found on the hardware in English and other languages. Anyone who plans, installs, operates, or services the system must be familiar with and understand the safety notices. Read the related safety notices before beginning work.

IBM Systems Safety Notices (http://public.dhe.ibm.com/systems/power/docs/hw/ENVSAF_SHR/G229-9054.pdf), G229-9054

The publication is organized into three sections:

Safety notices

Lists the danger and caution notices without labels, organized alphabetically by language.

The following notices and statements are used in IBM documents. They are listed in order of decreasing severity of potential hazards.

Danger notice definition

A special note that calls attention to a situation that is potentially lethal or extremely hazardous to people.

Caution notice definition

A special note that calls attention to a situation that is potentially hazardous to people because of some existing condition, or to a potentially dangerous situation that might develop because of some unsafe practice.

Labels

Lists the danger and caution notices that are accompanied with a label, organized by label reference number.

Text-based labels

Lists the safety information labels that might be attached to the hardware to warn of potential hazards, organized by label reference number.

Note: This product was designed, tested, manufactured, and certified for safe operation. It complies with IEC 60950-1 and/or IEC 62368-1 and where required, to relevant National Differences/deviations (NDs) to these IEC base standards. This includes, but is not limited to: EN (European Norms including all Amendments under the Low Voltage Directive), UL/CSA (North America bi-national harmonized and marked per accredited NRTL agency listings), and other such derivative certifications according to corporate determinations and latest regional publication compliance standardized requirements.

Finding translated notices

Each safety notice contains an identification number. You can use this identification number to check the safety notice in each language. The list of notices that apply to the product are listed in the [“Danger notices”](#) on page 183 and the [“Caution notices”](#) on page 177 topics.

To find the translated text for a caution or danger notice:

1. In the product documentation, look for the identification number at the end of each caution notice or each danger notice. In the following examples, the numbers (D002) and (C001) are the identification numbers.



DANGER: A danger notice indicates the presence of a hazard that has the potential of causing death or serious personal injury. (D002)



CAUTION: A caution notice indicates the presence of a hazard that has the potential of causing moderate or minor personal injury. (C001)

2. Open the [IBM Systems Safety Notices](#) (G229-9054) publication.
3. Under the language, find the matching identification number. Review the topics concerning the safety notices to ensure that you are in compliance.

To view a PDF file, you need Adobe Reader. You can download it at no charge from the [Adobe website](#) (get.adobe.com/reader/).

Caution notices

Ensure that you understand the caution notices.

Caution notices

Use the reference numbers in parentheses at the end of each notice, such as (C001), to find the matching translated notice in *IBM Systems Safety Notices*.



CAUTION: Energy hazard present. Shorting might result in system outage and possible physical injury. Remove all metallic jewelry before servicing. (C001)



CAUTION: Only trained service personnel may replace this battery. The battery contains lithium. To avoid possible explosion, do not burn or charge the battery.

Do Not:

- ___ Throw or immerse into water
- ___ Heat to more than 100 degrees C (212 degrees F)
- ___ Repair or disassemble

Exchange only with the IBM-approved part. Recycle or discard the battery as instructed by local regulations. In the United States, IBM has a process for the collection of this battery. For information, call 1-800-426-4333. Have the IBM part number for the battery unit available when you call. (C002)



CAUTION: Lead-acid batteries can present a risk of electrical burn from high, short-circuit current. Avoid battery contact with metal materials; remove watches, rings, or other metal objects, and use tools with insulated handles. To avoid possible explosion, do not burn.

Exchange only with the IBM-approved part. Recycle or discard the battery as instructed by local regulations. In the United States, IBM has a process for the collection of this battery. For information, call 1-800-426-4333. Have the IBM part number for the battery unit available when you call. (C004)



CAUTION: The battery is a lithium ion battery. To avoid possible explosion, do not burn. Exchange only with the IBM-approved part. Recycle or discard the battery as instructed by local regulations. In the United States, IBM has a process for the collection of this battery. For information, call 1-800-426-4333. Have the IBM part number for the battery unit available when you call. (C007)



CAUTION: This part or unit is heavy but has a weight smaller than 18 kg (39.7 lb). Use care when lifting, removing, or installing this part or unit. (C008)



CAUTION:

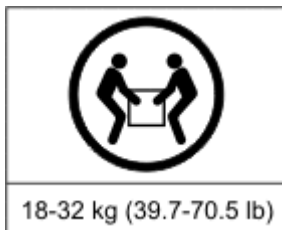

The weight of this part or unit is between 18 and 32 kg (39.7 and 70.5 lb). It takes two persons to safely lift this part or unit. (C009)



CAUTION: The doors and covers to the product are to be closed at all times except for service by trained service personnel. All covers must be replaced and doors locked at the conclusion of the service operation. (C013)



CAUTION: The system contains circuit cards, assemblies, or both that contain lead solder. To avoid the release of lead (Pb) into the environment, do not burn. Discard the circuit card as instructed by local regulations. (C014)



CAUTION: This product is equipped with a 3-wire (two conductors and ground) power cable and plug. Use this power cable with a properly grounded electrical outlet to avoid electrical shock. (C018)



CAUTION: The product might be equipped with a hard-wired power cable. Ensure that a licensed electrician performs the installation per the national electrical code. (C022)



CAUTION: Ensure the building power circuit breakers are turned off *BEFORE* you connect the power cord or cords to the building power. (C023)



CAUTION: To avoid personal injury, disconnect the hot-swap, air-moving device cables before removing the fan from the device. (C024)



CAUTION: This assembly contains mechanical moving parts. Use care when servicing this assembly. (C025)



CAUTION: This product might contain one or more of the following devices: CD-ROM drive, DVD-ROM drive, DVD-RAM drive, or laser module, which are Class 1 laser products. Note the following information:

- Do not remove the covers. Removing the covers of the laser product could result in exposure to hazardous laser radiation. There are no serviceable parts inside the device.
- Use of the controls or adjustments or performance of procedures other than those specified herein might result in hazardous radiation exposure.

(C026)



CAUTION: Data processing environments can contain equipment transmitting on system links with laser modules that operate at greater than Class 1 power levels. For this reason, never look into the end of an optical fiber cable or open receptacle. Although shining light into one end and looking into the other end of a disconnected optical fiber to verify the continuity of optic fibers may not injure the eye, this procedure is potentially dangerous. Therefore, verifying the continuity of optical fibers by shining light into one end and looking at the other end is not recommended. To verify continuity of a fiber optic cable, use an optical light source and power meter. (C027)



CAUTION: Servicing of this product or unit is to be performed by trained service personnel only. (C032)



CAUTION:

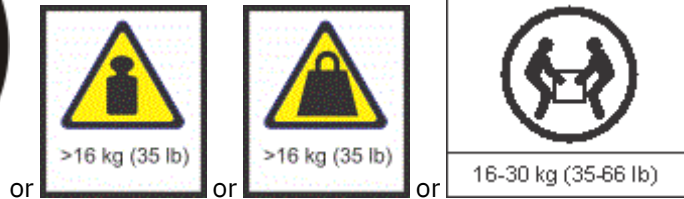

The weight of this part or unit is between 16 and 30 kg (35 and 66 lb). It takes two persons to safely lift this part or unit. (C040)



CAUTION: Refer to instruction manual. (C041)



CAUTION: Activate locks or brakes, or apply chocks as directed. Parts may shift or fall and cause personal injury or mechanical damage if these safeguards are not used. (C042)



CAUTION: Following the service procedure assures power is removed from 200-300 VDC and/or RMS Rectified AC power distribution connectors before they are unplugged. However, unplugging this power type range distribution connectors while powered on, should not be done because it can cause connector damage and could result in burn and/or shock injury from electrical arcing. (C043)



CAUTION: If your system has a module containing a lithium battery, replace it only with the same module type made by the same manufacturer. The battery contains lithium and can explode if not properly used, handled, or disposed of. Do not:

- Throw or immerse into water
- Heat to more than 100°C (212°F)
- Repair or disassemble Dispose of the battery as required by local ordinances or regulations.

(C045)



CAUTION: Depending on the rack configuration, it may be supplied with native built-in extendable outriggers with small floating supplemental casters as motion anti-tip features. They must all be extended into a latched position before and during cabinet movement or relocation. These native built-in outriggers must not be removed completely, but rather recessed in when finished to ensure they are readily available for future use. (C050)

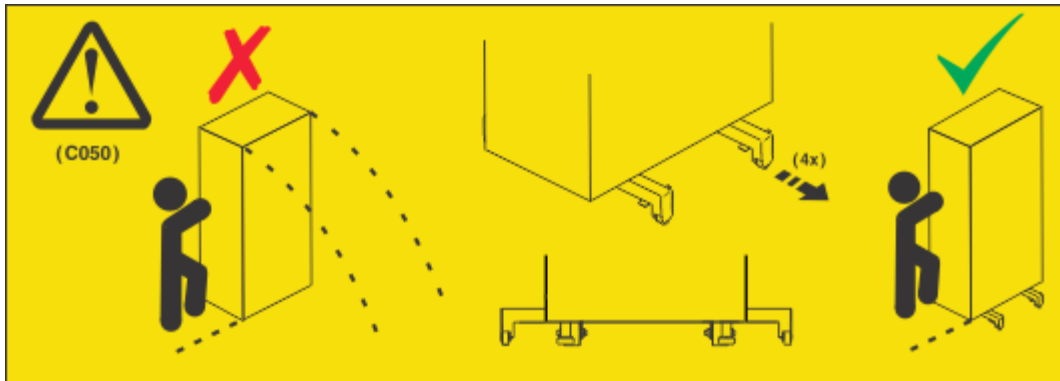

(R001 part 1 of 2):



DANGER: Observe the following precautions when working on or around your IT rack system:

- Heavy equipment—personal injury or equipment damage might result if mishandled.
- Always lower the leveling pads on the rack cabinet.
- Always install stabilizer brackets on the rack cabinet if provided, unless the earthquake option is to be installed.
- To avoid hazardous conditions due to uneven mechanical loading, always install the heaviest devices in the bottom of the rack cabinet. Always install servers and optional devices starting from the bottom of the rack cabinet.
- Rack-mounted devices are not to be used as shelves or work spaces. Do not place objects on top of rack-mounted devices. In addition, do not lean on rack mounted devices and do not use them to stabilize your body position (for example, when working from a ladder).



- Stability hazard:
 - The rack may tip over causing serious personal injury.
 - Before extending the rack to the installation position, read the installation instructions.
 - Do not put any load on the slide-rail mounted equipment mounted in the installation position.
 - Do not leave the slide-rail mounted equipment in the installation position.
- Each rack cabinet might have more than one power cord.
 - For AC powered racks, be sure to disconnect all power cords in the rack cabinet when directed to disconnect power during servicing.

- For racks with a DC power distribution panel (PDP), turn off the circuit breaker that controls the power to the system unit(s), or disconnect the customer’s DC power source, when directed to disconnect power during servicing.
- Connect all devices installed in a rack cabinet to power devices installed in the same rack cabinet. Do not plug a power cord from a device installed in one rack cabinet into a power device installed in a different rack cabinet.
- An electrical outlet that is not correctly wired could place hazardous voltage on the metal parts of the system or the devices that attach to the system. It is the responsibility of the customer to ensure that the outlet is correctly wired and grounded to prevent an electrical shock. (R001 part 1 of 2)

(R001 part 2 of 2):



CAUTION:

- Do not install a unit in a rack where the internal rack ambient temperatures will exceed the manufacturer's recommended ambient temperature for all your rack-mounted devices.
- Do not install a unit in a rack where the air flow is compromised. Ensure that air flow is not blocked or reduced on any side, front, or back of a unit used for air flow through the unit.
- Consideration should be given to the connection of the equipment to the supply circuit so that overloading of the circuits does not compromise the supply wiring or overcurrent protection. To provide the correct power connection to a rack, refer to the rating labels located on the equipment in the rack to determine the total power requirement of the supply circuit.
- *(For sliding drawers.)* Do not pull out or install any drawer or feature if the rack stabilizer brackets are not attached to the rack or if the rack is not bolted to the floor. Do not pull out more than one drawer at a time. The rack might become unstable if you pull out more than one drawer at a time.



- *(For fixed drawers.)* This drawer is a fixed drawer and must not be moved for servicing unless specified by the manufacturer. Attempting to move the drawer partially or completely out of the rack might cause the rack to become unstable or cause the drawer to fall out of the rack. (R001 part 2 of 2)



CAUTION: Removing components from the upper positions in the rack cabinet improves rack stability during relocation. Follow these general guidelines whenever you relocate a populated rack cabinet within a room or building.

- Reduce the weight of the rack cabinet by removing equipment starting at the top of the rack cabinet. When possible, restore the rack cabinet to the configuration of the rack cabinet as you received it. If this configuration is not known, you must observe the following precautions:
 - Remove all devices in the 32U position and above.
 - Ensure that the heaviest devices are installed in the bottom of the rack cabinet.

- Ensure that there are little-to-no empty U-levels between devices installed in the rack cabinet below the 32U level, unless the received configuration specifically allowed it.
- If the rack cabinet you are relocating is part of a suite of rack cabinets, detach the rack cabinet from the suite.
- If the rack cabinet you are relocating was supplied with removable outriggers they must be reinstalled before the cabinet is relocated.
- Inspect the route that you plan to take to eliminate potential hazards.
- Verify that the route that you choose can support the weight of the loaded rack cabinet. Refer to the documentation that comes with your rack cabinet for the weight of a loaded rack cabinet.
- Verify that all door openings are at least 760 x 2083 mm (30 x 82 in.).
- Ensure that all devices, shelves, drawers, doors, and cables are secure.
- Ensure that the four leveling pads are raised to their highest position.
- Ensure that there is no stabilizer bracket installed on the rack cabinet during movement.
- Do not use a ramp inclined at more than 10 degrees.
- When the rack cabinet is in the new location, complete the following steps:
 - Lower the four leveling pads.
 - Install stabilizer brackets on the rack cabinet or in an earthquake environment bolt the rack to the floor.
 - If you removed any devices from the rack cabinet, repopulate the rack cabinet from the lowest position to the highest position.
- If a long-distance relocation is required, restore the rack cabinet to the configuration of the rack cabinet as you received it. Pack the rack cabinet in the original packaging material, or equivalent. Also lower the leveling pads to raise the casters off of the pallet and bolt the rack cabinet to the pallet.

(R002)



DANGER: DANGER: Racks with a total weight of > 227 kg (500 lb.), Use Only Professional Movers! (R003)



DANGER: Do not transport the rack via fork truck unless it is properly packaged, secured on top of the supplied pallet. (R004)



CAUTION:

- Rack is not intended to serve as an enclosure and does not provide any degrees of protection required of enclosures.
- It is intended that equipment installed within this rack will have its own enclosure.

(R005)



CAUTION: Use safe practices when lifting. (R007)



CAUTION: Do not place any object on top of a rack-mounted device unless that rack-mounted device is intended for use as a shelf. (R008)



DANGER:



Main Protective Earth (Ground): This symbol is marked on the frame of the rack. The PROTECTIVE EARTHING CONDUCTORS should be terminated at that point. A recognized or certified closed loop connector (ring terminal) should be used and secured to the frame with a lock washer using a bolt or stud. The connector should be properly sized to be suitable for the bolt or stud, the locking washer, the rating for the conducting wire used, and the considered rating of the breaker. The intent is to ensure the frame is electrically bonded to the PROTECTIVE EARTHING CONDUCTORS. The hole that the bolt or stud goes into where the terminal connector and the lock washer contact

should be free of any non-conductive material to allow for metal to metal contact. All PROTECTIVE BONDING CONDUCTORS should terminate at this main protective earthing terminal or at points marked with  (R010)

Danger notices

Ensure that you understand the danger notices.

Danger notices

Use the reference numbers in parentheses at the end of each notice, such as (D001), to find the matching translated notice in *IBM Systems Safety Notices*.



DANGER: To prevent a possible shock from touching two surfaces with different protective ground (earth), use one hand, when possible, to connect or disconnect signal cables. (D001)



DANGER: Overloading a branch circuit is potentially a fire hazard and a shock hazard under certain conditions. To avoid these hazards, ensure that your system electrical requirements do not exceed branch circuit protection requirements. Refer to the information that is provided with your device or the power rating label for electrical specifications. (D002)



DANGER: An electrical outlet that is not correctly wired could place hazardous voltage on the metal parts of the system or the devices that attach to the system. It is the responsibility of the customer to ensure that the outlet is correctly wired and grounded to prevent an electrical shock. (D004)



DANGER: When working on or around the system, observe the following precautions:

Electrical voltage and current from power, telephone, and communication cables are hazardous. To avoid a shock hazard: If IBM supplied the power cord(s), connect power to this unit only with the IBM provided power cord. Do not use the IBM provided power cord for any other product. Do not open or service any power supply assembly. Do not connect or disconnect any cables or perform installation, maintenance, or reconfiguration of this product during an electrical storm.



- The product might be equipped with multiple power cords. To remove all hazardous voltages, disconnect all power cords. For AC power, disconnect all power cords from their AC power source. For racks with a DC power distribution panel (PDP), disconnect the customer's DC power source to the PDP.
- When connecting power to the product ensure all power cables are properly connected. For racks with AC power, connect all power cords to a properly wired and grounded electrical outlet. Ensure that the outlet supplies proper voltage and phase rotation according to the system rating plate. For racks with a DC power distribution panel (PDP), connect the customer's DC power source to the PDP. Ensure that the proper polarity is used when attaching the DC power and DC power return wiring.
- Connect any equipment that will be attached to this product to properly wired outlets.
- When possible, use one hand only to connect or disconnect signal cables.
- Never turn on any equipment when there is evidence of fire, water, or structural damage.
- Do not attempt to switch on power to the machine until all possible unsafe conditions are corrected.
- When performing a machine inspection: Assume that an electrical safety hazard is present. Perform all continuity, grounding, and power checks specified during the subsystem installation procedures to ensure that the machine meets safety requirements. Do not attempt to switch power to the machine until all possible unsafe conditions are corrected. Before you open the device covers, unless instructed otherwise in the installation and configuration procedures: Disconnect the attached AC power cords, turn off the applicable circuit breakers located in the rack power distribution panel (PDP), and disconnect any telecommunications systems, networks, and modems.
- Connect and disconnect cables as described in the following procedures when installing, moving, or opening covers on this product or attached devices.

To Disconnect: 1) Turn off everything (unless instructed otherwise). 2) For AC power, remove the power cords from the outlets. 3) For racks with a DC power distribution panel (PDP), turn off the circuit breakers located in the PDP and remove the power from the Customer's DC power source. 4) Remove the signal cables from the connectors. 5) Remove all cables from the devices.

To Connect: 1) Turn off everything (unless instructed otherwise). 2) Attach all cables to the devices. 3) Attach the signal cables to the connectors. 4) For AC power, attach the power cords to the outlets. 5) For racks with a DC power distribution panel (PDP), restore the power from the Customer's DC power source and turn on the circuit breakers located in the PDP. 6) Turn on the devices.



- Sharp edges, corners and joints may be present in and around the system. Use care when handling equipment to avoid cuts, scrapes and pinching. (D005)



DANGER: Heavy equipment—personal injury or equipment damage might result if mishandled. (D006)



DANGER: Uninterruptible power supply (UPS) units contain specific hazardous materials. Observe the following precautions if your product contains a UPS:

- The UPS contains lethal voltages. All repairs and service must be performed only by an authorized service support representative. There are no user serviceable parts inside the UPS.
- The UPS contains its own energy source (batteries). The output receptacles might carry live voltage even when the UPS is not connected to an AC supply.
- Do not remove or unplug the input cord when the UPS is turned on. This removes the safety ground from the UPS and the equipment connected to the UPS.
- The UPS is heavy because of the electronics and batteries that are required. To avoid injury, observe the following precautions:
 - Do not attempt to lift the UPS by yourself. Ask another service representative for assistance.
 - Remove the battery, electronics assembly, or both from the UPS before removing the UPS from the shipping carton or installing or removing the UPS in the rack.

(D007)



DANGER: Professional movers are to be used for all relocation activities. Serious injury or death may occur if systems are handled and moved incorrectly. (D008)

Labels

Labels

Use the reference numbers in parentheses at the end of each notice, such as (L001), to find the matching translated notice in *IBM Systems Safety Notices*.

(L001)



DANGER: Hazardous voltage, current, or energy levels are present inside any component that has this label attached. Do not open any cover or barrier that contains this label. (L001)

(L003)

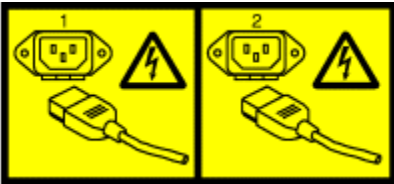

or



or





or



or

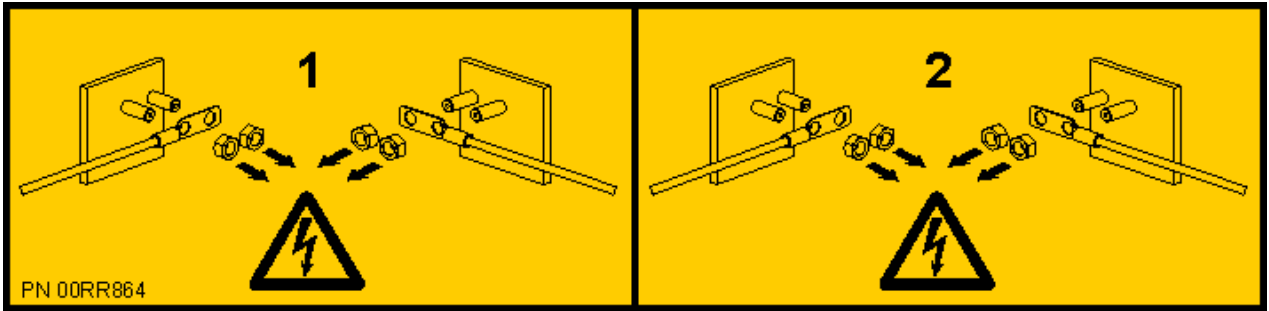



 **DANGER:** Multiple power cords. The product might be equipped with multiple AC power cords or multiple DC power cables. To remove all hazardous voltages, disconnect all power cords and power cables. (L003)

(L009)



 **CAUTION:** System or part is heavy. The label is accompanied by a specific weight range. (L009)

(L012)



or



 **CAUTION:** Pinch hazard. (L012)

(L025)



 **Attention:** Refer to the Installation Planning Guide for additional explanation on configurations supported for given voltage groups and Power Cord information. (L025)

(L026)





Attention: For use at altitude 2000 m or lower. (L026)

Text based labels

Text Based Labels



and / or



Vendor-specific uninterruptible power supply safety statements

These statements apply specifically to the vendor uninterruptible power supply (UPS).

General caution statements

- Do not use extension cords to connect to an AC outlet.
- Do not plug the UPS's input cord into its own output receptacles.
- Before using the UPS, you must unpack the UPS and allow it to adjust to room temperature (20-25degC) for at least two hours to avoid moisture condensing inside the UPS.
- Do not connect any equipment that may overload the UPS.
- Contact qualified service personnel if either of the following events occur:
 - Liquid is poured or splashed on the UPS.
 - The UPS does not run normally after its user manual has been carefully observed.
- The allowable storage temperature and relative humidity (non-condensing) are -15..+50 C and 5..95%RH.

Vendor-specific warning, caution, and danger statements

Warning: To reduce the risk of fire or electric shock, install in a temperature and humidity-controlled indoor area, free of conductive contaminants. Refer servicing to qualified service personnel only. Intended for installation in a controlled environment.



CAUTION:

- Risk of electrical shock. Capacitor stores hazardous energy. Do not remove cover for 5 minutes after disconnecting all sources of supply.
- Risk of electric shock. Hazardous live parts inside this unit are energized from the battery supply even when the input AC power is disconnected.
- Risk of electric shock. Do not remove cover. No user serviceable parts inside. Refer servicing to qualified service personnel.
- Risk of electric shock. This UPS receives power from more than one source. Disconnection of the AC sources and the DC sources is required to de-energize this unit before servicing.

Warning: Turn OFF the UPS and also cut off the AC input source before performing battery pack replacement.



CAUTION:

Risk of electrical shock. This battery cabinet receives power from more than one source.
The lead acid battery may cause chemical hazard.
This battery presents a risk of electric shock and energy hazard.
Lead (Pb) acid battery in the inside of the enclosure.
For disposal instructions for the battery, see user's manual.
Only open the battery compartment in the described way, do not disassemble other parts of the UPS.



DANGER: Risk of electric shock. Do not touch uninsulated battery terminal.



CAUTION:

Safety instructions - save these instructions! This manual contains important instructions that should be followed during installation and maintenance of the UPS and batteries.

This UPS contains batteries, which are potentially hazardous to user, even when the UPS is not connected to the utility power.

The AC output of the UPS need a disconnect switch such as a breaker which has to be provided by users.

The over-current protection for the output AC circuit has to be provided by users. The UPS has an electronic protection of AC output short circuit.

Servicing of batteries should be performed or supervised by personnel who are knowledgeable about batteries and the required precautions. Keep unauthorized personnel away from batteries.

When replacing batteries, replace with the same number and type of battery.

CAUTION! Do not dispose of battery or batteries in a fire. The batteries may explode.

CAUTION! Do not open or mutilate the battery or batteries. The released electrolyte is harmful to the skin and eyes. It may be toxic.

CAUTION! A battery can present a risk of electrical shock and high short circuit current. The following precautions should be observed when working on batteries.

- Remove watches, rings, or other metal objects.
- Use tools with insulated handles.
- Wear rubber gloves and boots.
- Do not lay tools or metal parts on the top of batteries.
- Disconnect charging source prior to connecting or disconnecting battery terminals.
- Determine if the battery is inadvertently grounded. If inadvertently grounded, remove source of ground. Contact with any part of a grounded battery can result in electrical shock. The likelihood of such shock will be reduced if such grounds are moved during installation and maintenance (applicable to UPS and a remote battery supply not having a grounded supply circuit).

Environmental notices

This information contains all the required environmental notices for IBM Systems products in English and other languages.

The *IBM Systems Environmental Notices* (<https://www.ibm.com/docs/environmental-safety?topic=environmental-safety-notice>) information includes statements on limitations, product information, product recycling and disposal, battery information, flat panel display, refrigeration and water-cooling systems, external power supplies, and safety data sheets.

Electromagnetic compatibility notices

The following Class A statements apply to IBM products and their features unless designated as electromagnetic compatibility (EMC) Class B in the feature information.

When attaching a monitor to the equipment, you must use the designated monitor cable and any interference suppression devices that are supplied with the monitor.

Canada Notice

CAN ICES-3 (A)/NMB-3(A)

European Community and Morocco Notice

This product is in conformity with the protection requirements of Directive 2014/30/EU of the European Parliament and of the Council on the harmonization of the laws of the Member States relating to electromagnetic compatibility. IBM cannot accept responsibility for any failure to satisfy the protection requirements resulting from a non-recommended modification of the product, including the fitting of non-IBM option cards.

This product may cause interference if used in residential areas. Such use must be avoided unless the user takes special measures to reduce electromagnetic emissions to prevent interference to the reception of radio and television broadcasts.

Warning: This equipment is compliant with Class A of CISPR 32. In a residential environment this equipment may cause radio interference.

Germany Notice

Deutschsprachiger EU Hinweis: Hinweis für Geräte der Klasse A EU-Richtlinie zur Elektromagnetischen Verträglichkeit

Dieses Produkt entspricht den Schutzanforderungen der EU-Richtlinie 2014/30/EU zur Angleichung der Rechtsvorschriften über die elektromagnetische Verträglichkeit in den EU-Mitgliedsstaaten und hält die Grenzwerte der EN 55032 Klasse A ein.

Um dieses sicherzustellen, sind die Geräte wie in den Handbüchern beschrieben zu installieren und zu betreiben. Des Weiteren dürfen auch nur von der IBM empfohlene Kabel angeschlossen werden. IBM übernimmt keine Verantwortung für die Einhaltung der Schutzanforderungen, wenn das Produkt ohne Zustimmung von IBM verändert bzw. wenn Erweiterungskomponenten von Fremdherstellern ohne Empfehlung von IBM gesteckt/eingebaut werden.

EN 55032 Klasse A Geräte müssen mit folgendem Warnhinweis versehen werden:

"Warnung: Dieses ist eine Einrichtung der Klasse A. Diese Einrichtung kann im Wohnbereich Funkstörungen verursachen; in diesem Fall kann vom Betreiber verlangt werden, angemessene Maßnahmen zu ergreifen und dafür aufzukommen."

Deutschland: Einhaltung des Gesetzes über die elektromagnetische Verträglichkeit von Geräten

Dieses Produkt entspricht dem "Gesetz über die elektromagnetische Verträglichkeit von Geräten (EMVG)." Dies ist die Umsetzung der EU-Richtlinie 2014/30/EU in der Bundesrepublik Deutschland.

Zulassungsbescheinigung laut dem Deutschen Gesetz über die elektromagnetische Verträglichkeit von Geräten (EMVG) (bzw. der EMC Richtlinie 2014/30/EU) für Geräte der Klasse A

Dieses Gerät ist berechtigt, in Übereinstimmung mit dem Deutschen EMVG das EG-Konformitätszeichen - CE - zu führen.

Verantwortlich für die Einhaltung der EMV-Vorschriften ist der Hersteller:

International Business Machines Corp.
New Orchard Road
Armonk, New York 10504
Tel: 914-499-1900

Der verantwortliche Ansprechpartner des Herstellers in der EU ist:

IBM Deutschland GmbH
Technical Relations Europe, Abteilung M456
IBM-Allee 1, 71139 Ehningen, Germany
Tel: +49 800 225 5426
e-mail: Halloibm@de.ibm.com

Generelle Informationen:

Das Gerät erfüllt die Schutzanforderungen nach EN 55024 und EN 55032 Klasse A.

Japan Electronics and Information Technology Industries Association (JEITA) Notice

(一社) 電子情報技術産業協会 高調波電流抑制対策実施
要領に基づく定格入力電力値 : IBM Documentationの各製品
の仕様ページ参照

This statement applies to products less than or equal to 20 A per phase.

高調波電流規格 JIS C 61000-3-2 適合品

This statement applies to products greater than 20 A, single phase.

高調波電流規格 JIS C 61000-3-2 準用品

本装置は、「高圧又は特別高圧で受電する需要家の高調波抑制対策ガイドライン」対象機器（高調波発生機器）です。

- 回路分類 : 6 (単相、PFC回路付)
- 換算係数 : 0

This statement applies to products greater than 20 A per phase, three-phase.

高調波電流規格 JIS C 61000-3-2 準用品

本装置は、「高圧又は特別高圧で受電する需要家の高調波抑制対策ガイドライン」対象機器（高調波発生機器）です。

- 回路分類 : 5 (3相、PFC回路付)
- 換算係数 : 0

Japan Voluntary Control Council for Interference (VCCI) Notice

この装置は、クラスA機器です。この装置を住宅環境で使用すると電波妨害を引き起こすことがあります。この場合には使用者が適切な対策を講ずるよう要求されることがあります。

VCCI — A

Korea Notice

이 기기는 업무용 환경에서 사용할 목적으로 적합성평가를 받은 기기로서 가정용 환경에서 사용하는 경우 전파간섭의 우려가 있습니다.

People's Republic of China Notice

警告:在居住环境中,运行此设备可能会造成无线电干扰。

Russia Notice

ВНИМАНИЕ! Настоящее изделие относится к классу А.
В жилых помещениях оно может создавать радиопомехи, для снижения которых необходимы дополнительные меры

RU200811

Taiwan Notice

CNS 13438

警告使用者：
此為甲類資訊技術設備，
於居住環境中使用時，可
能會造成射頻擾動，在此
種情況下，使用者會被要
求採取某些適當的對策。

CNS 15936

警告：為避免電磁干擾，本產品不應安裝或使用於住宅環境。

IBM Taiwan Contact Information:

台灣IBM 產品服務聯絡方式：
台灣國際商業機器股份有限公司
台北市松仁路7號3樓
電話：0800-016-888

f2c00790

United Kingdom Notice

This product may cause interference if used in residential areas. Such use must be avoided unless the user takes special measures to reduce electromagnetic emissions to prevent interference to the reception of radio and television broadcasts.

United States Federal Communications Commission (FCC) Notice

This equipment has been tested and found to comply with the limits for a Class A digital device, pursuant to Part 15 of the FCC Rules. These limits are designed to provide reasonable protection against harmful interference when the equipment is operated in a commercial environment. This equipment generates, uses, and can radiate radio frequency energy and, if not installed and used in accordance with the instruction manual, may cause harmful interference to radio communications. Operation of this equipment in a residential area is likely to cause harmful interference, in which case the user will be required to correct the interference at his own expense.

Properly shielded and grounded cables and connectors must be used in order to meet FCC emission limits. IBM is not responsible for any radio or television interference caused by using other than recommended cables and connectors, or by unauthorized changes or modifications to this equipment. Unauthorized changes or modifications could void the user's authority to operate the equipment.

This device complies with Part 15 of the FCC Rules. Operation is subject to the following two conditions:

(1) this device might not cause harmful interference, and (2) this device must accept any interference received, including interference that might cause undesired operation.

Responsible Party:

International Business Machines Corporation

New Orchard Road

Armonk, NY 10504

Contact for FCC compliance information only: fccinfo@us.ibm.com

Index

Numerics

2.5-inch [51](#)
4-port HA [52](#)
8-port HA [52](#)

A

accessibility
 features [161](#)
acclimation [107](#)
Activating licensed functions [158](#)
activating licenses [158](#)
adapters
 Fibre Channel host [87](#), [88](#)
 zHyperLink [90](#)
air circulation
 intake and exhaust [134](#)
air quality [136](#)
algorithms [57](#)
allocation methods [15](#)
AS/400 LUN
 control switch settings [145](#)
Attachment to IBM Z [145](#)
auto-rebalance [65](#)
auxiliary volumes [65](#)
availability features [51](#)

B

balancing the I/O load [54](#)
Base function license
 Easy Tier [100](#)
 Encryption Authorization [100](#)
 Operating environment license [101](#)
Base Function license
 thin provisioning [101](#)
bottom exit
 cable management [111](#)
 measurements [111](#)
 placement [111](#)
BSMI certificate [95](#)
BTU [132](#)

C

cable
 cutout locations [114](#)
 feature codes, Fibre Channel cable [88](#)
 feature codes, zHyperLink cable [90](#)
 Fibre Channel host adapter [87](#)
 I/O adapters [86](#)
 I/O cables [86](#)
 installation [114](#)
 overhead cable [114](#)
 RIO-G [86](#)

cable (*continued*)
 top exit bracket [114](#)
 zHyperLink adapter [90](#)
cables
 drive [83](#)
cache [92](#)
capacity
 calculating raw and usable [84](#)
 exhaust [132](#)
 floor load rating [117](#)
caution notices [176](#), [177](#)
CCW, channel command words [55](#)
certificate, BSMI [95](#)
circuit breakers
 high-voltage [131](#)
 low-voltage [131](#)
CKD, count key data storage [55](#)
clearances required for service [120](#)
CLI, command-line interface [16](#)
cloud
 transparent cloud tiering [61](#)
clusters, RAID disk groups [54](#)
CoD [51](#)
code
 loading [9](#)
 updating [9](#)
cold weather procedures [107](#)
comments, sending [ix](#)
communication requirements, host attachment [141](#)
company information [143](#)
concurrent code load [9](#)
configuration
 I/O (RIO-G) cables [86](#)
 processor memory [92](#)
configuration control indicators [81](#)
configuration overview [10](#)
Configuration overview [11](#)
configuration rules
 Standby CoD disk drives [83](#)
 storage devices [83](#)
 storage enclosures [83](#)
configuration worksheets [167](#)
connectivity
 I/O enclosures
 [86](#)
consolidating storage [55](#)
containers, shipping [108](#)
contamination information [137](#)
control switch settings [145](#)
control unit threshold [145](#)
conventions
 terminology [vii](#)
 typefaces [vii](#)
cooling [134](#), [138](#)
Copy Services
 considerations [69](#)
 disaster recovery [76](#)

- Copy Services (*continued*)
 - licensed functions [79](#)
 - overview [69](#)
 - Safeguarded copy function [105](#)
- Copy Services license
 - FlashCopy function [105](#)
 - Remote mirror and copy [105](#)
- Copy Services Manager [17](#)
- Copy Services software package
 - Remote mirror and copy [105](#)
- corrosive gasses and particulates [136](#)
- count key data storage [55](#)
- CUIR, control-unit initiated reconfiguration [145](#)
- customization worksheets [167](#)

D

- danger notices [176](#), [183](#)
- data
 - securing [79](#)
- data migration
 - selecting method [147](#)
- data placement [54](#)
- data privacy [173](#)
- description
 - VMware [67](#)
- description of Easy Tier [65](#)
- description of EAV [58](#)
- Device threshold [145](#)
- dimensions
 - storage system, installed [119](#)
- disaster recovery
 - Copy Services [76](#)
- disk drive
 - cable [82](#)
- disk drive module
 - maintenance policy [52](#)
- disk drive sets [82](#)
- disk enclosures
 - fillers [82](#)
- disk intermix
 - configuration indicators [81](#)
- Disk Manager
 - monitoring performance [17](#)
- drive enclosures [83](#)
- drive set
 - capacity [84](#)
- drive sets [82](#)
- drives
 - cable [83](#)
 - capacity calculation [84](#)
- DS command-line interface [16](#)
- DS8000 Storage Management GUI [16](#)
- dynamic expansion
 - volume [62](#)
- dynamic volume expansion [62](#)

E

- EAM [56](#)
- earthquake preparedness [140](#)
- earthquake resistance kit
 - required preparation for [121](#), [126](#)

- Easy Tier
 - overview [65](#)
- EAV CKD
 - 1 TB IBM Z CKD [58](#)
 - 3390 Model A [58](#)
 - cylinder size [58](#)
- enclosure fillers
 - feature codes [83](#)
- encryption
 - overview [79](#)
 - planning for [149](#), [150](#)
- Encryption Authorization [100](#)
- Entitled Systems Support (ESS) [158](#)
- environment
 - air circulation [134](#)
 - operating requirements [134](#)
- environmental notices [188](#)
- ESE capacity controls [64](#)
- ESE volumes [65](#)
- ESS, Entitled Systems Support [158](#)
- exhaust [132](#)
- expansion model position
 - configuration indicators [81](#)
- extended address volumes
 - overview [58](#)

F

- failover and fallback [76](#)
- FB, fixed block [55](#)
- FCM [51](#)
- FDE [51](#)
- Feature Activation for IBM Disk Storage [158](#)
- feature codes
 - additional setup options [95](#)
 - drive enclosures [83](#)
 - drive sets [82](#)
 - enclosure fillers [83](#)
 - features, other configuration [95](#)
 - Fibre Channel cable [88](#)
 - Fibre Channel host adapters [87](#)
 - flash drives [82](#)
 - flash RAID adapters [91](#)
 - I/O (RIO-G) cables [86](#)
 - I/O adapter [86](#)
 - I/O enclosures [86](#)
 - memory [92](#)
 - optional [95](#)
 - ordering optional features [81](#)
 - overhead cable management [89](#), [113](#)
 - physical configuration [81](#)
 - power cords [93](#)
 - power features [94](#)
 - processors [92](#)
 - setup [95](#)
 - shipping [95](#)
 - shipping and setup [95](#)
 - Transparent cloud tiering adapters [91](#)
 - zHyperLink cable [90](#)
 - zHyperLink I/O adapters [90](#)
- feedback, sending [ix](#)
- Fibre Channel
 - host adapters [87](#)
 - host adapters feature codes [87](#)

- Fibre Channel (*continued*)
 - host attachment [141](#)
 - open-systems hosts [53](#)
 - SAN connections [53](#)
- Fibre Channel cable
 - feature codes [88](#)
- fire suppression [140](#)
- fixed block storage [55](#)
- flash copy [77](#)
- flash drives [51](#), [82](#)
- flash drives, feature codes [82](#)
- flash RAID
 - adapters feature codes [91](#)
- FlashCopy
 - Multiple incremental FlashCopy [72](#)
- FlashCore Modules [51](#)
- floor and space requirements [109](#)
- floor load [117](#)
- force option [56](#), [63](#)

G

- GDPR [171](#)
- General Data Protection Regulation [171](#)
- Global mirror [105](#)
- Global Mirror [76](#), [77](#)

H

- HA intermix [52](#)
- hardware features [21](#)
- hardware planning [21](#)
- High Performance FICON [102](#)
- high-voltage
 - installations [131](#)
- homologation [176](#)
- host adapters
 - Fibre Channel [87](#)
- host attachment
 - overview [52](#)
- host systems
 - communication requirements [141](#)
- hot spot management [65](#)
- how to order using feature codes [81](#)
- HyperPAV [102](#)

I

- I/O adapter
 - features [86](#)
- I/O cable
 - configuration [86](#)
- I/O enclosure [52](#)
- I/O enclosures
 - feature codes [86](#)
- I/O load, balancing [54](#)
- I/O plug order [52](#)
- IBM Copy Services Manager
 - copy services [17](#)
 - Replication [17](#)
- IBM Spectrum Control [17](#)
- IBM Z
 - HyperPAV [102](#)

- IBM Z (*continued*)
 - parallel access volume [102](#)
 - Parallel Access Volumes [102](#)
- IBM Z hosts
 - FICON attachment overview [54](#)
- IEC 60950-1 [176](#)
- implementation, RAID [13](#)
- initialization [58](#)
- input voltage
 - configuration rules [94](#)
- input voltage requirements [130](#)
- installation
 - air circulation [138](#)
 - components with shipment [165](#)
 - nonraised floor [110](#)
 - raised floor [110](#)
- installation planning [107](#)
- IOPS [65](#)

L

- labels [184](#), [187](#)
- labels, safety information [176](#)
- LFF [51](#)
- licensed functions
 - Copy Services [79](#)
- licenses
 - function authorization documents [158](#)
- logical subsystems
 - overview [14](#)
- logical volumes [56](#)
- low-voltage
 - installations [131](#)
- LSS, logical subsystem [14](#)
- LUN
 - calculation [57](#)
 - control switch settings [145](#)

M

- machine types [2](#)
- maintenance policy
 - disk drive module [52](#)
- managed allocation [15](#)
- management console
 - multiple storage systems [50](#)
 - network settings [143](#)
 - overview [50](#)
 - TCP/IP ports [141](#)
- management interfaces [16](#)
- Media threshold [145](#)
- memory
 - feature codes [92](#)
 - system memory [92](#)
- Metro mirror [105](#)
- Metro/Global mirror [105](#)
- migrating data
 - selecting method [147](#)
- Multiple incremental FlashCopy [72](#)

N

- network settings [143](#)

- new features [xi](#)
- nodes [141](#)
- noise level [132](#)
- notices
 - caution [177](#)
 - danger [183](#)
 - environmental [188](#)
 - labels [184](#), [187](#)
 - safety [176](#)
- notification settings
 - methods [144](#)
- NVMe [51](#)

O

- obtaining activation codes [158](#)
- operating environment
 - power on [135](#)
 - while in storage [134](#)
 - with power on or off [134](#)
- Operating environment license [101](#)
- overview
 - host attachment [52](#)

P

- Parallel Access Volumes
 - understanding static and dynamic [68](#)
- pass-through [77](#)
- PAV (Parallel Access Volumes) [68](#)
- performance gathering
 - Disk Manager [17](#)
- physical configuration
 - drive capacity [84](#)
 - drive enclosures [83](#)
 - I/O adapter features [86](#)
 - I/O cable [86](#)
 - I/O enclosures [86](#)
 - power cords [93](#)
 - power features [94](#)
 - processors [92](#)
- planning
 - activating
 - full-disk encryption [150](#)
 - disk encryption
 - activating [150](#)
 - planning [150](#)
 - earthquake resistance kit site preparation [121](#), [122](#), [126](#)
 - encryption [149](#), [150](#)
 - environment requirements [134](#)
 - floor load [117](#)
 - full-disk encryption activation [150](#)
 - IBM Security Guardium Key Lifecycle Manager [149](#), [150](#)
 - IBM Storage Appliance 2421 Model AP1 [150](#)
 - isolated key servers [150](#)
 - network and communications [140](#)
 - operating environment, power [135](#)
 - power connector [131](#)
 - safety [139](#)
 - storage complex setup [143](#)
 - weight [117](#)
- point-in-time copy [105](#)

- pool rebalancing [65](#)
- power
 - consumption [132](#)
 - operating environment, off [135](#)
 - operating environment, on [135](#)
 - outlet requirements [130](#)
- power connector
 - requirements [131](#)
 - specifications [131](#)
- power cords
 - feature codes [93](#)
 - power connector [131](#)
- power features
 - configuration rules [94](#)
- power frequencies [130](#)
- Preparing a raised floor for the earthquake resistance kit
 - installation earthquake resistance kit
 - required preparation for [122](#)
- Present SIM data to all hosts [145](#)
- processor
 - feature codes [92](#)
 - memory (cache) [92](#)
- processors
 - feature codes [92](#)
- provisioned capacity
 - overview [57](#)
- publications
 - product [vii](#)
 - related [vii](#)

Q

- quick initialization [58](#)

R

- RAID
 - disk groups [54](#)
 - implementation [13](#)
 - RAID 10 overview [14](#)
 - RAID 6 overview [14](#)
 - RAID overview [13](#)
- raised floors
 - cutting tiles for cables [114](#)
- rank depopulation [65](#)
- Remote mirror and copy [105](#)
- remote power control [141](#)
- remote support
 - connections [141](#)
 - settings [144](#)
- replication
 - copy services functions [17](#)
- requirements
 - floor and space [109](#)
 - floor load [117](#), [119](#)
 - host attachment communication [141](#)
 - input voltage [130](#)
 - loading dock [108](#)
 - planning network and communications [140](#)
 - power connectors [131](#)
 - power outlets [130](#)
 - receiving area [108](#)
 - service clearance [120](#)

requirements (*continued*)
space [119](#)
resource groups
copy services [77](#)
RGL [77](#)
RIO-G cable [86](#)
rotate capacity [15](#)
rotate volumes [15](#)

S

safety
earthquake preparedness [140](#)
earthquake resistance kit [121](#), [122](#), [126](#)
fire suppression [140](#)
information labels [176](#)
notices [176](#)
operating environment [140](#)
power outlets [130](#)
service navigation [140](#)
temperature and cooling [140](#)
SAN
connections with Fibre Channel adapters [53](#)
SAS [51](#)
SAS enterprise and NL SAS [65](#)
scenarios
adding storage [159](#)
scope limiting
disaster recovery [77](#)
security
best practices
service accounts [152](#)
user accounts [151](#)
serial number setting [145](#)
service clearance requirements [120](#)
Service Information Messages [145](#)
service navigation [140](#)
SFF [51](#)
shipments
authorized service components [166](#)
container weight, dimensions [108](#)
hardware, software [165](#)
loading ramp [108](#)
media [166](#)
planning for receipt [108](#)
receiving area [108](#)
requirements
loading ramp [108](#)
shipping containers [108](#)
SIM [145](#)
slot plug order [52](#)
space release [63](#)
space requirements [119](#)
specifications
power connectors [131](#)
standards
air quality [136](#)
Standby CoD disk drives [83](#)
statement of limited warranty [163](#)
storage area network
connections with Fibre Channel adapters [53](#)
storage features
configuration rules [83](#)
storage image

storage image (*continued*)
cooling [138](#)
storage system
architecture [2](#)
implementation [2](#)
service clearances [120](#)
storage-enclosure fillers [83](#)
storage, consolidating [55](#)
System i
control switch settings [145](#)

T

T10 DIF
ANSI support [55](#)
Data Integrity Field [55](#)
FB LUN [55](#)
FB LUN protection [55](#)
FB volume [55](#)
Linux on z Systems [55](#)
SCSI end-to-end [55](#)
standard protection [55](#)
z Systems [55](#)
Taiwan BSMI certificate [95](#)
terminology [vii](#)
thermal load [132](#)
thin provisioning
ESE capacity controls [64](#)
overview [63](#)
thin provisioning and Easy Tier [65](#)
three tiers [65](#)
tiles, perforated for cooling [138](#)
Tivoli Storage Productivity Center [50](#)
top exit
bracket [112](#), [114](#)
measurements [112](#), [114](#)
overhead cable management [112](#), [114](#)
placement [112](#), [114](#)
top exit bracket
feature codes [89](#), [113](#)
trademarks [176](#)
transparent cloud tiering [61](#), [103](#)
Transparent cloud tiering
adapters feature codes [91](#)

U

understanding fixed block (FB) architecture [55](#)
understanding logical volumes [56](#)
user interfaces [16](#)

V

VMware
Array Integration support [67](#)
restrictions [67](#)
volume deletion
force option [63](#)
safe option [63](#)
volume migration [65](#)
volume rebalancing [65](#)
volumes
allocation [15](#), [56](#)

volumes (*continued*)
deletion [56](#)
force option [56](#)
modification [56](#)

W

warranty [163](#)
websites [vii](#)
weight
 floor load capacity [117](#)
 storage system, installed [119](#)
weight and dimensions
 shipping container [108](#)
worksheets
 -provided equipment [165](#)
 configuration [167](#)
 customization [167](#)
WWID, switch settings [145](#)

Z

z-synergy Services license
 High Performance FICON [102](#)
 HyperPAV [102](#)
 Parallel Access Volumes [102](#)
 transparent cloud tiering [103](#)
z/OS Distributed Data Backup
 [103](#)
 zHyperLink [103](#)
zHyperLink
 I/O adapters feature codes
 [90](#)
 z-synergy feature [103](#)
zHyperLink cable
 feature codes [90](#)



Printed in USA

G10-I53-00

