

5.4

*IBM OMEGAMON for Db2 Performance
Expert on z/OS
ISPF Client User's Guide*



2023-10-26 edition

This edition applies to Version 5 Release 4 of IBM® OMEGAMON for DB2® Performance Expert on z/OS (product number 5655-W37) and to all subsequent releases and modifications until otherwise indicated in new editions.

© **Copyright International Business Machines Corporation 2005, 2022.**

US Government Users Restricted Rights – Use, duplication or disclosure restricted by GSA ADP Schedule Contract with IBM Corp.

© **Rocket Software Inc. 2016, 2022 .**

Contents

About this information.....	vii
Chapter 1. Overview.....	1
Service updates and support information.....	1
How to read syntax diagrams.....	1
Conventions.....	2
Terminology.....	3
Accessibility features.....	4
Chapter 2. About ISPF Online Monitor.....	5
Required authority.....	5
Accessing the ISPF Online Monitor.....	6
Main menu.....	6
Display Thread Activity.....	6
Display Statistics.....	6
Display System Parameters.....	6
Options.....	7
Collect Report Data - General.....	7
Collect Report Data - For Buffer Pool Analysis.....	7
Create and execute reporting commands.....	7
Maintain parameter data sets.....	7
Explain.....	7
Options.....	8
Db2 Subsystem windows.....	8
History Defaults window.....	10
Monitor Output window.....	11
Auto Display window.....	11
Session options.....	12
Current SQLID window.....	13
Online Monitor Memory Usage window.....	13
Input data from Db2 monitor traces.....	14
Moving between panels.....	14
Updating values.....	15
Leaving the ISPF Online Monitor.....	15
Function key default settings.....	16
Issuing Db2 commands.....	18
Using the COLLECT command.....	20
Using the OPTIONS command.....	20
Correlation ID translation.....	20
The default translation.....	21
Changing the default translation.....	21
How large and missing values are displayed.....	21
Elapsed time formats.....	22
Date formats.....	23
Displaying long names and values in scrollable fields.....	23
Chapter 3. Monitoring and tuning.....	25
Changed access path to the ISPF Online Monitor.....	26
Performance data generation and online monitoring.....	26
The Db2 operating environment.....	27

Performance objectives and exception processing.....	27
Monitoring performance.....	27
Monitoring using reports.....	28
Monitoring using the ISPF Online Monitor.....	28
Observing performance trends.....	28
Determining performance problems.....	29
Problems detected in periodic exception processing.....	29
Problems detected in exception event processing.....	29
Problems detected in exception reports.....	29
Viewing past data.....	30
Exception processing.....	32
Exception processing modes.....	32
Exception Notification window.....	34
Difference between batch and Online Monitor exception processing.....	34
How to define exception threshold values.....	35
How to start exception processing.....	35
How to restart exception processing (REINIT command).....	38
Examining exception messages (LOOK command).....	39
Exception processor output data sets.....	43
Stopping exception processing.....	44
Displaying thread activity.....	44
Display Thread Activity overview.....	45
Thread Summary panel.....	48
Thread Detail panel.....	51
Thread Activity windows.....	53
Thread Activity commands.....	80
Viewing Db2 statistics.....	89
Statistics processing modes.....	90
Statistics panel overview.....	93
Db2 Statistics Detail panel.....	93
Db2 Statistics windows.....	95
Statistics commands.....	127
Monitoring the access path with Explain.....	130
Authorizations required to use Explain.....	130
Performance considerations.....	130
What to look for in Explain information.....	130
Plan table considerations.....	131
Explain an SQL statement.....	132
Explain Menu.....	133
Explain output (Db2 Explain Output panel).....	139
Online Monitor EXPLAIN command.....	141
ISPF Online Monitor Source Explain.....	141
Viewing system parameters.....	144
Db2 System Parameters panel.....	145
System Parameters commands.....	145
Problem identification examples.....	146
Example of exception processing.....	146
Example of thread monitoring.....	155
Using the ISPF Online Monitor in deadlock resolution.....	159
Application development and capacity planning.....	160
Chapter 4. Understanding common errors.....	161
STEPLIB missing from IRF-generated JCL.....	161
Chapter 5. Additional Information.....	163
Online Monitor field table.....	163
Layout of the Exception Log File output record.....	197

Product legal notices.....	201
Index.....	205

About this information

IBM OMEGAMON for Db2 Performance Expert on z/OS (also referred to as OMEGAMON for Db2 Performance Expert) is a performance analysis, monitoring, and tuning tool for Db2 on z/OS® environments.

The document is part of the OMEGAMON for Db2 Performance Expert documentation library which provides instructions for installing, configuring, and using OMEGAMON for Db2 Performance Expert and is designed to help database administrators, system programmers, application programmers, and system operators perform these tasks:

- Plan for the installation of OMEGAMON for Db2 Performance Expert
- Install and operate OMEGAMON for Db2 Performance Expert
- Customize your OMEGAMON for Db2 Performance Expert environment
- Diagnose and recover from OMEGAMON for Db2 Performance Expert problems
- Design and write applications for OMEGAMON for Db2 Performance Expert
- Use OMEGAMON for Db2 Performance Expert with other DB2 products

Chapter 1. Overview

IBM OMEGAMON for Db2 Performance Expert on z/OS (OMEGAMON for Db2 Performance Expert) enables you to monitor, analyze, and tune the performance of your Db2 subsystems and Db2 applications.

Service updates and support information

Service updates and support information for this product, including software fix packs, PTFs, frequently asked questions (FAQs), technical notes, troubleshooting information, and downloads, are available from the web.

To find service updates and support information, see the following website:

<https://www.ibm.com/support/pages/omegamon-xe-db2-pepm-web-based-delivery-and-updates-windows-and-unix-based-components>

How to read syntax diagrams

The rules in this section apply to the syntax diagrams that are used in this publication.

Arrow symbols

Read the syntax diagrams from left to right, from top to bottom, following the path of the line.



Two right arrows followed by a line indicate the beginning of a statement.



One right arrow at the end of a line indicates that the statement syntax is continued on the next line.



One right arrow followed by a line indicates that a statement is continued from the previous line.



A line followed by a right arrow and a left arrow indicates the end of a statement.

Conventions

- SQL commands appear in uppercase.
- Variables appear in italics (for example, *column-name*). They represent user-defined parameters or suboptions.
- When entering commands, separate parameters and keywords by at least one blank if there is no intervening punctuation.
- Enter punctuation marks (slashes, commas, periods, parentheses, quotation marks, equal signs) and numbers exactly as given.
- Footnotes are shown by a number in parentheses, for example, (1).

Required items

Required items appear on the horizontal line (the main path).



Optional items

Optional items appear below the main path.

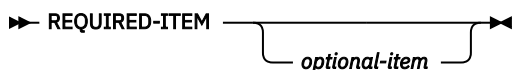

If an optional item appears above the main path, that item has no effect on the execution of the statement and is used only for readability.



Multiple required or optional items

If you can choose from two or more items, they appear vertically in a stack. If you *must* choose one of the items, one item of the stack appears on the stack main path.

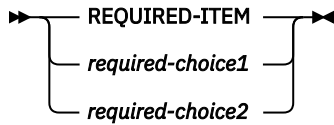

If choosing one of the items is optional, the entire stack appears below the main path.

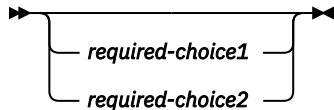

Repeatable items

An arrow returning to the left above the main line indicates that an item can be repeated.

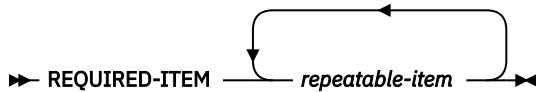

If the repeat arrow contains a comma, you must separate repeated items with a comma.

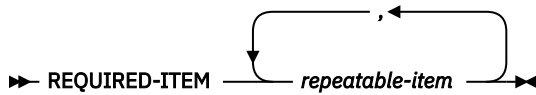

If the repeat arrow contains a number in parenthesis, the number represents the maximum number of times that the item can be repeated.

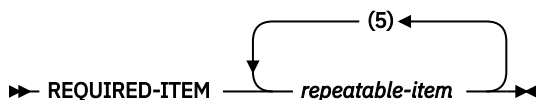

A repeat arrow above a stack indicates that you can specify more than one of the choices in the stack.

Default keywords

IBM-supplied default keywords appear above the main path, and the remaining choices are shown below the main path. In the parameter list following the syntax diagram, the default choices are underlined.

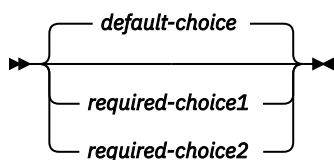

Conventions

These conventions are used throughout the documentation.

Symbols

The following symbols might appear in command syntax:

Symbol	Usage
	<p>The or symbol is used to denote a choice. You can use the argument on the left or the argument on the right. For example:</p> <pre>YES NO</pre> <p>In this example, you can specify YES or NO.</p>
()	<p>Denotes optional arguments. Arguments that are not enclosed in square brackets are required. For example:</p> <pre>APPLDEST DEST (ALTDEST)</pre> <p>In this example, DEST is a required argument and ALTDEST is optional.</p>
{ }	<p>Some documents use braces to denote mandatory arguments, or to group arguments for clarity. For example:</p> <pre>COMPARE {workload} - REPORT={SUMMARY HISTOGRAM}</pre> <p>In this example, the workload variable is mandatory. The REPORT keyword must be specified with a value of SUMMARY or HISTOGRAM.</p>
-	<p>Default values are underscored. For example:</p> <pre>COPY infile outfile - [COMPRESS={<u>YES</u> NO}]</pre> <p>In this example, the COMPRESS keyword is optional. If specified, the only valid values are YES or NO. If omitted, the default is YES.</p>

Notation conventions

The following conventions are used when referring to high-level qualifiers:

hilev

A high-level qualifier. The high-level qualifier is the first prefix or set of prefixes in the data set name. Site-specific high-level qualifiers are shown in italics.

For example:

- *thilev* refers to the high-level qualifier for your target data set.
- *rhilev* refers to the high-level qualifier for your runtime data set.

For members in target libraries, the high-level qualifier is *thilev* rather than *rhilev*.

- *shilev* refers to the SMP/E library high-level qualifier.

Terminology

The following table shows the products that are described in this publication and the short names with which they are referred to throughout this publication.

<i>Table 1. Product names and their short names</i>	
Product name	Short name
IBM OMEGAMON for Db2 Performance Expert on z/OS	OMEGAMON for Db2 Performance Expert

Accessibility features

Accessibility features help a user who has a physical disability, such as restricted mobility or limited vision, to use a software product successfully.

The major accessibility features in this product enable users to perform the following activities:

- Use assistive technologies such as screen readers and screen magnifier software. Consult the assistive technology documentation for specific information when using it to access z/OS interfaces.
- Customize display attributes such as color, contrast, and font size.
- Operate specific or equivalent features by using only the keyboard. Refer to the following publications for information about accessing ISPF interfaces:
 - *z/OS ISPF User's Guide, Volume 1*
 - *z/OS TSO/E Primer*
 - *z/OS TSO/E User's Guide*

These guides describe how to use the ISPF interface, including the use of keyboard shortcuts or function keys (PF keys), include the default settings for the PF keys, and explain how to modify their functions.

Chapter 2. About ISPF Online Monitor

When you invoke the ISPF Online Monitor by selecting option 3 on the OMEGAMON® XE for Db2 PE main menu, the Online Monitor Main Menu is displayed.

The Online Monitor Main Menu provides access to functions through sets of menus and panels.

```
05/07/08 17:13      Online Monitor Main Menu      PM06D861 D861  V10
Select one of the following.
--  1.  Display Thread Activity
    2.  Display Statistics
    3.  Display System Parameters
    4.  Options
    5.  Control Exception Processing
    6a. Collect Report Data - General
    6b. Collect Report Data - For Buffer Pool Analysis
    7.  Create and execute reporting commands
    8.  Maintain parameter data sets
    9.  Explain

Command ===>-----
F1=Help   F2=Split  F3=Exit   F9=Swap   F12=Cancel
```

Figure 1. Online Monitor Main Menu

Considerations

The following ISPF Online Monitoring functions are not supported for Db2 11 or later:

- Display Thread Activity (option 3.1)
- Display Statistics (option 3.2)
- Display System Parameters (option 3.3)

Real time monitoring is provided by the Classic User Interface. For more information, see <https://www.ibm.com/docs/en/om-db2-pe/5.4.0?topic=classic-user-interface>.

Required authority

The information in this section applies only if you do not use the user authorization exit.

If the user exit is active, the description about the user authorization exit provided in *IBM Db2 for z/OS in the IBM Knowledge Center* applies.

To use the Online Monitor, you need the following authorities:

- Access to a Db2 subsystem
- EXECUTE authority on the Online Monitor plan. The plan name is KO2PLAN.
- MONITOR1 privilege
- Display trace privilege

You also need the Db2 authority for any Db2 commands you issue.

The following authorities are recommended:

- MONITOR2 or SYSADM privilege if you need access to the currently executing SQL statement
- Db2 privilege to start or stop a Db2 trace, if you want to collect report data

Important: Granting MONITOR2 privilege enables access to potentially sensitive data, for example, the SQL statement being executed.

Accessing the ISPF Online Monitor

To access the ISPF Online Monitor, start your IBM Tivoli® OMEGAMON XE for Db2 Performance Expert on z/OS session from the TSO/ISPF environment (Start EXEC FPEJINIT).

When the IBM Tivoli OMEGAMON XE for Db2 Performance Expert on z/OS main menu (see [Figure 18](#) on page 26) is displayed, select option 3 (View online DB2 activity - PE ISPF OLM). This presents the Online Monitor Main Menu (see [Figure 1](#) on page 5).

Main menu

This section outlines the privileges and traces required to use the ISPF Online Monitor, shows how to change parameters that affect the behavior of an Online Monitor session, describes the online help, the default function key settings, how to move between Online Monitor panels, how to issue Db2 commands, global commands, and how to treat some common errors.

Display Thread Activity

Use this option to view detailed thread and locking information for all threads that are currently connected to a Db2 subsystem.

Note: This function is not supported for Db2 11 or later. Real time monitoring is provided by the Classic User Interface. For more information, see <https://www.ibm.com/docs/en/om-db2-pe/5.4.0?topic=classic-user-interface>.

You can view active threads in a summary format, or examine them individually in greater detail.

When you select this option, the Thread Summary panel is displayed, listing all active threads. You can filter the list by using the QUALIFY command. You can also sort the list by using the SORT command. You can select any active thread to display the Thread Detail panel, where you can examine the thread.

The Thread Detail panel provides an overview of key values for the selected thread. From the Thread Detail panel, you can access additional windows to view thread activity data in greater detail.

The headings, field labels, fields displayed, and the order they appear in the Thread Detail panel can be tailored.

Display Statistics

Use this option to view important statistics and ratios of a Db2 subsystem in a summary format or in detail.

Note: This function is not supported for Db2 11 or later. Real time monitoring is provided by the Classic User Interface. For more information, see <https://www.ibm.com/docs/en/om-db2-pe/5.4.0?topic=classic-user-interface>.

When you select this option, the Db2 Statistics Detail panel is displayed providing an overview of key statistics values for the system. From this panel, you can access additional windows to view statistics data in greater detail.

The headings, field labels, fields displayed, and the order they appear in the Db2 Statistics Detail panel can be tailored.

Display System Parameters

Use this option to view an overview of the current DSNZPARM values in effect for a Db2 subsystem including any changes to the buffer pool and group buffer pool parameters.

Note: This function is not supported for Db2 11 or later. Real time monitoring is provided by the Classic User Interface. For more information, see <https://www.ibm.com/docs/en/om-db2-pe/5.4.0?topic=classic-user-interface>.

When you select this option, the Db2 System Parameters panel is displayed providing an overview of key system parameter values. From this panel, you can access additional windows providing system parameters information in greater depth.

The headings, field labels, fields displayed, and the order they appear in the Db2 System Parameters panel can be tailored.

Options

You can use options to change the parameters affecting the behavior of your own Online Monitor session.

For example, you might want to specify the following options:

- Select the Db2 subsystem to be monitored.
- Display your installation-specific history parameters (only available if the data collector is installed at your site).
- Control the writing of monitor records to an output data set.
- Set the default auto-display interval.
- Set several Interactive Report Facility (IRF) session options.
- Set the current SQLID for Explain processing.
- Allocate a larger storage area for thread summary information, if the default size is not sufficient.

Collect Report Data - General

Use this option to start and stop Db2 traces either manually or automatically by specified triggers. The resulting trace data can be directed to a data set for immediate input to batch reporting. The Db2 traces required are determined by the reports that you want to produce.

See the [Reporting User's Guide](#) for more information.

Collect Report Data - For Buffer Pool Analysis

Use this option to collect data for the buffer pool analysis function. The collected data is used to report buffer pool efficiency, and to simulate the effects buffer pool tuning actions before altering a buffer pool's characteristics.

See the [Buffer Pool Analyzer User's Guide](#) for more information.

Create and execute reporting commands

This option invokes the Interactive Report Facility (IRF), which you can use to interactively create and execute batch report command streams.

See the [Reporting User's Guide](#) for the description of the IRF and the [Report Reference](#) for reports generated by using the IRF.

Maintain parameter data sets

Use this option to maintain the Exception Threshold data set, the correlation translation member, the timezone information member, and the MAINPACK definition member.

See the [Reporting User's Guide](#) for more information.

Explain

Use this option to examine the access path method chosen by Db2 for a given SQL statement in an easy-to-read format. The SQL statement you want to explain can be an existing entry in a specific

PLAN_TABLE, an SQL statement from a previously bound plan or package, or a dynamically entered SQL statement.

You can view detailed information about packages, DBRMs, tables, indexes, and the SQL text. The SQL statement can be modified for online tuning.

You can also explain an SQL statement from within the thread activity function to explain a currently executing SQL statement, or from within an ISPF/PDF editor to explain an SQL statement imbedded in a source program or SPUFI input.

See [“Monitoring the access path with Explain”](#) on page 130 for more information.

Options

Use the Options panels to change parameters affecting the behavior of your Online Monitor session. To display the Options menu, select option 4 (Options) from the Online Monitor Main Menu.

```
DGOMDPMN 13:13          Options          PM01DL0C DSN1 V10
Select one of the following.
--  1.  DB2 Subsystem
    2.  History Defaults
    3.  Monitor Output
    4.  Auto Display
    5.  Session Options
    6.  Current SQLID
    7.  ISPF Online Monitor Memory Usage

Command ==> -----
F1=Help    F2=Split    F3=Exit    F9=Swap    F12=Cancel F16=Look
F17=Collect
```

Figure 2. Options menu

You can select one of the following options from this menu:

- Select option 1 (DB2 Subsystem) to display either the Db2 Subsystems List window or Db2 Subsystem window, where you can select the Db2 subsystem to be monitored.
- Select option 2 (History Defaults) to display the History Defaults window, where you can display the installation-specified history defaults. This option is available only if a data collector is active for the Db2 subsystem you are monitoring.
- Select option 3 (Monitor Output) to display the Monitor Output window, where you can control the writing of monitor records to an output data set.
- Select option 4 (Auto Display) to display the Auto Display window, where you can set the default interval for the AUTO command.
- Select option 5 (Session Options) to display the Session Options window, where you can set several options controlling the environment of your IRF session.
- Select option 6 (Current SQLID) to display the Current SQLID window, where you can specify a different SQL authorization ID for qualifying the unqualified tables in the statements being explained.
- Select option 7 (ISPF Online Monitor Memory Usage) to increase the default size of the internal storage area for displaying thread summary information from 1 MB to up to 4 MB. This might become necessary in large environments, if the amount of active Db2 threads cannot be displayed in the Thread Summary panel (typically revealed by message FPEM103 or FPEM546).

Db2 Subsystem windows

Use the Db2 Subsystems List window to select the Db2 subsystem to be monitored.

Only the Db2 subsystems with data collectors started within the MVS system are listed on the Db2 Subsystems List window.

To display this window, select **Option 1 (DB2 Subsystem)** from the Options menu.

```

DGOMDWSL                DB2 Subsystems List                ROW 1 TO 3 OF 3
Select the Data Collector to use or specify a DB2 subsystem ID
DB2 Subsystem  DSN1
-   Data Collector DB2 Location          DB2 Release
-   DSNB           PM01DB11             V10
-   DSNC           PM01DC11             V10
***** BOTTOM OF DATA *****

Command ==> _____ Scroll ==> CSR
F1=Help   F2=Split  F7=Up      F8=Down   F9=Swap   F12=Cancel
F16=Look  F17=Collect

```

Figure 3. Db2 Subsystems List window

The following columns are shown:

Data Collector

The data collector identifier.

Db2 Location

The location as obtained from the trace records for the data collector.

Db2 Release

The Db2 release level.

To monitor a Db2 subsystem that has an active data collector running, enter any character in the input field beside a data collector Db2 location and press Enter.

To monitor a Db2 subsystem that does not have an active data collector running, enter the name of the Db2 subsystem in the DB2 Subsystem field and press Enter.

If no data collectors are active on your MVS system, the Db2 Subsystem window is displayed instead.

Note: The version and release numbers of the Db2 load library allocated to the Online Monitor session must match the version and release numbers of the Db2 subsystems being monitored.

```

DGOMDWS1                DB2 Subsystem
Enter the subsystem ID of the DB2 subsystem to monitor and
press Enter.
DB2 Subsystem  ____

F1=Help   F2=Split  F9=Swap   F12=Cancel

```

Figure 4. Db2 Subsystem window

If the data collector is not installed at your site or the monitored Db2 subsystem does not have an active data collector running, the following Online Monitor functions are not available:

- Viewing past data
- Periodic exception processing while you are not logged on
- Exception event processing
- Collection of parallel tasks for query CP parallelism

Changing Db2 subsystems terminates all asynchronous tasks that were started using the Online Monitor. If you change Db2 subsystems while an asynchronous task is active, you are notified by the Asynchronous Task Termination panel.

If you work in split screen mode and you change the subsystem in one session, asynchronous tasks are terminated even if they were activated in the other session.

```

DGOMGP03      Asynchronous Task Termination

Press Enter to change Subsystem or request Cancel to restore the
Subsystem ID to its previous value.

Changing the Subsystem results in the termination of all active
tasks as well as the stopping of all the DB2 traces started by the
Collect Report Data facility.

Exception/Collect tasks      Status
-----
Periodic Exception          Active
Exception Event             Not active

Collect data for acct/io/stats/audit   Active
CICS problem                  Active
Collect Task C                Not active
Collect Task D                Not active

Command ==> -----
F1=Help      F2=Split      F3=Exit      F9=Swap      F12=Cancel  F16=Look
F17=Collect

```

Figure 5. Asynchronous Task Termination panel

To change Db2 subsystems, press Enter. All asynchronous tasks are terminated.

To return to the previous panel without changing Db2 subsystems, press F3 (Exit) or F12 (Cancel). All active asynchronous tasks remain active.

History Defaults window

Use the History Defaults window to view the history parameters that are currently in effect.

To display this window, select option 2 (History Defaults) from the Options menu.

```

DGOMDWH      History Defaults      ROW 1 TO 6 OF 6

History Collected . . . . . : YES
History Interval . . . . . : 10

History From . . . . . : 04/05/08 13:30:36
History To . . . . . : Present

Data for which History is stored :
Statistics
System Parameters
Thread SQL Statement
Thread Summary
Thread Detail
Locked Resources
***** BOTTOM OF DATA *****

Command ==> -----
F1=Help      F2=Split      F3=Exit      F7=Up
F8=Down      F9=Swap      F12=Cancel  F16=Look
F17=Collect

```

Figure 6. History Defaults window

By using the HISTORY command, you can view thread activity, statistics, and system parameters data previously gathered by the data collector. See [“Viewing past data” on page 30](#) for a complete description about how to view past performance data.

The `History Collected` field shows either YES or NO to indicate if any past data is available.

The `History Interval` field indicates how often DB2 instrumentation data is being gathered by the data collector. This field is a numeric value in seconds.

The `History From` field shows the date and time of the earliest history data available.

The `History To` field shows the date and time of the most recent history data available.

The `Data for which History is stored` field lists the types of data gathered by the data collector. This list includes the data types specified at data collector startup and subsequent changes made by the administrator users. Statistics history keeps subsystem-wide statistical information for a Db2 subsystem. For thread activity you can collect thread history individually in a summary format, in detail format, or in detail format with locking information, SQL statement, or both. System Parameters history keeps an overview of DSNZPARM values for a Db2 subsystem.

For more information about viewing past data, see “[Viewing past data](#)” on page 30. For more information about data collector installation options, see [IBM Db2 for z/OS in the IBM Knowledge Center](#).

Monitor Output window

Use the Monitor Output window to enable or disable the writing of monitor output to a data set.

The main use of this option is to gather data for problem determination. Records in DPMOUT format that correspond to data shown in the Online Monitor panels are written to a data set whenever the display is updated. Output from the Statistics and System Parameters panels can be used as input to the Batch Statistics and System Parameter reports respectively. The output from the Thread Display panels can only be processed by a batch Record trace.

To display this window, select option 3 (`Monitor Output`) from the Options menu.

```
DGOMDWMO                Monitor Output

To write monitor output, enter 1 and dataset name and disposition

Write output . . . . . 2 1=yes 2=no

Dataset name . . . . . : _____
Disposition . . . . . : 1 1=append 2=overwrite 3=new

F1=Help   F2=Split   F9=Swap   F12=Cancel
```

Figure 7. Monitor Output window

Use the `Write output` field to specify whether you want monitor output written to a data set. Enter 1 in this field to enable the writing of monitor output to a data set.

The `Dataset name` field requires the name of the data set to which the data is to be written.

If you specify a disposition of 3 (new), the data set is dynamically allocated with the following attributes:

```
RECFM:
  VBS
LRECL:
  32 756
BLKSIZE:
  6 233
```

Auto Display window

Use the Auto Display window to set the auto-display refresh interval for data shown in the Online Monitor panels. When auto display is active, the values displayed in the current panel are updated periodically, as specified in the Auto Display window. If you activate auto-display mode while viewing past data, the panel is updated with subsequent past records at every auto-display interval. The time difference between

these records is determined by the history interval when the data was collected, and not by the current auto-display interval.

To display this window, select option 4 (Auto Display) from the Options menu.

```
DGOMDWAD          Auto Display
Update values then Enter
Units . . . . . 1 1=seconds
                  2=minutes
Interval . . . . . 10 1-7200 seconds
                  1-120 minutes

F1=Help   F2=Split   F9=Swap   F12=Cancel
```

Figure 8. Auto Display window

Use the Units field to specify the unit of time that is to be associated with the value in the Interval field.

Use the 1 field to specify how frequently the panels are refreshed when the AUTO command is issued.

To start auto-display mode, type AUTO on any Thread Activity or Statistics panel command line and press Enter. To stop auto-display mode, press the Attention key. You cannot perform any other actions with your Online Monitor session while auto-display mode is running.

Session options

Use the Session Options window to set several options controlling the environment of your Interactive Report Facility (IRF) session.

To display this window, select option 5 (Session Options) from the Options menu, or type OPTIONS on any command line and press Enter.

```
DGOF0PTS          Session Options
Update fields as required, then press Enter.
Confirmation display . . . . . 1 1=yes 2=no
Initial menu choice . . . . . 1 1-6 or blank
Execution mode . . . . . 1 1=Background
                          2=Foreground
                          3=Prompt

DPMPARMS data set . . . -----
F1=Help   F2=Split   F9=Swap   F12=Cancel
```

Figure 9. Session Options window

The field values shown in [Figure 9 on page 12](#) are the default settings.

Use the 1 field to specify whether or not you want to be prompted each time you issue a delete, replace, or reset request.

Use the 1 field to specify the panel you want to start on. Possible values for this field are:

- 1** Create and execute reporting commands (DGOOMENU)
- 2** View online Db2 activity - Classic Interface (KO2MPSPF)
- 3** View online Db2 activity - PE ISPF OLM (FPEMMENU)

- 4 View online Db2 activity - PE ISPF OLM (FPEMMENU)
- 5 Customize report and trace layouts (DGOBMENU)
- 6 Exception profiling (DGOFEP00)
- Blank**
Performance Expert main menu (FPEFMENU).

The 1 field applies to the execution of batch jobs.

Use the 1 field to specify the DPMPARMS data set to be used by the Online Monitor. The DPMPARMS data set contains information about exception thresholds, customized report layouts, time zone specifications, correlation ID translation, and the MAINPACK identifier. Only the correlation ID translation part is used by the Online Monitor.

Current SQLID window

Use the Current SQLID window to specify a different SQL authorization ID for qualifying the unqualified tables in the statements being explained if they do not belong to a plan or package. The Current SQLID window is also used to qualify the plan table to be accessed.

To display this window, select option 6 (Current SQLID) from the Options menu.

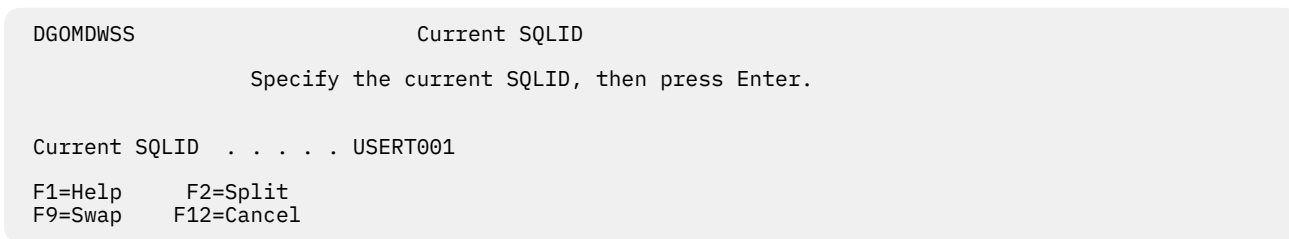

Figure 10. Current SQLID window

If the 1 field in this window is not specified, it defaults to your user ID.

Online Monitor Memory Usage window

Use the ISPF Online Monitor Memory Usage window to specify a different size of the internal storage area that the Online Monitor uses to display active thread information. You can specify a value of 1, 2, 3, or 4, which corresponds to 1 to 4 MB.

Typically, you only need to increase the size of this storage area if the Online Monitor complains about insufficient storage to display active thread information (message FPEM103 or FPEM546).

By default, the Online Monitor uses a 1 MB storage area. When you change the size, the change takes place when you select again option 3 (View online DB2 activity - PE ISPF OLM) from the OMEGAMON XE for Db2 PE main menu (shown in Figure 18 on page 26). The specified value becomes the new default value and remains in effect until it is replaced by a different value.

To display this window, select option 7 (ISPF Online Monitor Memory Usage) from the Options menu.

```
DGOMDMMU          ISPF Online Monitor Memory Usage

Specify the memory size, then press enter. Possible values are
1, 2, 3, or 4 (in MB).
Changes take place after reentering 'View online DB2 activity'.

Memory Pool Size . . . . . : 1

F1=Help   F2=Split   F3=Exit   F9=Swap   F12=Cancel
```

Figure 11. ISPF Online Monitor Memory Usage window

Input data from Db2 monitor traces

To use the Online Monitor, ensure that the Db2 monitor trace is active. Monitor trace class 1 is required to display data. Monitor trace classes 2, 3, 7, and 8 should also be activated.

As long as the monitor trace is active, there is no need to activate Db2 Statistics and Accounting traces.

Monitor trace class 2 provides Db2 processor and elapsed times for the Thread Activity panels and class 7 provides Db2 processor and elapsed times for packages. Monitor trace class 2 is also required for class 1 TCB time.

Monitor trace class 3 provides Db2 suspension times for the Thread Activity panels and class 8 provides Db2 suspension times for packages.

Note: The version and release numbers of the Db2 load library allocated to the Online Monitor session must match the version and release numbers of the Db2 subsystems being monitored.

To change the version of Db2 you are monitoring, exit from the Online Monitor and ISPF to reallocate the Db2 load library. For information about how to reallocate the Db2 load library at your site, consult your system programmer.

Moving between panels

When you have entered a command on the command line, or have entered the information required to complete a panel, press Enter.

To go back to a previous panel or menu, press F3 (Exit).

Each time you press Enter or F3 (Exit), data entered in that panel is validated. If an error is detected, an error message is displayed and the cursor is positioned on the field in error. If no error is detected, processing continues.

To leave a panel without saving the entries and return to the previous panel, or to cancel all windows, press F12 (Cancel).

You can move between various Online Monitor options by typing = followed by the Online Monitor Main Menu option number on the command line of any Online Monitor panel:

- =1** Jumps to Display Thread Activity
- =2** Jumps to Display Statistics
- =3** Jumps to Display System Parameters
- =4** Jumps to Options
- =5** Jumps to Control Exception Processing

- =6a**
Jumps to Collect Report Data - General
- =6b**
Jumps to Collect Report Data - For Buffer Pool Analysis
- =7**
Jumps to Create and execute reporting commands
- =8**
Jumps to Maintain parameter data sets
- =9**
Jumps to Explain
- =X**
Exits the Online Monitor

Updating values

To refresh Thread Activity, Statistics, and System Parameters panels with new data from Db2, press Enter.

Values are not updated if:

- Any OMEGAMON XE for DB2 PE or ISPF command is entered on the command line
- Windows™ are selected for display
- Function keys are used

Note: The values shown in the Thread Summary and Threads Holding Resource panels are refreshed automatically each time the panels are displayed.

Leaving the ISPF Online Monitor

To exit the ISPF Online Monitor from the Online Monitor Main Menu, press F3 (Exit) or F12 (Cancel). From any other Online Monitor panel, type =X on the command line and press Enter.

If any asynchronous tasks are active when you exit the Online Monitor, you are notified by one of the Asynchronous Task Termination panels. If the data collector is not active, the tasks are terminated when you exit the Online Monitor. If the data collector is active, you have the choice of leaving the selected tasks active or not when you exit the Online Monitor.

```

FPEMGP01           Asynchronous Task Termination
Command ===> -----

Press Enter to exit the Online Monitor or request Exit or Cancel to
return to the Online Monitor Main Menu.

Select an Exception task to keep it active. All non-selected tasks
will be terminated when leaving the Online Monitor as well as all the
DB2 traces started by the Collect Facility will be stopped.

Exception/Collect tasks           Status
-----
Periodic Exception                 Not active
Exception Event                   Not active

run 3pm today                     Active
run at 10 today                   Active
Collect Task C                    Not active
Collect Task D                    Not active
Collect Task for BPA              Not active
F1=Help      F2=Split      F3=Exit      F9=Swap      F12=Cancel
F17=Collect

```

Figure 12. Asynchronous Task Termination panel

To exit the Online Monitor from this window, press Enter. If the data collector is active, any tasks selected in this window remain active.

To return to the Online Monitor Main Menu, press F3 (Exit) or F12 (Cancel). All active tasks remain active.

Function key default settings

Use the function key default settings to view help, move between panels, or access certain Online Monitor and ISPF functions with a single keystroke.

Note:

- The Online Monitor is an ISPF application, and all normal ISPF behaviors apply.
- The default function key settings in help panels follow the standard conventions for help in the ISPF environment.

Table 2 on page 16 describes the Online Monitor function keys, their default settings, their functions, and the Online Monitor panels on which they are available.

Function key	Default setting	Function	Online Monitor panels
F1	HELP	Used to view help information for a panel or field.	All panels
F2	SPLIT	Used to divide the display into two logical displays separated by a horizontal line and starts another ISPF session, or changes the location of the horizontal line.	All panels
F3	EXIT	Used to validate and save the data entered in a panel, exit the panel, and return to the previous panel.	All panels that contain a command line
F4	PROMPT	Used to view a list of possible values for a field. The prompt fields are followed by a plus sign (+).	Some Collect Report Data panels and Exception Threshold Field Details panel
F5	AUTO	Used to refresh the data shown in the current panel periodically.	All Thread and Statistics panels
	ADD	Used to add a new exception threshold entry.	Exception Threshold Field Details panel
F6	HISTORY	Used for viewing historical data in panels. Note: If your installation has installed the Online Monitor without the data collector, this function is not available.	All Thread Activity, Statistics, and System Parameters panels
	DELETE	Used to delete an exception threshold entry.	Exception Threshold Field Details panel
F7	UP	Used to scroll toward the top of the data.	All scrolling panels
F8	DOWN	Used to scroll toward the bottom of the data.	All scrolling panels
F9	SWAP	Used to switch between ISPF sessions.	All panels

Table 2. Function key default settings (continued)

Function key	Default setting	Function	Online Monitor panels
F10	QUALIFY	Used to filter the threads listed in the Thread Summary panel.	Thread Summary panel
	DELTA	Used to begin delta processing mode that calculates the statistics values between the last two times you pressed Enter.	All Statistics panels
	PREVIOUS	Used to display the previous exception threshold entry for a field.	Exception Threshold Field Details panel
F11	SORT	Used to sort the threads listed in the Thread Summary panel.	Thread Summary panel
	INTERVAL	Used to establish a base point in time from which statistics are to be calculated.	All Statistics panels
	NEXT	Used to display the next exception threshold entry for a field.	Exception Threshold Field Details panel
F12	CANCEL	Used to exit a panel without saving the entries, and return to the previous panel canceling all related panels.	All panels
F14	PURGE	Used to purge a thread currently processing in the Db2 subsystem you are monitoring. You require the Db2 privilege to perform CANCEL THREAD.	All Thread Activity panels
F16	LOOK	Used to view the following exception information and authorization failures: <ul style="list-style-type: none"> • Periodic exceptions • Periodic exceptions messages • Display exceptions • Authorization failure summary • Exception event summary • Exception event messages 	All panels (except LOOK and related panels)
F17	COLLECT	Used to display the Collect Report Data panel, where you can collect specific Db2 instrumentation data and direct this data to a data set.	All panels (except Collect Report Data panels)
F18	EXPLAIN	Used to explain the access path methods chosen by Db2 for a given SQL statement.	All Thread panels that show the SQL statement
F19	LEFT	Used to scroll toward the left.	Thread Summary panel
F20	RIGHT	Used to scroll toward the right.	Thread Summary panel
F21	EXPAND	Used to expand a field content that is too long to fit in a panel into a separate window where the entire field content can be shown.	All panels that contain information of a length that cannot be shown in the available panel space.

Function key	Default setting	Function	Online Monitor panels
F22	LEFT	Used to scroll through a field content that is too long to fit in a panel, if the cursor is positioned on such a field.	All panels that contain information of a length that cannot be shown in the available panel space.
F22	RIGHT	Used to scroll through a field content that is too long to fit in a panel, if the cursor is positioned on such a field.	All panels that contain information of a length that cannot be shown in the available panel space.

You can use the following ISPF commands to alter the function key settings:

KEYLIST

Changes the function key settings.

FKA

Alternates between the function key long display format, short display format, and no function key display at all.

PFSHOW

Toggles on and off the display of function key settings.

PFSHOW TAILOR

Specifies how function keys are displayed.

All function keys correspond to a command entered on the command line. For example, typing the command CANCEL on the command line is the same as pressing the F12 (Cancel) key.

You can use the command line with the function keys to enter function parameters. To do this, type the parameters on the command line and press the function key to activate the command.

You can use the ISPF PANELID command to choose whether to display a panel ID on the top line of the panels. To toggle the panel ID display, type PANELID on the command line and press Enter.

Issuing Db2 commands

Use the command Db2 to execute any Db2 command during your Online Monitor session. You can enter this command on the command line of any Online Monitor panel.

The command syntax is:

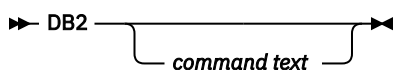

Figure 13. Syntax of the Db2 command

The Db2 command accepts the following parameter:

command text

The Db2 command you want to execute.

For example:

```
DB2 DISPLAY THREAD(*)
```

Type DB2 and the *command text* on the command line and press Enter. The Db2 Command Output window is overlaid on the current panel, where you can view the Db2 command output. An example of the Db2 Command Output window is shown in [Figure 14 on page 19](#).

```

DGOMTPLS 12:57          Thread Summary          ROW 1 TO 5 OF 5
PM01DLOC          DSN1 V10          GROUP001 MEMBER01

DGOMCDCO          DB2 Command Output          ROW 1 TO 12 OF 12
-----
- DSNV401I _ DISPLAY THREAD REPORT FOLLOWS -
- DSNV402I _ ACTIVE THREADS -
- NAME ST A REQ ID AUTHID PLAN ASID TOKEN N/P
- DB2CALL T 3 USER030 USER030 DB2PMOM 002B 25 N/P
- DB2CALL T 5 USER001 USER001 DB2PMOM 002E 10 N/P
- DB2CALL T * 6 USER023 USER023 DB2PMOM 0031 10
DB2CALL T 10 USER027 USER027 DB2PMOM 0082 20
DB2CALL T 5 USER040 USER040 DB2PMOM 0027 15
DB2CALL T 50 USER009 USER009 DB2PMOM 002D 15
DB2CALL T 4 USER009 USER009 DB2PMOM 002D 22
DISPLAY ACTIVE REPORT COMPLETE
DSN9022I _ DSNVDT '-DISPLAY THREAD' NORMAL COMPLETION
***** Bottom of data *****

Command ==> -----
F1=Help F2=Split F3=Exit F7=Up F8=Down F9=Swap
F12=Cancel F16=Look F17=Collect

Command ==> DB2 DISPLAY THREAD(*)
F1=Help F2=Split F3=Exit F5=Auto F6=History F7=Up
F8=Down F9=Swap F10=Qualify F11=Sort F12=Cancel F16=Look
F17=Collect F19=Left F20=Right F22=Purge

```

Figure 14. Db2 Command Output window

If you issue the command Db2 without any parameters, the Db2 Command window is displayed.

```

DGOMCCMD          DB2 Command

Enter DB2 Command below:

START TRACE(MON)_____
-----
-----
-----

Place cursor on choice and press Enter to retrieve command

=> start trace(perfm) class(6)
=> display thread(*)
=> display trace
=>
=>
=>
=>
=>
=>

Command ==> -----
F1=Help F2=Split F3=Exit F9=Swap F12=Cancel F16=Look
F17=Collect

```

Figure 15. Db2 Command window

This window displays command lines on which you can issue Db2 commands. The window shows a list of the last ten Db2 commands that you entered.

You can retrieve a command that is stored in the list by positioning the cursor under the command and pressing Enter. Then, the command is shown on the command line, where you can edit and then submit the command by pressing Enter again.

If a new or modified command is submitted, the command is added to the top of the list. If the command was not edited before submission, or the command was not submitted at all, the list is not updated.

Note: You cannot abbreviate the command Db2.

Using the COLLECT command

Use the COLLECT command to display the Collect Report Data panel, where you can collect specific Db2 instrumentation data and direct this data to a data set.

The command syntax is:

►► COLLECT ◀◀

To issue the COLLECT command, type COLLECT on the command line and press Enter. COLLECT can be truncated to a minimum of COL.

For more information about collecting report data, see the [Reporting User's Guide](#).

Using the OPTIONS command

Use OPTIONS to display the Session Options window, where you can set several options controlling the environment of your Interactive Report Facility (IRF) session.

The command syntax is:

►► OPTIONS ◀◀

Figure 16. Syntax of the OPTIONS command

To issue the OPTIONS command, type OPTIONS on any command line and press Enter. OPTIONS can be truncated to a minimum of OPT.

Correlation ID translation

The correlation ID is a Db2 field that identifies the task executed by Db2.

The correlation ID contains:

Batch jobs

Jobname

TSO applications

Original authorization ID (the logon user ID)

Applications using the Db2 call attachment facility

Original authorization ID (the logon user ID)

CICS® transactions

Connection type, thread type, thread number, and the transaction ID

IMS applications

PST number and PSBNAME of the application

RRS applications

The character string provided by the application during signon

Particularly for CICS and IMS it is useful to break the correlation ID into several parts, so that you can easily distinguish the transaction ID (for CICS threads) from the PSBNAME (for IMS threads).

The default translation

OMEGAMON XE for Db2 PE breaks the correlation ID into parts by translating the correlation ID into two separate identifiers, the *correlation name* and the *correlation number*. Unless it was changed in your installation, this translation is based on the connection type of the thread.

Table 3. The 12-Byte Correlation ID field and the default translation

Connection Type	1	2	3	4	5	6	7	8	9	10	11	12
Batch	Correlation name: job name								Correlation number: blank			
TSO, Db2 call attach	Correlation name: original authorization ID								Correlation number: blank			
CICS	Correlation number: pool thread				Correlation name: transaction ID							
IMS	Correlation number: application PSBNAME				Correlation name: application PST							
RRS	Correlation name: the first 8 characters of the correlation ID provided by the application during signon								Correlation number: the remaining 4 characters			

Changing the default translation

You can override this default translation by using option 8 (Maintain parameter data sets) from the Online Monitor Main Menu. The correlation translation information is kept in the member CORRDATA of the DPMPARMS data set.

Each record in the CORRDATA member specifies the translation that is to be used for a specific connection ID. The connection ID is used here, not the connection type.

The translation is expressed as:

- Offset where the correlation name starts
- Length of the correlation name
- Offset where the correlation number starts
- Length of the correlation number

If OMEGAMON XE for Db2 PE does not find the connection ID for a given thread in the CORRDATA member, the default translation is used.

To activate the tailored correlation translation, issue the OPTIONS command and specify the DPMPARMS data set in the Session Options window.

How large and missing values are displayed

Values shown in panels are either total values or average values.

If there is insufficient space to display a value in a field, a rounded value is shown followed by one of the following letters to indicate magnitude:

- K**
thousand (kilo - 10³)
- M**
million (mega - 10⁶)
- G**
billion (giga - 10⁹)
- TT**
trillion (tera - 10¹²)

The letter is displayed directly after the number, without blank spaces. There can, however, be decimal places, as in the following examples:

- Valid conversions of 12 345 include 12K, 12 . 35K, and 12 . 3K.
- Valid conversions of 1 234 567 include 1M, 1 . 2346M, and 1235K.

If a counter value or specific information in reports, in windows, or in panels is not shown, the following notation is used to indicate the reason:

N/A

Not applicable is shown if Db2 never produces a counter value in a specific context. Examples are:

- A counter is not available in one Db2 version.
- Counters are mutually exclusive.

N/C

Not calculated is shown for a derived field where the value cannot be calculated or is useless. Examples are:

- A divide by zero (percentages, ratios).
- Suppression of negative elapsed time values.
- Required counter values for calculation marked as N/A or N/P.
- Insufficient data or small counter values to allow significant statements (meaningless or misleading averages).

N/P

Not present is shown for a field where Db2 can present values, but does not in this instance. Examples are:

- When counter values are not generated because of operational conditions (a trace class is not active).
- An application does not provide a value because it is optional.

Elapsed time formats

This section shows the different time formats in which time values are presented.

- *dd hh:mm:ss.fffffff*, where:

dd

represents days

hh

represents hours

mm

represents minutes

ss

represents seconds

fffffff

represents the fractions of a second up to 8 decimal places.

For example, a time value of 1:30:25.10 represents 1 hour, 30 minutes, and 25.1 seconds.

Some of the reports that use this format might not report days (*dd*) or hours (*hh*).

- *sssssss.fffffff*, where:

sssssss

represents seconds

fffffff

represents the fractions of a second up to 8 decimal places.

The actual number of decimal places varies from one field to another.

Some time fields can be rounded. If there is insufficient space to print a time value, the time is rounded by removing decimal places as required. For elapsed times, a rounded value is printed.

Date formats

The date format for the Online Monitor is taken from your ISPF environment, and is configured during ISPF installation.

Displaying long names and values in scrollable fields

Certain identifiers, such as authorization IDs and program and collection names, can be up to 128 characters long. In general, if an identifier or any applicable field value is too long for the space available in a panel, the Online Monitor displays the information in a so-called scrollable field. To view the non-visible section of a scrollable field, you can place the cursor on the field and use an assigned function key to scroll through the information.

Figure 17 on page 23 shows a fictitious example of a panel with possible variations of scrollable fields. Relevant parts of the panel are in italics. The string *abcdefghijklmnopqrstuvwxyz* represents a hypothetical field value that is too long to fit into the available space (of whatever field).

- Variation 1 shows that the string is left-aligned and truncated at the right side (*uvwxyz* is not shown). A plus sign (+) follows the string, which indicates that more of the field's content is available on the right side.
- Variation 2 shows that the string is right-aligned and truncated at the left side (*abcdef* is not shown). A minus sign (-) follows the string, which indicates that more of the field's content is available on the left side.
- Variation 3 shows that the string is centered and truncated at the left and right sides (*abc* and *xyz* are not shown). A plus sign and a minus sign (-+) follow the string, which indicates that more of the field's content is available on both sides.

```

DGOMTWPK                               Current Package

                                     More:  +
Location . . . . . : PM01D711
Collection ID . . . . . : abcdefghijklmnopqrst +
Program name . . . . . : ghijklmnopqrstuvwxyz -
Consistency token . . . . . : defghijklmnopqrstuvw -+
----- QPACPKID+0 -----
| ISPEXPND                               Line 1 of 1 |
| abcdefghijklmnopqrstuvwxyz              |
|                                         |
| Command ==>                               Scroll ==> CSR |
| F1=Help   F2=Split   F3=Exit   F5=Rfind   F6=Rchange   F7=Up   |
| F8=Down   F9=Swap    F10=Left  F11=Right  F12=Cancel  |
-----
F7=Up      F8=Down    F9=Swap    F12=Cancel  F14=Purge
F16=Look   F17=Collect F21=Expand F22=Left   F23=Right

```

Figure 17. Fictitious panel with scrollable field variations

The plus and minus signs next to fields act as *scroll indicators*.

- If shown, they indicate that the content of a field is shown in part. No scroll indicator is shown if the complete field content can be presented.
- Whether more of a field's content is available on the left, on the right, or on both sides. Minus (-) associates the left side, plus (+) associates the right side.

Initially, all field values are shown left-aligned, which means that only the plus sign is shown. The minus sign is shown after you scrolled through a field by means of the function keys described next.

To view non-visible sections of an appropriate field, you need to position the cursor on the field and use the following function keys (the default function key settings are assumed).

- F21 (Expand) shows the field's content in a separate window, which is overlaid on the current panel. If the content exceeds the available width of this window, it continues on the next line. Pressing F3 (Exit) or F12 (Cancel) closes the window.
- F22 (Left) moves the begin of the shown field content toward the start of the actual content. The increment is the length of the available space, until the shown field content is left-aligned in the available space.
- F23 (Right) moves the end of the shown field content toward the end of the actual content. The increment is the length of the available space, until the shown field content is right-aligned in the available space.

These keys can be used in any meaningful order, provided the cursor is positioned on a scrollable field. Otherwise, pressing a key has no effect.

The mechanism described so far is applicable to *input fields* and *output fields*. When you type information in a field, you can use the same function keys to position the content of a field. However, a subtle distinction should be noted: In output fields potentially existing trailing space characters are treated as nonexistent. This means, you cannot accidentally scroll to a non-visible section of the field content. In input fields trailing space characters are considered valid. This means, when you scroll through an input field with a long sequence of space characters, the field might appear empty but in fact is not.

Finally, you can get help about the use of scrollable fields by positioning the cursor on the scroll indicator area (reserved for the -+ indicators) and pressing F1 (Help).

Chapter 3. Monitoring and tuning

This section describes how to monitor a Db2 subsystem, determine performance problems by using batch reports and the Online Monitor functions of OMEGAMON XE for Db2 PE and how to and tuning tasks with the ISPF Online Monitor. Such tasks include viewing past data and statistics, monitoring exceptions and thread activities, explaining SQL statements, and evaluating Db2 system parameters.

You can use OMEGAMON XE for Db2 PE for continuous or periodic monitoring of a Db2 subsystem and for determining specific performance problems in Db2. OMEGAMON XE for Db2 PE can help you in:

- Determining how an application will perform or is performing over a period of time
- Indicating where there are tuning opportunities in your system
- Distinguishing among subsystem and application problems
- Monitoring an application in a detailed manner so you can identify problem areas
- Analyzing constraints acting on an application
- Determining the performance effects of any adjustments made within the Db2 subsystem
- Determining whether performance objectives are being met

OMEGAMON XE for Db2 PE offers different ways to monitor your subsystem depending on whether you want to see current or past activity. Use the Online Monitor to monitor an active subsystem as well as to view events that happened in the recent past. Use the Batch reports to examine performance problems in the more distant past and trends over a period of time.

The amount of data generated for monitoring a Db2 subsystem is vast, so limiting the amount of data to show only potential problem areas is essential. OMEGAMON XE for Db2 PE offers several ways of reducing the amount of data that needs to be examined, the most important is exception processing. Exception processing makes it easy for you to focus on possible performance problems by highlighting data that is outside defined thresholds. It is available in Batch reporting and the Online Monitor.

A good approach is to monitor an active Db2 subsystem using Online Monitor exception processing (you do not need to be logged on to have exception processing running) and to regularly generate Statistics and Accounting exception reports. Online Monitor exception processing alerts you to performance problems as soon as they occur, and the Accounting and Statistics reports give you a detailed picture of application and system performance over a period of time.

Deadlock and timeout participant details are available online through exception event processing. Consider generating deadlock and timeout traces regularly, because in this way information is available to help you investigate any locking problems in detail. There is no significant performance overhead on the Db2 side in collecting the data for these reports.

The best way to investigate performance trends is by producing Accounting and Statistics reports that are ordered by interval.

To detect problems as they occur, use the Online Monitor periodic exception processing. When you detect poor thread performance, you can examine the comprehensive performance data that is shown in Thread and Statistics panels. If you assume the problem is caused by SQL, you can analyze the access path using the online explain function.

If the problem occurred in the recent past, you can use the Online Monitor HISTORY command to view the events surrounding the problem without having to re-create it.

If the panels do not provide enough information to solve the problem, you can use the Online Monitor to collect instrumentation data for batch reports. You can specify the data collection to be triggered by exception thresholds; in this way you can minimize the time high-volume and high-cost traces are active and ensure that the data needed is collected at the right time.

OMEGAMON XE for Db2 PE provides a comprehensive set of reports with different levels of detail and for different areas of performance. This represents a top-down approach to problem determination: the most

generic reports indicate the problem area and, if necessary, more details can be shown to narrow down the cause of the problem.

Changed access path to the ISPF Online Monitor

When you start IBM Tivoli OMEGAMON XE for Db2 Performance Expert on z/OS from ISPF (Start EXEC FPEJINIT), the main menu is displayed.

```
FPEFMENU      IBM OMEGAMON for DB2 Performance Expert on z/OS

Select one of the following.

__  1. Create and execute reporting commands
    2. View online DB2 activity - Classic Interface
    3. View online DB2 activity - PE ISPF OLM
    4. Maintain parameter data sets
    5. Customize report and trace layouts
    6. Exception profiling

Command ==> _____
F1=Help  F2=Split  F3=Exit  F9=Swap  F12=Cancel
```

Figure 18. Main menu

This menu provides access to the OMEGAMON XE for Db2 PE functions and to the ISPF Online Monitor (option 3).

Note: The OMEGAMON XE for Db2 PE options shown on this menu (all, except option 3) are described in detail in [Monitoring Performance from the OMEGAMON Classic Interface](#).

Nevertheless, for the time being, option 3 on the OMEGAMON XE for Db2 PE main menu invokes the ISPF Online Monitor, which was part of the predecessor products IBM Db2 Performance Expert for z/OS and IBM Db2 Performance Monitor for z/OS. The following topics introduce the options that are available for the ISPF Online Monitor.

Performance data generation and online monitoring

Db2 generates trace data about its own performance and events in Db2 subsystems. However, Db2 does not provide any reporting facilities for analyzing this data. The Online Monitor provides you with the capability to view an active Db2 subsystem and identify performance problems online.

The Online Monitor displays subsystem-wide performance information, such as processor times, buffer pool usage, locking, log, and I/O activity. For an individual thread, the Online Monitor displays information such as the elapsed time, the time spent in Db2, the time it was suspended, the read and write activity involved, the locks obtained, and the SQL statements executed.

The Online Monitor displays subsystem-wide Db2 performance information in a comprehensive form that is easy to understand and analyze. You can use the Online Monitor to:

- Determine total Db2 system performance and efficiency
- Measure an application's performance and resource use
- Evaluate an application's effect on other applications and the system
- Analyze and improve SQL statements
- Identify potential problems
- Determine tuning requirements for Db2.

When changes are made to an application or to the Db2 subsystem, the Online Monitor can help you determine the effects. This is very important for determining whether the changes increased or decreased performance.

When Db2 performance is not satisfactory, the Online Monitor can help you identify areas where tuning is required to optimize the performance of Db2. The Online Monitor can log Db2 activities and events and provide this information for later viewing to assist you in determining the cause of potential problems.

For a long-term view of Db2 performance, your needs are best served by the batch reporting capabilities.

The Db2 operating environment

The performance of a Db2 transaction or query is dependent not only on the performance of the Db2 subsystem, but also on the performance of the transaction manager, such as CICS or IMS, and the MVS system itself. Therefore the environment in which the Db2 subsystem is operating should be tuned before Db2 is tuned.

For example, if the MVS system is overloaded, tuning a Db2 subsystem is unlikely to improve Db2 system performance. Db2 performance can only be improved by reducing or balancing the load of the MVS system.

Specialized tools are available to monitor the different system components:

- CICSplex System Manager for CICS
- IMS/VS DC Monitor or IMSPARS for IMS
- RMF for MVS

The relationship between the different systems and performance tools is complex, however, it is not within the scope of this documentation. For more information, see [*IBM Db2 for z/OS in the IBM Knowledge Center*](#). It is assumed that the environment in which the Db2 subsystem is operating is well tuned.

Performance objectives and exception processing

Before you can start monitoring the system, define your performance objectives on the basis of the business needs, the workload for the system, and the resources available. Typically, the objectives would include acceptable response times, average throughput, and system availability.

These objectives are usually formalized in service-level agreements between the users and the data processing groups in an organization. The agreements can include expectations of query response times and transaction throughput.

You can monitor how well these objectives are being met.

The most efficient way to do this is to set limits, exception thresholds, for key fields that reflect your performance objectives using exception processing.

Exception profiling can assist you in establishing exception thresholds. This facility sets exception thresholds automatically based on your application configuration. For reports, the Accounting TOP subcommand option is also useful in determining Accounting exception thresholds.

For example, you can monitor response times by setting exception thresholds for class 1 and class 2 elapsed times to reflect the acceptable response times for your environment. Class 1 elapsed time shows the thread time (from thread creation to thread termination) and class 2 time shows the time Db2 spent processing SQL statements.

Monitoring performance

The key to effective performance monitoring is in identifying unusual situations and thereby limiting the amount of data that needs to be examined. In addition to exception processing, OMEGAMON XE for Db2 PE offers several other ways of filtering the data and highlighting potential problems.

The following options are available in Batch reporting:

- Filtering data by date and time (FROM and TO subcommand options)
- Filtering data by identifiers such as user ID (INCLUDE and EXCLUDE subcommand options)
- Filtering data by resource usage (TOP subcommand option)

- Ordering data on reports by interval (INTERVAL subcommand option)
- Summarizing and sorting data on SQL reports
- Tailoring report layouts for your own needs. The User-Tailored Reporting feature (UTR) and its use is described in detail in the [Reporting User's Guide](#).

The following options are available in the Online Monitor:

- Qualify and sort functions
- History data collection with qualifications

Monitoring using reports

You can filter the data shown in reports by using the INCLUDE and EXCLUDE subcommands to show, for example, information only for certain plans, authorization IDs, or locations. You can use the FROM and TO subcommands to filter data within specified times.

Another way to limit the data that needs to be examined is to use the TOP subcommand option to obtain a high water mark type of reporting on resource usage. The TOP lists, printed at the end of an Accounting report or trace, can identify the threads or users that have required the most use of the resources specified in the TOP subcommand option. Alternatively, you can use the TOP subcommand option with the ONLY keyword to filter entries based on resource usage and produce a report that shows only entries with the highest resource usage.

You can summarize data for certain periods by ordering your Accounting and Statistics reports by interval. For example, you can summarize data for the peak periods during the day.

If you produce SQL Activity reports and traces, potential problems can be highlighted by sorting and summarizing the information within the report and trace entries by several criteria. For example, a problem cursor can be identified by summarizing SQL activity by cursor and ordering the cursors by TCB times. The sorted entries provide an easy way to identify SQL statements that might be causing performance problems.

You can tailor your own report layouts and trace layouts with the User-Tailored Reporting feature (UTR). Use UTR to control the volume, contents, and layout of your traces and reports. The User-Tailored Reporting feature (UTR) and its use is described in detail in the [Reporting User's Guide](#).

Monitoring using the ISPF Online Monitor

The ISPF Online Monitor qualify and sort functions can help you limit and prioritize the threads listed in the Thread Summary panel.

Use the qualify function to filter threads by OMEGAMON XE for Db2 PE identifiers, thread status, and thread type, and to effectively reduce the amount of data that needs to be examined. For example, to view only the active threads in lock wait status, qualify the threads by selecting the 1 field on the Db2 Thread Qualification Parameters window.

Use the sort function to specify the order in which the threads are listed. For example, to view the threads that are spending the most time within Db2, you can sort the threads by class 2 time in descending order. Threads in exception status are automatically sorted to the top of the list.

Observing performance trends

You can use reports and graphs to summarize data over periods of several days, weeks, or months to observe trends in performance. Pay special attention to peak periods of activity, for new applications and for the system as a whole. During peak periods, constraints and response-time problems are most evident.

Some trends to look for are:

- Increases in response times, number of I/Os, resource contention, and processor usage
- Changing workload patterns over a period

- Changes in the transaction distribution and frequency
- Changes in the SQL activity pattern

Determining performance problems

When you find that there are performance problems when you are monitoring the system, you can use several panels and reports to investigate the cause of the problems.

Problems detected in periodic exception processing

If you use periodic exception processing in the Online Monitor and you are notified about a problem, examine the information in the Thread Activity panels or Statistics panels, depending on the type of problem.

- For system related problems, examine the Statistics panel and the Db2 System Parameters panel.
- For application related problems, examine the Thread Activity panels.

To view the past events surrounding the problem online, you can use the HISTORY command. The amount of available historical data is determined by installation-defined options. Note, however, that the batch reports are more comprehensive than the Online Monitor panels. Therefore, if the panels do not provide enough information to solve a problem, the Online Monitor Collect Report Data function should be used to gather information in a data set for input to the batch reports.

Problems detected in exception event processing

If you detect a problem using the online exception event processing and the Online Monitor panels do not provide sufficient information to determine the cause, collect the appropriate trace data to produce Locking reports, I/O Activity reports, Audit reports, or Record Trace reports. This section describes how to proceed with specific exception events.

Deadlock or Timeout

If deadlocks or timeouts occur too often, generate a Lockout report to see which applications and objects are affected. Having identified the objects and applications causing the deadlocks or timeouts, use EXPLAIN to understand the locking behavior of the SQL statements or consider reorganizing the database.

EDM Pool Full

First check online or batch statistics to obtain more information about the EDM Pool situation. More details are provided in the I/O Activity EDM Pool report.

Authorization Failure

If authorization failures occur too often, generate an Audit authorization failure report for details.

Thread Commit Indoubt

Run a Record trace on the Statistics Class 4 IFCIDs to see details of communication problems. These are likely to be either VTAM® or Db2 internal problems.

Coupling Facility Rebuild

Use the COLLECT command to automatically start tracing IFCID 268 (CF rebuild end) when a coupling facility rebuild starts, and run a Record trace for this IFCID. You can get more details about coupling facility behavior from RMF reports.

Problems detected in exception reports

If you use an Accounting exception report to monitor your system, produce this report using the TOP or the INTERVAL subcommand option so that you can immediately focus on potential problem areas.

If you use an Statistics exception report to monitor your system, produce this report using the INTERVAL subcommand option so that you can immediately focus on potential problem areas

Sometimes, however, you require more detailed reports to determine the exact cause of a problem.

System problems

If exception processing indicates problems in system-wide resource usage and a Statistics trace does not clarify the reason for the problem, but points to EDM pool or logging activity, consider running I/O Activity reports. Or, if the Statistics trace indicates a problem with binds, generate Utility Activity reports. If the number of deadlocks is high, run Locking reports. If none of these report sets offer adequate information to determine the cause of the problem, you can run a Record trace to format the individual instrumentation records.

Application problems

If exception processing indicates an application-related problem, which is typically indicated as an elapsed time problem for an application or a user, use Explain reports to determine the access path of the suspected plan. In addition, if necessary, generate Accounting traces by using the TOP subcommand option.

- If the Explain reports and the Accounting traces do not identify the reason for poor SQL performance, use SQL Activity reports for detailed information about the specific statement, such as scans or I/O per page set or sort specifics.
- If the Accounting traces indicate a locking problem, run Locking reports.
- If the problem seems to be with binds or Db2 utilities, run Utility Activity reports.

As with system-related problem determination, you can run a Record trace if none of these report sets provide adequate information.

Viewing past data

You can recall and view statistics, thread activity, and system parameters data previously collected by the data collector. The data is gathered at installation-defined intervals.

You can view past data by issuing the HISTORY command or pressing F6 (History) in any panel that can display past data.

When viewing past data, the word HISTORY is displayed on the line following the heading of the current panel.

```
DGOMTPSM 11:57          Thread Detail          PM01DLOC DSN1 V10
                                GROUP001 MEMBER01 HISTORY 05/30/08 11:45:00
For details, place any character next to heading, then press Enter.
```

Figure 19. Thread Detail panel showing history active

The date and time following the word HISTORY indicate when the data being displayed was collected.

Note: You can view past data only if the data collector is installed at your site.

Your installation can choose to collect data at the following levels:

- Thread Summary
- Thread Detail
- Thread Detail with locking information
- Thread Detail with SQL statement
- Thread Detail with locking information and SQL statement
- Statistics
- System Parameters

Historical data is kept in either a VSAM data set or data space. The data is gathered by the data collector. When the data set or data space is full, the data is written to the beginning again, writing over the earliest data gathered.

The availability of the data is limited by the collection rate, the size of the data space or data set used, the amount of historical data to be maintained, and the thread history qualification definitions (all of these are defined in the data collector startup parameters).

The data collector parameters can also be modified by the administrator user.

The syntax of the HISTORY command is:

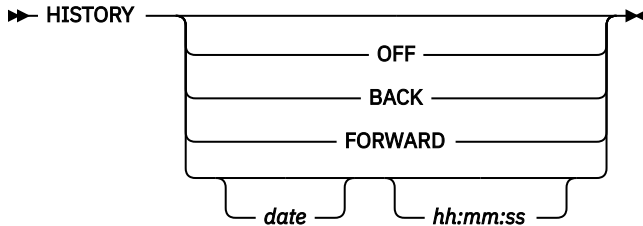

Figure 20. Syntax of the HISTORY command

The HISTORY command accepts the following parameters:

OFF

Returns the display to the current time.

BACK

Displays data for the previous interval. If no more data is available, data from the earliest available interval is displayed.

FORWARD

Displays information for the next available interval. If no data is available, data from the current time is displayed and processing continues as if HISTORY is OFF.

date

The date of the required information. If no date is specified, today’s date is assumed.

hh:mm:ss

The time of the required information. If no time is specified, the default is the time of the earliest available history record for the specified date. The seconds do not need to be specified.

Note: HISTORY can be truncated to a minimum of HIS.

If no data is available for the specified date and time, the next available record is displayed.

When a panel is refreshed while viewing past data, the panel is updated with data from the next stored record, just as if you had entered HISTORY FORWARD on the command line.

If no parameters are specified, the History window is displayed.

```

DGOMHWHY                History
                          05/09/08  14:03

Date . . . . . 03/16/08
Time . . . . . 14:03:24

F1=Help   F2=Split   F9=Swap
F12=Cancel
  
```

Figure 21. History window

The current system date and time are the defaults for the History window.

Note: When monitoring with HISTORY OFF, it is possible to view data that cannot be viewed by using the HISTORY command. This occurs when the “current moment” does not coincide with the history collection interval. For example, when the history interval is 10 minutes in length and data is collected at 8:30 and 8:40, the data retrieved at 8:32 from DB2 is not subsequently retrievable using the HISTORY command.

A sample JCL is provided in library RK02SAMP (DG0MMJCL) that can be used to unload history VSAM data sets created by the data collector. After unloading, you can use the data as input to the batch Record trace function for problem determination. The sample JCL might need to be modified.

Exception processing

Exception processing is the most effective way of identifying performance problems. The first step in monitoring your Db2 system should always be to start thread and statistics exception processing.

Use Online Monitor exception processing to identify Db2 thread and statistics fields with values outside defined thresholds. This allows better management of service levels by identifying problems in the Db2 subsystem and threads causing performance problems.

By using display exception processing and periodic exception processing, you can monitor and identify:

- Threads that might be experiencing problems
- Subsystem-wide Db2 conditions that might be causing performance problems

By using exception event processing, you can monitor the following events:

- Deadlock
- Timeout
- EDM pool full
- Authorization failure
- Thread commit indoubt
- Coupling Facility (CF) rebuild/alter start
- CF rebuild/alter end
- Global trace started

The threshold values for thread activity and statistics fields are specified in the Exception Threshold data set. When exceptions are detected during your monitoring session, you are notified so that appropriate action can be taken. In addition, you can activate a user exit that can automatically trigger any immediate reaction, for example, issue an alert to NetView.

You can view information about any of the exceptions using the Online Monitor **LOOK** command.

With exception processing, you can create the following two data sets for later analysis:

- The Exception Log data set (to print a list of exceptions or to load exception data into Db2)
- The Exception DPMOUT data set (records that had exceptions)

Exception processing modes

This section describes the three basic types of exception processing available: display exception processing, periodic exception processing, and exception event processing.

Display exception processing

Use display exception processing to monitor the occurrence of a specific exception. This exception processing mode operates in the foreground of Online Monitor processing. With display exception processing you can view thread activity exceptions, and statistics exceptions in interval or delta processing mode. See [“Statistics processing modes”](#) on page 90 for an explanation of delta and interval processing.

With display exception checking, fields shown in the current panel are checked whenever the display is refreshed with new or historical data. Fields with exception conditions are shown in reverse video, and the color of the field indicates the level of the exception. *Warning* level exceptions are highlighted in yellow, while *Problem* level exceptions are highlighted in red. These colors can differ if you have changed your ISPF default colors. Selection fields in the detail panels are also shown in reverse video if any of their

lower level windows contain fields in exception status. The exception notifications are stored and can be examined using the LOOK command.

Periodic exception processing

Use periodic exception processing to periodically monitor thread activity fields and statistics fields for exception conditions. This processing mode runs in the background of Online Monitor processing.

With periodic exception processing, data is tested for exception whenever the interval that you specified has elapsed (whether or not you are viewing the relevant data). If any *Problem* level exceptions are detected, the Exception Notification window is displayed. If only *Warning* level exceptions are detected, a message is displayed to notify that a periodic exception has occurred. This window is overlaid on the current panel and shows the number of periodic exceptions detected during the interval. The exception notifications are stored and can be examined using the LOOK command.

If the data collector is active, periodic exception processing can continue when you exit the Online Monitor. When you use the Online Monitor the next time, any periodic exceptions that were detected while you were not logged on are displayed. Periodic exception processing is not terminated until you stop it or until the data collector itself is terminated. If the data collector is not active, periodic exception processing terminates when you exit the Online Monitor.

Exception event processing

Use exception event processing to monitor the Db2 subsystem for the occurrence of particular events. This processing mode runs in the background of Online Monitor processing. The following events can be monitored:

- Deadlock
- Timeout
- EDM pool full
- Authorization failure
- Thread commit indoubt
- CF rebuild/alter start
- CF rebuild/alter end
- Global trace started
- Data set extension
- Unit of recovery problem
- Log space shortage

The events must be specified with the EXCEPTIONEVENT data collector parameter or in the Data Collector Parameters window before exception event processing can be activated from the Exception Processor panel. For more information, see the [*IBM Db2 for z/OS in the IBM Knowledge Center*](#).

When an exception event is detected, the Exception Notification window is displayed to notify you that an exception event has occurred. Exception event notifications are stored and can be examined using the LOOK command.

Past data and exceptions

Display exception processing operates with past data just as if the data had been retrieved directly from Db2. Exceptions are shown in reverse video and logged as normal.

Periodic exception processing and exception event processing do not report on past data. They report on current data, whether or not past data is currently being displayed.

Exception Notification window

The Exception Notification window is displayed whenever periodic exception or exception event processing is active and either a problem level exception or an event exception is detected. This window is overlaid on the current panel and shows the number of periodic *problem* and *warning* level exceptions, and the number of exception events since the last exception notification or since exception processing was started.

If exception event processing is active, the Exception Notification window is shown, as in the following figure.

```
DGOMEPE1                Exception Notification
Time . . : 04/14/08 12:42:32

Periodic Exceptions
Problem . . . . . : 0
Warning . . . . . : 0

Exception Events
Deadlock . . . . . : 0
Timeout . . . . . : 0
EDM Pool Full . . . . . : 0
Authorization Failure . . . . . : 1
Thread Commit Indoubt . . . . . : 0
CF rebuild/alter start . . . . . : 0
CF rebuild/alter end . . . . . : 0
Global trace started . . . . . : 0
Data set extension . . . . . : 0
Unit of Recovery problem . . . . . : 0
Log space shortage . . . . . : 0

F1=Help    F2=Split    F9=Swap
F12=Cancel
```

Figure 22. Exception Notification window (exception event processing active)

If exception event processing is not active, the Exception Notification window is shown, as in the following figure.

```
DGOMEPEX                Exception Notification
Time . . : 04/04/08 11:53:26

Periodic Exceptions
Problem : 1
Warning : 2

F1=Help    F2=Split    F9=Swap
F12=Cancel
```

Figure 23. Exception Notification window (exception event processing inactive)

To exit the Exception Notification window and return to the panel you were viewing, press Enter or F12 (Cancel).

The Periodic Exceptions section of this window shows the number of Problem and Warning level periodic exceptions since the last time you were notified of an exception.

The Exception Events section of this window shows the number of exception events that occurred for various events since the last time you were notified of an exception. This field categorizes the seven different classes of exception events that can occur.

Difference between batch and Online Monitor exception processing

The fundamental difference between batch and Online Monitor exception processing is that the Online Monitor shows an active view of Db2 subsystem activity (active threads), whereas batch exception processing shows activity that has been completed (threads that have ended). Therefore, the values

shown by the Online Monitor and Batch are unlikely to match. For example, a thread shown to be in exception status in a Batch Accounting trace is not necessarily in exception status in the Online Monitor.

How to define exception threshold values

This information shows where exception thresholds are defined.

This information has been consolidated in the [Reporting User's Guide](#) for consistency reasons.

How to start exception processing

Exception processing is started from the Exception Processor panel. All exception processing functions are activated from this panel.

Figure 24 on page 36 shows the Exception Processor panel.

Alternatively, exception processing can automatically be started when the OMEGAMON Collector is started.

Starting exception processing when the OMEGAMON Collector is started

When the OMEGAMON Collector is started, its startup parameters determine whether exception events are to be processed. Dependent on which exception events are specified, the appropriate traces are started. If an Exception Threshold data set with exception criteria is already available, it can be specified in the OMEGAMON Collector startup parameters. By this means, exception processing automatically starts with predefined exception thresholds whenever the OMEGAMON Collector is started.

For more information about the Exception Threshold data set, a sample data set provided with the product, its data set attributes, and how its content can be modified, see the [Reporting User's Guide](#).

For more information about OMEGAMON Collector startup parameters, see the topic about configuring OMEGAMON Collector for exception processing in [Monitoring Performance from the OMEGAMON Classic Interface](#). The **EXCEPTIONEVENT** startup parameter determines the events, and the **AUTOEXCPTHNAME** startup parameter specifies the name of the Exception Threshold data set that is to be used at startup.

If this means of starting exception processing is used, and if the content of the Exception Threshold data set is modified while the OMEGAMON Collector is running, remember to refresh the environment if you want the new exception criteria to be recognized.

Refer to [“How to restart exception processing \(REINIT command\)”](#) on page 38 for more details.

Starting exception processing from the Exception Processor panel

Use the Exception Processor panel to activate and deactivate various exception processes by selecting exceptions under Activate/Deactivate Exception Processing.

To display this panel, select option 5 (Control Exception Processing) from the Online Monitor Main Menu.

```

DGOMEPO2                Exception Processor                PM01DLOC DSN1 V10

For any field enter any character to activate

Activate/Deactivate Exception Processing
- Display thread summary
- Display thread detail
- Display statistics detail > Periodic
- Exception event notification

Options
Periodic units . . . . . 2      1=Seconds
                                   2=Minutes
Periodic interval . . . . . 10  1-7200 Seconds
                                   1-120 Minutes

> Disable auto-display for problem exceptions
> Sound alarm for exception warnings
- Log file data set output needed
- DPMOUT data set output needed

Exception threshold data set
Name . . . . . -----

Command ==> -----
F1=Help      F2=Split    F3=Exit     F7=Up       F8=Down     F9=Swap
F12=Cancel   F16=Look    F17=Collect

```

Figure 24. Exception Processor panel

Use the 1 field to specify whether the 1 field value is in seconds or minutes. This field is only required for periodic exception processing.

The 1 field specifies how often Db2 instrumentation data is gathered, examined for exceptions, and reported if an exception condition occurs. All periodic exception messages are gathered periodically as specified by this field, and reported when the display is refreshed. After the elapsed period, if any periodic exceptions have occurred, the Exception Notification window is displayed and shows the number of warning and problem exceptions. This field is only required for periodic exception processing.

You can request a Log File data set or DPMOUT data set to be written by selecting Log file data set output needed or DPMOUT data set output needed from the Exception Processor panel, respectively. When you request a log or DPMOUT file, the Exception Output Data Sets window is displayed. See “Exception Output Data Sets window” on page 37 for details.

Previously selected fields are indicated by a greater than symbol (>).

The Exception threshold data set field contains the name of the Exception Threshold data set used as input to the exception processor. The data set is built using the Exception Threshold Field Details panel. The Online Monitor exception processor uses the information in this data set to test fields for exception conditions.

Note: A valid Exception Threshold data set needs to be specified in the Exception Processor panel before activating display exception, periodic exception, or exception event processing.

Exception processing user exit

OMEGAMON XE for Db2 PE supports a user exit to enhance the exception processing capabilities. This exit can handle periodic exceptions and event exceptions. Therefore, you can start the exception user exit for periodic processing, event processing, or both, depending on which kind of exception processing you have activated in the Exception Processor panel.

You can activate the user exit together with periodic exception processing, event exception processing, or both. But you can also activate it when periodic exception processing, event exception processing, or both are already active.

To activate the user exit, type any character in the User Exit field. To deactivate the user exit, enter a blank in this field. The User Exit field is displayed only if the data collector is active.

Several users can invoke periodic exception processing or event exception processing simultaneously using different threshold data sets. The users can start or stop this user exit independently. The user exit

routine can check for the user ID, the exception field name, the field value, or other characteristic items to select individual paths of processing.

OMEGAMON XE for Db2 PE provides a sample of the exception processing exit, called DGOMUPXT, which issues a message to the operator. The message text varies depending on whether the situation is an event exception or a periodic exception. For a description of the different formats of this message, see message number DGOV0100I in *Messages*.

You can modify DGOMUPXT according to your needs, for example, to examine the type of exception and perform any action necessary to handle the situation.

For more information, see *IBM Db2 for z/OS in the IBM Knowledge Center*.

Exception Output Data Sets window

The Exception Output Data Sets window is displayed whenever you have requested a Log File or DPMOUT data set in the Exception Processor panel.

```
DGOMEPO3          Exception Output Data Sets
Specify the data set(s) to be used, and press Enter

Display log file data set
Name . . . . . -----
Disposition . . 1 1=append 2=overwrite 3=new

Display DPMOUT data set
Name . . . . . -----
Disposition . . 1 1=append 2=overwrite 3=new

Periodic log file data set
Name . . . . . -----
Disposition . . 1 1=append 2=overwrite 3=new

Periodic DPMOUT data set
Name . . . . . -----
Disposition . . 1 1=append 2=overwrite 3=new

F1=Help  F2=Split  F7=Up    F8=Down  F9=Swap  F12=Cancel
```

Figure 25. Exception Output Data Sets window

Use this window to enter the names of the Exception Log data set and DPMOUT data set you want the exception processor to write to. If the data collector is active for your current subsystem, make sure that it is authorized to write to these data sets. Different data sets are used for display exceptions and periodic exceptions.

For data sets selected in the Exception Processor panel, a valid name is required. Do not specify a name for those data sets that were not selected. Therefore, if a LOG data set was selected but not a DPMOUT data set, then you must enter a valid name for the Exception Log data set, but not for the DPMOUT data set.

You can enter the name of an output Log File data set where exception conditions are written. An entry is written to the data set for each exception condition detected by the exception processor. This data set can subsequently be used as input to the Db2 LOAD utility, or printed using the Exception Log print utility.

See [“Printing the Exception Log File data set” on page 43](#) for more information.

For the layout of the Exception Log File data set, see [“Layout of the Exception Log File output record” on page 197](#).

You can enter the name of an output DPMOUT data set where DPMOUT-formatted records that contain exception conditions are written. This data set can be used as input to a batch Record trace or Statistics trace for a more detailed analysis of exception conditions. See the *Report Reference* for information about the layout of DPMOUT-formatted records.

The Disposition fields specify how the data is to be written to the data sets. Enter 1 (append) to append the data, 2 (overwrite) to overwrite the old data, or 3 (new) to dynamically allocate a new data set.

Press Enter to initialize exception processing and to activate the selected functions. If there are any errors during this process, a panel is displayed that shows the errors.

Starting display exception processing

Display exception processing is started from the Exception Processor panel under Activate/Deactivate Exception Processing.

The Exception Processor panel is shown in see [Figure 24 on page 36](#).

Enter any character in the following fields to activate display exception processing for the appropriate panels:

- Display thread summary
- Display thread detail
- Display statistics detail

Starting periodic exception processing

Periodic exception processing is started from the Exception Processor panel under Activate/Deactivate Exception Processing.

The Exception Processor panel is shown in [Figure 24 on page 36](#).

Enter any character in the 1 field and specify the periodic exception units and interval under the Options field to activate periodic exception processing.

Starting exception event notification

Exception event notification is started from the Exception Processor panel under Activate/Deactivate Exception Processing.

The Exception Processor panel is shown in [Figure 24 on page 36](#).

Enter any character in the Exception event notification field to activate exception event notification.

The events must be specified with the EXCEPTIONEVENT data collector parameter or from the Data Collector Parameters window of the administrator user dialog before exception event processing can be activated.

How to restart exception processing (REINIT command)

If the values in the Exception Threshold data set are changed during an Online Monitor session, the exception processor needs to be restarted (reinitialized) to load and use the new values.

Exception processing *initialization* occurs when you start display or periodic exception processing using the options in the Exception Processor panel as shown in [Figure 24 on page 36](#). You can *reinitialize* exception processing by stopping and starting exception processing from the Exception Processor panel.

You can also reinitialize exception processing by using the REINIT command. The command syntax is:

➡ REINIT ↩

Figure 26. Syntax of the REINIT command

Type REINIT (or a valid abbreviation, beginning with a minimum of REI) on any command line (except on the Asynchronous Task Termination panel) as long as exception processing is active, and press Enter.

Examining exception messages (LOOK command)

This section describes how to examine exception messages issued during exception processing using the LOOK command.

Whenever an exception occurs, an exception message is written to the appropriate exception list where it can be examined using the LOOK command.

The command syntax is:

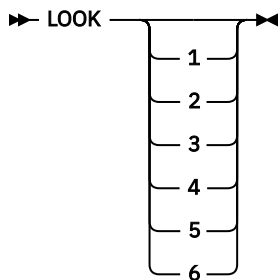

Figure 27. Syntax of the LOOK command

The LOOK parameters 1 to 6 correspond to the options on the Look Selections menu in [Figure 28 on page 39](#).

To display the Look Selections menu, type LOOK and press Enter on any command line, or press F16 (LOOK).

```
DGOMLMSP 03:35    Look Selections
Subsystem: PM01DLOC          DSN1 V10
Select one of the following displays
--  1.  Periodic Exceptions
    2.  Periodic Exceptions Messages
    3.  Display Exceptions
    4.  Authorization Failure Summary
    5.  Exception Event Summary
    6.  Exception Event Messages

Command ==>  F2=Split  F3=Exit  F6=History  F9=Swap  F12=Cancel
             F1=Help   F17=Collect
```

Figure 28. Look Selections menu

Use the Look Selections menu to reach panels that display exception messages and the status of exception processes. The list panels display the last 500 exceptions and authorization failures that occurred during your Online Monitor session. When this limit is reached, the oldest entries in the list are discarded as new entries are added. When these windows are first displayed, the bottom of the list is displayed and shows the most recent exceptions that occurred.

The following topics describe the windows that can be accessed from the Look Selections menu.

Examining the Periodic Exceptions

To display the Periodic Exceptions List window, select option 1 (Periodic Exceptions) from the Look Selections menu or type LOOK 1 and press Enter on any command line.

```

DGOMLAXP                Periodic Exceptions List                Row 499 to 500 of 500

Periodic Interval started . . . . . : 03/30/08 08:52:04.10
Last Interval . . . . . : 03/30/08 08:53:35.85

   Time      Location      Group  Subsystem  Member  Corrname
   Field     Reqloc          Primauth Planname  Connect Corrnmbr
   Descr
-----
- 08:35:36 PM01DLOC      GROUP001 N/P      MEMBER01
   N/P      N/P      N/P
SLRSUSP 100 > 0 Problem Total
TOTAL ALL SUSPENSIONS

- 13:21:28 PM01DLOC      GROUP001 N/P      MEMBER01
   N/P      N/P      N/P
ADRECETT 0.0 < 100 Problem Commit
ELAPSED TIME IN APPLICATION (CLASS 1)
***** Bottom of data *****

Command ==>
F1=Help   F2=Split   F3=Exit   F7=Up     F8=Down   F9=Swap
F12=Cancel

```

Figure 29. Periodic Exceptions List window

Use this window to view the most recent periodic exceptions that have occurred. You can use the scrolling keys F7 (Up) and F8 (Down) to browse the list.

Select any of the entries listed in this window to display either the Thread Detail panel or Db2 Statistics Detail panel as appropriate, where you can examine the field causing the exception. Pressing F3 (Exit) or F12 (Cancel) returns you to the Periodic Exceptions List window. If the selected exception was caused by a thread that is no longer active, past data is automatically retrieved if available to display the thread.

For more information about history, see “Viewing past data” on page 30.

This list is cleared if you exit the Online Monitor without an active data collector running.

Examining the Periodic Exceptions Messages

To display the Periodic Exception Messages window, select option 2 (Periodic Exceptions Messages) from the Look Selections menu or type LOOK 2 and press Enter on any command line.

```

DGOMLAMP                Periodic Exception Messages                ROW 1 TO 2 OF 2

Message
DGOM944 Periodic Exception Processor started at 03/30/08 08:52:04.100
DGOM945 Periodic Exception Processor stopped at 03/30/08 08:53:07.290
***** BOTTOM OF DATA *****

Command ==>
F1=Help   F2=Split   F3=Exit   F7=Up     F8=Down   F9=Swap
F12=Cancel

```

Figure 30. Periodic Exception Messages window

Use this window to view messages issued by the periodic exception processor. You can use the scrolling keys F7 (Up) and F8 (Down) to browse the list.

This list is cleared when you exit the Online Monitor.

Examining the Display Exceptions

To display the Display Exception List window, select option 3 (Display Exceptions) from the Look Selections menu or type LOOK 3 and press Enter on any command line.

```

DGOMLSXP                Display Exception List                Row 499 to 500 of 500

Time      Location      Group  Subsystem  Member  Corname
Field     Reqloc              Primauth Planname  Connect Corinmbr
Descr     Value              Compare  Threshold Type     By
-----
08:35:36  PM01DLLOC          GROUP001 N/P        MEMBER01
          N/P                N/P        N/P
SLRSUSP  100                >          0          Problem  Total
TOTAL ALL SUSPENSIONS

13:21:28  PM01DLLOC          GROUP001 N/P        MEMBER01
          N/P                N/P        N/P
ADRECETT 0.0                <          100       Problem  Commit
ELAPSED TIME IN APPLICATION (CLASS 1)

***** Bottom of data *****

Command ==>
  F1=Help   F2=Split   F3=Exit   F7=Up     F8=Down   F9=Swap
  F12=Cancel

```

Figure 31. Display Exception List window

Use this window to view information about the latest display exceptions that have occurred during your Online Monitor session. You can use the scrolling keys F7 (Up) and F8 (Down) to browse the list.

This list is cleared when you exit the Online Monitor.

Examining the Authorization Failure Summary

To display the Authorization Failure Summary window, select option 4 (Authorization Failure Summary) from the Look Selections menu or type LOOK 4 and press Enter on any command line.

```

DGOMLAFS                Authorization Failure Summary                ROW 1 TO 3 OF 3

Reporting Started . . . . . : 03/30/08 08:52:04
Last Interval . . . . . : 03/30/08 09:01:23

For details, place any character next to date and press Enter

  Date      Time      Authorization ID
_ 03/30/08  08:52:04  USER300
_ 03/30/08  08:52:34  USER300
_ 03/30/08  08:53:07  USER300

***** BOTTOM OF DATA *****

Command ==>
  F1=Help   F2=Split   F3=Exit   F7=Up     F8=Down   F9=Swap
  F12=Cancel

```

Figure 32. Authorization Failure Summary window

Use this window to view a list of authorization failures. You can select any item from the list to display the Authorization Failure Detail window, where the authorization failure can be examined in greater detail. You can use the scrolling keys F7 (Up) and F8 (Down) to browse the list.

Examining the Exception Event Summary

To display the Exception Event Summary window, select option 5 (Exception Event Summary) from the Look Selections menu or type LOOK 5 and press Enter on any command line.

```

DGOMLEXP                Exception Event Summary                ROW 1 TO 4 OF 4

Reporting Started . . . . . : 12/07/09 08:52:04
Last Interval . . . . . : 12/07/09 09:01:23

   Date      Time      IFCID
  _ 12/07/09 08:52:50  172 Deadlock
  _ 12/07/09 08:53:06  267 CF rebuild/alter started
  _ 12/07/09 08:54:11  090 Global trace started
  _ 12/07/09 08:54:12  359 Index split
  _ 12/07/09 08:54:13  337 Lock escalation
***** BOTTOM OF DATA *****

Command ==>
F1=Help   F2=Split  F3=Exit   F7=Up     F8=Down   F9=Swap
F12=Cancel

```

Figure 33. Exception Event Summary window

Use this window to view the most recent exception events that occurred during your Online Monitor session. You can use the scrolling keys F7 (Up) and F8 (Down) to browse the list.

Select any event listed on the Exception Event Summary window for closer examination. When an exception event is selected, one of the following windows is displayed as determined by the type of event:

- EDM Pool Full Data window
- Deadlock Data window
- Timeout Data window
- Coupling Facility (CF) Rebuild/Alter Start Event window
- CF Rebuild End Event window
- CF Alter End Event window
- Unformatted Record panel (thread commit indoubt)
- Global trace started
- Data Set Extension Data window
- Unit of Recovery Inflight or Indoubt Data window
- Active Log Space Shortage Data window

For IFCID 337 (Lock Escalation) an IFCID 359 (Index Split) exception events no details are available because the ISPF Online Monitor runs in Db2 10 toleration mode only.

Examining the Exception Event Messages

To display the Exception Event Messages window, select option 6 (Exception Event Messages) from the Look Selections menu or type LOOK 6 and press Enter on any command line.

```

DGOMLEMP                Exception Event Messages                ROW 1 TO 4 OF 4
-----
DGOM953 Exception event processor started at          03/30/08 08:52:04.100
DGOM954 Exception event processor stopped at         03/30/08 08:52:10.100
***** BOTTOM OF DATA *****

Command ==>
F1=Help      F2=Split    F3=Exit     F7=Up       F8=Down     F9=Swap
F12=Cancel

```

Figure 34. Exception Event Messages window

Use this window to view messages issued by the exception event processor. You can use the scrolling keys F7 (Up) and F8 (Down) to browse the list.

Exception processor output data sets

Exception processing output data can be written to data sets. Use these data sets for further analysis of exception conditions.

Note: Always write monitor, trace, Exception Log File, and exception DPMOUT data to separate data sets.

Exception Log File data set

You can specify a particular Exception Log File data set where information about exceptions is written. The contents of the Exception Log File data set can be either printed or loaded into a Db2 table for further investigation.

To retain log file data on the same data set across multiple Online Monitor sessions, specify APPEND for the disposition.

To dynamically allocate a new Exception Log File data set with the following attributes, specify NEW for the disposition:

```

RECFM:
  VB
LRECL:
  512
BLKSIZE:
  4 096

```

The data set contains an entry for each field found in exception status.

See [“Layout of the Exception Log File output record” on page 197](#) for the layout of the Exception Log File data set.

Printing the Exception Log File data set

You can print the contents of the Exception Log File data set using the Exception Log File print utility.

To use this utility, submit the sample member DGOMEJCL found in the RKO2SAMP library. This member is provided as an example and can be modified as required.

Performance Database

Exception data can be loaded into OMEGAMON XE for Db2 PE’s Performance Database.

You can find CREATE TABLE DDL, LOAD, CREATE VIEW statements, and sample SQL queries in the RKO2SAMP library, in the following members:

```

CREATE TABLE statement:
  DGOECFIL

```

LOAD utility control statement:

DGOELFIL

Sample CREATE VIEW statement:

DGOEVFIL

Sample SQL query:

DGOEQFIL

Exception DPMOUT data set

You can specify a particular exception DPMOUT output data set. This data set holds the Db2 instrumentation records that contain at least one field in exception status, in DPMOUT format. You can use this data set as input to a batch Record trace or Statistics trace for a more detailed analysis of exception conditions.

To retain DPMOUT data on the same data set across multiple Online Monitor sessions, specify APPEND for the disposition.

To dynamically allocate a new DPMOUT data set with the following attributes, specify NEW for the disposition:

RECFM:

VBS

LRECL:

32 756

BLKSIZE:

6 233

See the *Report Reference* for information about the layout of the DPMOUT record.

Stopping exception processing

The different types of exception processing can be stopped using the Exception Processor panel by deselecting the appropriate fields under Activate/Deactivate Exception Processing.

Figure 24 on page 36 shows the Exception Processor panel.

If an exception task is active when you exit the Online Monitor, you are notified by one of the Asynchronous Task Termination panels. You can either keep selected tasks active (if the data collector is active) and exit the Online Monitor, or return to the Online Monitor Main Menu keeping all asynchronous tasks active.

See [“Leaving the ISPF Online Monitor”](#) on page 15 for more information.

If an exception task is active when you change Db2 subsystems, you are notified by one of the Asynchronous Task Termination panels. You can either change Db2 subsystems and terminate all asynchronous tasks, or return to the previous panel keeping all asynchronous tasks active.

See [“Db2 Subsystem windows”](#) on page 8 for more information.

If you work in split screen mode and you change the subsystem in one session, periodic exceptions are terminated even if they were turned on in the other session.

Displaying thread activity

Use the Thread Activity panels to examine information about the current activity of all active threads connected to a Db2 subsystem.

Note: This function is not supported for Db2 11.

From the Thread Summary panel you can view key values for all connected threads (qualified and sorted as you require). You can select any thread listed in the Thread Summary panel to display the Thread Detail panel for further investigation of the thread.

The Thread Detail panel provides an overview of all thread information categories and some more detailed values. If you select a category, a new window opens, with all information pertaining to this category.

The following table lists all Thread Activity panels shown in this section.

<i>Table 4. List of all Thread Activity panels</i>	
Thread Activity panel name	Thread Activity panel content
Thread Summary panel	Figure 36 on page 49
Thread Detail panel	Figure 40 on page 52
Thread Identification window	Figure 41 on page 54
Requester Correlation Data window	Figure 42 on page 55
Current Package/DBRM window	Figure 43 on page 56
Thread Times window	Figure 45 on page 59
Locking (IRLM) Activity window	Figure 46 on page 60
Locked Resources window	Figure 47 on page 63
Threads Holding Resource window	Figure 48 on page 64
RID List Processing window	Figure 49 on page 64
SQL Activity window	Figure 50 on page 66
Buffer Manager Activity window	Figure 51 on page 68
Buffer Pool Detail window	Figure 52 on page 68
SQL Statement and Package window	Figure 53 on page 70
Distributed Data window	Figure 56 on page 72
Distributed Location Detail window	Figure 57 on page 73
Distributed Conversation Detail window	Figure 58 on page 74
IFI (Class 5) and Data Capture window	Figure 59 on page 74
Query Parallelism Data window	Figure 60 on page 75
Data Sharing Locking Activity window	Figure 61 on page 77
Group Buffer Pools Activity window	Figure 62 on page 78
Group Buffer Pool Detail window	Figure 63 on page 79
Stored Procedures window	Figure 64 on page 80
Db2 Thread Qual. Parameters window	Figure 74 on page 85
Db2 Thread Sort Specification window	Figure 77 on page 89

Display Thread Activity overview

The Thread Summary panel shows a summary of all connected Db2 threads qualified and sorted as defined by the QUALIFY and SORT commands.

You can select individual threads for viewing from the Thread Summary panel, the Threads Holding Resource window, or the Periodic Exceptions List panel. Selecting a thread results in all currently displayed windows being removed and the Thread Detail panel being displayed for the newly selected thread. This thread then becomes the monitored thread for further examination using the Thread Activity panels. From the Thread Detail panel, you can view specific information about the monitored thread in

greater detail. To do this, type any character in the selection field next to the corresponding headings and press Enter.

Data displayed in the current panel is refreshed whenever you press Enter *without* selecting a particular category to be displayed or executing a command.

Before you start displaying thread activity, ensure that the appropriate Db2 monitor trace classes are set on. At least monitor class 1 must be set on, but it is a good practice to also set on class 2 and class 3. If you also want to obtain class 5, 7, or 8 information, switch on the corresponding monitor trace class.

If display exception processing is active, any fields in exception status are shown in reverse video. If you are using a color terminal, fields in *warning* status are highlighted in yellow, while fields in *problem* status are highlighted in red. Furthermore, a pop-up window shows the number of display exceptions detected.

You can purge a thread currently processing in a Db2 subsystem from any Thread Activity panel using the PURGE command. You require the Db2 privilege to perform CANCEL THREAD. See [“PURGE command” on page 83](#) for more information about purging a thread.

For a Db2 thread that exploits parallelism, OMEGAMON XE for Db2 PE reports aggregated values across all parallel tasks that are created to execute SQL statements within the thread. Therefore, and because of the nature of parallel work, some counters (particularly processor and suspension fields) can show unexpected large values, which do not necessarily indicate problems. Sometimes these values are even larger than the entire wall-clock elapsed time. Besides query parallelism OMEGAMON XE for Db2 PE also reports Db2 utility parallelism. Further details are described in the following paragraph.

Accounting times

Accounting times are usually the prime indicator of a performance problem and should be the starting point for analysis.

Db2 times are classified as follows:

- Class 1 time shows the time the application spent since connecting to Db2, including time spent outside Db2.
- Class 2 elapsed time shows the time spent in Db2. It is divided into CPU time and waiting time.
- Class 3 elapsed time is divided into various waits, such as the duration of suspensions because of waits for locks and latches or waits for I/O.

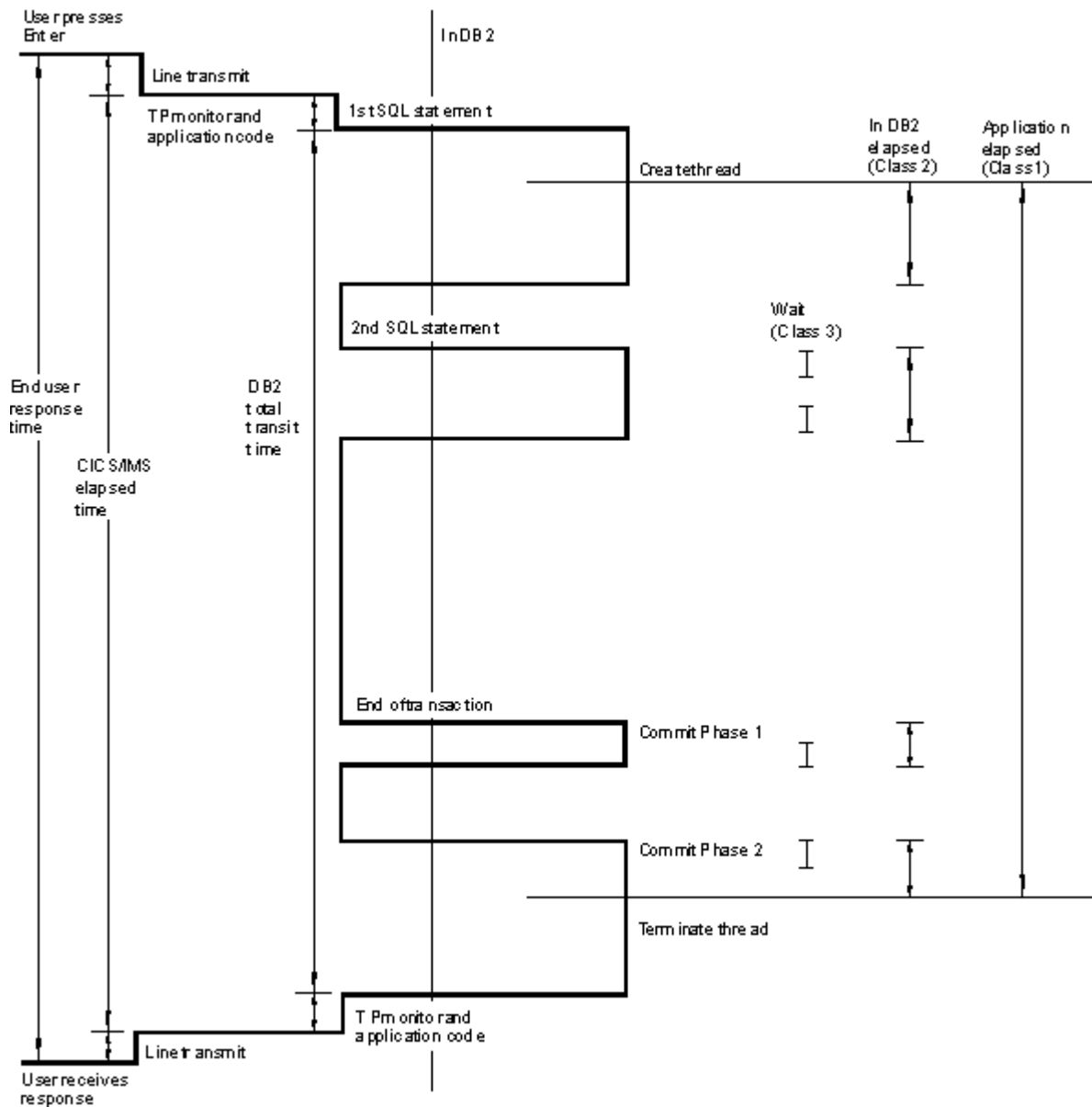

Figure 35. Relationship between different accounting times

Parallelism considerations

This section applies to threads that exploit CP parallelism or utility parallelism.

If a thread exploits parallelism, several tasks (called parallel tasks) are scheduled to perform the parallel work. For each of these tasks an Accounting record is generated, which contains counters and timers for the work performed by the particular task. In addition, the Accounting record for the thread contains the details about non-parallel work within the thread and also some parallel work-related data.

OMEGAMON XE for Db2 PE summarizes all Accounting records generated for such a thread and presents them as one logical Accounting record. [Table 5 on page 48](#) describes which values are a combination of the originating task's and parallel tasks' values and which are taken from the originating task only.

To avoid incorrect time values, the data collector must be active with CCP=YES switched on if query parallelism or utility parallelism is used. In this case, the data collector can collect data of parallel tasks that have already terminated.

For Sysplex parallelism, thread activity information is only shown for the originating task and for those parallel tasks that are executing on the same member as the originating task. Parallel tasks that are

executing on different members of the Sysplex group are ignored. Sysplex parallelism threads are marked by *S* next to the program name in the Thread Summary panel.

Especially interesting is the relationship between elapsed time, CPU time, and suspension times in the case of query parallelism or utility parallelism. The elapsed time is taken from the originating record while CPU and suspension times are calculated from all parallel and originating records. Consequently, both CPU time and suspension times can be larger than the elapsed time. Therefore, you can only get the full picture of the response time distribution if the times for each participating task are known. Produce a long Record trace for IFCID 3 using the Batch reporting facilities, especially if you suspect that the CPU times or suspension times for a thread where query parallelism or utility parallelism is used are large for other reasons than the times being added for several tasks. In a long Record trace, all Accounting records for parallel and originating threads are reported separately.

<i>Table 5. Query parallelism related data</i>	
Accounting Data	Derivation
Identifiers (PRIMAUTH, PLANNAME, and so on)	Originating task
Class 1 elapsed time	Originating task
Class 1 TCB times	Separate counters for originating task and sum of all parallel tasks
Class 2 elapsed time	Originating task
Class 2 TCB times	Separate counters for originating task and sum of all parallel tasks
Class 7 elapsed time	Originating task
Class 7 TCB times	Separate counters for originating task and sum of all parallel tasks
Class 2 and class 7 Db2 entry/exit events	Originating task
Class 3 and class 8 times	Separate counters for originating task and sum of all parallel tasks
Class 3 and class 8 events	Sum of originating task and all parallel tasks
Class 5 times	Originating task
SQL counters	Originating task
RID List counters	Sum of originating task and all parallel tasks
Query Parallelism counters	Originating task
Locking (including data-sharing-specific) counters	Sum of originating task and all parallel tasks
RLF data	Originating task
Buffer Pools counters	Sum of originating task and all parallel tasks
Group Buffer Pools counters	Sum of originating task and all parallel tasks
DDF counters	Originating task
Data Capture counters	Originating task

Thread Summary panel

Use the Thread Summary panel to view a list of active threads connected to the Db2 subsystem.

To display the Thread Summary panel, select option 1 (Display Thread Activity) from the Online Monitor Main Menu.

When the Thread Summary panel is initially displayed, class 1 and class 2 elapsed times are shown. Additional information is available to the right of the panel. You can press F20 (Right) to view the portions of the panel that are not displayed. [Figure 36 on page 49](#), [Figure 37 on page 49](#), [Figure 38 on page 50](#), and [Figure 39 on page 50](#) show the Thread Summary panel with all its possible fields.

Some fields can have values that are longer than the space available to show them in this panel. When this happens, the last character in the field is replaced with an asterisk (*) to indicate that the reported value is truncated.

```

DGOMTPLS 17:11          Thread Summary  SORT QUALIFY  ROW 1 TO 2 OF 2
PM05D851          D851 V10

To display a thread, place any character next to it, then press Enter.

  Primauth  Planname  Program      on  Requesting      Collection
  _ POD1    DSNESPRR  DSNESM6*    PM05D851VERYLON*  DSNESPR*
-  POD1    ADB      ADB2GET     PM05D851VERYLON*  ADBL
-  PODVRAT* PMOMDEV  N/P         PM05D851VERYLON*  N/P
-  DB2PM   PMOMDEV  DGO@SDOB   PM05D851VERYLON*  PMDEV
-  DB2PM   PMOMDEV  DGO@DB2I   PM05D851VERYLON*  PMDEV
-  DB2PM   N/P      N/P         PM05D851VERYLON*  N/P
-  DB2PM   N/P      N/P         PM05D851VERYLON*  N/P
-  CDL     PMOMDEV  N/P         PM05D851VERYLON*  N/P
-  DEA     PMOMDEV  N/P         PM05D851VERYLON*  N/P
-- End of Thread list --

Command ==> -----
F1=Help    F2=Split  F3=Exit    F5=Auto    F6=History  F7=Up
F8=Down    F9=Swap   F10=Qualify F11=Sort   F12=Cancel  F16=Look
F17=Collect F19=Left  F20=Right  F22=Purge

```

Figure 36. Thread Summary panel

```

DGOMTPLS 17:11          Thread Summary  SORT QUALIFY  ROW 1 TO 2 OF 2
PM01DLOC          DSN1 V10  GROUP001 MEMBER01

To display a thread, place any character next to it, then press Enter.

  Primauth  Planname  Program      --- Elapsed ---  ----- CPU -----
  _ USERT003 DSNESPCS DSNESM68      1.567556      Class 3      Class 1      Class 2
-  USERT004 DSNUTILS DSNESM68      1.910917      0.004357      0.001148
-- End of Thread list --

Command ==> -----
F1=Help    F2=Split  F3=Exit    F5=Auto    F6=History  F7=Up
F8=Down    F9=Swap   F10=Qualify F11=Sort   F12=Cancel  F16=Look
F17=Collect F19=Left  F20=Right  F22=Purge

```

Figure 37. Thread Summary panel (scrolled right once)

```

DGOMTPLS 17:11          Thread Summary  SORT QUALIFY  ROW 1 TO 2 OF 2
PM01DLOC          DSN1 V10  GROUP001 MEMBER01

To display a thread, place any character next to it, then press Enter.

  Primauth  Planname  Program          Request  Connection      Correlation
  _ USERT003  DSNESPCS  DSNESM68        Count  Type            ID
  _ USERT004  DSNUTILS  DSNESM68        4      DB2CALL         USERT003
  -- End of Thread list --

```

```

Command ==> -----
F1=Help      F2=Split      F3=Exit        F5=Auto        F6=History      F7=Up
F8=Down      F9=Swap       F10=Qualify    F11=Sort       F12=Cancel      F16=Look
F17=Collect  F19=Left     F20=Right     F22=Purge

```

Figure 38. Thread Summary panel (scrolled right twice)

```

DGOMTPLS 17:11          Thread Summary  SORT QUALIFY  ROW 1 TO 2 OF 2
PM01DLOC          DSN1 V10  GROUP001 MEMBER01

To display a thread, place any character next to it, then press Enter.

  Primauth  Planname  Program          Requesting      Collection
  _ USERT003  DSNESPCS  DSNESM68        Location       ID
  _ USERT004  DSNUTILS  DSNESM68        DSNAPC7       N/P
  -- End of Thread list --

```

```

Command ==> -----
F1=Help      F2=Split      F3=Exit        F5=Auto        F6=History      F7=Up
F8=Down      F9=Swap       F10=Qualify    F11=Sort       F12=Cancel      F16=Look
F17=Collect  F19=Left     F20=Right     F22=Purge

```

Figure 39. Thread Summary panel (scrolled right three times)

When the data collector is active, the Thread Summary panel also shows, besides other threads, the threads initiated by OMEGAMON XE for Db2 PE. Threads are collected for data collector tasks and for each Host Online Monitor user and Workstation Online Monitor user.

If many threads are active, use F7 (Up) and F8 (Down) to browse the list.

You can filter threads from being displayed in this panel using the QUALIFY command (see “QUALIFY command” on page 84). You can also specify the order in which the threads are listed using the SORT command (see “SORT command” on page 87).

The 1 field displays one of the following values:

Db2

The thread is currently processing within Db2.

I/O

The thread is performing I/O activity within Db2.

LOCK

The thread is engaged in locking activity within Db2.

EOT

The thread is in end-of-task processing.

APPL

Processing is occurring within the application.

I/S

The thread is in identify or signon state.

QUE

The value specified for MAXUSERS in the Db2 Install panel DSNTIPE has been met and the thread creation is queued until an available slot is found.

SP

The thread is running a stored procedure and is currently processing within Db2.

SPA

The thread is running a stored procedure, and processing is occurring outside Db2 (in stored procedure application code).

SPW

The thread is waiting for a stored procedure to be scheduled within Db2.

NTCB

Recoverable Resource Manager Services Attach Facility (RRSAF) agent has no TCB.

The identifier fields `Primauth`, `Planname`, `Package` or `DBRM`, `Connection ID`, and `Status` are highlighted in yellow when the status is DB2. Threads that are in I/O, Lock, SP, or SPW status are also highlighted in yellow because these are subsets of the DB2 status. The other fields in the Thread Summary panel are highlighted in reverse video when they are in exception status.

An asterisk (*) is shown to the left of the 1 field if the thread type is ALLIED DISTRIBUTED or DBAT.

When display exception processing is active, the exception fields displayed in the Thread Summary panel are checked for an exception condition each time the panel data is refreshed.

If you are filtering the threads listed in this panel, only the listed threads are checked for exception conditions. Threads in exception status are sorted to the top of the display, with *problem* level exceptions first and *warning* level exceptions second.

From the Thread Summary panel, you can select any thread to display the Thread Detail panel, where the thread can be examined in greater detail.

Thread Detail panel

Use the Thread Detail panel to view detailed information about the thread being monitored. From the Thread Detail panel, you can reach the Category windows, which show selected information about the monitored thread in greater detail.

To display the Thread Detail panel, select any active thread listed in the Thread Summary panel, Threads Holding Resource window, or the Periodic Exceptions List panel.

Some fields can have values that are longer than the space available to show them in this panel. When this happens, the last character in the field is replaced with an asterisk (*) to indicate that the reported value is truncated.

Note: The Thread Detail panel displayed at your site might have been tailored by your installation and consequently might not necessarily match the panel example shown in this information.

```

DGOMTPSM 13:24                      Thread Detail                      PM05D851 D851 V10
Command ==>> -----
For details, place any character next to heading, then press Enter.
More: +
- Thread Identification
  Primauth . . . . . : PODVRAT*      Correlation Name . . . . . : POD
  Planname . . . . . : PMOMDEV       Connection type . . . . . : DB2CALL
  Connection ID . . . : DB2CALL       Type . . . . . : ALLIED
  Requesting Location: PM05D851VERYLON* Status . . . . . : APPL
- Current DBRM . . . . . : N/P
- Times
  Class 1 . . . . . : 4.602666      Elapsed              CPU
  Class 2 . . . . . : N/P           0.000012
  Class 3 . . . . . : N/P           N/P
  Class 7 . . . . . : N/P           N/A
  Class 8 . . . . . : N/P           N/P
- Locking Activity
  Timeouts . . . . . : 0
  Deadlocks . . . . . : 0
  Suspensions . . . . . : 0
  Lock escalations . . . . . : 0
  Maximum page locks held . . . . . : 0
- Locked Resources
- RID List Processing
  Unsuccessful - any reason . . . . . : 0
- SQL Activity, Commits and Rollbacks
  DML . . . . . : 0 Commit . . . . . : 0
  DCL . . . . . : 0 Rollback . . . . . : 0
  DDL . . . . . : 0 Changes/Commit . . . . . : 0.0
- Buffer Manager Activity
  Getpage requests . . . . . : N/P
  Buffer updates . . . . . : N/P
  Prefetch requests . . . . . : N/P
  Synchronous I/O . . . . . : N/P
- SQL Statement and DBRM
  Distributed Data
  Requester elapsed time . . . . . : N/P
- IFI (Class 5) and Data Capture
- Query Parallelism Data
- Data Sharing Locking Activity
  F1=Help      F3=Exit      F5=Auto      F6=History   F7=Up        F8=Down
  F12=Cancel   F16=Look     F17=Collect  F22=Purge

```

Figure 40. Thread Detail panel

If you have enabled display exception processing, all fields in exception status are shown in reverse video, and the color indicates the level of the exception. *Warning* level exceptions are highlighted in yellow, while *problem* level exceptions are highlighted in red. Categories that can be selected from this panel are shown in reverse video when their next level windows contain fields in exception status.

If DBRM is used, the Current Package field displayed in the Thread Detail panel is shown as Current DBRM instead.

The following list describes some of the important fields that are shown in this panel:

Type

The type of the thread being monitored.

ALLIED

The thread is not involved in any distributed activity.

A-DIST

The thread is initiated by a Db2 attach and requests data from one or more server locations.

DBAT

The thread is initiated by, and performing work on behalf of, a remote (requester) location.

D-DIST

Distributed database access thread, both a DDF server and requester.

It is important to know whether the thread is involved in distributed activity, because this can affect the fields that should be monitored. For example, if the thread is involved in distributed activity, the

class 1 elapsed time is higher than if there was no distributed activity, because this time includes network time.

Class 1 Times

This field shows the elapsed time and the CPU time for the processing performed and includes the time spent not only in Db2 but also in the application.

CPU time is the sum of:

- The agent's CPU (TCB) time
- The CPU time spent in stored procedures
- The accumulated processing time of the parallel tasks (if query parallelism or utility parallelism is used)

Class 2 Times

This field shows the elapsed time and the CPU time for the processing performed in Db2 only. Elapsed time includes wait times.

CPU time is the sum of:

- The agent's CPU (TCB) time
- The CPU time spent in stored procedures
- The accumulated processing time of the parallel tasks (if query parallelism or utility parallelism is used)

For threads that exploit query parallelism or utility parallelism, class 2 CPU time can be larger than class 2 elapsed time because the CPU time includes the execution time of all parallel threads. To separate the agent's CPU time from the sum of all parallel tasks' CPU times, select **Times**, which displays the Thread Times window. See also the discussion at the beginning of [“Accounting times” on page 46](#).

Class 3 Times

This field shows the total time spent waiting because of class 3 suspensions. For threads that exploit query parallelism or utility parallelism, wait times are summed for the originating task and all parallel tasks. See also the discussion at the beginning of [“Accounting times” on page 46](#).

Suspensions

This field includes all types of lock suspensions.

Getpage requests

This field shows the number of Getpage requests. Reducing Getpage requests reduces CPU usage and improves performance. Fewer Getpage requests also result in fewer synchronous reads, because fewer pages that are not in the buffer pool must be fetched.

Prefetch reads

This includes number of Prefetch reads done because of Sequential Prefetch, List Prefetch, and Dynamic Prefetch.

Synchronous I/O

This includes both synchronous reads and synchronous writes.

Thread Activity windows

You can access several windows from the Thread Detail panel. To reach a window, type any character in the space beside the heading you want. Several windows can be accessed simultaneously. The windows are overlaid in the Thread Detail panel. To leave the current window and proceed with the next window, press F3 (Exit). To cancel all windows and return to the Thread Detail panel, press F12 (Cancel).

Thread Identification window

Use the Thread Identification window to examine the identification data about the thread being monitored.

To display this window, select **Thread Identification** from the Thread Detail panel.

Some fields can have values that are longer than the space available to show them in this panel. When this happens, the last character in the field is replaced with an asterisk (*) to indicate that the reported value is truncated.

```

DGOMTWDID          Thread Identification

More:  - +

Thread type . . . . . : ALLIED
Status . . . . . : In DB2
Parallelism . . . . . : CP
Primauth . . . . . : USER029*
Origauth . . . . . : USER029*
Planname . . . . . : DB2PMPLN
Connection ID . . . . . : DB2CALL
Connection type . . . . . : DB2 CALL
Correlation name . . . . . : USER029
Correlation number . . . . . :
Requesting location . . . . . : PM05D851LOCATI*
LUW Network ID . . . . . : APCNET
LUW LU Name . . . . . : SYDAPC6
LUW Instance Number . . . . . : X'A80C8803FF31'
LUW Sequence Number . . . . . : 1
Token . . . . . : N/P
Command ==>
-----
F1=Help   F2=Split   F3=Exit   F5=Auto   F6=History F7=Up
F8=Down   F9=Swap    F12=Cancel F16=Look  F17=Collect F22=Purge

```

Figure 41. Thread Identification window

From the Thread Identification window, you can select Requester Correlation to display the Requester Correlation Data window.

The following list describes some of the important fields that are shown in this window:

Status

The status of the thread. If Parallelism is 'CP', the status 'In DB2' means that the originating task is in Db2.

Primauth

The primary authorization ID from connection or signon. This is SYSOPR for MVS operator commands and Db2 system internal agents. The connection authorization exit and the signon authorization exit can change the primary authorization ID so that it is not the same as the original primary authorization ID. Distributed authorization ID translation can also change the primary authorization ID.

Planname

The name of the plan produced during the bind process and used by Db2 to process SQL statements encountered during statement execution. Examples of plan names are DSNUTIL for utility, DSNBIND for bind activity, DISTSERV for remote unit of work, and the application plan name for CICS and IMS.

Correlation Name

The correlation name for the thread.

For further details, see [“Correlation ID translation” on page 20.](#)

Correlation Number

The correlation number for the thread.

For further details, see [“Correlation ID translation” on page 20.](#)

LUW Network ID

The logical unit of work ID (LUWID), consisting of the network ID, LU name, instance number, and sequence number, identifies a thread within a network and is used to correlate local and remote activity for a single distributed transaction.

LUW LU Name

See LUW Network ID.

LUW Instance Number

See LUW Network ID.

LUW Sequence Number

See LUW Network ID.

RRSAF Accounting token

This field shows the Accounting token as defined during signon for a thread using the RRS attachment facility.

Recovery token

This field is used to correlate Online Monitor display with a CICS inquire task display.

Requester Correlation Data window

Use the Requester Correlation Data window to view information about the correlation data belonging to the originator (initial requester) of the distributed transaction. One of four different Requester Correlation Data windows is displayed depending on the requester type.

The following figure shows an example of a Requester Correlation Data window.

```
DGOMTWMV          Requester Correlation Data
Primauth . . . . . : USER029
Plan Name . . . . . : DSNEPC5
Connection ID . . . . . : TSO
Connection type . . . . . : BATCH
Correlation name . . . . . : USERT003
Correlation number . . . . . :
Location . . . . . : PM01DLOC
Product ID . . . . . : DB2
Product Version . . . . . : V10 R1 M0
Network ID . . . . . : APCNET
LU Name . . . . . : SYDAPC5
MVS Accounting token

D01M300

Command ==>
F1=Help   F2=Split   F3=Exit   F5=Auto   F6=History F9=Swap
F12=Cancel F16=Look   F17=Collect F22=Purge
```

Figure 42. Requester Correlation Data window for a Db2 Requester

Current Package/DBRM window

To display this window, select **Current Package** or **Current DBRM** from the Thread Detail panel. One of two possible windows is displayed depending on whether the thread currently uses a package or a DBRM.

Some fields can have values that are longer than the space available to show them in this panel. If this happens, the last character in the field is replaced with an asterisk (*) to indicate that the reported value is truncated.

```

DGOMTWPK                               Current Package

More: - +
Location . . . . . : PM05D851LOCATIO*
Collection ID . . . . . : TEST_COLLECTION_XX
Program name . . . . . : CUSTINQR
Consistency token . . . . . : 'A2B984F82EA779093'X

DB2 entry/exit events . . . . . :          13
SQL statements issued . . . . . :          6

                                     Total      Current
                                     Execution  Execution
Elapsed time (Class 7) . . . . . : 13.000000 10.000000
CPU time . . . . . : 2.000000 N/A
  TCB . . . . . : 1.500000 N/A
  Parallel tasks . . . . . : 0.500000 N/A
Waiting time . . . . . : 11.500000 N/A
Suspension time (Class 8) . . . . . : 10.000000 N/A
  TCB . . . . . : 10.000000 N/A
  Parallel tasks . . . . . : 0.000000 N/A
Not accounted . . . . . : 1.500000 N/A

                                     Elapsed time  Events
Suspensions (Class 8) . . . . . : 10.000000 760
Locks and latches . . . . . : 5.000000 200
Synchronous I/O . . . . . : 2.000000 100
Other read I/O . . . . . : 1.000000 50
Other write I/O . . . . . : 0.500000 9
Services task switch . . . . . : 0.500000 400
Archive log (quiesce) . . . . . : 0.000000 0
Archive log read . . . . . : 1.000000 1
Drain lock . . . . . : 0.000000 0
Claim release . . . . . : 0.000000 0
Page latch . . . . . : 0.000000 0
Stored procedures . . . . . : 0.000000 0
Notify messages . . . . . : 0.000000 0
Global contention . . . . . : 0.000000 0

Command ==> -----
F1=Help      F2=Split    F3=Exit     F5=Auto     F6=History
F7=Up        F8=Down     F9=Swap     F12=Cancel  F16=Look
F17=Collect  F22=Purge

```

Figure 43. Current Package window

Use the Current Package window to view information about the location, identification, and execution times of various functions performed by or on the current package.

Some fields can have values that are longer than the space available to show them in this panel. When this happens, the last character in the field is replaced with an asterisk (*) to indicate that the reported value is truncated.

```

DGOMTWDB                               Current DBRM

Program Name . . . . . : CUSTINQR
DB2 entry/exit events . . . . . : 13
SQL statements issued . . . . . : 6

                                         Total      Current
                                         Execution  Execution
Elapsed time (Class 7) . . . . . : 13.000000 10.000000
CPU time . . . . . : 2.000000 N/A
  TCB . . . . . : 1.500000 N/A
  Parallel tasks . . . . . : 0.500000 N/A
Waiting time . . . . . : 11.500000 N/A
Suspension time (Class 8) . . . . . : 10.000000 N/A
  TCB . . . . . : 10.000000 N/A
  Parallel tasks . . . . . : 0.000000 N/A
Not accounted . . . . . : 1.500000 N/A

Command ==> -----
F1=Help      F2=Split    F3=Exit     F5=Auto     F6=History
F7=Up        F8=Down     F9=Swap     F12=Cancel  F16=Look
F17=Collect  F22=Purge

```

Figure 44. Current DBRM window

Use the Current DBRM window to view information about the identification and execution times of various functions performed by or on the current DBRM.

See “Accounting times” on page 46 for a discussion of how to interpret the time values for threads that exploit query parallelism or utility parallelism. These considerations apply to class 7 times (for elapsed times and CPU times) and to class 8 times (for suspension times).

The following list describes some of the important fields that are shown in this window:

Not accounted

This is derived as **Waiting time - Suspension time (Class 8) TCB**. It includes CPU wait times, paging, and open/close activity.

Suspensions (Class 8)

If **Waiting time** and **Suspension time (Class 8)** are almost the same, examine the reasons for suspensions that caused the wait. Otherwise, examine the **Not accounted** field in the Thread Times window.

Locks and latches

This field shows the duration of suspensions resulting from a lock or latch not being available immediately on request. If the suspension time is high, examine the Locking (IRLM) Activity window.

Synchronous I/O

This field shows the accumulated I/O elapsed wait time for I/O performed under this thread. This field is for synchronous I/O only. It includes synchronous Read and Write I/O. If the time per I/O is high, one typical problem is an interference by Prefetch or Deferred Write I/O.

Other read I/O

This field includes waits caused by Read I/O performed under another thread, for example, Sequential Prefetch, List Prefetch, or Dynamic Prefetch.

If the value in this field is high, the problem could be an I/O bound query using Prefetch or an I/O contention. If it is an I/O bound query, DEGREE ANY could drastically improve elapsed time of such a query. The application is accessing data from a busy data set/volume/control unit and is continually being suspended. The DBA and the MVS system programmer should be consulted.

Other write I/O

This field includes waits caused by Write I/O performed under another thread, for example, asynchronous Write.

If the value in this field is high, the problem could be I/O contention. The application is accessing data from a busy data set/volume/control unit and is continually being suspended. The DBA and the MVS system programmer should be consulted to resolve possible data set placement problems.

Too small a buffer pool for sort and other updated data could also cause this problem.

Services task switch

Included here are waits because of OPEN/CLOSE data set, SYSLGRNX update, COMMIT PHASE II for UPDATE threads, HSM recall for data set, data space manager services, DEFINE, EXTEND, and DELETE data set, and the log I/Os for COMMIT and UPDATE processing.

Wait times in COMMIT are reported in the following fields:

TSO/CAF/Batch single phase commit:

SER.TASK SWTCH

CICS/IMS phase 1 commit:

SYNCHRON. I/O

CICS/IMS phase 2 commit:

SER.TASK SWTCH

This means, for example, that an IMS COMMIT used to have 2 synchronous I/O suspensions, whereas now it has 1 synchronous I/O suspension and 1 service task suspension.

Both single and dual logs result in the same count.

There is no overlap between the elapsed time reported in this field and the other class 3 elapsed times. If service task suspensions overlap other types of suspensions, the other types of suspensions are ignored.

Preformatting the data sets is probably most important in terms of service task suspension.

Archive log (quiesce)

Included here are waits because of processing of the ARCHIVE command (not the time for the ARCHIVE command to complete).

Avoid issuing ARCHIVE LOG QUIESCE during peak periods.

Archive log read

Accumulated wait time for archive reads (from tape).

Drain lock

The time spent waiting because of drain lock suspensions. If the value is large, it can indicate that the execution of a utility affects the SQL.

Claim release

The time spent waiting for claims to be released.

Page latch

The time spent waiting for page latch contentions.

Thread Times window

Use the Thread Times window to investigate the response times of different actions performed by the thread.

See [“Accounting times” on page 46](#) for a discussion on how to interpret the time values for threads that exploit query parallelism or utility parallelism.

To display this window, select Times from the Thread Detail panel.

```

DGOMTWTI                                Thread Times

                                           Class 1          Class 2          More - +
                                           In Appl         In DB2          Outside DB2
Elapsed time . . . . . : 29.504644      1.188735      28.315910
CPU time . . . . . : 0.135267         0.064602      0.070665
TCB . . . . . : 0.135267           0.064602      0.070665
TCB - Stored Proc . . . . . : 0.000000      0.000000
Parallel tasks . . . . . : 0.000000      0.000000
Waiting time . . . . . : N/A          1.124133
Suspension time . . . . . : N/A        1.121289
TCB . . . . . : N/A          1.121289
Parallel tasks . . . . . : N/A        0.000000
Not accounted . . . . . : N/A        0.002844

                                           Time          Event
Suspensions (Class 3) . . . . . : 1.121289      73
Locks and latches . . . . . : 0.000000      0
Synchronous I/O . . . . . : 0.358523      57
Other read I/O . . . . . : 0.762766      16
Other write I/O . . . . . : 0.000000      0
Services Task switch . . . . . : 0.000000      0
Archive log (quiesce) . . . . . : 0.000000      0
Archive log read . . . . . : 0.000000      0
Drain lock . . . . . : 0.000000      0
Claim release . . . . . : 0.000000      0
Page latch . . . . . : 0.000000      0
Stored procedures . . . . . : 0.000000      0
Notify messages . . . . . : 0.000000      0
Global contention . . . . . : 0.000000      0

DB2 entry/exit events
Non stored procedures . . . . . :          195
Stored procedures . . . . . :          0

Class 5 (IFI)
Elapsed Time . . . . . :          N/P
TCB Time . . . . . :          N/P

Command ==>
-----
F1=Help   F2=Split   F3=Exit   F5=Auto   F6=History F7=Up
F8=Down   F9=Swap    F12=Cancel F16=Look  F17=Collect F22=Purge

```

Figure 45. Thread Times window

Class 1, 2, and 3 times can help guide your investigation into application performance and tuning.

Class 2 and 3 times are reported only if monitor trace classes 2 and 3 are active.

Class 2 and 3 times are not updated until the thread completes its current call to Db2. For example, during execution of a long running SQL statement, class 2 and 3 times are not updated until after the SQL process has ended. Consequently, class 2 and 3 times are estimated when the thread is in Db2.

The following list describes some of the important fields that are shown in this window:

Suspensions (Class 3)

Total time spent waiting because of various suspensions covered by monitor trace class 3.

Locks and latches

This field shows the duration of suspensions resulting from a lock or latch not being available immediately on request. If the suspension time is high, examine further the Locking block in the Accounting report.

Synchronous I/O

This field shows the accumulated I/O elapsed wait time for I/O performed under this thread. This field is for synchronous I/O only. It includes synchronous Read and Write I/O. If the time per I/O is high, one typical problem is an interference by Prefetch or Deferred Write I/O. The I/O scheduling enhancement in current Db2 releases should reduce this problem by assigning higher I/O priority to synchronous I/O over asynchronous I/O.

Other read I/O

This field includes waits caused by Read I/O performed under another thread, for example, Sequential Prefetch, List Prefetch, or Dynamic Prefetch.

If the value in this field is high, the problem could be an I/O bound query using Prefetch or an I/O contention. If it is an I/O bound query, DEGREE ANY could drastically improve elapsed time of such a query. The application is accessing data from a busy data set/volume/control unit and is continually being suspended. The DBA and the MVS system programmer should be consulted.

Other write I/O

This field includes waits caused by write I/O performed under another thread, for example, asynchronous write.

If the value in this field is high, the problem could be I/O contention. The application is accessing data from a busy data set/volume/control unit and is continually being suspended. The DBA and the MVS system programmer should be consulted to resolve possible data set placement problems.

Too small a buffer pool for sort and other updated data could also cause this problem.

Archive log (quiesce)

Included here are waits because of processing of the ARCHIVE command (not the time for the ARCHIVE command to complete).

Avoid issuing ARCHIVE LOG QUIESCE during peak periods.

Archive log read

Accumulated wait time for archive Reads (from tape).

Drain lock

The time spent waiting because of drain lock suspensions. If the value is large, it can indicate that the execution of a utility affects the SQL.

Claim release

The time spent waiting for claims to be released.

Page latch

The time spent waiting for page latch contentions.

Locking (IRLM) Activity window

Use the Locking (IRLM) Activity window to view information about locking activity for the thread being monitored.

To display this window, select Locking Activity from the Thread Detail panel.

```

DGOMTWLK          Locking (IRLM) Activity

Lock and latch suspensions . . . . . More:      +
Elapsed time . . . . . : 0.000355

Timeouts . . . . . : 0
Deadlocks . . . . . : 0
Lock requests . . . . . : 19
Unlock requests . . . . . : 18
Change requests . . . . . : 1
Query requests . . . . . : 0
Other IRLM requests . . . . . : 0
Suspensions - lock . . . . . : 0
Suspensions - latch . . . . . : 1
Suspensions - other . . . . . : 0
Lock escalations - shared . . . . . : 0
Lock escalations - exclusive . . . . . : 0
Maximum page or row locks held . . . . . : 2
Claim requests . . . . . : 6
Unsuccessful claim requests . . . . . : 0
Drain requests . . . . . : 0
Unsuccessful drain requests . . . . . : 0

Command ==>
F1=Help      F2=Split    F3=Exit     F5=Auto     F6=History
F7=Up        F8=Down     F9=Swap     F12=Cancel  F16=Look
F17=Collect  F22=Purge

```

Figure 46. Locking (IRLM) Activity window

Deadlocks and timeouts displayed in this window can indicate the existence of locking problems. These problems can be further investigated using the Locked Resources window to examine resources that are either locked by or, if they are locked by another thread, unavailable to, the monitored thread.

The following list describes some of the important fields that are shown in this window:

Timeouts

Number of times lock suspension ultimately resulted in a timeout. This happens when a requester for a lock on a resource has waited longer than the installation-specified RESOURCE TIMEOUT limit in the Db2 Install panel DSNTIPI.

Deadlocks

Number of times lock suspension ultimately resulted in a deadlock. This happens when two or more application processes each hold locks on resources that the others need, without which they cannot proceed. A single process accessing data through an unclustered index can sometimes experience a deadlock between a data page and an index page. If deadlocks are not very frequent, they might not affect performance.

Lock requests

Number of times a lock on a resource was requested.

Change requests

Number of times a lock change was requested, for example, to promote a shared page lock to exclusive lock.

Suspensions - lock

Number of resource conflicts. A suspension is a wait for a lock, and each of these waits can adversely affect application performance. The suspension might ultimately result in normal resumption, timeout, or deadlock. The number of lock suspensions is a function of the lock requests. Lock suspensions (or conflicts) can occur on either lock requests or change requests.

The ratio of suspensions to lock requests is largely application dependent.

Lock escalations - shared

Count of lock escalations to shared mode. Number of times the LOCKS PER TABLE(SPACE) parameter in the Db2 Install panel DSNTIPJ was exceeded and the table space lock was promoted from a page lock (IS) to a table space lock (S) for this thread. Escalation can cause unpredictable response times. The lock escalation to shared mode should only happen on an exception basis. For example, if a REPEATABLE READ application references most pages in a table.

Lock escalations - exclusive

Count of lock escalations to exclusive mode. Number of times the LOCKS PER TABLE(SPACE) parameter in the Db2 Install panel DSNTIPJ was exceeded and the table space lock was promoted from a page lock (IX) to a table space lock (X) for this thread. Escalation can cause unpredictable response times. The lock escalation to exclusive mode should happen rarely, for example, if an application updates many pages in a table without issuing commits.

Check the exception event display for deadlocks occurring against the agent that causes the lock escalation. In a transaction processing environment, a moderate level of lockout is tolerable. If many escalations cause deadlocks and timeouts, you can change the escalation threshold value. Use of ANY is extremely desirable to prevent unnecessary and expensive page locks, for example locking all pages in a table space.

Lock escalations, shared or exclusive, should not be expected in a transaction environment.

If escalation occurs when LOCKSIZE ROW or LOCKSIZE PAGE is specified, the lock is escalated to the table level for a segmented table space and to the table space level for a nonsegmented table space.

A new clause LOCKMAX has been added to the CREATE TABLESPACE statement. This provides for control of the maximum number of locks for an individual table space in addition to the system-wide NUMLKTS parameter currently provided.

The default is LOCKMAX 0 to ensure that PAGE level locking is consistent with previous releases of Db2. If LOCKSIZE ANY is specified, Db2 chooses LOCKSIZE PAGE LOCKMAX SYSTEM.

Escalation is now possible with PAGE locking by specifying the LOCKMAX clause. This provides for initial PAGE level locking with escalation to table or table space locking for segmented and nonsegmented table spaces respectively, based on the number of locks specified on the LOCKMAX clause. To disable escalation, specify LOCKMAX 0.

For high volume updates where contention is an issue, use type-2 indexes and specify one of the following:

- LOCKSIZE PAGE
- LOCKSIZE ROW for the high contention tables to improve concurrency. However, LOCKSIZE ROW should be considered only as an exceptional case, because of a potential for significant overhead. In fact, it is even possible that LOCKSIZE ROW causes deadlocks, which would not happen with LOCKSIZE PAGE.

Omitting LOCKMAX results in LOCKMAX 0, which disables escalation. If escalation is to be allowed, users should carefully consider the threshold at which it should take place for each individual table.

Maximum page or row locks held

Count of the maximum number of page or row locks concurrently held against all table spaces by a single thread during its execution. This count cannot exceed the value of the "LOCKS PER USER" Db2 installation parameter (panel DSNTIPJ). After the limit is reached, the next attempt to obtain a lock results in a RESOURCE UNAVAILABLE return code, and the SQL request is not processed.

Locking considerations

The following aspects should be considered if concurrency is an issue:

- Consistent data access sequence in applications
- The mix of concurrent processing types (batch and transaction)
- IRLM startup procedure options and Db2 installation options
- DDL LOCKSIZE
- DDL LOCKMAX
- BIND parameters

See [*IBM Db2 for z/OS in the IBM Knowledge Center*](#) for detailed information.

Locked Resources window

Use the Locked Resources window to view the list of thread resources that are either locked by or, if they are locked by another thread, unavailable to, the monitored thread. If many resources are listed, you can use the scrolling keys F7 (Up) and F8 (Down) to browse the list.

The resources are listed in the following sequence:

1. Resources that cause this thread to be suspended
2. Resources that cause other threads to be suspended
3. Resources that are held by more than one thread
4. Resources that are held only by this thread

To display this window, select Locked Resources from the Thread Detail panel.

```

DGOMTWLD                               Locked Resources                               ROW 1 TO 1 OF 1

For a list of all the threads that have a lock on a resource, place any
character next to the resource, then press Enter.

      Database      Type      Status      Duration      Attribute
      Object        Count    Suspended   Function
-     DB2PMOM       3        NO          N/A           L-LOCK
***** BOTTOM OF DATA *****

Command ==>
F1=Help      F2=Split    F3=Exit     F5=Auto      F6=History   F7=Up
F8=Down      F9=Swap     F12=Cancel  F16=Look    F17=Collect  F22=Purge

```

Figure 47. Locked Resources window

From this window you can display all holders and requesters of any Db2 resource listed. Select any locked resource from this window to display the Threads Holding Resource window, where you can examine a list of threads competing for the resource. For more information, see [“Threads Holding Resource window” on page 63](#).

You can use the Locked Resources window and the Threads Holding Resource window to examine potential timeouts and deadlocks and to determine whether Db2 resource contention is the cause for long running threads. Whenever a long class 3 lock/latch elapsed time is indicated in the Thread Detail or Thread Times panels, you can use the Locked Resources window to check for suspensions.

The following list describes some of the important fields that are shown in this window:

Type

This field shows the resource involved.

PAGESET indicates that the object is either a table space or index. The ACQUIRE and RELEASE parameters for the plans, and the RELEASE parameter for the packages involved should be investigated if the lock is suspended.

DATAPAGE./ROW indicates the object is an actual page of data. Check the ISOLATION level for the plans and packages if the lock is suspended.

INDEX indicates the object is an index page or a subpage. The number of subpages per page in the index should be investigated if the lock is suspended.

PAGE indicates the object is a data page. In this case the request type is always LATCH, which indicates a page latch request.

Threads Holding Resource window

Use the Threads Holding Resource window to view information about the locked resource selected from the Locked Resource window. The Threads Holding Resource window displays a list of all holders and requesters of the locked resource. If many threads are listed, you can use the scrolling keys F7 (Up) and F8 (Down) to browse the list.

To display the Threads Holding Resource window, select any locked resource listed in the Locked Resources window. The Threads Holding Resource window is then displayed. To leave the window and return to the Locked Resources window, press F3 (Exit). To leave the window and return to the Thread Detail panel, press F12 (Cancel).

The appearance of the Threads Holding Resource window differs depending on the type of resource being held by the monitored thread. [Figure 48 on page 64](#) shows an example of a Threads Holding Resource window.

```

DGOMTWR5          Threads Holding Resource          ROW 1 TO 2 OF 2
Command ===> -----

To display a new thread, place any character next to it, then press Enter.
The Thread Detail will be displayed.

Resource type . . . . . : DBD PLCK Database . . : DSNDDB06

      Primauth      Corname      Status      Subsystem
      Planname      Connection  Suspended   Duration
-   TRIONA         TRIONA      IS          N/P
-   DB2PMOM        DB2CALL     NO          ALLOCATION
-   N/P            N/P         IS          DSN1
-   N/P            N/P         NO          N/P
***** BOTTOM OF DATA *****

F1=Help      F2=Split      F3=Exit      F5=Auto      F6=History    F7=Up
F8=Down      F9=Swap       F12=Cancel   F16=Look     F17=Collect   F22=Purge

```

Figure 48. Threads Holding Resource window

You can display the Thread Detail panel for any of the threads listed in these windows by typing any character in the selection field beside the thread and pressing Enter.

Use the Threads Holding Resource window and the Locking (IRLM) Activity window to examine timeout or deadlock situations or to determine whether Db2 resource contention is the cause for long running threads.

RID List Processing window

Use the RID List Processing window to view information about the number of successful and unsuccessful RID (Record ID) list processing operations performed. This information can help you determine the maximum number of RID blocks to allocate for optimum system performance.

To display this window, select RID List Processing from the Thread Detail panel.

```

DGOMTWRP          RID List Processing

Successful . . . . . : 0
Not used - no storage . . . . . : 0
Not used - limit exceeded . . . . . : 0

Command ===> -----
F1=Help      F2=Split      F3=Exit      F5=Auto
F6=History    F9=Swap       F12=Cancel   F16=Look
F17=Collect   F22=Purge

```

Figure 49. RID List Processing window (Thread Activity)

The following list describes some of the important fields that are shown in this window:

Successful

A nonzero value in this field indicates that Db2 has used List Prefetch activity. If you are looking at a transaction and List Prefetch is used, you might want to look into the access path selection.

Not used - no storage

Number of times RID list processing was terminated because of insufficient storage.

This failure occurs when a RID list was not used for a given RID list process involving one or more indexes because no storage was available to hold the list of RIDs.

Not used - limit exceeded

Number of times RID list processing was terminated because of one or more internal limits exceeded.

The cause of the failure should be investigated, either from statistics record or from performance trace, before increasing the RID list storage size. Without proper investigation, merely increasing the RID list storage size might not solve the problem.

SQL Activity window

Use the SQL Activity window to view the number of executions of SQL statements during the processing of a Db2 application, for the monitored thread.

To display this window, select `SQL Activity`, `Commits`, and `Rollbacks` from the Thread Detail panel.

```

DGOMTWSQ          SQL Activity
More:            - +
Incremental bind . . . . . : 0
Reoptimization . . . . . : 0
Prepare statement match . . . . . : 0
Prepare statement no match . . . . . : 0
Implicit prepare . . . . . : 0
Prepare from cache . . . . . : 0
Cache limit exceeded . . . . . : 0
Prepare statement purged . . . . . : 0
Commit . . . . . : 0
Rollback . . . . . : 0
Changes/Commit . . . . . : 0.0

Total DML . . . . . : 108
  Select . . . . . : 2
  Insert . . . . . : 0
  Update . . . . . : 0
  Delete . . . . . : 0
  Prepare . . . . . : 10
  Describe . . . . . : 0
  Describe table . . . . . : 0
  Open . . . . . : 3

  Close . . . . . : 3
  Fetch . . . . . : 90

Total DCL . . . . . : 4
  Lock table . . . . . : 0
  Grant . . . . . : 4
  Revoke . . . . . : 0
  Set SQLID . . . . . : 0
  Set host variable . . . . . : 0
  Set current degree . . . . . : 0
  Connect type 1 . . . . . : 0
  Connect type 2 . . . . . : 0
  Set connection . . . . . : 0
  Release . . . . . : 0
  Set current rules . . . . . : 0
  SQL call . . . . . : 0
  Associate locators . . . . . : 0
  Allocate cursor . . . . . : 0

Total DDL . . . . . : 5
  Rename table . . . . . : 0
  Comment on . . . . . : 0
  Label on . . . . . : 0

          Create      Drop      Alter
Table . . . . . :      1      1      0
Temp. Table . . :      0      N/A    N/A
Index . . . . . :      0      0      0
Tablespace . . . :      0      0      0
Database . . . . :      0      0      0
Stogroup . . . . :      0      0      0
Synonym . . . . . :      0      0      N/A
View . . . . . :      0      0      N/A
Alias . . . . . :      3      0      N/A
Package . . . . . :      N/A     0      N/A

Command ==> -----
F1=Help      F2=Split    F3=Exit    F5=Auto
F6=History   F7=Up       F8=Down    F9=Swap
F12=Cancel   F16=Look    F17=Collect F22=Purge

```

Figure 50. SQL Activity window (Thread Activity)

This information displays the number of times specific SQL statements were executed for the thread being monitored.

The SQL Activity window consists of the following sections:

Total DML

This section shows the number of executions performed by various SQL statements concerning the manipulation of data.

Total DCL

This section shows the number of executions performed by various SQL statements concerning the controlling of various activities.

Total DDL

This section shows a table that contains the number of executions performed by various DDL SQL statements for each of the applicable object types. These SQL statements are used to create, drop, and alter objects.

If you are looking at a transaction and there are nonzero values for Describe, Describe Table, or Prepare, it is an indication that the transaction is involved in dynamic SQL activity. However, this is unlikely and you can investigate further.

If you are looking at a transaction, it is unlikely that you would see any SQL DCL or SQL DDL activity. However, if there is any SQL DDL activity, be sure to use frequent commits to minimize Db2 catalog contention.

The following list describes some of the important fields that are shown in this window:

Incremental bind

The number of incremental binds that took place.

If a plan is bound with VALIDATE(RUN), Db2 performs validity checks at bind time and rechecks any failures at run time. This can result in catalog contention and degraded application performance, depending on the number of statements flagged and how many times they are executed. Avoid VALIDATE(RUN) as much as possible. Ensure that all objects are created and all privileges are granted before bind, and select the VALIDATE(BIND) option.

In addition to plans bound with VALIDATE(RUN), this counter is incremented for plans using Db2 private protocol.

Reoptimization

The total number of times reoptimization of the access path for static and dynamic SQL queries occurred during execution time.

Reoptimization can be triggered by the option REOPT(VARS) for BIND and REBIND PLAN and PACKAGE. Reoptimization is intended for statements with host variables, parameter markers, and special registers with access paths that are so inappropriate that the performance improvement of the reoptimized path outweighs the overhead caused by the reoptimization.

Commit

The number of Commit phase 1, Commit phase 2, read only Commit and single phase Commits (syncs) that completed successfully.

Changes/Commit

This ratio shows the inserts, updates, and deletes per commit and rollback.

This ratio is useful in monitoring the frequency of Commits. Too many updates per commit means a long running unit of recovery, which degrades IRLM performance and can prolong recovery in case of a failure. Too few updates per commit hampers performance, since log writes are involved. If necessary, look into the application to establish commit points appropriately.

The commit frequency can vary between online transactions and batch jobs.

Buffer Manager Activity window

Use the Buffer Manager Activity window to view all buffer pools used by the thread.

To display this window, select Buffer Manager Activity from the Thread Detail panel.

```

DGOMTWBM          Buffer Manager Activity          ROW 1 TO 4 OF 4

For additional details, type any character next to Buffer Pool ID,
then press Enter.

  Buffer Pool      Getpage      Buffer Pool      Synchronous      Buffer Updates
  ID              Requests      hit ratio      Read I/O
- BP0              111           75.7           0                 50
- BP7              200           33.2           0                 125
- BP32K7          311           47.3           0                 25
- Total           622           47.8           0                 200
--- End of Buffer Pool List ---

Command ==> -----
F1=Help        F2=Split      F3=Exit       F5=Auto       F6=History
F7=Up          F8=Down       F9=Swap       F12=Cancel    F16=Look
F17=Collect    F22=Purge

```

Figure 51. Buffer Manager Activity window

You can select any buffer pool ID listed in this window to display the Buffer Pool Detail window, where you can view information about read and write activity both to and from that particular buffer pool, or select Total to view information about all of the listed buffer pools combined.

By examining buffer pool read and write activity, you can determine the buffer pool sizes for optimum system performance.

Buffer Pool Detail window

Use the Buffer Pool Detail window to view information about the buffer pool selected from the Buffer Manager Activity window. These statistics show read and write activity both to and from that buffer pool. If Total was selected from the Buffer Manager Activity window, this window displays the combined statistics of all buffer pools used by the thread.

To display this window, select a buffer pool ID or Total from the Buffer Manager Activity window.

```

DGOMTWBD          Buffer Pool Detail

Buffer pool ID . . . . . : BP0
Buffer pool hit ratio (%) . . . . . : 41.3
Getpage requests . . . . . : 111
Buffer updates . . . . . : 50
Sequential prefetch requests . . . . . : 14
List prefetch requests . . . . . : 1
Dynamic prefetch requests . . . . . : 1
Synchronous read I/O . . . . . : 27
Synchronous writes . . . . . : 0
Asynchronous pages read . . . . . : 0

Command ==> -----
F1=Help        F2=Split      F3=Exit       F5=Auto
F6=History     F9=Swap       F12=Cancel    F16=Look
F17=Collect    F22=Purge

```

Figure 52. Buffer Pool Detail window (Thread Activity)

Note: For enhanced system performance, ensure that buffer pools are large enough to store frequently used data in virtual storage, which can reduce the number of I/O operations necessary.

The following list describes some of the important fields that are shown in this window:

Buffer pool hit ratio (%)

The total number of Getpage operations, minus the number of pages read from a hard disk drive (both synchronously and using Prefetch), divided by the total number of Getpage operations, multiplied by 100.

Getpage requests

Number of Getpage requests.

Buffer updates

Number of buffer updates. A nonzero value indicates either SQL INSERT, UPDATE, DELETE activity, merge scan join, and/or activity on the workfiles because of internal sort.

Sequential prefetch requests

Number of times Sequential Prefetch reads were requested. Table space scans and nonmatching index scans generally use Sequential Prefetch.

List prefetch requests

Number of times List Prefetch reads were requested. List Prefetch is always used to access data in multiple index access, and to access data from the inner table during a hybrid join. List Prefetch is usually employed with a single index when the index has a cluster ratio lower than 80%. List Prefetch is sometimes used on indexes with a high cluster ratio if the amount of data estimated to be accessed is too small to make Sequential Prefetch efficient, but large enough that more than one synchronous Read is needed.

Dynamic prefetch requests

Number of times Dynamic Prefetch reads were requested. Dynamic Prefetch is typically used for a SELECT or UPDATE that is run repeatedly, accessing the index for each access.

Synchronous read I/O

Number of synchronous Read I/O operations.

Synchronous writes

Total number of immediate Writes for a page. Although an immediate Write should be rare, a small nonzero value is always expected. A large value indicates that the system needs tuning.

SQL Statement and Program window

Use the SQL Statement and Package window to view information about the current SQL statement being executed or the last SQL statement that was executed by the thread.

To display this window, select SQL Statement from the Thread Detail panel. One of two possible windows is displayed depending on whether the thread is using a package or a DBRM. Only the SQL Statement and Package window is shown here in this section.

Some fields can have values that are longer than the space available to show them in this panel. When this happens, the last character in the field is replaced with an asterisk (*) to indicate that the reported value is truncated.

```

DGOMTWCS                SQL Statement and Program

_ SQL Statement : SELECT * FROM SYSIBM.SYSTABLES WHERE CREATOR='POD'
More: +
Location . . . . . : PM01D711
Collection ID . . . . . : DSNESPCS
Program name . . . . . : DSNESM68
Nested activity name . . . . . : N/P
Program type . . . . . : Package
Consistency token . . . . . : X'149EEA901A79FE48'
Version
N/P
Statement type . . . . . : CLOSE
Statement number . . . . . : 0
Current SQL ID . . . . . : POD
Bind type . . . . . : Dynamic
Cached dynamic SQL identifier . . . . . : N/A
Thread status . . . . . : In DB2
Database name . . . . . : N/P
Page set name . . . . . : N/P
Page number . . . . . : N/P
Elapsed time . . . . . : N/P
CPU time . . . . . : N/P
_ Used Buffer Pools
  Getpages . . . . . : N/P
  Synch read I/O . . . . . : N/P

Command ==> -----
F1=Help      F2=Split    F3=Exit     F5=Auto     F6=History
F7=Up       F8=Down    F9=Swap    F12=Cancel  F16=Look
F17=Collect F18=Explain F22=Purge

```

Figure 53. SQL Statement and Program window

Db2 trace class 9 must be active to show information for the following fields:

- Database name
- Page set name
- Page number
- Elapsed time
- CPU time
- Getpages
- Synch Read I/O

If class 9 is not active N/P is shown.

Use the selection fields to view the complete SQL statement text or information about the buffer pools used during the execution of the query.

SQL Statement Text window

The SQL statement is displayed regardless of whether the agent is currently executing in Db2.

```
DGOMTWC2                SQL Statement                Row 1 to 6 of 6

Program name . . . . . : DSNESM68
SQL Statement
SELECT * FROM SYSIBM.SYSTABLES WHERE CREATOR='POD' OR CREATOR=
'JHS' OR CREATOR='REI' OR CREATOR='SYSADM' OR CREATOR='XRK' OR
CREATOR='CDL' OR CREATOR='DB3704' OR DBNAME='DSNDB01' OR DBNAME=
'DSNDB04' OR DBNAME='DSNDB06' OR DBNAME='DSNRLST' OR DBNAME=
'DSNRGFDB' OR DBNAME='DGODB01' OR DBNAME='REIDB' OR DBNAME=
'JHSTEST' OR DBNAME='DSNATPDB' ORDER BY CREATOR,DBID,OBID DESC
***** Bottom of data *****

Command ==>
F1=Help      F2=Split    F3=Exit     F5=Auto     F6=History  F7=Up
F8=Down      F9=Swap     F12=Cancel  F16=Look    F17=Collect F18=Explain
F22=Purge
```

Figure 54. SQL Statement Text window

The SQL statement is displayed only if you have MONITOR2 or SYSADM privilege. If the SQL statement text is long, you can use the scrolling keys F7 (Up) and F8 (Down) to browse the text.

Note: The SQL statement text can be truncated, depending on the size of the statement and the Db2 version. If the agent is processing an SQL CALL statement, the name of the stored procedure is shown in the Stored procedure field.

You can examine the access paths and processing methods chosen by Db2 for the SQL statement shown in this window. To do this, press F18 (Explain) or type EXPLAIN and press Enter on the command line. See [“Monitoring the access path with Explain” on page 130](#) for more information.

Used Buffer Pools window

This window shows details of the buffer pools used for the execution of the SQL statement. For each buffer pool, the number of Getpage operations and the number of synchronous Read I/O operations is shown.

```
DGOMTWC3                Used Buffer Pools                Row 1 to 2 of 2

Buffer pool name  Getpage requests  Synchronous read I/O requests
BP0                17                0
TOTAL              17                0
***** Bottom of data *****

Command ==>
F1=Help      F2=Split    F3=Exit     F5=Auto     F6=History
F7=Up        F8=Down     F9=Swap     F12=Cancel  F16=Look
F17=Collect  F18=Explain F22=Purge
```

Figure 55. Used Buffer Pools window

Distributed Data window

Use the Distributed Data window to view a list of serving locations that are communicating with the thread. If many locations are listed, you can use the scrolling keys F7 (Up) and F8 (Down) to browse the list.

To display this window, select **Distributed Data** from the Thread Detail panel.

Some fields can have values that are longer than the space available to show them in this panel. When this happens, the last character in the field is replaced with an asterisk (*) to indicate that the reported value is truncated.

```
DGOMTWDD          Distributed Data

For additional details, type any character next to location, then
press Enter.

      Location          Messages          Messages          Requester
      DSNAPC0          Sent          Received          Elapsed
-   DSNAPC0              66              66              7.5908
-   DSNAPC9          12345          12345          6.2222
-- End of Distributed Data --

Command ==> -----
F1=Help      F2=Split      F3=Exit      F5=Auto      F6=History
F7=Up        F8=Down       F9=Swap      F12=Cancel   F16=Look
F17=Collect  F22=Purge
```

Figure 56. Distributed Data window (Thread Activity)

The Distributed Data Facility (DDF) enables an application process connected to one RDB (Relational Database) subsystem to access data residing on other RDB subsystems.

From the Distributed Data window and its lower level windows, you can examine any serving location communicating with the thread, and view any conversations sent between the thread and that serving location in detail. Select any serving location listed in this window to display the Distributed Location Detail window for further examination.

The combination of the Buffer Manager Activity window, SQL Statement and Package/DBRM window, and Distributed Data window can provide a picture of where allied-distributed thread time is spent.

Note: This window does not apply to allied threads.

Distributed Location Detail window

Use the Distributed Location Detail window to view information about the serving location selected from the Distributed Data window. This window displays a list of conversations between the thread and this serving location. If many conversations are listed, you can use the scrolling keys F7 (Up) and F8 (Down) to browse the list.

To display this window, select any serving location listed in the Distributed Data window.

```

DGOMTWDL          Distributed Location Detail          ROW 1 TO 2 OF 2

For additional details, place any character next to conversation, then
press Enter.

Remote Location . . . . . : DSNAPC0
Product ID . . . . . : DB2
Product Version . . . . . : V10 R1 M0
Requester elapsed . . . . . : 7.5908
Messages Sent . . . . . : 66 Remote Elapsed . . . . . : 3.4373
Messages Received . . . . . : 66 Remote CPU . . . . . : 0.0731

----- Conversation -----
State      Type      Time of
SEND      APPL-DIR  last message
- ALLOC    SYST-DIR  03:27:51.15
- End of Distributed Data --
                                02:37:52.12

Command ==> -----
F1=Help   F2=Split   F3=Exit   F5=Auto   F6=History F7=Up
F8=Down   F9=Swap    F12=Cancel F16=Look  F17=Collect F22=Purge

```

Figure 57. Distributed Location Detail window

From this window you can select any conversation listed to display the Distributed Conversation Detail window, where the conversation can be examined in greater detail.

The following list describes some of the important fields that are shown in this window:

Requester elapsed

This field shows the elapsed time spent at the requester between the sending of the SQL statement and the receipt of the answer from the server. This includes the processing time in Db2, VTAM, and the network.

If this value is large, it could indicate block fetch might not have been used.

Messages Received

This field shows the count of the messages the requester location received from the server location.

More messages might be sent from the server location than are received by the requester location because of the manner in which distributed SQL statements are processed internally.

Remote Elapsed

This field shows the elapsed time spent at the server between the actual receipt of the SQL statement and until the answer is sent to VTAM.

This is not applicable to the Distributed Relational Database Architecture (DRDA).

Comparison of this time with elapsed time (class 2) reveals how much time is spent by the allied distributed thread in remote processing.

Remote CPU

This field shows the CPU time spent at the server from the actual receipt of the SQL statement until the answer is sent to VTAM.

This is not applicable to DRDA.

Distributed Conversation Detail window

Use the Distributed Conversation Detail window to examine the conversation selected from the Distributed Location Detail window. This window displays information about just one of the conversations sent between the monitored thread and the serving location selected from the Distributed Data window. To display this window, select any conversation listed in the Distributed Location Detail window.

```

DGOMTWDC          Distributed Conversation Detail

State . . . . . : SEND
Conversation active flag . . . . . : SUSPENDED IN DB2
Type . . . . . : SYST-DIR
Time of last message . . . . . : 03:27:51.15
Conversation ID . . . . . : X'7F6B9398'

Connection ID . . . . . : X'0073F492F7A184B8'
Network connection type . . . . . : TCP/IP

Command ==> -----
F1=Help   F2=Split   F3=Exit   F5=Auto   F6=History
F9=Swap   F12=Cancel  F16=Look  F17=Collect F22=Purge

```

Figure 58. Distributed Conversation Detail window

The following list describes some of the important fields that are shown in this window:

Conversation active flag

This field indicates either:

- Db2 has transferred control of the thread to the network on this conversation.
- The agent is suspended in Db2 and is waiting for notification from the network that the event is completed (asynchronous requests).
- None of the above.

Connection ID

This 64-bit string uniquely identifies the connection on which the conversation is executing.

For VTAM connections, this is the VTAM-defined session instance identifier of the session on which the conversation is executing.

For TPC/IP connections, this is the 32-bit IP address of the remote site, followed by DB2's 16-bit TCP/IP port number and the remote site's 16-bit TCP/IP port number.

Network connection type

This field indicates which type of network connection is used, TCP/IP or VTAM.

IFI (Class 5) and Data Capture window

Use the IFI (Class 5) and Data Capture window to view the number of IFI calls made, the CPU time spent processing these calls, and to examine statistics on data capture activity for the thread.

To display this window, select IFI (Class 5) and Data Capture from the Thread Detail panel.

```

DGOMTWDC          IFI (Class 5) and Data Capture

Elapsed time . . . . . : 11.3441
TCB time . . . . . : 7.8120
Describe time . . . . . : 3.9182
Log extraction time . . . . . : 1.2334

IFI calls . . . . . : 3
Log reads performed . . . . . : 1
Log records captured . . . . . : 15
Log records returned . . . . . : 11
Data rows returned . . . . . : 79
Data descriptions returned . . . . . : 2
Describes performed . . . . . : 2
Tables returned . . . . . : 2

Command ==> -----
F1=Help   F2=Split   F3=Exit   F5=Auto
F6=History F9=Swap   F12=Cancel F16=Look
F17=Collect F22=Purge

```

Figure 59. IFI (Class 5) and Data Capture window

Query Parallelism Data window

Use the Query Parallelism Data window to view information about the number of parallel groups executed for the thread and to find out whether the type or degree of parallelism was changed at run time.

To display this window, select Query Parallelism Data from the Thread Detail panel.

```
DGOMTWQP          Query Parallelism Data
Maximum Degree of Parallelism . . . . . :      5
Parallel Groups Executed . . . . . :      1
Number of Parallel Groups executed with
Planned Parallel Degree . . . . . :      1
Reduced Parallel Degree
No buffer . . . . . :      0
One DB2
COORDINATOR Parm = NO . . . . . :      0
Isolation Level . . . . . :      0
Fall back to sequential mode
Cursor . . . . . :      0
No ESA . . . . . :      0
No buffer . . . . . :      0
MVS/ESA Enclave Services. . . . . :      0
Member skipped (%) . . . . . :      0
Parallelism Disabled by RLF . . . . . :      NO
Command ==>
-----
F1=Help      F2=Split    F3=Exit     F5=Auto     F6=History
F9=Swap      F12=Cancel  F16=Look    F17=Collect F22=Purge
```

Figure 60. Query Parallelism Data window (Thread Activity)

The main objective of query parallelism is to improve query response times.

By examining the information displayed in this window, you can discover the number of parallel groups that have fallen back to sequential mode and determine the cause.

The following list describes some of the important fields that are shown in this window:

Maximum Degree of Parallelism

Maximum degree of parallelism executed among all parallel groups. This field indicates the extent to which query parallelism applies.

The degree can be set on the BIND and REBIND commands or the SET CURRENT DEGREE statement. The default is set by the CURRENT DEGREE installation parameter. If a query is I/O bound, I/O parallelism can help reduce the response time. If a query is CPU bound, query CP parallelism can reduce the response time. If both conditions apply, the benefits for the query can be very large.

Parallel Groups Executed

Total number of parallel groups that have been executed.

Planned Parallel Degree

Total number of parallel groups that executed to the planned parallel degree. This field is incremented by one for each parallel group that executed with the planned degree of parallelism (as determined by Db2).

Reduced Parallel Degree - No buffer

Total number of parallel groups that processed to a parallel degree less than planned because of a storage shortage or contention on the buffer pool. If this field is not zero, increase the size of the current buffer pool by using the ALTER BUFFERPOOL command, or use the ALTER TABLESPACE statement to assign table spaces accessed by this query to a different buffer pool.

One Db2 COORDINATOR Parm = NO

The total number of parallel groups scheduled for Sysplex query parallelism, but executed on a single Db2 because of the COORDINATOR subsystem value being set to NO. When the statement was bound, the COORDINATOR subsystem value was set to YES. This situation can also occur when a package

or plan is bound on a Db2 subsystem with COORDINATOR=YES, but is run on a Db2 subsystem with COORDINATOR=NO.

One Db2 Isolation Level

The total number of parallel groups scheduled for Sysplex query parallelism, but executed on a single Db2 because of repeatable-read or read-stability isolation.

Cursor

Total number of parallel groups that fall back to sequential operation because of a cursor that can be used for update or delete.

No ESA

Total number of parallel groups that fall back to sequential operation because of a lack of MVS/ESA sort support.

No buffer

Total number of parallel groups which fall back to sequential mode because of storage shortage or contention on the buffer pool.

Member skipped (%)

The percentage of Sysplex parallel groups that were not distributed as planned.

This field indicates situations where a member has insufficient buffers and so the parallelism coordinator has to bypass a Db2 when distributing tasks.

Parallelism Disabled by RLF

This field indicates whether parallelism was disabled by RLF governing for dynamic SQL statements of this thread.

Query Parallelism Considerations

Query parallelism is suited to both *data-intensive* and *complex* queries. A query is *data-intensive* if it has a high ratio of I/O compared to CPU and *complex* if it requires a high use of CPU to resolve complex predicates and functions.

In general queries are suited to query parallelism when the following apply:

- Partitioned table space
- Fast n-way processor
- Adequate buffer space to cater for multiple parallel tasks
- Dedicated environment

Query I/O parallelism works best when there is:

- High ratio of I/O time to CPU time
 - Large record size
 - Very large tables
 - Query which scans many rows but returns few
 - Table space scan rather than index scan

Query CP processing works best when there is:

- High ratio of CPU time to I/O time
 - Complex or many predicates
 - Complex many level subqueries
 - Column and scalar functions
 - Multi-way joins
 - Grouping and ordering clauses
 - Type 2 Index access and tablespace scans

Data Sharing Locking Activity window

Use the Data Sharing Locking Activity window to view information about data sharing locking activity for the monitored thread.

To display this window, select Data Sharing Locking Activity from the Thread Detail panel. This selection is only available if the monitored Db2 subsystem is part of a data sharing group.

```

DGOMTWSL          Data Sharing Locking Activity

Global contention rate (%) . . . . . :      More:  - +
                                           N/C
Lock requests . . . . . :      0
Unlock requests . . . . . :      0
Change requests . . . . . :      0

Lock requests - XES . . . . . :      0
Unlock requests - XES . . . . . :      0
Change requests - XES . . . . . :      0

Suspensions
IRLM global contention . . . . . :      0
XES global contention . . . . . :      0
False contention and conversion . . . . . :      0
False contention . . . . . :      0
Incompatible retained lock. . . . . :      0

Notify messages sent . . . . . :      0

Command ==>
F1=Help      F2=Split      F3=Exit      F5=Auto      F6=History
F7=Up        F8=Down       F9=Swap     F12=Cancel   F16=Look
F17=Collect  F22=Purge
  
```

Figure 61. Data Sharing Locking Activity window

The following list describes some of the important fields that are shown in this window:

Lock requests

The number of lock requests for P-locks or locks that are acquired and owned by the Db2 subsystem. This means that P-locks are not owned by threads. A P-lock can be requested on behalf of the subsystem under a user TCB.

Lock requests - XES

The number of lock requests propagated to XES (L-lock or P-lock) synchronously (under the caller's execution unit). If the request suspends for any reason, this counter is not incremented.

The following fields contain the global lock suspend counts for P-locks or L-locks:

IRLM global contention

The number of suspends because of IRLM global resource contention. IRLM lock states were in conflict.

XES global contention

The number of suspends because of XES global resource contention, but no IRLM global resource contention. XES lock states were in conflict, but the IRLM lock states were not.

Suspensions - False contention and conversion

Summation of false contentions (see below) and sync-to-async heuristic conversions. Conversions are done when XES determines that it is more efficient to drive the request asynchronously to the CF.

False contention

The number of false contentions encountered on this z/OS image. A false contention occurs when different resource names hash to the same entry in the CF lock table. The CF detects contention within the hash entry, and XES uses inter-system messaging to determine that no actual resource contention exists. This counter is maintained on a per-LPAR basis. Therefore this counter will over-report false contentions in cases where multiple members from the same data sharing group run on the same z/OS image. The counter is not present (N/P) if data is unavailable because of errors from the IXLMG service.

Incompatible retained lock

The number of global lock or change requests denied or suspended because of an incompatible retained lock.

Group Buffer Pools Activity window

Use the Group Buffer Pools Activity window to view all group buffer pools used by the thread. If many group buffer pools are listed, you can use the scrolling keys F7 (Up) and F8 (Down) to browse the list.

To display this window, select Group Buffer Pools Activity from the Thread Detail panel. This selection is only available if the monitored Db2 subsystem is part of a data sharing group.

```
DGOMTWGB          Group Buffer Pools Activity          1 TO 4 OF 4

For additional details, type any character next to Group Buffer Pool
ID, then press Enter.

  Group Buffer      ----- Read (XI) -----
  Pool ID          Data Returned      No Data Returned
-  GBP0            15                      0
-  GBP2             6                      0
-  GBP32K7         3                      0
-  TOTAL          24                      0
-- End of Group buffer list --

Command ==> -----
F1=Help      F2=Split      F3=Exit      F5=Auto      F6=History
F7=Up        F8=Down       F9=Swap      F12=Cancel   F16=Look
F17=Collect  F22=Purge
```

Figure 62. Group Buffer Pools Activity window

You can select any group buffer pool ID listed in this window to display the Group Buffer Pool Detail window, where you can view information about read and write activity both to and from that particular group buffer pool, or select Total to view read and write activity on all of the listed group buffer pools combined.

Group Buffer Pool Detail window

Use the Group Buffer Pool Detail window to view information about the group buffer pool selected from the Group Buffer Pools Activity window. These statistics show read and write activity both to and from that buffer pool. If Total was selected from the Group Buffer Pools Activity window, the Group Buffer Pool Detail window shows combined statistics on all group buffer pools used by the thread.

```

DGOMTWGD          Group Buffer Pool Detail

Group Buffer Pool ID . . . . . :      GBP0

Read (Cross invalidation)
  Data returned . . . . . :      15
  No data returned . . . . . :      0

Read (Not Found)
  Data returned . . . . . :      0
  No data returned . . . . . :      0

Read prefetch . . . . . :      N/P

Changed pages written . . . . . :      0
Clean pages written . . . . . :      12
Unregister page . . . . . :      0
Command ===> -----
F1=Help          F2=Split        F3=Exit         F5=Auto
F6=History       F7=Up           F8=Down        F9=Swap
F12=Cancel       F16=Look       F17=Collect    F22=Purge

```

Figure 63. Group Buffer Pool Detail window

The following list describes some of the important fields that are shown in this panel:

Data returned (Cross invalidation)

The number of synchronous coupling facility Read requests caused by the page in the member’s buffer pool that is marked invalid. Data is returned from the group buffer pool.

No data returned (Cross invalidation)

The number of synchronous coupling facility Read requests caused by the page in the member’s buffer pool that is marked invalid. Data is not returned from the group buffer pool but from a hard disk drive.

Data returned (Not Found)

The number of synchronous coupling facility Read requests necessary because the requested page was not found in the buffer pool. Data was returned from the coupling facility.

No data returned (Not Found)

The number of synchronous coupling facility Read requests necessary because the requested page was not found in the buffer pool. Data is not returned from the group buffer pool but from a hard disk drive.

Read prefetch

The number of pages read from the group buffer pool because of Prefetch under the control of the agent.

Changed pages written

The number of changed pages synchronously written from the member’s virtual pool to the group buffer pool.

Clean pages written

The number of clean pages synchronously written from the member’s virtual pool to the group buffer pool.

Unregister page

The number of coupling facility requests to unregister a page.

Stored Procedures window

Use the Stored Procedures window to view the stored procedures activity for the thread being monitored. To display this window, select Stored Procedures from the Thread Detail panel.

```

DGOMTWSP                Stored Procedures

CALL statements executed . . . . . : 0
Procedure abends . . . . . : 0
CALL statement timeouts . . . . . : 0
CALL statements rejected . . . . . : 0

Command ==> -----
F1=Help      F2=Split    F3=Exit     F5=Auto     F6=History
F9=Swap      F12=Cancel  F16=Look   F17=Collect F22=Purge

```

Figure 64. Stored Procedures window

CALL statements executed

Total number of SQL CALL statements that were executed for the current thread.

Procedure abends

The number of times a stored procedure terminated abnormally.

CALL statement timeouts

The number of times an SQL CALL statement timed out while waiting to be scheduled.

CALL statements rejected

The number of times an SQL CALL statement was rejected because of the procedure being in the STOP ACTION(REJECT) state.

Thread Activity commands

The commands in this section apply to Thread Activity panels. Commands are typed on a panel command line. Some commands are assigned to function keys. A list of active function keys is displayed at the bottom of each panel. You can abbreviate commands down to three characters in length. For example, the AUTO command can be abbreviated to AUT.

AUTO command

Use the AUTO command to refresh values displayed in panels without having to press Enter. When you activate auto-display mode, the displayed values are updated periodically, as specified by the AUTO command. You cannot perform any other tasks with your Online Monitor session while auto-display mode is running.

The command syntax is:

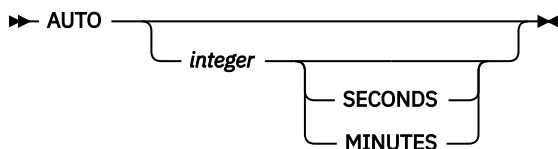

Figure 65. Syntax of the AUTO command

Parameters of the AUTO command

The AUTO command accepts the following parameters:

integer

Optional. Specifies the auto-display interval. The valid ranges are:

- 1 to 7 200 seconds
- 1 to 120 minutes

SECONDS

Optional. Specifies the auto-display unit in seconds. If no unit is specified, the default is seconds. If this parameter is specified, *integer* should also be specified.

MINUTES

Optional. Specifies the auto-display unit in minutes. If this parameter is specified, *integer* should also be specified.

If no parameters are specified, the values in the Auto Display window are used.

Starting Auto Display mode

To start Auto Display mode, type `AUTO` followed by any parameters on the command line and press Enter. You can abbreviate the `AUTO` command to `AUT`, the `SECONDS` to `S`, and the `MINUTES` to `M`.

To stop Auto Display, press the attention key.

Note: While the Online Monitor is executing a Db2 call (IFI or SQL), pressing the attention key might not stop the auto-display mode. An 'A' is displayed every time the key is pressed until attention processing is available again. For example, this is the case when the Online Monitor is issuing SQL statements to resolve names of locked resources.

Examples of the AUTO command

- `AUTO 5` refreshes the panel with updated values every 5 seconds
- `AUTO 1 MIN` refreshes the panel with updated values every minute
- `AUTO 10` refreshes the panel with updated values every 10 seconds
- `AUTO` uses the values specified in the Auto Display window

Examples of the AUTO command

- `AUTO 5` refreshes the panel with updated values every 5 seconds
- `AUTO 1 MIN` refreshes the panel with updated values every minute
- `AUTO 10` refreshes the panel with updated values every 10 seconds
- `AUTO` uses the values specified in the Auto Display window

EXPLAIN command

Use the `EXPLAIN` command to examine the access path methods that were chosen by Db2 for the currently executing SQL statement of a thread.

The `EXPLAIN` command can be issued from the following Thread Activity windows:

- SQL Statement and Package
- SQL Statement and DBRM

The `EXPLAIN` command can also be issued from the Thread Detail panel if it has been tailored to show the SQL statement text.

The command syntax is:

►► EXPLAIN ◀◀

Figure 66. Syntax of the `EXPLAIN` command

Invoking Explain

To examine the access path methods chosen by Db2 for an SQL statement shown in a Thread Activity panel, type EXPLAIN on the command line and press Enter. EXPLAIN can be truncated to a minimum of EXP.

For more information about how to explain an SQL statement, see [“Monitoring the access path with Explain”](#) on page 130.

HISTORY command

Use the HISTORY command to view past data that was previously collected by the data collector. The data is gathered at installation-defined intervals. The date and time in the panels that support history indicate when the data being displayed was collected.

You can only view past data if the data collector is active for the subsystem you are monitoring and if it was started with the parameter HISTORY=YES.

The command syntax is:

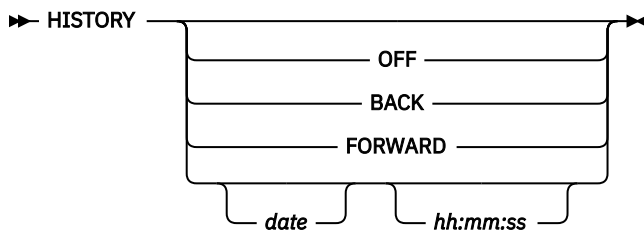

Figure 67. Syntax of the HISTORY command

Parameters of the HISTORY command

The HISTORY command accepts the following parameters:

OFF

Returns the display to the current time.

BACK

Displays data for the previous interval. If no more data is available, data from the earliest available interval is displayed.

FORWARD

Displays information for the next available interval. If no more data is available, data from the current time is displayed and processing continues as if HISTORY is OFF.

date

The date of the required information. If no date is specified, today's date is assumed.

hh:mm:ss

The time of the required information. If no time is specified, the default is the time of the earliest available history record for the specified date. The seconds do not need to be specified.

If no data is available for the specified date and time, the next available record is displayed.

If you do not specify any parameters, the History window is displayed. The current system date and time are the defaults for the History window.

Viewing past data

To view past data, type HISTORY followed by any parameters on the command line and press Enter. HISTORY can be truncated to a minimum of HIS.

RESET command

Use RESET to stop threads from being qualified and sorted in the Thread Summary panel.

The command syntax is:

➤ RESET ➤

Figure 68. Syntax of the RESET command

Resetting thread display

To issue the RESET command, type RESET on the command line of the Thread Summary panel and press Enter. RESET can be truncated to a minimum of RES.

PURGE command

Use the PURGE command to purge a thread that is currently processing in the Db2 subsystem you are monitoring. You need the Db2 privilege to perform CANCEL THREAD.

The PURGE command can be issued from any Thread Activity panel.

The command syntax is:

➤ PURGE ➤

Figure 69. Syntax of the PURGE command

Purging a thread

To purge a thread listed in the Thread Summary panel, type PURGE on the command line, select the listed thread you want to purge, and press Enter. PURGE can be truncated to a minimum of PUR.

To purge the thread being monitored from the Thread Detail panel or any of its lower level windows, type PURGE on the command line and press Enter.

After issuing the PURGE command, the Purge Thread Confirmation window is displayed.

```
DGOMTCPR          Purge Thread Confirmation
Press Enter to purge thread or request CANCEL

Primauth . . : USERT003  Planname . . . . . : DSNESPCS
Program name : DSNESM68  Connection Id . . . . . : DB2CALL

F1=Help      F2=Split      F9=Swap      F12=Cancel
```

Figure 70. Purge Thread Confirmation

To confirm the purge request, press Enter. To cancel the request and not purge the thread, press F12 (Cancel).

If you purge the thread currently being monitored from the Thread Detail panel or any of its lower level windows, you are returned to the Thread Summary panel.

Purging a thread

To purge a thread listed in the Thread Summary panel, type PURGE on the command line, select the listed thread you want to purge, and press Enter. PURGE can be truncated to a minimum of PUR.

To purge the thread being monitored from the Thread Detail panel or any of its lower level windows, type PURGE on the command line and press Enter.

After issuing the PURGE command, the Purge Thread Confirmation window shown in [Figure 71](#) on page 84 is displayed.

```
DGOMTCPR          Purge Thread Confirmation
Press Enter to purge thread or request CANCEL

Primauth . . . : USERT003  Planname . . . . . : DSNEPCPS
Program name : DSNE6M68  Connection Id . . . . . : DB2CALL

F1=Help      F2=Split    F9=Swap     F12=Cancel
```

Figure 71. Purge Thread Confirmation

To confirm the purge request, press Enter. To cancel the request and not purge the thread, press F12 (Cancel).

If you purge the thread currently being monitored from the Thread Detail panel or any of its lower level windows, you are returned to the Thread Summary panel.

QUALIFY command

Use the QUALIFY command to filter the threads shown in the Thread Summary panel. If qualify is active, only threads that match the OMEGAMON XE for Db2 PE identifiers you specified in the Db2 Thread Qualification Parameters window are shown. You can use the QUALIFY command only from the Thread Summary panel.

Thread qualification remains active until deactivated either by a QUALIFY OFF command or the RESET command, even across Online Monitor sessions.

The command syntax is:

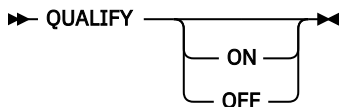

Figure 72. Syntax of the QUALIFY command

Parameters of the QUALIFY command

The QUALIFY command provides the parameters ON and OFF.

ON

Activates the qualify function based on values previously entered in the Db2 Thread Qualification Parameters window.

OFF

Deactivates qualify.

If no parameters are specified, the Db2 Thread Qualification Parameters window is displayed.

Filtering threads

To filter the threads shown in the Thread Summary panel, type QUALIFY followed by any parameters on the Thread Summary panel command line and press Enter. QUALIFY can be truncated to a minimum of QUA.

When qualify is active, the word QUALIFY is displayed in the Thread Summary panel header as shown in the following example:

Figure 73. Thread Summary panel showing qualify active

When the QUALIFY command is issued without parameters, the Db2 Thread Qualification Parameters window is displayed. The content of the window differs depending on the version of Db2 in use.

```

DGOMTWQ5          DB2 Thread Qualification Parameters
Command ==>> -----
Change values as needed:

Primary Authorization ID . . . . . u**I*
Planname . . . . . planx

Package/DBRM
  Location . . . . . *
  Collection ID . . . . . *
  Program name . . . . . *

Connection ID . . . . . *
Correlation ID . . . . . *
Requesting location . . . . . *
Connection type . . . . . *

To include threads, place any nonblank character next to status and type.

Thread Status:          Thread Type:
- I/S                   / Allied
/ Queued                - Allied-distributed
/ In application        - Database access thread (DBAT)
/ In stored procedure
/ In DB2
/ In lock wait
/ In I/O
/ In stored procedure
/ In stored procedure wait
/ In EOT
/ RRS no TCB

F1=Help   F2=Split   F3=Exit   F7=Up     F8=Down   F9=Swap
F12=Cancel F16=Look  F17=Collect
  
```

Figure 74. Db2 Thread Qualification Parameters window

Parameters entered in the Db2 Thread Qualification Parameters window are saved for subsequent sessions. The saved values are used until they are changed.

You can qualify threads by entering any character string in one or more fields in the Db2 Thread Qualification Parameters window. Only threads that match the specified values are displayed in the Thread Summary panel.

You activate qualify from the Db2 Thread Qualification Parameters window by pressing F3 (Exit). To return to the Thread Summary panel without activating qualify, press F12 (Cancel).

OMEGAMON XE for Db2 PE identifiers

The identifier values can be specified in generic form. Place an asterisk (*) in the field to indicate that any value in that character position is valid.

The following rules apply:

- An asterisk in the first character position, followed by blanks, processes all values in that field.
- An asterisk at the end of a character string processes all values beginning with that character string.
- An asterisk in the middle of a character string processes any value in that single character position.

Note: If you leave the value blank for the Plan Name or 1 fields, only threads with blank values for these OMEGAMON XE for Db2 PE identifiers are displayed. If you leave the value blank for any of the other

OMEGAMON XE for Db2 PE identifiers, an asterisk (*) is inserted by default and all values in that field are processed.

Thread status

Place any character beside each status to be included in the threads displayed.

I/S

The thread is in identify or signon state

Queued

The thread is queued

In Application

Processing is occurring within the application

In Application Stored Procedure

The thread is running a stored procedure application

In Db2

The thread is currently processing within Db2

In Lock Wait

The thread is currently suspended waiting for a lock

In I/O

The thread is currently in input or output status

In Db2 Stored Procedure

The thread is running a stored procedure within Db2

In Db2 Stored Procedure Wait

The thread is waiting for a stored procedure to be scheduled within Db2

In EOT

The thread is currently in end-of-task processing.

Thread type

Place any character beside each type of thread to be included in the Thread Summary panel.

Allied

The thread is only doing local processing.

Allied-Distributed

The thread is involved in distributed activity and is requesting data from a remote system.

Database Access Thread (DBAT)

The thread is doing work locally on behalf of an allied-distributed or DBAT-distributed thread created at another site.

Example with the Db2 Thread Qualification Parameters window

This section describes the effects of various parameters entered in the Db2 Thread Qualification Parameters window.

The Db2 Thread Qualification Parameters window is shown in [Figure 74 on page 85](#).

Primary Authorization IDU**R*

This line of the window specifies that only threads with the following authorization IDs are shown:

- Beginning with U
- With any characters in positions 2 and 3
- With an R in position 4
- With any characters in positions 5 through 8

PlanamePLANX

This line of the window specifies that only threads with the Db2 plan name PLANX are shown.

Package/DBRM
Connection ID
Correlation ID
Requesting location
Connection Type

These lines specify that all threads meeting the previous specifications are displayed, regardless of connection ID, correlation ID, requesting location, connection type, or package details.

Note: The 1 field applies to the requesting location for distributed threads, and applies to the local location for allied threads.

Thread Status

The thread status field selections specify that all threads meeting the previous specifications are displayed, except those in I/S status.

Thread Type

The thread type field selections specify that only allied threads meeting the previous specifications are displayed.

SORT command

Use the SORT command to specify the order in which threads are listed in the Thread Summary panel. The threads can be sorted by one or more OMEGAMON XE for Db2 PE identifiers. You can use this command only from the Thread Summary panel.

The command syntax is:

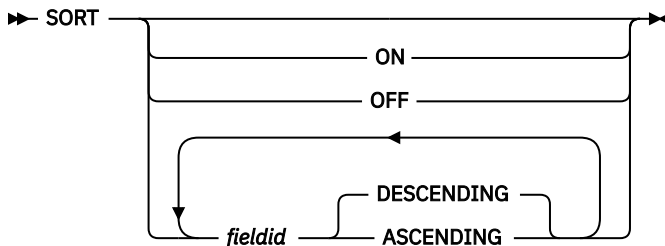

Figure 75. Syntax of the SORT command

Parameters of the SORT command

The SORT command provides the parameters ON, OFF, DESCENDING, and ASCENDING.

ON

Activates sort.

Values previously specified in the Db2 Thread Sort Specification window are used.

OFF

Deactivates sort.

fieldid

Identifies a field used for sorting threads and activates sort. You can specify multiple fields. The threads are sorted by the order of the specified fields.

DESCENDING

Specifies that the threads are to be sorted in descending sequence. This parameter can be abbreviated to D. This is the default.

ASCENDING

Specifies that the threads are to be sorted in ascending sequence. This parameter can be abbreviated to A.

Note:

1. If only one field is specified in a SORT command, you do not need to specify the sequence. The sequence is descending by default.
2. If multiple fields are specified, the sequence (ascending or descending) needs to be specified for each field except the last one.
3. All parameters specified in the command are separated by a single space.

The following table lists all fields that you can use with the SORT command. The field identifiers can be truncated. Uppercase letters indicate the shortest valid abbreviation for each field identifier.

Field	Field ID
Primary Authorization ID	PRImauth
Plan Name	PLAnname
Package/DBRM Program name	PROgram
Package Collection ID	COLlection
Correlation ID	CORrelation
Connection ID	CONNect
Connection Type	CONNType
Thread Status	Status
Request Count	REQUests
Requesting Location	REQLoc
Class 1 elapsed time	C1Elapsed
Class 1 CPU time	C1Cpu
Class 2 elapsed time	C2Elapsed
Class 2 CPU time	C2Cpu
Class 3 time	C3Elapsed

Sorting threads

To sort the threads shown in the Thread Summary panel, type SORT (or one of its abbreviations) followed by any parameters on the command line of the Thread Summary panel and press Enter.

When sort is active, the word SORT is displayed in the Thread Summary panel header as shown in the following example:

```

DGOMTPLS 13:49          Thread Summary          SORT          ROW 1 TO 1 OF 1
PM01DLOC          DSN1 V10  GROUP001 MEMBER01

```

Figure 76. Thread Summary panel showing sort active

If sort is issued without any parameters, the Db2 Thread Sort Specification window is displayed. Parameters entered in this window are saved for subsequent sessions.

Use the Db2 Thread Sort Specification window to specify a thread summary SORT profile. To activate sort from the Db2 Thread Sort Specification window, press F3 (Exit). To return to the Thread Summary panel without activating sort, press F12 (Cancel).

Example 1 of the SORT command

In this example of the Db2 Thread Sort Specification window, the threads are sorted first by Connection type in ascending sequence, and next by Thread status in descending sequence.

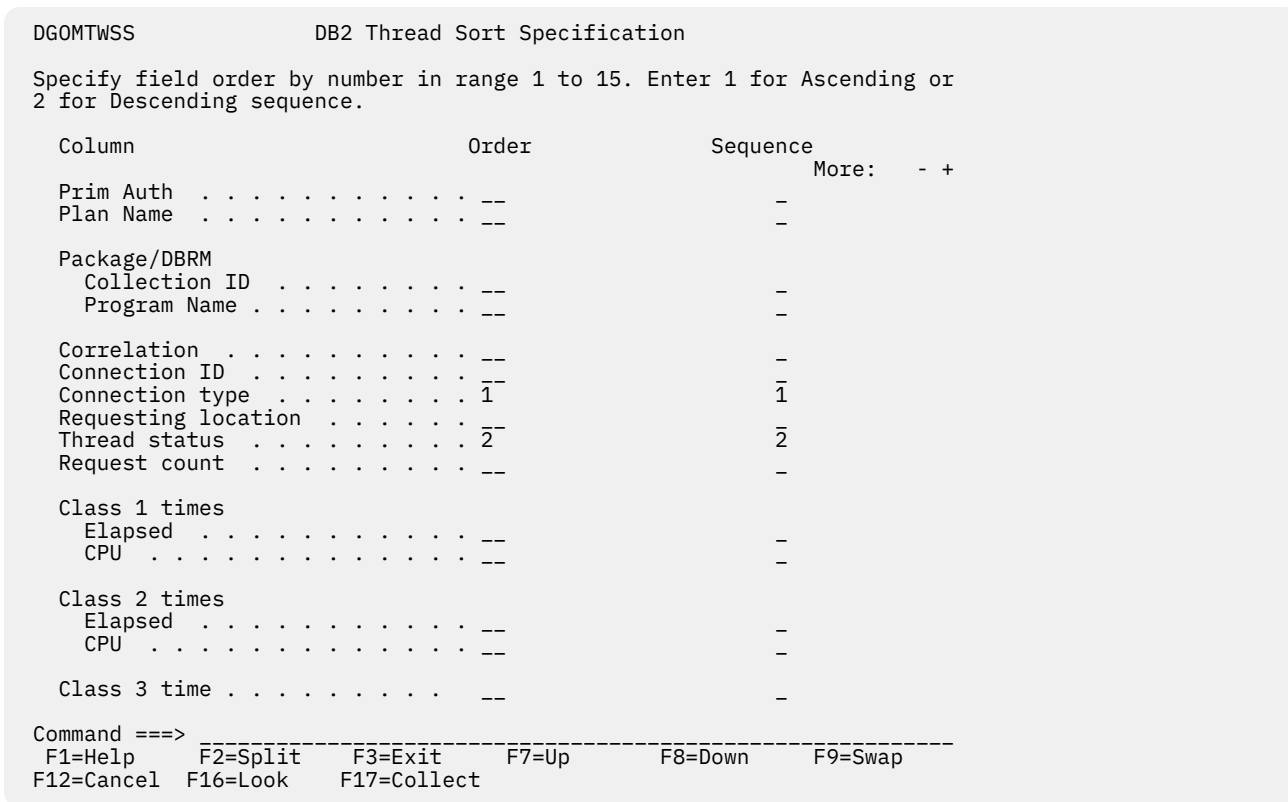

Figure 77. Db2 Thread Sort Specification window

Example 2 of the SORT command

This example shows a SORT command that specifies to sort the threads by different items and the items in different sorting sequences.

Command ==> SORT PRI A C1E D S

This command specifies the following:

1. The threads are sorted first by primary authorization ID in ascending sequence.
2. The threads are ordered next by class 1 elapsed time in descending sequence.
3. The threads are sorted next by thread status. The sequence is descending by default.

Viewing Db2 statistics

The Online Monitor statistics panels provide an overview of Db2 system activity. Use these panels to view important ratios and Db2 statistics values.

Note: This function is not supported for Db2 11.

Most Db2 statistics field values accumulate while the Db2 subsystem is active. When Db2 is started, the accumulation process begins and continues until the Db2 subsystem is stopped. There are, however, certain fields that are not cumulative. Some are reported as "snapshot" values, and some are reported as "high water mark" values. A snapshot value is a current value, and is updated each time the statistics values are displayed. A high water mark is a maximum value since startup, and is updated each time the statistics values are displayed.

Fields that are not snapshot or high water mark values are known as delta values. They are derived differently for each of the statistics processing modes. They are calculated by the statistics display. For further details, see [“Interval processing mode” on page 91](#) and [“Delta processing mode” on page 91](#).

List of all Statistics panels

The following list covers all Statistics panels that are described in this section:

- [Db2 Statistics Detail panel](#)
- [EDM Pool window](#)
- [Buffer Manager window](#)
- [Buffer Pool window](#)
- [Locking Activity window \(Statistics\)](#)
- [Open/Close Management window](#)
- [Bind Processing window](#)
- [Plan and Package Allocation window](#)
- [Log Manager window](#)
- [Subsystem Service window](#)
- [SQL Activity window \(Statistics\)](#)
- [Query Parallelism Data window \(Statistics\)](#)
- [RID List Processing window \(Statistics\)](#)
- [Distributed Data window \(Statistics\)](#)
- [Remote Location window](#)
- [Statistics CPU Times and Other Data window](#)
- [Db2 Commands window](#)
- [Db2 Instrumentation window](#)
- [Db2 IFC Destinations window](#)
- [Data Capture window](#)
- [Data Sharing Locking Activity window](#)
- [Group Buffer Pools Activity window](#)
- [Group Buffer Pool Detail window](#)
- [Global Group Buffer Pool Statistics window](#)
- [Global GBP Statistics Detail window](#)
- [Stored Procedures window](#)

Statistics processing modes

There are three different modes of display available for the statistics panels: regular mode, interval mode, and delta mode. Interval mode and delta mode determine the time over which delta values are accumulated. Deltas are not calculated in regular mode. Whenever option 2 (Display Statistics) is selected from the Online Monitor Main Menu, regular mode is activated.

To operate in either interval mode or delta mode, enter an INTERVAL or DELTA command on the command line of any statistics panel.

Statistics values are updated when:

- You press Enter in any statistics panel, with the command line blank and no windows selected.
- You issue an INTERVAL, DELTA, or RESET command.
- You activate auto-display mode, which updates values automatically at a time interval that you specify.

Note: The auto-display function needs to be disabled before an INTERVAL, DELTA, or RESET command is issued. To stop auto-display, press the Attention key. The auto-display function can be activated again after the processing mode command is issued.

Regular processing mode

This is the default mode of operation whenever you select option 2 (Display Statistics) from the Online Monitor Main Menu. In this mode, the delta values displayed are accumulated since Db2 startup. No calculations are performed on the statistics values in this mode. You must be in interval or delta processing mode to use display exception processing. Use the RESET command to return to regular mode.

Interval processing mode

To activate interval processing mode, type INTERVAL on the command line of any statistics panel and press Enter. In interval processing mode, the delta values displayed are accumulated since the last time the INTERVAL command was entered on the command line. When interval mode is activated while viewing past data, the values are accumulated between the history time shown when the INTERVAL command was issued and the current history time.

Use interval mode to isolate Db2 statistics activity beginning at a specified time. Interval processing can help indicate the existence of a problem when running with exception processing. When you select interval processing mode, all statistics field values (except high water mark and snapshot fields) are cleared and begin the accumulation process from the start. The first values displayed after the INTERVAL command is issued represent the values from the newly-established base point to the first statistics record pair (IFCID 1 and IFCID 2) encountered after the INTERVAL command. Thereafter, the values are updated each time you press Enter. The auto-display function can be activated with interval processing mode. Statistics values are then updated automatically at the time interval that you specified. A new base point can be established by repeating the INTERVAL command.

If interval processing mode is activated, all statistics panels operate in interval mode. The time elapsed since the base point was established is displayed on the line under the heading of each statistics panel, as shown in the following figure:

```
DGOMSPSM 12:07          DB2 Statistics Detail          PM01DL0C DSN1 V10
                        GROUP001 MEMBER01
                        INTERVAL 40.088
For details, type any character next to heading, then press Enter.
```

Figure 78. Db2 Statistics Detail panel showing interval active

Interval mode remains active until either it is turned off or you return to the main menu. You can deactivate interval mode using the RESET or DELTA command from any statistics panel. Use the RESET command to return to regular mode.

Delta processing mode

To activate delta processing mode, type DELTA on the command line of any statistics panel and press Enter. In delta processing mode, the values are accumulated between the last two times you pressed Enter. When delta mode is activated while viewing past data, delta processing uses the currently shown history time and the next available history snapshot to accumulate the values.

Use delta processing to isolate Db2 statistics activity that occurs between two specified points in time. Delta mode operates similarly to the Batch statistics trace. When you initiate delta mode, Db2 statistics field values are reported in time slices. A new base point is established each time the displayed values are updated. With the exception of the high water mark and snapshot fields mentioned previously, all statistics field values reflect the activity since the previous display update.

After delta is activated, all statistics panels operate in delta mode. The elapsed time since the last DELTA command was entered or since the last time Enter was pressed is displayed on the line under the heading as shown in the following figure:

For details, type any character next to heading, then press

DELTA 9.182
Enter.*Figure 79. Db2 Statistics Detail panel showing delta active*

Delta mode remains active until you deactivate it or you return to the main menu. You can turn off delta mode using the RESET or INTERVAL command from any statistics panel.

Snapshot fields

The table in this section lists a selection of snapshot fields and their corresponding Statistics panels.

<i>Table 7. Snapshot fields</i>		
Statistics panel	Field	Panel ID
Db2 Statistics Detail	EDM Pool pages in use (%)	DGOMSPSM
EDM Pool	EDM Pool pages in use (%) Pages in EDM Pool Free pages in free chain Pages used for CT Pages used for SKCT Pages used for PT Pages used for SKPT Pages used for DBD	DGOMSWEP
Buffer Pool - General	Current active buffers Buffers allocated for virtual buffer pool	DGOMSWBR
Buffer Pool - Work File Operations	Maximum concurrent workfiles	DGOMSWBV
Open/Close Management	Open data sets - Current Open data sets - With CLOSE(NO) Open data sets - Not in use Data sets on Deferred Close queue - Current	DGOMSOC2 DGOMSWOC
Query Parallelism Data	Maximum Degree of Parallelism	DGOMSWQP
RID List Processing	RID blocks allocated - Current	DGOMSWRP
Distributed Data	Inactive DBATs - Current Active DBATs - Current	DGOMSWDD

High water mark fields

The table in this section lists high water mark fields and their corresponding Statistics panels.

Table 8. High water mark fields

Statistics panel	Field	Panel ID
Db2 Statistics Detail	Open data sets - High Water Mark	DGOMSPSM
Buffer Pool - Query Parallelism	Concurrent streams - high water mark	DGOMSWBU
Open/Close Management	Open data sets - HWM Data sets on Deferred Close queue - Maximum	DGOMSWOC
RID List Processing	RID blocks allocated - Maximum	DGOMSWRP
Distributed Data	Inactive DBATs - HWM Active DBATs - HWM Total DBATs - HWM	DGOMSWDD

Statistics panel overview

The Db2 Statistics Detail panel shows a summary of key statistics values. From this panel, you can reach windows that provide statistics data in greater detail.

Moving between statistics panels does not cause the values shown to be updated. Data displayed in the current panel is refreshed whenever you press Enter *without* selecting a window to be displayed or executing a command.

Db2 Statistics Detail panel

Use the Db2 Statistics Detail panel to view key Db2 performance data and percentages and important Db2 thresholds. The Db2 Statistics Detail panel should be used as a regular check of the Db2 performance.

To display the Db2 Statistics Detail panel, select option 2 (Display Statistics) from the Online Monitor Main Menu.

Note: The Db2 Statistics Detail panel displayed at your site might have been tailored by your installation and consequently might not necessarily match the panel example shown in this information.

```

DGOMSPSM 12:58          DB2 Statistics Detail          PM01DLOC DSN1 V10
                        GROUP001 MEMBER01
                        INTERVAL 12:43.051
For details, type any character next to heading, then press Enter
More:  - +
- EDM Pool
  EDM Pool full . . . . . : 0
  EDM Pool pages in use (%) . . . . . : 1.6
  CT requests/CT not in EDM pool . . . . . : 7.4
  PT requests/PT not in EDM pool . . . . . : 1.8
  DBD requests/DBD not in EDM pool . . . . . : 27.4
- Buffer Manager
  Synchronous Reads . . . . . : 10.3
  Deferred write threshold reached . . . . . : 0
  DM critical threshold reached . . . . . : 0
- Locking Activity
  Suspensions - all . . . . . : 6089
  Deadlocks . . . . . : 0
  Timeouts . . . . . : 0
  Lock escalations - all . . . . . : 0
- Open/Close Management
  Open data sets - High Water Mark . . . . . : 58
- Bind Processing
- Plan/Package Allocation, Authorization Management
- Log Manager
  Reads satisfied - Output Buffer . . . . . : 39
  Reads satisfied - Active Log . . . . . : 397
  Reads satisfied - Archive Log . . . . . : 0
  Write-no-wait . . . . . : 1677
  Unavailable output log buffers . . . . . : 0
- Subsystem Service
  Queued at create thread . . . . . : 0
  System event checkpoints . . . . . : 2
- SQL Activity
- PREPARE Detail
  Prepare . . . . . : 10
- Query Parallelism Data
- RID List Processing
- Distributed Data
- CPU Times and Other Data
- Data Sharing Locking Activity
- Group Buffer Pool Activity
- Global Group Buffer Pool Statistics
- Stored Procedures

Command ==> -----
F1=Help    F2=Split  F3=Exit   F5=Auto   F6=History F7=Up
F8=Down    F9=Swap   F10=Delta F11=Interval F12=Cancel F16=Look
F17=Collect

```

Figure 80. Db2 Statistics Detail panel

From this panel, you can display windows that show statistics about various aspects of the system. Type any character in the selection field next to the corresponding heading and press Enter. Multiple windows can be selected simultaneously.

If you have enabled display exception processing, all fields in exception status are shown in reverse video, and the color indicates the level of the exception. *Warning* level exceptions are highlighted in yellow, while *problem* level exceptions are highlighted in red. Selection fields in this panel are shown in reverse video when their next level windows contain fields in exception status.

The following list describes some of the important fields that are shown in this panel:

EDM Pool pages in use (%)

The percentage of pages in the EDM pool that have been used or are currently in use (snapshot value). This means, it shows the number of nonstealable pages.

During peak periods, the value in this field should be between 80 and 100 percent. Because stealable pages are not represented here, a value close to 100 percent does not necessarily indicate an EDM pool constraint. As the value approaches 100, examine the efficiency ratios to verify that acceptable levels are met. If the EDM pool is too small, it causes increased I/O activity in database DSNDB01, table spaces DBD01 and SCT02.

Note: The EDM pool use varies across the day. It is not only the pages that are in use, but also the pages that are not in use, waiting to avoid I/O, that are important for performance.

Synchronous Reads

Number of synchronous read I/O operations performed by sequential and random requests.

Deadlocks

Number of times lock suspensions ultimately resulted in a deadlock. This happens when two or more application processes each hold locks on resources that the others need, without which they cannot proceed. Deadlocks result principally from an application design problem. Ensure that all applications accessing the same tables access them in the same order. Deadlocks can also occur through index page splits if there is high insert activity. In this case, it is suggested to set SUBPAGES to 1 for the index.

Timeouts

Number of times lock suspensions ultimately resulted in a timeout. This happens when a requester for a lock on a resource has waited longer than the installation-specified RESOURCE TIMEOUT limit in the Db2 Install panel DSNTIPI.

Reads satisfied - Archive Log

Number of times Db2 needed to read log records, and had to go to the archive log for the records. The value for this should ideally be zero.

System event checkpoints

The value in this field indicates the frequency of Db2 checkpoints. For example, if the statistics interval is 30 minutes and the value of this field is 15, Db2 is taking checkpoints every 2 minutes.

PREPARE Detail

Select this field to display the PREPARE Detail panel.

Prepare

The number of prepares. It reflects the number of real PREPARE commands received by Db2. If the PREPARE is satisfied by getting a copy from the cache rather than by the traditional prepare process, the count is incremented. If the prepares are done under control of KEEP DYNAMIC(YES), the count is not incremented.

Db2 Statistics windows

You can access the following windows from the Db2 Statistics Detail panel. To reach a window, type any character in the space beside the heading you want. Multiple windows can be accessed simultaneously. The windows are overlaid on the Db2 Statistics Detail panel. To leave the current window and proceed with the next window, press F3 (Exit). To cancel all windows and return to the Db2 Statistics Detail panel, press F12 (Cancel).

EDM Pool window

Use the EDM Pool window to examine statistics on the efficiency of the EDM buffer pool, and to determine the size of the EDM pool for optimum system performance.

To display this window, select EDM Pool from the Db2 Statistics Detail panel.

```

DGOMSWEP          EDM Pool

                    INTERVAL  3:32.419
                    More:    - +
Requests for CT sections . . . . . : 89
CT section not found in EDM pool . . . . . : 12
CT requests/CT not in EDM pool . . . . . : 7.4

Requests for PT sections . . . . . : 16
PT section not found in EDM pool . . . . . : 9
PT requests/PT not in EDM pool . . . . . : 1.8

Requests for DBD sections . . . . . : 137
DBD section not found in EDM pool . . . . . : 5
DBD requests/DBD not in EDM pool . . . . . : 27.4

EDM Pool full . . . . . : 0
EDM Pool pages in use (%) . . . . . : 1.6

Pages in EDM pool . . . . . : 1425
Free pages in free chain . . . . . : 1402
Pages used for CT . . . . . : 1
Pages used for SKCT . . . . . : 9
Pages used for PT . . . . . : 0
Pages used for SKPT . . . . . : 4
Pages used for DBD . . . . . : 9

Inserts for dynamic cache . . . . . : 91381
Requests for dynamic cache section . . . . . : 117202
Pages used cache . . . . . : 1310
Command ==>
  F1=Help      F2=Split      F3=Exit      F5=Auto
  F6=History   F7=Up         F8=Down      F9=Swap
  F10=Delta    F11=Interval  F12=Cancel   F16=Look
  F17=Collect

```

Figure 81. EDM Pool window

The EDM pool size should be large enough to store the cursor tables (CTs), package tables (PTs), and database descriptors (DBDs) for the most frequently used applications.

The following list describes some of the important fields that are shown in this panel:

EDM Pool pages in use (%)

The percentage of the EDM pool pages that are in use. If this percentage is consistently less than 50%, the EDM pool size is probably too large. The size can be reduced without affecting the efficiency ratios (CT requests/CT not in EDM pool, PT requests/PT not in EDM pool, and DBD requests/DBD not in EDM pool) significantly. However, driving the EDM pool toward 100% usage can cause performance problems.

EDM pool use varies during the day. It is not only the pages that are in use, but also the pages that are not in use, waiting to avoid I/O, that are important for performance.

CT requests/CT not in EDM pool

Ratio of number of requests for CT sections and number of times CT sections were not already in the EDM pool.

PT requests/PT not in EDM pool

Ratio of number of requests for PT sections and number of times PT sections were not already in the EDM pool.

DBD requests/DBD not in EDM pool

Ratio of number of requests for DBDs and number of times DBDs were not already in the EDM pool.

Buffer Manager window

Use the Buffer Manager window to view a list of active buffer pools and to examine synchronous reads and important threshold information.

To display this window, select Buffer Manager from the Db2 Statistics Detail panel.

```

DGOMSWBM                Buffer Manager                ROW 1 TO 4 OF 4
                                INTERVAL 1:59.084
For additional details, type any character next to Buffer Pool ID,
then press Enter.

  Buffer Pool Synchronous  Hit      Deferred Write      DM Critical
  ID                      Read   Ratio  Threshold Reached  Threshold Reached
- BP0                      6    29.3           3                   3
- BP1                      6    41.4           3                   3
- BP2                      6    11.9           3                   3
- BP3                      6     7.0           3                   3
--- End of Buffer Pool List ---

Command ==> -----
F1=Help      F2=Split    F3=Exit     F5=Auto     F6=History
F7=Up        F8=Down    F9=Swap    F10=Delta   F11=Interval
F12=Cancel   F16=Look   F17=Collect

```

Figure 82. Buffer Manager window

The buffer manager is one of the major components involved in Db2 system performance. The buffer manager’s most significant role in performance is to reduce I/O activity, and to perform required I/O in an efficient manner.

Buffer pools should be large enough to store frequently used data in virtual storage to reduce physical I/Os. However, to minimize paging I/O, choose buffer pool sizes that can be backed by real or expanded storage.

Select any active buffer pool listed in the Buffer Manager window to display the Buffer Pool window, where you can view further details about an individual buffer pool. Multiple windows can be accessed simultaneously by selecting multiple fields. The windows are overlaid on the Buffer Manager window. To leave the current window and proceed with the next window, press F3 (Exit). To cancel all windows and return to the Db2 Statistics Detail panel, press F12 (Cancel).

Buffer Pool Management in Db2

Use these buffer pool statistics in conjunction with the system parameters panels. The statistics panels show when various thresholds have been reached or exceeded, the system parameters panels show what the buffer pool settings currently are. You can alter buffer pool settings dynamically using the Db2 ALTER BUFFERPOOL command

Buffer Pool windows

Use the Buffer Pool window to view important statistics about an active buffer pool.

To display the Buffer Pool window, select any active buffer pool listed in the Buffer Manager window.

On the Buffer Pool window, select the required type of information. A further window then displays the requested information. Use the scrolling keys F7 (Up) and F8 (Down) to view the portions of the window not displayed.

```

DGOMSWBY                               Buffer Pool BP1
Command ===> -----

For details, type any character next to heading, then press Enter.

_ General
_ Read Operations
_ Write Operations
_ Query Parallelism
_ Sort/Merge Work File Operations

F1=Help      F3=Exit      F5=Auto      F6=History   F7=Up
F8=Down     F10=Delta    F11=Interval F12=Cancel   F16=Look
F17=Collect

```

Figure 83. Buffer Pool window

Depending on your selection one of the following windows is displayed. Each window is followed by a description of some of the important fields shown in this window.

```

DGOMSWBR                               Buffer Pool BP1
                                         General
Command ===> -----

Virtual buffer pool pages in use (%) . . . . . More: +
Buffer pool hit ratio (%) . . . . . : 0.0
Current active buffers . . . . . : 73.4
Buffer Pool full . . . . . : 0
Successful data set opens . . . . . : 0
DFHSM migrated data sets . . . . . : 35
DFHSM recall timeouts . . . . . : 0

Buffers allocated
  For Virtual buffer pool . . . . . : 50

ALTER BUFFERPOOL expansions and contractions
  For Virtual buffer pool . . . . . : 0
F1=Help      F3=Exit      F5=Auto      F6=History   F7=Up
F8=Down     F10=Delta    F11=Interval F12=Cancel   F16=Look
F17=Collect

```

Figure 84. Buffer Pool – General window

Buffer pool hit ratio (%)

The total number of Getpage operations, minus the number of pages read from a hard disk drive (both synchronously and using Prefetch), divided by the total number of Getpage operations, multiplied by 100.

Current active buffers

Total number of current active (nonstealable) buffers at the moment the statistics were collected. A buffer critical condition is only shown if it occurs at that moment. The buffer pool might be too small if the number of active buffers is greater than the Deferred Write threshold (DWQT) of the buffer pool.

```

DGOMSWBS                               Buffer Pool BP1
                                         Read Operations
Command ===> -----

                                         More:    +
Getpage requests
  Total . . . . . : 103519
  Sequential access only . . . . . : 10883

Synchronous reads
  Total . . . . . : 14720
  Sequential access only . . . . . : 2900

Sequential prefetch
  Requested . . . . . : 1104
  Reads . . . . . : 1087
  Pages read . . . . . : 10895

List prefetch
  Requested . . . . . : 4
  Reads . . . . . : 0
  Pages read . . . . . : 0

Dynamic prefetch
  Requested . . . . . : 242
  Reads . . . . . : 242
  Pages read . . . . . : 1936

Prefetch disabled
  No buffer . . . . . : 12
  No read engine . . . . . : 0

Page-ins required for read I/O . . . . . : 185
F1=Help      F2=Split    F3=Exit      F5=Auto      F6=History
F7=Up        F8=Down     F9=Swap     F10=Delta   F11=Interval
F12=Cancel   F16=Look   F17=Collect

```

Figure 85. Buffer Pool – Read Operations window

Getpage requests - Total

The number of Getpage requests issued by sequential and random requests.

Synchronous reads - Total

The number of synchronous read I/O operations performed by sequential and random requests.

Sequential prefetch - Reads

The number of times Sequential Prefetch reads were performed.

Sequential prefetch - Pages read

Number of pages read because of Sequential Prefetch.

The ratio of Sequential prefetch - Pages read to Sequential prefetch - Reads is between 0 and 32. Normally 32 is the maximum Prefetch quantity for table space scans, whether data or index.

List prefetch - Reads

Number of times List Prefetch reads were performed.

List prefetch - Pages read

Number of pages read because of List Prefetch.

The ratio of List prefetch - Pages read to List prefetch - Reads is between 0 and 32.

Dynamic prefetch - Reads

Number of times Dynamic Prefetch reads were performed.

Dynamic prefetch - Pages read

Number of pages read because of Dynamic Prefetch performed because of sequential detection.

The ratio of Dynamic prefetch - Pages read to Dynamic prefetch - Reads is between 0 and 32.

Prefetch disabled - No buffer

Number of times Sequential Prefetch was disabled because buffers were not available. This is the number of times the Sequential Prefetch threshold was reached. This fixed threshold is experienced if 90% of the pages in the buffer pool are unavailable. This has a significant effect on large and frequent scans that use Sequential Prefetch.

```
DGOMSWBT          Buffer Pool BP1
                  Write Operations
Command ===> -----

Buffer updates . . . . . : 4706
Pages written . . . . . : 2077
Synchronous writes . . . . . : 5
Asynchronous writes . . . . . : 2025
Write engine not available . . . . . : 0

Thresholds reached
Deferred write . . . . . : 0
Vertical deferred write . . . . . : 1742
Data Manager critical . . . . . : 0

Page-ins required for write I/O . . . . . : 0

F1=Help      F2=Split      F3=Exit      F5=Auto      F6=History
F7=Up        F8=Down       F9=Swap     F10=Delta    F11=Interval
F12=Cancel   F16=Look     F17=Collect
```

Figure 86. Buffer Pool – Write Operations window

Buffer updates

Number of times pages were updated in the buffer pool.

Pages written

Number of pages written. This field contains the number of pages in the buffer pool written to a hard disk drive.

Synchronous writes

Total number of immediate Writes for a page.

An immediate Write can occur when:

- Data set is closed
- Db2 Checkpoint is taken
- Immediate Write threshold (97.5% pages in the buffer pool are unavailable), which is a fixed threshold
- a Write engine is not available

Asynchronous writes

Number of asynchronous Write I/O operations performed by media manager to a direct access storage device.

Thresholds reached - Deferred write

Number of times the Deferred Write threshold was reached. This threshold is a percentage of the virtual buffer pool that might be occupied by unavailable pages, including both updated pages and pages in use.

Thresholds reached - Vertical deferred write

Number of times the Vertical Deferred Write threshold was reached. This threshold is expressed as a percentage of the virtual buffer pool that might be occupied by updated pages from a single data set.

When this threshold is reached, Writes are scheduled for that data set.

Thresholds reached - Data manager critical

Number of times the data manager critical threshold was reached. This fixed threshold is experienced if 95% of the pages in the buffer pool are unavailable. This has a significant effect on CPU usage.

```

DGOMSWBU                               Buffer Pool BP1
                                         Query Parallelism
Command ===> -----

Prefetch I/O streams
  Concurrent streams - high water mark . . . . . : 2
  Streams reduced - buffer shortage . . . . . : 0
Parallel query requests . . . . . : 44
Reduced parallel query requests . . . . . : 0
Prefetch quantity reduced to 1/2 . . . . . : 0
Prefetch quantity reduced to 1/4 . . . . . : 0

F1=Help      F2=Split    F3=Exit      F5=Auto      F6=History
F7=Up        F8=Down     F9=Swap     F10=Delta    F11=Interval
F12=Cancel   F16=Look   F17=Collect

```

Figure 87. Buffer Pool – Query Parallelism window

```

DGOMSWBV                               Buffer Pool BP1
                                         Sort/Merge Work File Operations
Command ===> -----

Maximum concurrent work files . . . . . : 0
Requested for all merge passes . . . . . : 0
Not Created - no buffer . . . . . : 0
Prefetch not scheduled - zero quantity . . . . . : 0
Pages marked to destruct . . . . . : 0
Pages not written . . . . . : 0
Merge passes requested . . . . . : 0
Degraded - low buffers . . . . . : 0
Workfile requests rejected - low buffers . . . . . : 0

F1=Help      F2=Split    F3=Exit      F5=Auto      F6=History
F7=Up        F8=Down     F9=Swap     F10=Delta    F11=Interval
F12=Cancel   F16=Look   F17=Collect

```

Figure 88. Buffer Pool – Sort/Merge Work File Operations window

Not created - no buffer

The number of times a workfile could not be created because of insufficient buffer resources during sort processing.

Prefetch not scheduled - zero quantity

The number of workfile Prefetches rejected because of a zero Prefetch quantity.

Degraded - low buffers

The number of times that a merge pass could not be efficiently performed because of a shortage of space in the buffer pool.

Workfile requests rejected - low buffers

The number of workfiles (runs) that were rejected during all merge passes because of shortage of space in the buffer pool.

Locking Activity window

Use the Locking Activity window to view statistics on lock suspensions, timeouts, deadlocks, and lock escalations.

To display this window, select Locking Activity from the Db2 Statistics Detail panel.

```

DGOMSWLK          Locking Activity

                                INTERVAL 12.634
                                More:    - +
Timeouts . . . . . : 0
Deadlocks . . . . . : 0

Lock requests . . . . . : 277897
Unlock requests . . . . . : 84033

Query requests . . . . . : 24763
Change requests . . . . . : 25798
Other requests . . . . . : 3
Suspensions - lock . . . . . : 3
Suspensions - latch . . . . . : 1540
Suspensions - other . . . . . : 24764
Lock escalations - shared . . . . . : 0
Lock escalations - exclusive . . . . . : 0
Claim requests . . . . . : 15149
Unsuccessful claim requests . . . . . : 6
Drain requests . . . . . : 1353
Unsuccessful drain requests . . . . . : 0

Lock and change requests
per lock suspensions . . . . . : 101K

Command ==>
F1=Help      F2=Split    F3=Exit     F5=Auto
F6=History   F7=Up       F8=Down     F9=Swap
F10=Delta    F11=Interval F12=Cancel  F16=Look
F17=Collect

```

Figure 89. Locking Activity window (Statistics)

Application deadlocks and timeouts should be avoided if possible. Unusually high values for these fields indicate the existence of a problem application. Exception events and console messages indicate deadlock participants. Use history to view details of the event surrounding the deadlock. You can use the Locked Resources window in thread activity to investigate thread resources locked or held.

Lock escalation counts greater than zero usually indicate an application process that updates more pages than expected. If this is not the case, examine fields Max page locks per table space and Max locks per user in the Db2 System Parameters panel to determine whether to increase DSNZPARM fields NUMLKTS and NUMLKUS (LOCKS PER TABLE(SPACE) and LOCKS PER USER respectively in the INSTALL Db2 - IRLM PANEL 2 panel DSNTIPJ).

The following list describes some of the important fields that are shown in this panel:

Lock requests

Number of times a lock on a resource was requested.

Suspensions - lock

Number of resource conflicts. A suspension is a wait for a lock and each of these waits can contribute adversely to Db2 performance. The suspension can ultimately result in normal resumption, or, in the case of lock contention, in a timeout or deadlock. The number of lock suspensions is a function of the lock requests. Lock suspensions (or conflicts) can occur on either lock request or change request.

Lock escalations - shared

Count of lock escalations to shared mode. Number of times the LOCKS PER TABLE(SPACE) parameter in the Db2 Install panel DSNTIPJ was exceeded and the table space lock was promoted from a page lock (IS) to a table space lock (S). Escalation can cause unpredictable response times. The lock escalation to shared mode should only happen on an exception basis. For example, a REPEATABLE READ application references most pages in a table.

Lock escalations - exclusive

Count of lock escalations to exclusive mode. Number of times the LOCKS PER TABLE(SPACE) parameter in the Db2 Install panel DSNTIPJ was exceeded and the table space lock was promoted from a page lock (IX) to a table space lock (X). Escalation can cause unpredictable response times. The lock escalation to exclusive mode should only happen on an exception basis. For example, an application updates most pages in a table.

Lock escalations, shared or exclusive, should not be expected in a transaction environment.

Locking Considerations

The following aspects should be considered if concurrency is an issue.

- Consistent data access sequence in applications
- The mix of concurrent processing types (batch and transaction)
- IRLM startup procedure options and Db2 installation options
- DDL LOCKSIZE
- DDL LOCKMAX
- BIND parameters

See [IBM Db2 for z/OS in the IBM Knowledge Center](#) for detailed information.

Open/Close Management window

The Open/Close Management window displays statistics on data set activity and drain requests. Use the Open/Close Management window to determine the number of open data sets, the number of drain requests, the number of page sets available to drain, and the number of successful and failed drains.

To display this window, select Open/Close Management from the Db2 Statistics Detail panel.

```
DGOMSWOC          Open/Close Management
                                     INTERVAL 3:32.419
Open data sets
High water mark . . . . . : 106
Current . . . . . : 105
Not in use, not closed
  High water mark . . . . . : 106
  Current . . . . . : 103
In use . . . . . : 2
Data sets closed - threshold reached . . . . . : 0
Data sets converted from R/W to R/O . . . . . : 1295
Command ==> -----
F1=Help      F2=Split    F3=Exit     F5=Auto
F6=History   F9=Swap     F10=Delta   F11=Interval
F12=Cancel   F16=Look    F17=Collect
```

Figure 90. Open/Close Management window

The following list describes some of the important fields that are shown in this panel:

Open data sets - High water mark

The maximum number of data sets open concurrently (high water mark).

Monitor this field to see whether you are reaching the maximum number of open data sets permissible for your system. The maximum number of open data sets depends on the MVS version, modifications to your system, and various other factors. See [z/OS information in the IBM Knowledge Center](#) for the maximum number of open data sets permissible for your system.

Bind Processing window

Use the Bind Processing window to view statistics on plans successfully bound, attempts to REBIND a plan, automatic binds, and attempts to FREE a plan.

To display this window, select Bind Processing from the Db2 Statistics Detail panel.

```

DGOMSWBI          Bind Processing

                                INTERVAL 9:21.950
                                More:      - +

Bind
Plans bound . . . . . : 6
Plan ADD subcommands . . . . . : 0
Plan REPLACE subcommand . . . . . : 6
Test binds no plan ID . . . . . : 0
Packages bound . . . . . : 4
Package ADD subcommands . . . . . : 0
Package REPLACE subcommands . . . . . : 4

Rebind
Plan subcommands . . . . . : 0
Plan attempts . . . . . : 0
Plan successful . . . . . : 0
Package subcommands . . . . . : 0
Package attempts . . . . . : 0
Package successful . . . . . : 0

Autobind
Plan attempts . . . . . : 6
Plan successful . . . . . : 2
Invalid resource ID . . . . . : 4
Package attempts . . . . . : 0
Package successful . . . . . : 0

Free
Plan subcommands . . . . . : 0
Plan attempts . . . . . : 0
Plan successful . . . . . : 0
Package subcommands . . . . . : 0
Package attempts . . . . . : 0
Package successful . . . . . : 0

Command ==>
-----
F1=Help      F2=Split    F3=Exit     F5=Auto     F6=History
F7=Up       F8=Down    F9=Swap    F10=Delta  F11=Interval
F12=Cancel  F16=Look   F17=Collect

```

Figure 91. Bind Processing window

The Bind Processing window consists of the following sections:

Bind

This section shows statistics on bind events. These events occur when an explicit Db2 BIND subcommand is issued to bind a plan or package.

Rebind

This section shows statistics on rebind events. These events occur when an explicit Db2 REBIND subcommand is issued to rebind an existing plan or package.

Autobind

This section shows statistics on autobind events. These events occur if the plan becomes invalid since the last time the plan was bound. In this case, Db2 rebinds the plan before the plan is executed.

Free

This section shows statistics on free events. These events occur when an explicit Db2 FREE subcommand is issued to remove a Db2 plan or package from the Db2 catalog and directory.

Plan and Package Allocation window

Use the Plan and Package Allocation window to check plan and package allocation attempts and successes, and authorization management attempts and successes.

To display this window, select Plan/Package Allocation, Authorization Management from the Db2 Statistics Detail panel.

```

DGOMSWSV          Plan and Package Allocation

                                INTERVAL  2:48.421
                                More:    - +

Plan Allocation
  Attempts . . . . . : 111
  Successful . . . . . : 107

Package Allocation
  Attempts . . . . . : 11
  Successful . . . . . : 11

Plan Authorization Management
  Attempts . . . . . : 206
  Successful . . . . . : 206
  Successful without catalog access . . . . . : 65
  Successful public plan . . . . . : 65

Package Authorization Management
  Successful . . . . . : 3
  Successful public . . . . . : 1
  Unsuccessful - catalog required . . . . . : 1
  Overwritten authid in cache . . . . . : 1
  Overwritten in cache . . . . . : 1

Command ==> -----
  F1=Help      F2=Split      F3=Exit      F5=Auto

  F6=History   F7=Up         F8=Down     F9=Swap
  F10=Delta    F11=Interval  F12=Cancel  F16=Look
  F17=Collect

```

Figure 92. Plan and Package Allocation window

Successful without catalog access

The number of successful authorization checks not using the Db2 catalog, that is, using plan cache checks and public checks.

For transaction level security, ENABLE and DISABLE on BIND PACKAGE should be used to ensure adequate security. Granting execute authority on the plan to public might be quite adequate. See [IBM Db2 for z/OS in the IBM Knowledge Center](#) for more information.

Log Manager window

Use the Log Manager window to check Read and Write activity both to and from the log.

To display this window, select Log Manager from the Db2 Statistics Detail panel.

```

DGOMSWLG                               Log Manager

                                           INTERVAL  2:48.421
                                           More:      - +
Reads satisfied
  From output buffer . . . . . : 0
  From active log . . . . . : 1475
  From archive log . . . . . : 0

Reads delayed
  Tape volume contention . . . . . : 0
  Unavailable resource . . . . . : 0

Look ahead mounts attempted . . . . . : 23
Look ahead mounts successful . . . . . : 3

Write-no-wait . . . . . : 151
Write output log buffers . . . . . : 3

Total BSDS access requests . . . . . : 26
Unavailable output log buffers . . . . . : 0

Active log
  Control intervals created . . . . . : 3

Archive log
  Read allocations . . . . . : 0
  Write allocations . . . . . : 0
  Control intervals offloaded . . . . . : 0

Output log buffer writes per
  active log control interval created . . . . . : 1.0

Command ==> -----
F1=Help      F2=Split    F3=Exit     F5=Auto     F6=History
F7=Up        F8=Down     F9=Swap     F10=Delta   F11=Interval
F12=Cancel   F16=Look    F17=Collect

```

Figure 93. Log Manager window

If a high percentage of reads comes from the archive log, it might be necessary to increase the size of the active log. For example, a large update job with few commits could fill the active log forcing an archive. If the job fails, recovery is required to retrieve records from the archive log. Archive activity can be expensive in terms of response time, especially if the archive log is placed on slow devices such as tape or cartridge.

The following list describes some of the important fields that are shown in this panel:

Reads delayed - Tape volume contention

Number of read accesses delayed because of tape volume contention (that is, a tape volume was already in use by another thread).

Reads delayed - Unavailable resource

Number of read accesses delayed because of an unavailable resource. This can be because of an insufficient number of tape units allocated, or because the archive log read service task is not available.

Write output log buffers

The number of Write requests issued irrespective of single or dual logging. This field is updated once per buffer Write. The update value is either one or two I/Os, depending on which logging option is chosen (single or dual). This should have a value consistent with the known workload update rate.

Unavailable output log buffers

This field shows how many times a Write request to the active log had to wait because no buffer was available. The value should ideally be zero as these waits should not occur. If these waits do occur, the output buffer might be too small, or the size of the write threshold might be too close to the size of the output buffer.

Active log - Control intervals created

Number of active log output control intervals created. Log records are placed sequentially in output log buffers, which are formatted as VSAM control intervals. The control intervals are written to a set of predefined active log data sets, which are used sequentially and recycled.

A useful ratio is: Write output log buffers divided by Active log - Control intervals created.

Logging Considerations

- Minimize device contention on the log data sets by placing data sets correctly. If you use dual logging, do not place both logs on the same volume.
- Avoid waits that occur because no log buffer is available.
- Define enough active log data sets to prevent Db2 from waiting while a log is archived.
- Make the active logs large enough that backouts do not have to use the archive log.
- Consider the 3990 DASD FAST WRITE controller for the log. Performance measurements have shown that sequential access mode with DASD FAST WRITE provided substantially better performance than native DASD when the amount of log data written per commit was 24 KB or less. DASD FAST WRITE performance was comparable to that of native DASD when 48 KB of log data was written to DASD for each commit. When more than 48 KB was written, native DASD performed better than DASD FAST WRITE. Therefore there might be a need to determine in which environments log performance is critical to assess the value of DASD FAST WRITE.

Subsystem Service window

Use the Subsystem Service window to view Db2 subsystem activity, such as connections to Db2, threads, commits, and units of recovery. You can examine these statistics to determine the work load of various subsystem functions, and to help you adjust Db2 system parameters for optimum system performance.

To display this window, select Subsystem Service from the Db2 Statistics Detail panel.

```

DGOMSWSS          Subsystem Service

                                INTERVAL  2:48.421
                                More:      - +
Identify . . . . . : 60
Create thread . . . . . : 168
Signon . . . . . : 3
Terminate . . . . . : 107
Rollback . . . . . : 6

Synchs (single phase commit) . . . . . : 106
Queued at create thread . . . . . : 0

Commits
Phase 1 . . . . . : 1
Phase 2 . . . . . : 0
Read only . . . . . : 1

Subsystem allied memory
End of task . . . . . : 3
End of memory . . . . . : 0

System event checkpoints . . . . . : 2

Units of Recovery
Indoubt resolved . . . . . : 0
Gone indoubt . . . . . : 0

Command ==>
F1=Help   F2=Split  F3=Exit   F5=Auto   F6=History
F7=Up     F8=Down   F9=Swap  F10=Delta F11=Interval
F12=Cancel F16=Look  F17=Collect
  
```

Figure 94. Subsystem Service window

The following list describes some of the important fields that are shown in this panel:

Identify

The number of successful connections to Db2 from an allied address space (for example TSO, BATCH, CICS, IMS, CAF, RRSF, or UTILITY).

Create thread

The number of threads created. Thread creation can be a significant part of the cost in a short transaction. Thread reuse (discussed in [“Thread Reuse” on page 108](#)) can help improve performance.

Signon

The number of Signons that have occurred in IMS or CICS. If the number of Signons is greater than the number of Create Thread occurrences, some threads have been reused. In the case of the TSO attachment facility and the call attachment facility (CAF), there is no sign-on, because the user is identified when the TSO address space is connected.

Terminate

The number of threads that have been terminated. The value of this field is usually greater than the number of Create Thread occurrences, because it also includes the termination of connections to Db2 (IDENTIFY) and other internal counts.

Synchs (single phase commit)

The number of Commits from TSO, CAF, and UTILITY environments.

Queued at create thread

The number of Create Thread requests queued. This count does not include DBATs.

Monitoring this field is useful in determining the right setting for the MAX USERS option in the DSNTIPE installation panel. This parameter controls the number of threads (excluding DBATs) in the Db2 system.

Rule of thumb: About 1% thread queuing is acceptable.

Commits - Phase 1

The number of successful requests for COMMIT PHASE 1 of two-phase commit (BEGIN COMMIT). IMS, CICS, and RRS applications use the PREPARE and COMMIT sequence to commit work. This value does not include successful single-phase commits.

Commits - Phase 2

The number of successful requests for COMMIT PHASE 2. IMS, CICS, and RRS applications use the PREPARE and COMMIT sequence to commit work. This value does not include successful single-phase commits. A nonzero value for this field indicates that updates have occurred.

Commits - Read only

The number of times read operations were completed in a two-phase commit environment.

System event checkpoints

A count of the number of checkpoints Db2 has taken. The checkpoint interval is defined by the number of log records that you specify for the checkpoint frequency (LOGLOAD in DSN6SYSP). A checkpoint is taken when the specified number of log records have been written. A checkpoint is also taken each time Db2 switches to a new active log data set. If the statistics interval is 30 minutes and the value of this field is 15, then Db2 is taking checkpoints every 2 minutes.

Thread Reuse

The term *thread reuse* only applies to IMS and CICS attachments. In the case of the TSO attachment facility and the call attachment facility (CAF), threads cannot be reused, because the threads are allocated to the user address space.

Thread reuse should be considered in the following cases:

- If transaction volume is high:

High volume transactions should achieve a high percentage of thread reuse. If threads are reused on low volume transactions, the number of threads needed increases because these threads are not automatically terminated by IMS when not being used. This can result in too many idle threads for the level of the Db2 workload. Under CICS, protected threads are terminated after the purge cycle if no transaction eligible to reuse the thread has been received.

- If thread creation cost is significant:

As a rule of thumb, more than 5% of the total CPU cost of transaction processing is considered significant.

The ACQUIRE and RELEASE parameters of BIND should be specified to minimize the thread creation cost, while providing the needed concurrency:

- If most of the application plan's SQL statements are executed, then ACQUIRE(ALLOCATE) is cheaper than ACQUIRE(USE).
- If only a small number of the SQL statements are executed, ACQUIRE(USE) becomes cheaper and improves concurrency, because the required resources are only acquired (locked) when the plan actually references (uses) them. An example would be a generalized plan used by many different transactions. It would contain multiple logic paths referencing different tables.

If packages are involved, ACQUIRE(USE) is always implicitly used.

- Concurrency in thread reuse is based on page locking provided by the IS and IX intent locks, whose duration is governed by ACQUIRE and RELEASE of BIND.

RELEASE(DEALLOCATE) is recommended for thread-reuse transactions to reduce transaction CPU time.

When thread reuse is implemented, monitor the EDM pool. It should be sufficient in size to accommodate expanding plans where the next transaction requires additional plan sections over those already part of the EDM pool.

SQL Activity window

Use the SQL Activity window to view subsystem-wide SQL activity for determining the SQL workload on the system. This information displays the number of times each SQL statement has been executed. To display this window, select SQL Activity from the Db2 Statistics Detail panel.

```

DGOMWSQ          SQL Activity

                    INTERVAL  2:48.421

                    More:  - +
Incremental Binds . . . . . :          0

Total DML . . . . . :          108
  Select . . . . . :           2
  Insert . . . . . :           0
  Update . . . . . :           0
  Delete . . . . . :           0
  Prepare . . . . . :          10
  Describe . . . . . :           0
  Describe Table . . . . . :           0
  Open Cursor . . . . . :           3
  Close Cursor . . . . . :           3
  Fetch . . . . . :           90

Total DCL . . . . . :           4
  Lock Table . . . . . :           0
  Grant . . . . . :             4
  Revoke . . . . . :            0
  Set Current SQLID . . . . . :            0
  Set Host Variable . . . . . :            0
  Set Current Degree . . . . . :            0
  Connect Type 1 . . . . . :            0
  Connect Type 2 . . . . . :            0
  Set Connection . . . . . :            0
  Release . . . . . :            0
  Set current rules . . . . . :            0
  SQL call . . . . . :            0
  Associate locators . . . . . :            5
  Allocate cursor . . . . . :            3

Total DDL . . . . . :          10
  Rename table . . . . . :            0
  Comment On . . . . . :            0
  Label On . . . . . :            0

                CREATE      DROP      ALTER
Table . . . . . :           1         1         0
Temp. Table . . :           5        N/A        N/A
Index . . . . . :           0         0         0
Tablespace . . . :           0         0         0
Database . . . . :           0         0         0
Stogroup . . . . :           0         0         0
Synonym . . . . . :           0         0        N/A
View . . . . . :            0         0        N/A
Alias . . . . . :            3         0        N/A
Package . . . . . :           N/A        0        N/A

Command ==> -----
F1=Help      F2=Split    F3=Exit     F5=Auto
F6=History   F7=Up       F8=Down     F9=Swap
F10=Delta    F11=Interval F12=Cancel  F16=Look
F17=Collect

```

Figure 95. SQL Activity window (Statistics)

The SQL Activity window consists of the following sections:

Total DML (Data Manipulation Language)

This section shows the number of executions performed by various SQL statements concerning the manipulation of data.

Total DCL (Data Control Language)

This section shows the number of executions performed by various SQL statements concerning the controlling of various activities.

Total DDL (Data Definition Language)

This section shows a table that contain the number of executions performed by various DDL SQL statements for each of the applicable object types. These SQL statements are used to create, drop, and alter objects.

Incremental Binds

This field is the number of INCREMENTAL BINDs.

If a plan is bound with VALIDATE(RUN), Db2 performs validity checks (such as authorizations and existence of referenced Db2 objects) at bind time and rechecks any failures at run time. This can result in catalog contention and degraded application performance, depending on the number of statements flagged and the number of times they are executed. Therefore VALIDATE(RUN) should be avoided as much as possible. Ensure that all objects are created and all privileges are granted before binding, and select the VALIDATE(BIND) option.

In addition to plans bound with VALIDATE(RUN), this counter is incremented for plans using Db2 private protocol.

PREPARE Detail window

Use the PREPARE Detail window to view information about the treatment of PREPARE commands and information about kept dynamic statements and dynamic cached statements.

To display this window, select PREPARE Detail from the Db2 Statistics Detail panel.

```
DGOMSWPD          PREPARE Detail

Prepares satisfied . . . . . :          123
Prepares received  . . . . . :           4
Prepares implicit  . . . . . :          12
Prepares avoided   . . . . . :        12223
Kept dynamic statement discarded . . . . . :          12
Dynamic cache statement purged . . . . . :           4

Command ==> -----
F1=Help      F2=Split   F3=Exit     F5=Auto
F6=History   F9=Swap      F10=Delta   F11=Interval
F12=Cancel
```

Figure 96. PREPARE Detail window (Statistics)

The following list describes some of the important fields that are shown in this panel:

Prepares satisfied

The number of times a PREPARE command was satisfied by copying a statement from the prepared statement cache.

Prepares received

The number of times a PREPARE command was received, but a matching statement was not found in the prepared statement cache. Cache search is only done for DML SQL.

Prepares implicit

The number of times an implicit prepare was performed because KEEP DYNAMIC(YES) was used and an open, execute, or describe for a dynamic SQL statement has occurred after a commit.

Prepares avoided

The number of times a prepare was avoided because the KEEP DYNAMIC(YES) bind option was used and an open, execute, or describe for a dynamic SQL statement has occurred after a commit.

Kept dynamic statement discarded

The number of times a kept dynamic statement was discarded because the MAXKEEPD system limit has been reached.

Dynamic cache statement purged

The number of times a dynamic cached statement was purged from the cache because a dependent object was dropped or altered.

Query Parallelism Data window

Use the Query Parallelism Data window to view information about the total number of parallel groups executed and to find out whether the type or degree of parallelism was changed at run time.

To display this window, select Query Parallelism Data from the Db2 Statistics Detail panel.

```

DGOMSWQP          Query Parallelism Data

                                INTERVAL  3:32.419
                                More:      - +
Maximum Degree of Parallelism . . . . . :    0
Parallel Groups executed . . . . .       :    0

Number of Parallel Groups executed with
Planned Parallel Degree . . . . .       :    0
Reduced Parallel Degree
  No buffer . . . . .                   :    0
One DB2
COORDINATOR Parm = NO . . . . .         :    0
Isolation level . . . . .               :    0
Fall back to sequential mode
Cursor . . . . .                       :    0
No ESA . . . . .                       :    0
No Buffer . . . . .                     :    0
MVS/ESA Enclave Services . . . . .     :    0

Member skipped (%) . . . . .            :    3

Command ===> -----
F1=Help      F2=Split      F3=Exit      F5=Auto
F6=History   F9=Swap       F10=Delta   F11=Interval
F12=Cancel
  
```

Figure 97. Query Parallelism Data window (Statistics)

The main objective of query parallelism is to improve query response times.

Query parallelism is suited to *data-intensive* and *complex* queries. A query is *data-intensive* if it has a high ratio of I/O compared to CPU. A query is *complex* if it requires a high use of CPU to resolve complex predicates and functions.

By examining the information displayed in this window, you can view the number of parallel groups that have fallen back to sequential mode and determine the cause.

The following list describes some of the important fields that are shown in this panel:

Number of Parallel Groups executed with - One Db2 - COORDINATOR Parm = NO

The total number of parallel groups scheduled for Sysplex query parallelism, but executed on a single Db2 because of the COORDINATOR subsystem parameter set to NO. When the statement was bound, the COORDINATOR subsystem parameter was set to YES. The same can happen when a package or plan is bound on a Db2 subsystem with COORDINATOR = YES, but is run on a Db2 subsystem with COORDINATOR = NO.

Number of Parallel Groups executed with - One Db2 - Isolation level

The total number of parallel groups scheduled for Sysplex query parallelism, but executed on a single Db2 because of repeatable-read or read-stability isolation.

Member skipped (%)

The percentage of parallel groups that were not distributed as planned.

The purpose of this count is to indicate situations with insufficient buffers on a member so that the parallelism coordinator has to bypass a Db2 when distributing tasks.

RID List Processing window

Use the RID List Processing window to view the number of blocks concurrently allocated for RID entries (maximum and current), and the number of times RID list processing has been terminated.

To display this window, select RID List Processing from the Db2 Statistics Detail panel.

```
DGOMSWRP      RID List Processing

                INTERVAL  3:32.419
                More:    - +
RID blocks allocated
  Maximum . . . . . :    6
  Current . . . . . :    0

Terminated
  No storage . . . . . :    0
  RDS limit exceeded . . . . . :    0
  DM limit exceeded . . . . . :    0

  Process limit exceeded . . . . . :    0

Command ==> -----
  F1=Help      F2=Split    F3=Exit      F5=Auto
  F6=History   F9=Swap     F10=Delta   F11=Interval
  F12=Cancel   F16=Look    F17=Collect
```

Figure 98. RID List Processing window (Statistics)

RID list processing can terminate because the number of RID entries exceeds the RDS limit, the number of RID entries exceeds the data manager limit, or because the maximum RID list storage is exceeded.

The following list describes some of the important fields that are shown in this panel:

Terminated - No storage

Number of times RID list processing was terminated because of insufficient storage.

This failure occurs when the 2 GB limit is reached. You cannot increase virtual storage beyond 2 GB.

Terminated - RDS limit exceeded

The number of times RID list processing was terminated because either the number of RID entries was greater than the maximum limit of 25% of the table size, or because the number of RID entries that can fit into the guaranteed number of RID blocks was exceeded. The latter can only happen when RID blocks allocated - Maximum approaches the RID list storage size. There is one guaranteed RID block.

Terminated - DM limit exceeded

Number of times RID list processing was terminated because the number of RID entries exceeded the Data Manager limit of 16 million.

Terminated - Process limit exceeded

Number of times RID list processing was terminated because of the maximum RID list storage used.

The size is determined by the installation parameter RID POOL SIZE (Db2 Install panel DSNTIPC). It can be 0, or between 16 KB and 1 GB.

The general formula for calculating the RID pool size is:

$$\text{Number of concurrent RID processing activities} \times \text{average number of RIDs} \times 2 \times 5 \text{ bytes per RID}$$

Distributed Data window

Use the Distributed Data window to view subsystem-wide Distributed Data Facility (DDF) activity, and to examine a list of remote locations involved in this activity. If many remote locations are involved in distributed activity, you can use the scrolling keys F7 (Up) and F8 (Down) to browse the list.

To display this window, select Distributed Data from the Db2 Statistics Detail panel.

```

DGOMSWDD                Distributed Data                ROW 2 TO 2 OF 2
                                INTERVAL 3:03.838
For additional details, type any character next to the location,
then press Enter.

DBATs queued - maximum active . . . . . :      0
Conversations deallocated - maximum concurrent . . :      0
Active / Inactive DBATs currently . . . . . :      0 /      0
Active / Inactive DBATs high water mark . . . . . :     14 /      0
Total DBATs high water mark . . . . . :     14
Cold / warm start connections . . . . . :      0 /      0
Resynchronization attempted / succeeded . . . . . :      0 /      0

  Location                Transactions    Conversations
_ DSNAPC5                Sent           12           12
                        Recv           0            0
_ DSNAPC1                Sent           2            2
                        Recv           0            0
--- End of Location List ---

Command ==>
F1=Help      F2=Split    F3=Exit     F5=Auto     F6=History
F7=Up        F8=Down     F9=Swap     F10=Delta   F11=Interval
F12=Cancel   F16=Look    F17=Collect

```

Figure 99. Distributed Data window (Statistics)

From this window, you can select any remote location listed to display the Remote Location window, where the remote location can be examined in greater detail.

DBATs queued - maximum active

Monitoring this field is useful in developing the right setting for the DSNTIPE parameter MAX REMOTE ACTIVE. This parameter controls the number of DBATs that can be concurrently active in the Db2 system.

Rule of thumb: About 1% DBAT queuing is acceptable.

Note: The Distributed Data window is not accessible if there is no distributed activity.

Notes on MAX REMOTE ACTIVE

The MAX REMOTE ACTIVE option in the Install panel DSNTIPE specifies the number of database access threads that can be active at the same time as opposed to MAX USERS in the same panel which specifies the maximum number of allied threads. The combined maximum allowed for MAX USERS and MAX REMOTE ACTIVE cannot exceed 2 000.

MAX REMOTE CONNECTED in the Db2 Install panel DSNTIPE represents the number of database access threads that can concurrently exist. This number cannot exceed 25 000.

The total number of inactive database access threads is the difference between MAX REMOTE CONNECTED and MAX REMOTE ACTIVE.

An installation might choose, by means of DDF THREADS in the Db2 Install panel DSNTIPR, to have database access threads considered inactive when the last operation of the thread was a commit or rollback, all packages used by the database access thread had the RELEASE (COMMIT) option, and the thread holds no database locks (including not having any cursors open with the HOLD option). When this is the case, the thread is removed from active thread lists and moved to inactive thread lists.

If the limit set by MAX REMOTE ACTIVE parameter is reached, remote SQL requests are queued until a DBAT can be created. The number of times queuing occurred is shown by the field DBATs queued - maximum active. If necessary, the value of MAX REMOTE ACTIVE should be increased.

Remote Location window

Use the Remote Location window to view statistics regarding the distribution of data by the remote location selected from the Distributed Data window. These statistics show the number of distributed data events performed at this remote location.

To display this window, select any remote location listed in the Distributed Data window.

```

DGOMSWRL                               Remote Location

                                           INTERVAL 6:35.240
                                           More:   - +
Remote Location . . . . . : DRDA REMOTE LOCS

Conversations queued . . . . . : 0
SQL statements bound . . . . . : 6002
Limited block fetch . . . . . : 0
Message buffer rows . . . . . : 0

Remote Location as coordinator
  Threads went indoubt . . . . . : 0
  Commits performed . . . . . : 0
  Rollbacks performed . . . . . : 0

                                           Sent           Received

Transactions . . . . . : 12           0
Conversations . . . . . : 12           0
SQL statements . . . . . : 10003        0
Commits . . . . . : 9                 0
Rollbacks . . . . . : 2               0
Rows . . . . . : 0                   1
Messages . . . . . : 10022            10016
Bytes . . . . . : 4261K                2948K
Blocks . . . . . : 0                   0
Prepare requests . . . . . : 0          0
Last agent requests . . . . . : 0       0
Two phase commit requests . . . . . : 0  0
Two phase backout requests . . . . . : 0  0
Forget responses . . . . . : 0          0
Commit responses . . . . . : 0         0
Backout responses . . . . . : 0         0

Command ==> -----
F1=Help      F2=Split    F3=Exit     F5=Auto     F6=History
F7=Up        F8=Down     F9=Swap    F10=Delta   F11=Interval
F12=Cancel   F16=Look    F17=Collect

```

Figure 100. Remote Location window

To leave the Remote Location window and return to the Distributed Data window, press F3 (Exit). To leave the Remote Location window and return to the Db2 Statistics Detail panel, press F12 (Cancel).

The following list describes some of the important fields that are shown in this panel:

Remote Location

Location name of the remote location with which DDF data is associated, or, for DRDA protocol, this field contains the string DRDA REMOTE LOCS. Statistics for all remote locations accessed by DRDA protocol are grouped under the location name DRDA REMOTE LOCS. For Db2 private protocol, statistics are gathered independently for each remote location.

Conversations queued

The number of conversation requests that are queued by the Distributed Data Facility and are waiting for allocation.

If this number is high, consider tuning VTAM.

Limited block fetch

The number of times a switch was made from continuous to limited block fetch mode. This value applies only to Db2 private protocol.

If this number is high, consider tuning VTAM.

CPU Times and Other Data window

Use the CPU Times and Other Data window to view statistics on the work that various address spaces have accumulated.

To display this window, select CPU Times and Other Data from the Db2 Statistics Detail panel.

```

DGOMSWOT                CPU Times and Other Data

                                INTERVAL 6:35.240
For additional details, type any character next to heading, then
press Enter.

                                More:  - +

CPU Times
                                TCB           SRB           Total
                                Time           Time           Time
System Services . . . . . : 0.54272    0.18774    0.73047
Database Services . . . . . : 0.65193    0.37567    1.02761
IRLM . . . . . : 0.02337    0.01779    0.04116
DDF address space . . . . . : 0.11245    0.03937    0.15183

DB2 Application Programming Interface
Abends . . . . . : 0
Unrecognized . . . . . : 0
Command requests . . . . . : 1
READA requests . . . . . : 0
READS requests . . . . . : 7
WRITE requests . . . . . : 0

Miscellaneous
Log RBA . . . . . : X'000000000EB8C7E6'
Reason invoked . . . . . : IFI READS
Columns bypassed . . . . . : 89321

_ DB2 Commands
_ Instrumentation Record Counts
_ IFC Destination Data
_ Data Capture

Command ==> -----
F1=Help      F2=Split    F3=Exit     F5=Auto     F6=History
F7=Up        F8=Down    F9=Swap     F10=Delta   F11=Interval
F12=Cancel   F16=Look   F17=Collect

```

Figure 101. Statistics CPU Times and Other Data window

The 1 fields display statistics on the accumulated CPU processing time spent in various address spaces, and on various tasks. Use these statistics to examine system usage, and to determine if there are any problem areas consuming more CPU time than expected. If the Distributed Data Facility (DDF) is not installed, N/P is displayed in the DDF address space time fields.

The 1 fields show the number of calls made to the instrumentation facility interface (IFI) by various functions, and the number of IFI abnormal terminations.

From the CPU Times and Other Data window, you can reach windows that display information about Db2 commands, instrumentation record counts, IFC destination data, and data capture.

Db2 Commands window

Use the Db2 Commands window to view the total number of executions of various Db2 commands, whether or not they completed successfully.

To display this window, select DB2 Commands from the CPU Times and Other Data window.

```

DGOMSWCM          DB2 Commands

                    INTERVAL 16.103
                    More:   - +
Start database . . . . . : 0
Start trace . . . . . : 2
Start DB2 . . . . . : 1
Start RLIMIT . . . . . : 0
Start DDF . . . . . : 0
Start Procedure . . . . . : 0

Display database . . . . . : 0
Display thread . . . . . : 0
Display utility . . . . . : 0
Display trace . . . . . : 4
Display RLIMIT . . . . . : 0
Display location . . . . . : 0
Display archive . . . . . : 0
Display bufferpool . . . . . : 0
Display Groupbufferpool . . . . . : 0
Display Group . . . . . : 0
Display Procedure . . . . . : 0

Stop database . . . . . : 0
Stop trace . . . . . : 1
Stop DB2 . . . . . : 0
Stop RLIMIT . . . . . : 0
Stop DDF . . . . . : 0
Stop Procedure . . . . . : 0

Cancel thread . . . . . : 0
Recover BSDS . . . . . : 0
Recover Indoubt . . . . . : 0
Reset Indoubt . . . . . : 0
Reset Genericclu . . . . . : 0
Modify trace . . . . . : 0
Term utility . . . . . : 0
Archive log . . . . . : 0
Set archive . . . . . : 0
Alter bufferpool . . . . . : 0
Alter Groupbufferpool . . . . . : 0

Unrecognized commands . . . . . : 0

Command ==> -----
F1=Help      F2=Split    F3=Exit     F5=Auto
F6=History   F7=Up       F8=Down     F9=Swap
F10=Delta    F11=Interval F12=Cancel  F16=Look
F17=Collect

```

Figure 102. Db2 Commands window

Db2 Instrumentation window

Use the Db2 Instrumentation window to view the number of records successfully written by the Db2 instrumentation facility to SMF, GTF, and OPx destinations, and the number of records where a Write was attempted but did not succeed.

To display this window, select Instrumentation Record Counts from the CPU Time and Other Data window.

```

DGOMSWIN                DB2 Instrumentation

                                INTERVAL 16:14.034

Type of record                Written      Not Written

System related . . . . . :           5           4
Database related . . . . . :          5           4
Accounting . . . . . :          15           0
Start trace . . . . . :             1           0
Stop trace . . . . . :              0           0
DSNZPARM . . . . . :               8           1
Audit . . . . . :                   0           0

Command ==>
F1=Help   F2=Split   F3=Exit   F5=Auto   F6=History
F9=Swap   F10=Delta  F11=Interval F12=Cancel F16=Look
F17=Collect

```

Figure 103. Db2 Instrumentation window

Unsuccessful writes can be caused by buffer full conditions or other failures.

Db2 IFC Destinations window

Use the Db2 IFC Destinations window to view the number of instrumentation records that are written to IFC destinations, and the number of various failures.

To display this window, select IFC Destination Data from the CPU Times and Other Data window.

```

DGOMSWIF                DB2 IFC Destinations

                                INTERVAL 16:14.034

Destination                Written      Not      Buffer      Not      Write
                             Written      Written  Overrun   Accepted  Failure

SMF . . . :                27           0           0           0      More:  - +
GTF . . . :                 0           0          N/A         0           0
OP1 . . . :                 1           0          N/A         0          N/A
OP2 . . . :                 0           0          N/A         0          N/A
OP3 . . . :                 0           0          N/A         0          N/A
OP4 . . . :                 0           0          N/A         0          N/A
OP5 . . . :                 0           0          N/A         0          N/A
OP6 . . . :                 0           0          N/A         0          N/A
OP7 . . . :                 0           0          N/A         0          N/A
OP8 . . . :                 0           0          N/A         0          N/A
RES . . . :                 0           N/A         N/A         N/A         N/A

Command ==>
F1=Help   F2=Split   F3=Exit   F5=Auto   F6=History
F7=Up     F8=Down   F9=Swap   F10=Delta F11=Interval
F12=Cancel F16=Look  F17=Collect

```

Figure 104. Db2 IFC Destinations window

The IFC destinations in this window are:

- SMF**
System management facility
- GTF**
Generalized trace facility
- OP1 to OP8**
Output buffer destinations
- RES**
Resident trace table.

Use this window to examine instrumentation record Write activity, and identify possible problems. A nonzero value in the Not Written column can indicate a problem. In this case, check for nonzero values

in the Buffer Overrun, Not Accepted, and Write Failure columns to determine the possible cause.

Data Capture window

Use the Data Capture window to view statistics on data capture activity.

To display this window, select Data Capture from the CPU Times and Other Data window.

```
DGOMSWCD          Data Capture
                   INTERVAL 16:14.034

Log reads performed . . . . . :      1
Log records captured . . . . . :     15
Log records returned . . . . . :     11
Data rows returned . . . . . :     79
Data descriptions returned . . . . . :    2
Describes performed . . . . . :    2
Tables returned . . . . . :    2

Command ==> -----
F1=Help      F2=Split    F3=Exit      F5=Auto
F6=History   F9=Swap      F10=Delta    F11=Interval
F12=Cancel   F16=Look     F17=Collect
```

Figure 105. Data Capture window

The following list describes some of the important fields that are shown in this panel:

Log reads performed

The total number of data capture log reads for processing IFI READS requests for IFCID 185.

Log records captured

The number of log records retrieved for which data capture processing was invoked.

Log records returned

The total number of data capture log records returned.

Data rows returned

The total number of data capture data rows returned.

Data descriptions returned

The total number of data capture data descriptions returned.

Describes performed

The total number of data capture describes performed.

A data capture describe is the process of getting descriptive information about a Db2 table from the catalog.

Tables returned

The total number of data capture tables returned to the caller of an IFI READS call for IFCID 185.

Data Sharing Locking Activity window

Use the Data Sharing Locking Activity window to view statistical information about data sharing locking activity for the Db2 subsystem.

To display this window, select Data Sharing Locking Activity from the Db2 Statistics Detail panel. This selection is only available if the monitored Db2 subsystem is part of a data sharing group.

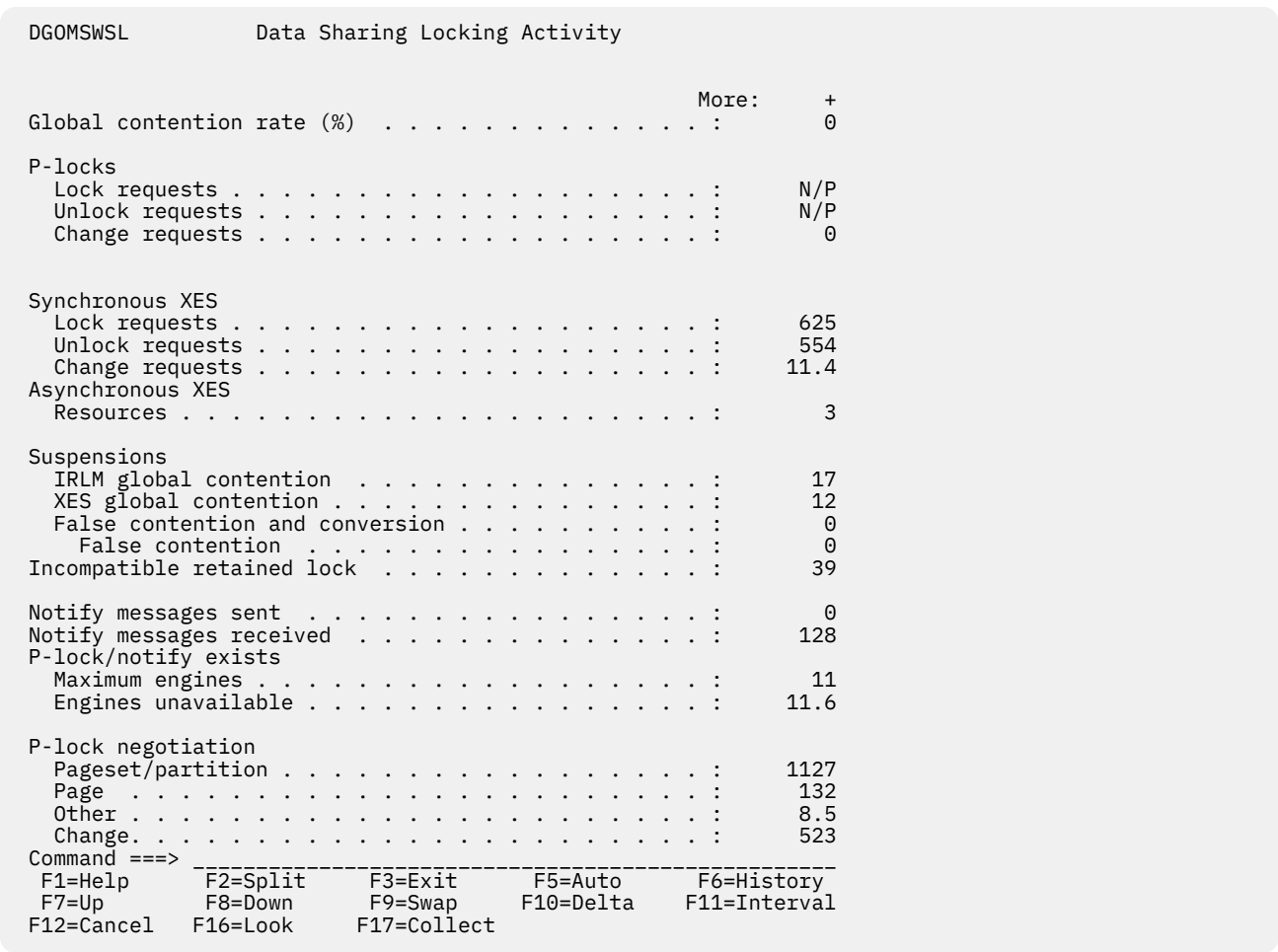

Figure 106. Data Sharing Locking Activity window

A logical lock (L-lock) is a lock used by transactions to control intra-DB2 and inter-DB2 data concurrency between transactions. A physical lock (P-lock) is a lock used only by data sharing and is acquired by Db2 to provide consistency on data cached in different Db2 subsystems. P-locks are owned by the subsystem, not by the transaction. XES is the Cross System Extended Services component of MVS. For more information about locking in a data sharing environment, see *Db2 Data Sharing: Planning and Administration*.

The following list describes the fields shown in this window:

Global contention rate (%)

The total number of suspends because of contention, divided by the total number of requests that went to XES (excluding asynchronous requests), multiplied by 100.

P-locks -- Lock requests

The number of lock requests for P-locks.

P-locks - Unlock requests

The number of unlock requests for P-locks.

P-locks - Change requests

The number of change requests for P-locks.

Synchronous XES - Lock requests

The number of lock requests propagated to MVS XES synchronously.

Synchronous XES - Unlock requests

The number of resources synchronously propagated to MVS XES by unlock requests.

Synchronous XES - Change requests

The number of change requests propagated to MVS XES synchronously.

Asynchronous XES - Resources

The number of resources propagated to MVS XES asynchronously by IRLM.

Suspensions - IRLM global contention

The number of suspensions because of IRLM global contention. IRLM lock states were in conflict.

Suspensions - XES global contention

The number of suspensions because of MVS XES global contention. MVS XES lock states were in conflict, but IRLM was not.

Suspensions - False contention and conversion

Summation of false contentions (see below) and sync-to-async heuristic conversions. Conversions are done when XES determines that it is more efficient to drive the request asynchronously to the CF.

False contention

The number of false contentions encountered on this z/OS image. A false contention occurs when different resource names hash to the same entry in the CF lock table. The CF detects contention within the hash entry, and XES uses inter-system messaging to determine that no actual resource contention exists. This counter is maintained on a per-LPAR basis. Therefore this counter over-reports false contentions in cases where multiple members from the same data sharing group run on the same z/OS image. The counter is not present (N/P) if data is unavailable because of errors from the IXLMG service.

Incompatible retained lock

The number of global lock or change requests rejected or suspended because of an incompatible retained lock.

Notify messages sent

The number of notify messages sent.

Notify messages received

The number of notify messages received.

P-lock/notify exits - Maximum engines

The maximum number of engines available for P-lock exit or notify exit requests.

P-lock/notify exits - Engines unavailable

The number of times an engine is not available for P-lock exit or notify exit requests.

P-lock negotiation - Pageset/partition

The number of times this Db2 was driven to negotiate a page set or partition P-lock because of changing inter-DB2 interest levels on the page set or partition.

P-lock negotiation - Page

The number of times this Db2 was driven to negotiate a page P-lock because of inter-DB2 P-lock contention.

P-lock negotiation - Other

The number of times this Db2 was driven to negotiate another P-lock type (other than pageset/partition or page).

P-lock negotiation - Change

The number of times a P-lock change request was issued during P-lock negotiation.

Group Buffer Pools Activity window

Use the Group Buffer Pools Activity window to view all group buffer pools used by the Db2 subsystem. If there are many group buffer pools listed, you can use the scrolling keys F7 (Up) and F8 (Down) to browse the list.

```
DGOMSWGB          Group Buffer Pools Activity          ROW 1 TO 1 OF 1

For additional details, type any character next to Group Buffer Pool
ID, then press Enter.

  Group Buffer      ----- Synchronous Read (XI) -----
  Pool ID          Data Returned      No data returned
-  GBP0              0                      0
-  TOTAL             0                      0
--- End of Group buffer pool list ---

Command ==> -----
  F1=Help          F2=Split          F3=Exit          F5=Auto          F6=History
  F7=Up            F8=Down          F9=Swap         F10=Delta        F11=Interval
  F12=Cancel       F16=Look         F17=Collect
```

Figure 107. Group Buffer Pools Activity window

You can select any group buffer pool ID listed in this window to display the Group Buffer Pool Detail window, where you can view Read and Write activity both to and from that particular group buffer pool, or select Total to view Read and Write activity on all of the listed group buffer pools combined.

Group Buffer Pool Detail window

Use the Group Buffer Pool Detail window to view statistics on the group buffer pool selected from the Group Buffer Pools Activity window. These statistics show Read and Write activity both to and from that buffer pool. If Total was selected from the Group Buffer Pools Activity window, the Group Buffer Pool Detail window shows combined statistics on all group buffer pools used by the thread.

```

DGOMSWG D          Group Buffer Pool Detail

More:  - +

Group Buffer Pool ID . . . . . :  GBP0

Synchronous read (Cross invalidation)
  Data returned . . . . . :  0
  No data returned . . . . . :  0
Synchronous read (not found)
  Data returned . . . . . :  0
  No data returned . . . . . :  0
Unregister page . . . . . :  0

Clean pages written synchronously . . . . . :  0
Changed pages written synchronously . . . . . :  0
Clean pages written asynchronously . . . . . :  0
Changed pages written asynchronously . . . . . :  0

Asynchronous read - data returned . . . . . :  0
Asynchronous read - no data returned. . . . . :  0
Register page list request . . . . . :  0
Clean pages read after register page list . . . . . :  0
Changed pages read after register page list . . . . . :  0

Pages Castout . . . . . :  0
Unlock castout . . . . . :  3
Read castout class . . . . . :  5
Read castout statistics . . . . . :  5

Read directory info . . . . . :  21
Read storage statistics . . . . . :  1
Register page . . . . . :  11
Delete name . . . . . :  0

Castout class threshold . . . . . :  0
Group buffer pool castout threshold . . . . . :  0
GBP checkpoints triggered . . . . . :  1
Participate in GBP rebuild . . . . . :  0

Castout engine unavailable . . . . . :  0
Write engine unavailable . . . . . :  0
Read failed - no storage . . . . . :  0
Write failed - no storage . . . . . :  0
Command ==>
  F1=Help      F2=Split    F3=Exit     F5=Auto     F6=History
  F7=Up        F8=Down    F9=Swap    F10=Delta   F11=Interval
  F12=Cancel   F16=Look   F17=Collect

```

Figure 108. Group Buffer Pool Detail window

The following list describes some of the important fields that are shown in this panel:

Synchronous read (Cross invalidation) - Data returned

The number of synchronous coupling facility read requests caused by the page in the member's buffer pool that is marked invalid. Data is returned from the group buffer pool.

Synchronous read (Cross invalidation) - No data returned

The number of synchronous coupling facility read requests caused by the page in the member's buffer pool that is marked invalid. Data is not returned from the group buffer pool but from a hard disk drive.

Synchronous read (not found) - Data returned

The number of synchronous coupling facility read requests necessary because the requested page was not found in the buffer pool. Data was returned from the coupling facility.

Synchronous read (not found) - No data returned

The number of synchronous coupling facility read requests necessary because the requested page was not found in the buffer pool. Data is not returned from the group buffer pool but from a hard disk drive.

Unregister page

The number of times Db2 unregistered interest to the group buffer pool for a single page. This is generally done by Db2 when it steals pages from the local buffer pool that belong to group buffer pool dependent page sets or partitions.

Clean pages - Written asynchronously

The number of clean pages asynchronously written from the member's virtual pool to the group buffer pool. If a buffer pool threshold is reached, pages can be forced out before the application commits. This can also happen when P-lock negotiation forces the pages on the Vertical Deferred Write queue to be written to the group buffer pool.

Asynchronous read - Data returned

The number of coupling facility reads for Prefetch, in which data was returned from the coupling facility.

Asynchronous read - No data returned

The number of coupling facility reads for Prefetch, in which data was not returned from the coupling facility, and a coupling facility directory entry was created, if it did not already exist.

Pages Castout

The number of pages cast out from the group buffer pool to a hard disk drive.

Unlock castout

The number of times Db2 issued an unlock request to the coupling facility for castout I/Os that have completed. When pages are in the process of being cast out to a hard disk drive, they are locked for castout in the coupling facility. The castout lock is not an IRLM lock. Its purpose is to enforce that only one system can cast out a given page at a time.

Read castout class

The number of requests made to the group buffer pool to determine which pages belonging to a given page set or partition are cached in the group buffer pool as changed pages and therefore need not be cast out.

The read castout class request is issued by the page set or partition castout owner and by the group buffer pool structure owner when the GBPOOLT threshold has been reached.

Read castout statistics

The number of requests issued by the group buffer pool structure owner when the GBPOOLT threshold has been reached. These requests are to determine which castout classes have changed pages. Read castout statistics requests are usually issued only once or twice for each occurrence of the GBPOOLT threshold.

Read directory info

The number of requests (issued by the group buffer pool structure owner) for group buffer pool checkpoints to read the directory entries of all changed pages in the group buffer pool, so that the oldest recovery LRSN (Log Record Sequence Number, displayed in message DSNB798I) can be recorded and used for recovery purposes in case the group buffer pool fails. Read directory information requests might have to be issued several times for each group buffer pool checkpoint to read the directory entries for all changed pages.

Read storage statistics

The number of times Db2 requested statistics information from the group buffer pool. Usually this number should be relatively low. Requests for statistics information are issued once per group buffer pool checkpoint by the group buffer pool structure owner. They are also issued for DISPLAY GROUPBUFFERPOOL GDETAIL requests and to record IFCID 254.

Register page

The number of times Db2 registered interest to the group buffer pool for a single page. These are register-only requests, which means that Db2 does not request that data is returned for the page. Db2 knows that there is no data cached in the group buffer pool for this page. The only purpose of the register page request is to create a directory entry for the page for cross-invalidation when downgrading the P-lock on a page set or partition from S mode to IS mode, or from SIX mode to IX mode.

Delete name

The number of times Db2 issued a request to the group buffer pool to delete directory and data entries associated with a given page set or partition. Db2 issues this request when it converts a page set or partition from group buffer pool dependent to not group buffer pool dependent, and also for GBPCACHE ALL objects when the first Db2 member opens the object.

Read failed - no storage

The number of coupling facility read requests that could not complete because of a lack of coupling facility storage resources. If the value of this counter is constantly high, consider increasing the group buffer pool size.

Write failed - no storage

The number of coupling facility Write requests that could not complete because of a lack of coupling facility storage resources. If the value of this counter is constantly high, consider increasing the group buffer pool size.

Global Group Buffer Pool Statistics window

Use the Global Group Buffer Pool Statistics window to view various information about the number of coupling facility read requests for the group buffer pools.

While the Group Buffer Pools Activity window and the Group Buffer Pool Detail window display statistics on the group buffer pool usage of the currently monitored subsystem, the Global Group Buffer Pool Statistics window below and the associated Global GBP Statistics Detail window provide information about the group buffer pool usage across the entire data sharing group.

If there are many group buffer pools listed, you can use the scrolling keys F7 (Up) and F8 (Down) to browse the list.

To display this window, select Global Group Buffer Pool Statistics from the Db2 Statistics Detail panel. This selection is only available if the monitored Db2 subsystem is part of a data sharing group.

```
DGOMSWBC      Global Group Buffer Pool Statistics

For additional details, type any character next to Group Buffer Pool
ID, then press Enter.

  Group Buffer          Read hit          Read miss
  Pool ID              directory hit
-  GBP0                  0                  0
-  GBP7                  200                 0
-  GBP32K7              311                 0
-  Total                 511                 0
--- End of Group Buffer Pool List ---

Command ==> -----
F1=Help      F2=Split      F3=Exit      F5=Auto      F6=History
F7=Up        F8=Down       F9=Swap      F10=Delta    F11=Interval
F12=Cancel   F16=Look     F17=Collect
```

Figure 109. Global Group Buffer Pool Statistics window

You can select any group buffer pool listed in this window to display the Global GBP Statistics Detail window, where you can view more information about the buffer pool in greater detail.

Global GBP Statistics Detail window

Use the Global GBP Statistics Detail window to view statistics on coupling facility activity for the group buffer pool selected from the Global Group Buffer Pool Statistics window.

```
DGOMSWBD      Global GBP Statistics Detail

                                INTERVAL 2:54.251
                                More:    - +

Group buffer pool name . . . . . :      GBP1
Read hit . . . . . :                    258
Read miss directory hit. . . . . :      258
Read miss assignment suppressed . . . . . : 0
Read miss name assigned . . . . . :      557
Read miss cache full . . . . . :         0
Changed page write hit . . . . . :       705
Clean page write hit . . . . . :         0
Write miss cache full . . . . . :         0
Directory entry reclaim . . . . . :       0
Data entry reclaim . . . . . :          214
XI Directory entry reclaim . . . . . :     0
Castout . . . . . :                     398
Directory entry . . . . . :              843
Data entry . . . . . :                   183
Total changed . . . . . :                 67

Command ===>
F1=Help      F2=Split      F3=Exit      F5=Auto      F6=History
F7=Up        F8=Down       F9=Swap      F10=Delta   F11=Interval
F12=Cancel   F16=Look      F17=Collect
```

Figure 110. Global GBP Statistics Detail window

The following list describes some of the important fields that are shown in this panel:

Read miss assignment suppressed

The number of coupling facility read requests for a page, in which data was not returned, where the page name was not assigned in the coupling facility directory, and where directory name assignment is suppressed.

Db2 requests suppression of the directory entry assignment in cases where it does not have to register the page to coupling facility for cross-invalidation (XI). This is the case when Db2 is the only one in the group with Read/write interest in the page set or partition.

Read miss name assigned

The number of coupling facility read requests for a page, in which data was not returned, where the page name was not assigned in the coupling facility directory, but a directory entry was successfully assigned to the new name.

Read miss cache full

The number of coupling facility read requests for a page, in which the page name was not assigned to a coupling facility directory entry and where name assignment could not complete because of a lack of coupling facility storage resources.

Stored Procedures window

Use the Stored Procedures window to view activity on calls made to stored procedures.

```
DGOMSWSP          Stored Procedures
                                                           Interval 24.754
CALL statements executed . . . . . : 0
Procedure abends . . . . . : 0
CALL statement timeouts . . . . . : 0
CALL statements rejected . . . . . : 0

Command ==>
-----
F1=Help      F2=Split    F3=Exit     F5=Auto     F6=History
F7=Up        F8=Down     F9=Swap     F10=Delta   F11=Interval
F12=Cancel   F16=Look    F17=Collect
```

Figure 111. Stored Procedures window

The following list describes the fields shown in this window:

CALL statements executed

The number of SQL CALL statements executed.

Procedure abends

The number of times a called stored procedure terminated abnormally.

CALL statement timeouts

The number of times an SQL CALL statement timed out while waiting to be scheduled.

CALL statements rejected

The number of times an SQL CALL statement was rejected because of the procedure being in the STOP ACTION (REJECT) state.

Statistics commands

You can type statistics commands on any statistics panel command line, or invoke them using the function keys. A list of active function keys is displayed at the bottom of each panel. You can abbreviate commands down to three characters in length. For example, the AUTO command can be abbreviated to AUT.

AUTO command

Use the AUTO command to refresh values displayed in panels without having to press Enter. When you activate auto-display mode, the displayed values are updated periodically, as specified by the AUTO command. You cannot perform any other tasks with your Online Monitor session while auto-display mode is running.

The command syntax is:

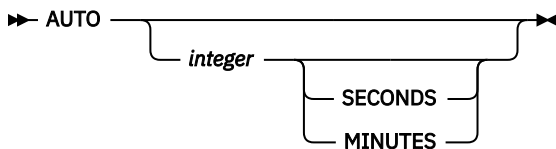

Figure 112. Syntax of the AUTO command

Parameters of the AUTO command

The AUTO command accepts the following parameters:

integer

Optional. Specifies the auto-display interval. The valid ranges are:

- 1 to 7 200 seconds
- 1 to 120 minutes

SECONDS

Optional. Specifies the auto-display unit in seconds. If no unit is specified, the default is seconds. If this parameter is specified, *integer* should also be specified.

MINUTES

Optional. Specifies the auto-display unit in minutes. If this parameter is specified, *integer* should also be specified.

If no parameters are specified, the values in the Auto Display window are used.

Starting Auto Display mode

To start Auto Display mode, type AUTO, followed by any parameters, on the command line and press Enter. The AUTO command can be abbreviated to AUT, the SECONDS to S, and the MINUTES to M.

To stop Auto Display, press the attention key.

Note: While the Online Monitor is executing a Db2 call (IFI or SQL), pressing the attention key might not stop the auto-display mode. An 'A' is displayed every time the key is pressed until attention processing is available again. For example, this is the case when the Online Monitor is issuing SQL statements to resolve names of locked resources.

Examples of the AUTO command

- AUTO 5 refreshes the panel with updated values every 5 seconds
- AUTO 1 MIN refreshes the panel with updated values every minute
- AUTO 10 refreshes the panel with updated values every 10 seconds
- AUTO uses the values specified in the Auto Display window

DELTA command

Use the DELTA command to view subsystem-wide Db2 statistics activity between the times that you press Enter.

The command syntax is:

➤ DELTA ➤

Figure 113. Syntax of the DELTA command

Selecting delta processing

To select delta processing mode, type DELTA on the command line and press Enter. DELTA can be truncated to a minimum of DEL.

Each time you press Enter, the displayed values are updated to reflect the system activity since the previous display update. If auto-display mode is active, the values are updated on each auto-display interval.

When DELTA is active, the DELTA time is displayed on the message line.

To return to regular mode, issue the RESET command.

INTERVAL command

Use the INTERVAL command to view an accumulation of statistics data from a specified point in time.

The command syntax is:

►► INTERVAL ◀◀

Figure 114. Syntax of the INTERVAL command

Selecting interval processing

To select interval processing mode, type INTERVAL on the command line and press Enter. INTERVAL can be truncated to a minimum of INT.

When you invoke interval mode, the time of the current display is used as a base point for further displays. Each time you press Enter to update the display in interval mode, the statistics data is accumulated from that base point. If the auto-display function is active, the values are updated automatically from the base point with each auto-display cycle.

When INTERVAL is active, the interval elapsed time is displayed on the message line.

To return to regular mode, issue the RESET command.

RESET command

Use RESET to deactivate delta or interval processing mode and revert back to regular display mode.

The command syntax is:

►► RESET ◀◀

Figure 115. Syntax of the RESET command

Resetting the processing mode

To deactivate delta or interval processing mode and revert back to regular display mode, type RESET on the command line and press Enter. RESET can be truncated to a minimum of RES.

History and statistics processing modes

History can be active simultaneously with either interval or delta processing mode.

Delta processing helps isolate Db2 statistics activity that occurs between user-specified points in time. When History is invoked, the delta is the time between the currently displayed statistical data and the data requested by the HISTORY command. The two sets of statistics records are checked to determine the oldest to avoid the calculation of negative DELTA values.

Interval processing helps isolate Db2 statistics activity beginning at a certain point in time. When History is invoked, the interval is the time between the first statistics data encountered after the INTERVAL command and the statistics data requested by the HISTORY command. The two sets of statistics records are checked to determine the oldest to avoid the calculation of negative INTERVAL values.

Monitoring the access path with Explain

Online Monitor Explain provides a real-time analysis of the access path methods that are chosen by Db2 for a given SQL statement. You can also modify the SQL statement text and reexplain it. This provides you with the ability to tune a Db2 subsystem while you are online.

This topic describes how to select the SQL statement you want to explain from within the Online Monitor or from within an ISPF/PDF editor, the authorization required to use Explain, performance considerations, tuning advice, and the Db2 Explain Output panel.

Online Monitor Explain is based on DB2's SQL Explain function. However, it translates the more important PLAN_TABLE codes into full English sentences, so you do not need to know the values and columns of the PLAN_TABLE. In addition, Online Monitor Explain provides direct access to related catalog information (the catalog statistics of the tables and indexes that are used in the SQL statement).

Authorizations required to use Explain

To explain an SQL statement, you need Db2 EXECUTE privilege on the OMEGAMON XE for Db2 PE Explain plan defined at installation. The name of this plan is KO2EXPL.

The following Db2 PLAN_TABLE privileges might also be required:

- Explain an entry in a plan table.

You require Db2 SELECT privilege on the PLAN_TABLE.

- Explain an SQL statement from a previously bound plan or package.

You require Db2 SELECT privilege on the plan or package owner's PLAN_TABLE. If you do not have the privilege, a dynamic Explain of the statement is performed if you have UPDATE privilege on your own PLAN_TABLE.

- Explain an SQL statement entered in the panel.

You require Db2 UPDATE privilege on your own PLAN_TABLE.

- Explain an SQL statement from a Thread Activity window.

You require Db2 SELECT privilege on the plan or package owner's PLAN_TABLE. If you do not have the privilege, a dynamic Explain of the statement is performed if you have UPDATE privilege on your own PLAN_TABLE.

- CREATE or ALTER a plan table.

You require a minimum of CREATETAB authority on the database that the PLAN_TABLE is created in, or ALTER authority to modify the PLAN_TABLE.

Performance considerations

The execution time to explain a plan or package depends on the number of rows in the accessed PLAN_TABLE. If the table has many rows, you can improve performance by creating an index on PROGNAME, QUERYNO. Alternatively, delete unnecessary rows from your PLAN_TABLE.

What to look for in Explain information

When an SQL statement is explained, it is important that the explaining takes place on the production Db2 subsystem, or at least on a Db2 subsystem where the catalog statistics have been updated to reflect the real production system in terms of table size, available indexes, and other key values. You can specify the "current server" on which Explain is to be executed. This option makes it possible that you are connected to a Db2 test subsystem while you execute the Explain on the remote production system.

The following Explain information can be useful in determining why an application does not perform as expected:

- Access path chosen

Table space scans and nonmatching index scans should be avoided, unless you intend to access all rows in a given table or the table is very small. If the table has one or more indexes, try to reconstruct the SQL statement in such a way that Db2 chooses a better access path. If there is no index, consider creating one.

- Index-Only-Access

When you only select a few column values, consider the possibility of including these few columns in the column list of one of the indexes. In this way, all requested data can be found in the index. The access path message informs you if you succeed in doing so. Likewise, if you select a maximum value, consider building a descending index on that column (or an ascending index, if you select a minimum value). In this way, you can even avoid the scanning of leaf pages in the index structure.

- Clustering versus clustered

If a clustering index has been chosen by Db2, ensure that the actual index is clustered. In the Index Information window, if the clustered value is NO, or if the cluster ratio is less than 95%, the table space might need a reorganization to bring the data rows into clustering sequence.

- Number of matching columns

On the Plan Table Data panel, if Db2 has selected a matching index scan, you should verify in the Index Information window that the number of columns used in the index is what you expect.

- Active pages versus pages with rows

Verify that the number of pages with rows is approximately the same as active pages, especially if you are performing table space scans. The value shown in the 1 field in the Table Information window should be as close as possible to 100 percent.

- Number of tables per table space

On the Table Space Information window, you should monitor the Tables field. This field shows the number of tables located in the table space. If the access path is Tablespace scan and the table space is not segmented, there should be only one table in the table space. In a nonsegmented table space, all tables are scanned, not only the selected table.

- Host variable definitions versus column definitions

An inconsistent definition of host variables shown in the Host Variable Definition window, compared to the corresponding column definitions shown in the Key Column Selection window, can indicate an inefficient access path selection, resulting from a possible disqualification of index usage. If, for example, an index column is defined as 3 characters, and that column is being compared in a WHERE-clause with a host variable defined as 4 characters, then Db2 does not base its access path selection on the mentioned index. You should verify that a column and a host variable being compared in a WHERE-clause have compatible definitions.

Plan table considerations

Whenever an SQL statement is explained, the result is written as an entry into a plan table. When the Explain function performs a dynamic Explain, the result is written to the PLAN_TABLE of the current SQLID. The current SQLID is either the same ID as the one used for your Online Monitor session or the ID that you specify in the Explain Menu. You can then examine the explained SQL statement residing in the plan table by using the Db2 Explain Output panel and its associated windows.

If you request a dynamic Explain of an SQL statement, and if you do not have an up-to-date plan table, one of these windows is displayed:

- If a plan table currently does not exist, the [“Create Plan Table window” on page 132](#) prompts you to create a plan table.
- If a plan table exists, but does not match your current version of Db2, the [“Upgrade Plan Table window” on page 132](#) prompts you to upgrade the plan table.

Create Plan Table window

If a plan table does not exist when a dynamic Explain is required, the Create Plan Table window is displayed.

Use the Create Plan Table window to specify the database name (optional), and table space name of the table to be created (optional). If neither are entered, a plan table is created in the default database DSNDDB04. If this database does not exist or you do not have sufficient authority, an error message is displayed.

```
DGOMYWQC                Create Plan Table

You do not have a plan table. Update the database name and table
space name as required, then press Enter to create the plan table.

Database name . . . . . DSNDDB04
Table space name . . . . .

F1=Help   F2=Split  F9=Swap  F12=Cancel
```

Figure 116. Create Plan Table window

Upgrade Plan Table window

If a plan table exists but does not match your current version of Db2, the Upgrade Plan Table window is displayed. Use this window to confirm that the table definition be upgraded to match your current version of Db2.

```
DGOMYWQU                Upgrade Plan Table

Your plan table definition does not include all the columns
required by DB2PM.

To upgrade the plan table, press Enter.

F1=Help   F2=Split  F9=Swap  F12=Cancel
```

Figure 117. Upgrade Plan Table window

Explain an SQL statement

You can explain an SQL statement by various actions.

- Entering the EXPLAIN command or pressing F18 (Explain) in any Thread Activity panel in either the SQL Statement and Package window or SQL Statement and DBRM window.

The current SQL statement is then explained.

- Selecting option 9 (Explain) from the Online Monitor Main Menu.

The Explain Menu is displayed, where you can select one of four options for explaining an SQL statement.

- Marking a range of lines to be explained from within an ISPF/PDF editor and issuing the EXPLAIN command from the editor command line.

See [“ISPF Online Monitor Source Explain” on page 141](#) for more information.

The SQL statement is then explained and the result displayed in the Db2 Explain Output panel.

[Figure 118 on page 133](#) shows the flow of the Explain process.

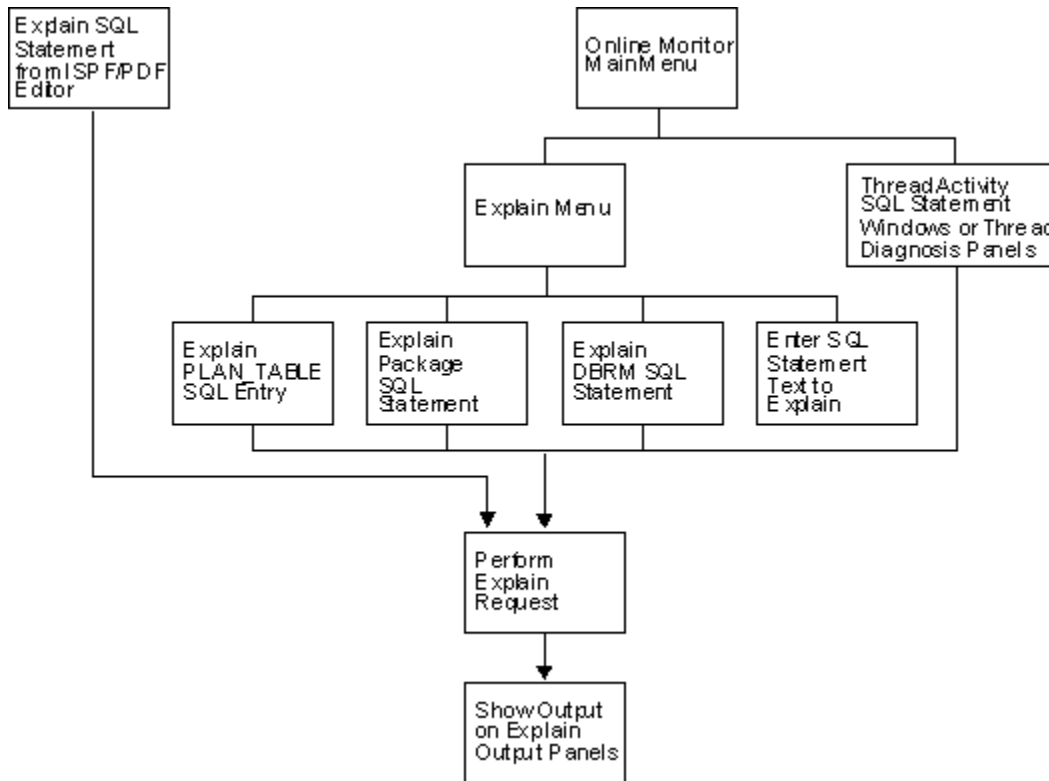

Figure 118. Flow of Explain process

Selecting Explain from the Online Monitor Main Menu

You can access Explain by selecting option 9 (Explain) from the Online Monitor Main Menu. See [Figure 1](#) on page 5 for an example of the Online Monitor Main Menu.

The Explain Menu is displayed, where you can select one of four methods for specifying the SQL statement you want explained.

Explaining an SQL statement from an ISPF/PDF editor

You can explain an SQL statement that is imbedded in a source program or SPUFI input from an ISPF/PDF editor. To do this, specify a range of source lines to explain using the E line prefix command, then type EXPLAIN on the command line and press Enter. Any valid SQL statements within the specified range can then be selected from a list for Explain processing. For more information about source Explain, see [“ISPF Online Monitor Source Explain”](#) on page 141.

If Explain executed successfully, the Db2 Explain Output panel is displayed. For more information about the Db2 Explain Output panel, see [“Explain output \(Db2 Explain Output panel\)”](#) on page 139.

Explain Menu

Use the Explain Menu to specify the Db2 subsystem where the Explain request is to be performed (optional), a different SQL authorization ID for qualifying the unqualified tables in the statements being explained, and to select an option for explaining an SQL statement. To display the Explain Menu, select option 9 (Explain) from the Online Monitor Main Menu.

```

DGOMYPMN                                Explain Menu

Local location . . . . . : PMODB2A          SDA2  V10
Current server . . . . . : PMODB2A          SDA2  V10

Change current server if required, then select one of the following.

- 1. Explain an existing entry in the plan table
  2. Explain a package's SQL statement
  3. Explain a DBRM's SQL statement
  4. Enter an SQL statement to be explained

Current server . . . . . PMODB2A_____ +
Current SQLID . . . . . PMDEV51_____ +

Command ==> _____
F1=Help   F2=Split  F3=Exit   F9=Swap   F12=Cancel F21=Expand F22=Left
F23=Right

```

Figure 119. Explain Menu

Use the **Current server** field to specify the Db2 subsystem where you want the Explain request to be performed. This field makes it possible that you are connected to a Db2 test subsystem while you execute the Explain on the remote production system. The default value is the local location.

Use the **Current SQLID** field to specify a different SQL authorization ID for qualifying the unqualified tables in the SQL statements to be explained. The **Current SQLID** field can also be used to qualify the plan table to be accessed. The default value is your user ID.

Whenever package or DBRM SQL statements are explained, the package or plan qualifier is used to qualify unqualified SQL statements. The package or plan owner is used to qualify the plan table.

From this window, you can select one of the following options:

- Select option 1 (Explain an existing entry in the plan table) to display the Plan Table Entry window, where you can interpret an existing entry in your plan table, or in another user's plan table if you have the required Db2 authority.
- Select option 2 (Explain a package's SQL statement) to display the Package SQL Statement window, where you can explain an SQL statement for a previously bound package.
- Select option 3 (Explain a DBRM's SQL statement) to display the DBRM SQL Statement window, where you can explain an SQL statement for a previously bound plan.
- Select option 4 (Enter an SQL statement to be explained) to display the SQL Text Entry window, where you can explain a dynamic SQL statement. After you specified the query number, the SQL Text Edit panel is displayed, where you can enter and explain a dynamic SQL statement.

Use these options, and related windows, to select the SQL statement you want to explain. The SQL statement is then explained, and the result displayed in the Db2 Explain Output panel.

Explain existing entry in Plan Table

Use the Plan Table Entry window to explain an entry in your plan table or, if you have the required Db2 authority, an entry in another user's plan table. Regardless of the user specified, a Db2 plan table needs to exist for that user.

To display this window, select option 1 from the Explain Menu.

```

DGOMYWPE                               Plan Table Entry

Local location . . . . . : PMODB2A          SDA2  V10
Current server . . . . . : PMODB2A          SDA2  V10

Specify the owner of the plan table. Then either specify a
query number, or leave query number blank and enter plan,
program and version details for a list of query numbers.

Owner of plan table . . . . . PMDEV51_----- +
Query number . . . . . -----

Plan name . . . . . -----
Program name . . . . . : DGO@TPG1         +
Version . . . . . ----- +

Command ==> -----
F1=Help   F2=Split   F3=Exit   F9=Swap   F12=Cancel F21=Expand
F22=Left  F23=Right

```

Figure 120. Plan Table Entry window

Enter a user ID in the Owner of plan table field, or leave this field blank to specify your own plan table. Then specify the Query number of the plan table entry you want to explain.

If the 1 field is left blank, all entries are listed that match the plan name, program name, and version that you specified. Leaving any of these criteria fields blank is equivalent to specifying an asterisk (*), which matches all entries. The Plan Table Entry List panel is then displayed, which lists all matching entries in the plan table.

After selecting an entry in a plan table, the entry is processed and the result is shown in the Db2 Explain Output panel.

Plan Table Entry List panel

Use the Plan Table Entry List panel to select an entry from the list of entries belonging to the plan table. If many table entries are listed, you can use the scrolling keys F7 (Up) and F8 (Down) to browse the list.

```

DGOMYWPL                               Plan Table Entry List                               Row 1 to 5 of 5

Local location . . . . . : PMODB2A          SDA2  V10
Current server . . . . . : PMODB2A          SDA2  V10

Table . . . . . : PMDEV51.PLAN_TABLE        +

S      Query  Plan      Program      Version      Timestamp
-----+-----1-----+-----1-----+
_      1011001  DGO@TPG1    OMPE_FINAL   2011021615243488
_      1011001  DGO@TPG1    OMPE_FINAL   2011030811011901
_      1011001  DGO@TPG1    0510_PM32647C 2011092016072777
_      1011001  DGO@TPG1    0510_PM32647C 2012012413093911
_      1011001  DGO@TPG1    0510_PM32647C 2012012413101054
***** Bottom of data *****

Command ==> -----
F1=Help   F2=Split   F3=Exit   F7=Up      F8=Down    F9=Swap
F12=Cancel F16=Look   F17=Collect F21=Expand F22=Left   F23=Right

```

Figure 121. Plan Table Entry List panel

After making a selection, the entry is processed and the result is shown in the Db2 Explain Output panel.

Explain an SQL statement of a package

Use the Package SQL Statement window to explain an SQL statement of a previously bound package.

To display this window, select option 2 from the Explain Menu.

```

DGOMYWKS                Package SQL Statement
Collection identifier . . . . K02EX510_-----+
Package name . . . . . DGO@TPG*-----+
Version . . . . . -----+

Command ==> -----
F1=Help      F2=Split    F3=Exit     F9=Swap     F12=Cancel
F16=Look     F17=Collect F21=Expand  F22=Left    F23=Right

```

Figure 122. Package SQL Statement window

To explain an SQL statement from this window, type the collection identifier, package name, and version into the appropriate fields and press Enter. Wildcards are accepted in these fields. Empty fields are equivalent to asterisks (*), which is the default. The Package Version List panel is then displayed, where you can select a package from a list of all matching packages.

Package Version List panel

The Package Version List panel shows a list of packages that match the fields specified in the Package SQL Statement window. If many packages are listed, you can use the scrolling keys F7 (Up) and F8 (Down) to browse the list.

```

DGOMYWKV                Package Version List                Row 1 to 8 of 8
Local location . . . . . : PMODB2A                SDA2 V10
Current server . . . . . : PMODB2A                SDA2 V10

S  Collection          Package          Version
----+-----1-----2  ----+-----1-----2  ----+-----1-----2-----+
-  K02EX510            DGO@TPG1        OMPE_FINAL
-  K02EX510            DGO@TPG1        0510_PM32647C
-  K02EX510            DGO@TPG2        OMPE_FINAL
-  K02EX510            DGO@TPG2        0510_PM32647C
-  K02EX510            DGO@TPG3        0510_PM32647C
-  K02EX510            DGO@TPG4        0510_PM32647C
***** Bottom of data *****

Command ==> -----
F1=Help      F2=Split    F3=Exit     F7=Up       F8=Down     F9=Swap
F12=Cancel   F16=Look    F17=Collect F21=Expand  F22=Left    F23=Right

```

Figure 123. Package Version List panel

From this window, you can select a package to display the SQL Statement List panel, where you can examine a list of SQL statements belonging to the package.

SQL Statement List panel (Packages)

The SQL Statement List panel shows a list of SQL statements for the selected package. For each item listed, the statement number and the first 60 characters of the SQL statement text are shown. If many

SQL statements are listed, you can use the scrolling keys F7 (Up) and F8 (Down) to browse the list. Use the key F21 (Expand) to browse the SQL statement.

```

DGOMYWKQ                SQL Statement List                Row 1 to 7 of 7

Local location . . . . . : PMODB2A                SDA2  V10
Current server . . . . . : PMODB2A                SDA2  V10

Collection . . . . . : K02EX510                +
Package . . . . . : DG0@TPG1                +
Version . . . . . : 0510_PM32647C            +

S   Statement  SQL Statement Text
-----+-----1-----+-----2-----+-----3-----+-----4-----+-----5-----+-----6
-      36  DECLARE DGO_SYSPACKAGE TABLE ( LOCATION VARCHAR ( 128 ) NOT
-      1011001 SELECT LOCATION , COLLID , NAME , CONTOKEN , OWNER , CREATOR
-      1011002 SELECT LOCATION , COLLID , NAME , CONTOKEN , OWNER , CREATOR
-      1011003 SELECT DEGREE INTO :HV_SYSPACKAGE_DEGREE FROM DGO_SYSPACKAGE
-      1011051 SELECT LOCATION , COLLID , NAME , CONTOKEN , OWNER , CREATOR
-      1011052 SELECT LOCATION , COLLID , NAME , CONTOKEN , OWNER , CREATOR
-      1011053 SELECT DEGREE INTO :HV_SYSPACKAGE_DEGREE FROM DGO_SYSPACKAGE
***** Bottom of data *****

Command ==>
F1=Help      F2=Split    F3=Exit     F7=Up       F8=Down    F9=Swap
F12=Cancel   F16=Look    F17=Collect F21=Expand  F22=Left   F23=Right

```

Figure 124. SQL Statement List panel

From this window, you can select the SQL statement to be explained. The SQL statement is then processed and the result is shown in the Db2 Explain Output panel.

Explain an SQL statement of a DBRM

Use the DBRM SQL Statement window to explain an SQL statement of a previously bound plan.

To display this window, select option 3 from the Explain Menu.

```

DGOMYWDS                DBRM SQL Statement

DBRM name . . . . . DSN*_____ +
Plan name . . . . . _____

Command ==>
F1=Help      F2=Split    F3=Exit     F9=Swap     F12=Cancel
F16=Look    F17=Collect F21=Expand  F22=Left    F23=Right

```

Figure 125. DBRM SQL Statement window

To explain an SQL statement from this window, type the DBRM name and plan name into the appropriate fields and press Enter. Wildcards are accepted in these fields. Empty fields are equivalent to asterisks (*), which is the default. The DBRM and Plan List panel is then displayed, where you can select a DBRM from a list of all matching DBRMs and plans.

DBRM and Plan List panel

The DBRM and Plan List panel shows a list of DBRMs and plans matching the fields specified in the DBRM SQL Statement window. If many items are listed, you can use the scrolling keys F7 (Up) and F8 (Down) to browse the list.

```
DGOMYWDL                      DBRM and Plan List                      Row 1 to 4 of 4
Local location . . . . . : PMODB2A          SDA2  V10
Current server . . . . . : PMODB2A          SDA2  V10

S   DBRM                      Plan Name
----+-----1-----+-----2
-   DSNTIAD                    DSNTIA81
-   DSNTIAD                    DSNTIAD
-   DSNTIAUL                   DSNTIAUL
-   DSNTIAUL                   DSNTIB81
***** Bottom of data *****

Command ==> -----
F1=Help     F2=Split   F3=Exit    F7=Up      F8=Down    F9=Swap
F12=Cancel  F16=Look   F17=Collect F21=Expand F22=Left   F23=Right
```

Figure 126. DBRM and Plan List panel

From this window, you can select any DBRM listed to display the SQL Statement List panel, where you can examine a list of SQL statements belonging to the DBRM.

SQL Statement List panel (DBRMs)

The SQL Statement List panel shows a list of SQL statements for the selected DBRM. This window shows the statement number and the first 60 characters of the SQL statement text for each item listed. If many SQL statements are listed, you can use the scrolling keys F7 (Up) and F8 (Down) to browse the list. Use the key F21 (Expand) to browse the SQL statement.

```
DGOMYWDQ                      SQL Statement List                      Row 1 to 4 of 59
Local location . . . . . : PMODB2A          SDA2  V10
Current server . . . . . : PMODB2A          SDA2  V10

DBRM . . . . . : DSNTIAUL                    +
Plan name . . . . . : DSNTIAUL

S   Statement  SQL Statement Text
-----+-----1-----+-----2-----+-----3-----+-----4-----+-----5-----+-----6
-   724  DECLARE MSEL STATEMENT
-   935  WHENEVER SQLERROR GO TO EXECER11
-   8064 SELECT CURRENT SQLID INTO :CRNAME FROM SYSIBM . SYSDUMMY1
-   9162 ROLLBACK
***** Bottom of data *****

Command ==> -----
F1=Help     F2=Split   F3=Exit    F7=Up      F8=Down    F9=Swap
F12=Cancel  F16=Look   F17=Collect F21=Expand F22=Left   F23=Right
```

Figure 127. SQL Statement List panel

From this window, you can select an SQL statement to be explained. The SQL statement is then processed and the result is shown in the Db2 Explain Output panel.

Explain dynamic SQL statement

Use the SQL Text Entry window and its associated SQL Text Edit panel to enter an SQL statement to be explained.

To display this window, select option 4 from the Explain Menu.

```

DGOMYWES                                SQL Text Entry

Enter query number if needed, then press Enter to display the SQL Text
Edit panel.

  Query number . . . . . 999735912

  Set current degree to ANY

F1=Help   F2=Split   F3=Exit   F9=Swap   F12=Cancel

```

Figure 128. SQL Text Entry window

In this window, enter the query number you want to assign to the SQL statement. The query number identifies in the plan table the SQL statement that you are entering. If no query number is specified, the default is 999 735 912.

The 1 field specifies whether the SQL statement is eligible for query parallelism. If you enter a forward slash (/) in this field, the current degree of parallelism is set to ANY. Otherwise, the current degree of parallelism is set to 1.

After you press Enter, the Edit SQL Text panel is displayed, where you can enter the SQL statement text you want to explain.

SQL Text Edit panel

Use this panel to view or modify the full text of an SQL statement for purposes of online tuning, or to create an SQL statement to be explained.

This panel is displayed by pressing Enter in the SQL Text Entry window, or by selecting the 1 field from the Db2 Explain Output panel.

```

ISREDDE2   XRK.PM04.SPFTEMP1.CNTL           Columns 00001 00072
***** ***** Top of Data *****
000001 SELECT COUNT ( * ) INTO :HV_LOC10_COUNT FROM DGO_SYSPACKAGE WHERE
000002 LOCATION = :HV_LOC10_LOCATION AND ( COLLID LIKE :HV_LOC10_COLLID OR
000003 COLLID LIKE :HV_LOC10_COLLID2 ) AND ( NAME LIKE :HV_LOC10_NAME OR NAME
000004 LIKE :HV_LOC10_NAME2 ) AND VERSION LIKE :HV_LOC10_VERSION QUERYNO
000005 001011010
***** ***** Bottom of Data *****

Command ==>          Scroll ==> CSR_
F1=Help   F2=Split   F3=Exit   F5=Rfind   F6=Rchange   F7=Up
F8=Down   F9=Swap    F10=Left  F11=Right  F12=Cancel   F13=Help
F14=Split F15=End    F16=Return F17=Rfind  F18=Rchange  F19=Up
F20=Down  F21=Swap   F22=Left  F23=Right  F24=Cretriev

```

Figure 129. SQL Text Edit panel

From this panel, you can enter a new (or modify an existing) SQL statement to assess the effect on access path selection. The statement can be adjusted and then explained again to dynamically assess the effect.

You can enter SQL text that exceeds the display depth by using the scrolling keys F7 (Up) and F8 (Down).

To process and explain the entered SQL text, press F3 (Exit). The Db2 Explain Output panel is displayed with a confirmation message.

To ignore the changes and return to the previous panel, press F12 (Cancel).

Explain output (Db2 Explain Output panel)

Use the Db2 Explain Output panel and Catalog Table windows to investigate the access path methods of an explained SQL statement. Information regarding packages, DBRMs, table spaces, tables, indexes, and column attributes can also be viewed.

Use the Db2 Explain Output panel to examine the results of an explain request.

When an SQL statement has been chosen for explanation, the following processing depends on the origin of the statement:

Explain existing entry in the plan table

The specified PLAN_TABLE entry is shown as a result of the explain request.

Explain a package's SQL statement

The plan table of the package owner is searched to check whether the SQL statement has been explained during BIND. If the search is successful, this PLAN_TABLE entry is taken. If the search is not successful, a dynamic explain is performed, that is, SQL EXPLAIN is invoked for the statement. Then the result of this explain is displayed.

The plan table is searched by using the bind time of the package. There might be multiple occurrences of the package with different bind times. For example, the Db2 system catalog might contain the latest package that is created by the Db2 command BIND or REBIND. It might also contain a former package version that is activated by the Db2 command REBIND SWITCH.

Explain a DBRM's SQL statement

The plan table of the DBRM owner is searched to check whether the SQL statement has been explained during BIND. If the search is successful, this PLAN_TABLE entry is taken. If the search is not successful, a dynamic explain is performed, that is, SQL EXPLAIN is invoked for the statement. Then the result of this explain is displayed.

SQL statement to be explained has been entered

A dynamic explain is performed, that is, SQL EXPLAIN is invoked for the statement, and the result is displayed.

SQL statement is modified in Db2 Explain Output panel

A dynamic explain is performed, that is, SQL EXPLAIN is invoked for the modified statement and the new result is displayed.

Only the Db2 Explain Output panel for packages (DGOMYPKM) is shown in this section.

```

DGOMYPKM                DB2 Explain Output
Local location . . . . . : PMODB2A          SDA2  V10
Current server . . . . . : PMODB2A          SDA2  V10

_ Package . . . . . : K02EX510.DG0@TPG1      +
  Version . . . . . : 0510_PM32647C         +
  Explain executed at . . . : 12/01/25 18:33:56.63

----- SQL Text -----
_ SELECT LOCATION , COLLID , NAME , CONTOKEN , OWNER , CREATOR , TIMESTAMP
  , BINDTIME , QUALIFIER , PKSIZE , AVGSIZE , SYSENTRIES , VALID ,
  Status . : Compiled-bound using defaults for input variables
  Isolation: Uncommitted Read

_ Host variable definitions

----- Access path summary for query block 1 step 1 -----
Matching index scan with scan of referenced data pages
Number of matching columns: 4. The index has 4 columns
Non clustered index scan will be used
Page range scan will not be used

_ Table  SYSIBM  SYSPACKAGE
_ Index  SYSIBM  DSNKX01

_ PLAN_TABLE details for step

FPEM762 This statement was explained at bind time
Command ==> -----
F1=Help    F2=Split    F3=Exit    F7=Up      F8=Down    F9=Swap
F12=Cancel F16=Look    F17=Collect F21=Expand F22=Left   F23=Right

```

Figure 130. Db2 Explain Output panel (packages)

The Db2 Explain Output panel is divided into three sections:

- The first section of the panel shows the plan name, and information about the package or DBRM that contains the SQL statement. You can select this section for further investigation of the package, DBRM, or plan name associated with the SQL statement.
- The second section of the panel, titled `SQL Text`, shows the first 150 characters of the SQL statement text. You can view or modify the full SQL statement text by selecting the input field shown beside the SQL text. The SQL Text Edit panel is then displayed. For more information about the SQL Text Edit panel, see [“SQL Text Edit panel”](#) on page 139. After the SQL text is modified, the SQL statement is reexplained, and the new result is shown in the Db2 Explain Output panel. From this section you can also reach windows that provide information about the host variable definitions.
- The third section of the panel, titled `Access path summary`, shows information about the access path methods chosen by Db2 for each of the individual query blocks and steps required to execute the SQL statement. Each step also shows a list of the tables and indexes accessed for that step. You can select any table or index listed in a step for further investigation. You can also display the raw `PLAN_TABLE` data for a step. This also provides online access to help information for `PLAN_TABLE` columns, similar to the information in *Db2 SQL Reference* for the EXPLAIN statement.

If the execution of the SQL statement contains many steps, you can use the scrolling keys F7 (Up) and F8 (Down) to browse through the steps.

Online Monitor EXPLAIN command

Use the EXPLAIN command to explain the currently executing SQL statement in the Thread Activity panels.

- SQL Statement and Package
- SQL Statement and DBRM

Note: If the Thread Detail panel has been modified to show the SQL statement text, you can use the EXPLAIN command from the Thread Detail panel as well.

If the explain request was successful, the Db2 Explain Output panel is displayed.

The command syntax is:

►► EXPLAIN ◀◀

Figure 131. Syntax of the EXPLAIN command

Note: EXPLAIN can be truncated to a minimum of EXP.

For a description of the Db2 Explain Output panel, see [“Explain output \(Db2 Explain Output panel\)”](#) on page 139.

ISPF Online Monitor Source Explain

Use Source Explain to explain SQL statements that are embedded in a source program or SPUFI input. Source explain is performed from within the ISPF/PDF editor.

The following languages are supported:

- Assembler
- C
- COBOL
- FORTRAN
- PL/I
- SPUFI

Note: Ensure that Source Explain is installed at your site. Before you activate Source Explain, make sure that the Db2 load library is allocated to your TSO ISPF session.

To explain an SQL statement while editing a source program (or SPUFI input), specify the lines you want to have explained by using the ISPF/PDF editor line prefix command E, type EXPLAIN on the command line, and press Enter.

You can use the line prefix command E like this:

E

To explain a single line, type E in the prefix area of the line to be scanned for SQL statements.

EE

To explain a range of lines, type EE in the prefix area of the first line and the last line of the range of lines to be scanned for SQL statements.

E[n]

To explain a specific number of lines, type E[n] on the first line of the area to be scanned, where *n* is the number of lines to be scanned for SQL statements.

When you enter the EXPLAIN command, Source Explain scans the specified range for valid SQL statements. If a range is not specified, the entire source is scanned. The valid SQL statements are then listed on the SQL Statement Selection panel.

The following figure shows how to explain an SQL statement while editing COBOL source code.

To explain the SQL statements in the source code from line 3040 to 3160:

1. In the line prefix area of lines 3040 and 3160, type EE.
2. On the command line, type explain and press Enter.

```

EDIT ---- SYS1.DSN610.SDSNSAMP(DSNBBC3) - 01.00 ----- COLUMNS 001 072
003010      *** CURSOR LISTS ALL EMPLOYEE NAMES WITH A PATTERN (%) OR (_)
003020      *** FOR LAST NAME
003030
EE3040          EXEC SQL DECLARE TELE2 CURSOR FOR
003050              SELECT *
003060              FROM   VPHONE
003070              WHERE  LASTNAME LIKE :LNAME-WORK
003080                  AND  FIRSTNAME LIKE :FNAME-WORK
003090              END-EXEC.
003100
003110      *** CURSOR LISTS ALL EMPLOYEES WITH A SPECIFIC
003120      *** LAST NAME
003130
003140          EXEC SQL DECLARE TELE3 CURSOR FOR
003150              SELECT *
003160              FROM   VPHONE
003170              WHERE  LASTNAME = :LNAME
003180                  AND  FIRSTNAME LIKE :FNAME-WORK
003190              END-EXEC.
003200      /
003210      /*****
003220      * FIELDS SENT TO MESSAGE ROUTINE      *
003230      *****/
003240      01 MAJOR                PIC X(07) VALUE 'DSNBBC3'.
003250
003260      01 MSGCODE              PIC X(4).
COMMAND ==> explain          SCROLL ==> CSR
F1=HELP   F2=SPLIT   F3=END       F4=RETURN   F5=RFIND   F6=RCHANGE
F7=UP     F8=DOWN    F9=SWAP      F10=LEFT   F11=RIGHT  F12=RETRIEVE

```

Figure 132. Source Explain example

If you previously selected the **Always display this window** field in the Source Explain Options window as shown in [Source Explain Options window](#), the Source Explain Options window is displayed. If you did not select this field, the [SQL Statement Selection panel](#) is displayed.

Source Explain Options window

You can display the Source Explain Options window by specifying a command in the ISPF/PDF editor or on the SQL Statement Selection panel.

- In the command line of the ISPF/PDF editor, type EXPLAIN OPTIONS and press Enter.

If you have previously selected the **Always display this window** field in the Source Explain Options window, you can type EXPLAIN in the command line of the ISPF/PDF editor and press Enter.

- In the command line of the SQL Statement Selection panel, type OPTIONS and press Enter.

You can use the Source Explain Options window to specify the Source Explain processing options, for example, the language of the source code you are editing, the subsystem ID of the explaining Db2, the SQLID to be used, or the degree of parallelism.

```
DGOMYWSO          Source Explain Options
Update fields as required, then press Enter

Local DB2 subsystem . . . . . ----
Current server location . . . . . -----
Current SQLID . . . . . -----
Query number . . . . . -----

/ Set current degree to ANY
/ Always display this window

Define source language . . . . . _  1. Assembler
                                     2. C/370
                                     3. COBOL
                                     4. FORTRAN
                                     5. PL/I
                                     6. SPUFI

F1=Help   F2=Split   F3=Exit   F9=Swap   F12=Cancel
```

Figure 133. Source Explain Options window

On the Source Explain Options window, you can specify the following options:

Local Db2 Subsystem

The local Db2 subsystem to which you want to connect.

Current Server Location

The Db2 subsystem where you want the source SQL statements to be explained.

In this field, you can specify the Db2 test subsystem you want to connect to while you are executing the explain on the remote production system. If you do not specify a subsystem, the local Db2 subsystem is used.

Current SQLID

A different SQL authorization ID for qualifying the unqualified tables in the SQL statements being explained.

A different SQL authorization ID is also used to qualify the plan table to be accessed. If you do not specify an SQL authorization ID, your user ID is used.

Query number

A number that identifies the Explain statement.

If you do not specify a number, the value 999 735 912 is assigned to this field.

Set current degree to ANY

To specify whether the SQL statement is eligible for query parallelism.

By default, the current degree of parallelism is set to 1. To set the current degree of parallelism to ANY, type a slash (/) in this field.

Always display this window

To control the display of the Source Explain Options window.

By default, the Source Explain Options window is not displayed on each Source Explain request. To display the Source Explain Options window on each Source Explain request, type a slash (/) in this field.

All system parameter fields are supported. You can also use Query Workload Tuner.

Db2 System Parameters panel

Use the Db2 System Parameters panel to view a summary of important DSNZPARM values, maximum concurrent users, and IRLM thresholds. Use the scrolling keys F7 (Up) and F8 (Down) to view all information in the Db2 System Parameters panel.

To display the Db2 System Parameters panel, select option 3 (Display System Parameters) from the Online Monitor Main Menu.

The following figure shows the Db2 System Parameters panel.

```
DGOZPSM          DB2 System Parameters
Command ==>>>

For details, type any character next to heading, then press Enter.

PM05D851          D851  V10

- Data (DSNTIPA1, DSNTIPA2)
- Data Sharing Parameters (DSNTIPK)
- Sizes Panel 2(DSNTIP7)
- Thread Management(DSNTIPE)
- Buffer Pools (DSNTIP1, DSNTIP2, DSNTIP6)
- Tracing Parameters (DSNTIPN)
- Operator Functions (DSNTIPO)
- Application Programming Defaults 1(DSNTIPF)
- Application Programming Defaults 2(DSNTIP4)
- Performance and Optimization (DSNTIP8)
- IRLM (DSNTIPI, DSNTIPJ)
- IRLM Processing Parameters
- Protection (DSNTIPP)
- MVS Parmlib Updates (DSNTIPM)
- Active Log Data Set Parameters (DSNTIPL, DSNTIPH)
- Archive Log Data Set Parameters (DSNTIPA, DSNTIPH)
- Databases and Table Spaces (DSNTIPS)
- Distributed Data Facility (DSNTIPR, DSNTIP5)
- Routine Parameters (DSNTIPX)
- Data Definition Control Support (DSNTIPZ)
- Storage Sizes(DSNTIPC)
- Group Buffer Pools
- ZParm Online Change Auditing
- Other Parameters

F1=Help      F2=Split      F3=Exit      F6=History   F7=Up        F8=Down
F9=Swap      F12=Cancel   F16=Look    F17=Collect
```

Figure 136. Db2 System Parameters panel

Note: The Db2 System Parameters panel you see might have been tailored by your installation and consequently might not necessarily match the panel examples shown in this information.

From the Db2 System Parameters panel, you can reach a set of windows that provide system parameters information in greater detail. To reach a window, type any character in the space provided beside the heading.

Several windows can be accessed simultaneously by selecting multiple fields in the Db2 System Parameters panel. To leave the current window and proceed with the next window, press F3 (Exit). To cancel all windows and return to the Db2 System Parameters panel, press F12 (Cancel).

System Parameters commands

The following command applies to System Parameters panels. You can type the command on any System Parameters panel command line, or invoke it using the appropriate function key. A list of active function keys is displayed at the bottom of each panel. You can abbreviate commands down to three characters in length. For example, the HISTORY command can be abbreviated to HIS.

Problem identification examples

This section provides examples of how to discover and identify various system problems by using exception processing, viewing past data, analyzing the access paths chosen by Db2 to process an SQL statement, and viewing thread activity and statistics panels.

Example of exception processing

This example demonstrates how you can use exception processing to discover a possible class 2 CPU (processing) time problem, and identify the cause by viewing past data and analyzing the access paths chosen by Db2 to process an SQL statement. The data collector needs to be installed at your site to view past data.

First, set the exception threshold for class 2 CPU time to a value applicable to your environment. To do this, select option 8 (Maintain parameter data sets) from the Online Monitor Main Menu. This displays the Data Set Maintenance Menu.

```
DGOPMENU                Data Set Maintenance Menu
Select one of the following.
1  1. Maintain exception thresholds
   2. Maintain correlation translations
   3. Maintain time zone information
   4. Maintain MAINPACK definitions
Exception data set
'SAMPLE.EXCEPT.DATASET'
DPMPARMS data set
-----

Command ==> -----
F1=Help    F2=Split    F3=Exit    F6=History  F9=Swap    F12=Cancel
F17=Collect
```

Figure 137. Data Set Maintenance Menu

Ensure that you have specified an Exception Threshold data set name in the 1 field. Select option 1 (Maintain exception thresholds) to display the Exception Threshold Category Selection panel.

The Exception Threshold Category Selection panel is displayed.

```

DGOPXDS1      Exception Threshold Category Selection

Select one or more categories, then press Enter. Overtyping with space to
deselect any category. Request EXIT when complete.

  Category
/ Elapsed, CPU and Waiting Times per Plan Execution
- Elapsed, CPU and Waiting Times per Program Execution
- CPU Times per Address Space
- SQL Statements per Plan Execution
- SQL Statements per Program Execution
- SQL Statements per System
- Subsystem Events per Plan Execution
- Subsystem Events per System
- Locking Activity per Plan Execution
- Locking Activity per System
- RID List Processing per Plan Execution
- RID List Processing per System
- Query Parallelism per Plan Execution
- Query Parallelism per System
- Buffer Pools Activity per Plan Execution
- Buffer Pools Activity per System
- Distributed Activity per Location per Plan Execution

Command ==>-----
F1=Help   F2=Split  F3=Exit   F7=Up     F8=Down   F9=Swap   F12=Cancel

```

Figure 138. Exception Threshold Category Selection panel

Select the category that contains the exception field you want. For this example, select the Elapsed, CPU and Waiting Times per Plan Execution field.

The Exception Threshold Field Selection panel is displayed.

```

DGOPXDS2      Exception Threshold Field Selection

Select only one field, then press Enter. Overtyping with space to
deselect any field. Request EXIT when complete.

Field category . . : Elapsed, CPU, and Waiting Times per Plan Execution

  Field      Description
- ADRECETT   Elapsed time in application (Class 1)
- ADCPUT     CPU time in application (Class 1)
- ADDB2ETT   Elapsed time in DB2 (Class 2)
/ ADDBCPUT   CPU time in DB2 (Class 2)
- ADTWTDB    Total wait time in DB2 (Class 2)
- ADTWTAP    Total wait time in application (Class 1)
- ADTSUST    Total Class 3 suspensions time
- ADTSUSC    Total Class 3 suspensions
- QWACAWTL   Lock/latch suspensions time (Class 3)
- ADLLSUSC   Lock/latch suspensions (Class 3)
- QWACAWTI   Synchronous I/O susp. time (Class 3)
- ADIOSUSC   Synchronous I/O suspensions (Class 3)
- QWACAWTR   Other read I/O susp. time (Class 3)

Command ==>-----
F1=Help   F2=Split  F3=Exit   F7=Up     F8=Down   F9=Swap   F12=Cancel

```

Figure 139. Exception Threshold Field Selection panel

This panel shows all available fields within the specified category. Select the ADDBCPUT field and press Enter.

The Exception Threshold Field Details panel is displayed.

```

DGOPXDSN                Exception Threshold Field Details

                                                                ENTRY 1 OF 1

Category . . . . . : Elapsed, CPU, and Waiting Times per Plan Execution
Field ID . . . . . : ADDBCPUT
Description . . . . . : CPU time in DB2 (Class 2)

Active . . . . . 1 1=Yes 2=No

By . . . . . 1 1=Total 2=Minute 3=Second
                4=Commit 5=Thread

Compare operator . . > <=Less than >=Greater than
Warning threshold . . 0.09
Problem threshold . . 0.1

Local location . . . *
Group name . . . . . *
Member name . . . . . *
Subsystem ID . . . . . *
Requester location . . *
Connect . . . . . *
Planname . . . . . *
Corrname . . . . . *
Corrnbr . . . . . *
Primauth . . . . . *

Command ==>-----
F1=Help      F2=Split    F3=Exit     F5=Add      F6=Delete   F7=Up
F8=Down     F9=Swap     F10=Previous F11=Next    F12=Cancel

```

Figure 140. Exception Threshold Field Details panel

Use the Exception Threshold Field Details panel to specify the threshold criteria for the exception field selected from the Exception Threshold Field Selection panel. For this example, enter a 1 in the Active field, set the By field to Total (1), the Compare operator field to a greater than symbol (>), and the Problem threshold field to a value of 0.1 seconds.

Note: Choose a threshold value that is applicable to your environment. For information about defining exception threshold values, see [“How to define exception threshold values”](#) on page 35.

Now that the exception threshold has been defined, select option 5 (Control Exception Processing) from the Online Monitor Main Menu to display the Exception Processor panel.

```

DGOMEPO2                Exception Processor                PM01DLOC DSN1 V10

For any field enter any character to activate

Activate/Deactivate Exception Processing
- Display thread summary
- Display thread detail
- Display statistics detail
/ Periodic                - User Exit
- Exception event notification

Options
Periodic units . . . . . 1      1=Seconds
                                   2=Minutes
Periodic interval . . . . . 10  1-7200 Seconds
                                   1-120 Minutes

> Disable auto-display for problem exceptions
> Sound alarm for exception warnings
- Log file data set output needed
- DPMOUT data set output needed

Exception threshold data set
Name . . . . . SAMPLE.EXCEPT.DATASET

Command ==> -----
F1=Help      F2=Split    F3=Exit     F7=Up       F8=Down     F9=Swap
F12=Cancel   F16=Look    F17=Collect

```

Figure 141. Exception Processor panel

Use the Exception Processor panel to activate periodic exception processing. Enter the Exception Threshold data set name you specified on the Data Set Maintenance Menu and type a forward slash (/) in the Periodic field to activate periodic exception processing. In this example, the exception processor has been set to check for periodic exceptions every 10 seconds.

For more information about activating exception processing, see [“How to start exception processing” on page 35](#).

When a periodic exception occurs, the Online Monitor notifies you by displaying the Exception Notification window. This window is overlaid on the current panel.

```

DGOMTPSM 14:27                               Thread Detail                               PM01DLOC DSN1 V10
                                           GROUP001 MEMBER01
For details, place any character next to heading, then press Enter.
More: - +
- Thread Identification
  Primauth . . . . . : TFA6
  Planname . . . . . : CICSEMP      DGOMEPEX Exception Notification
  Connection ID . . . : APPCICP3
  Requesting Location: PM01DLOC   Time . . : 05/03/08 14:27:41
- Current Package . . . . .
- Times
  Class 1 . . . . . : Periodic Exceptions
  Class 2 . . . . . : Problem : 1
  Class 3 . . . . . : Warning : 0
  Class 7 . . . . . : F1=Help      F2=Split      F9=Swap
  Class 8 . . . . . : F12=Cancel
- Locking Activity
  Timeouts . . . . . : 0
  Deadlocks . . . . . : 0
  Suspensions . . . . : 1
  Lock escalations . . : 0
  Maximum page locks held . . . . : 9
- Locked Resources
- RID List Processing
  Unsuccessful - any reason . . . . . : 0
- SQL Activity, Commits and Rollbacks
  DML . . . . . : 4 Commit . . . . . : 0
  DCL . . . . . : 0 Rollback . . . . . : 0
  DDL . . . . . : 0 Changes/Commit . . . : 0.0
- Buffer Manager Activity
  Getpage requests . . . . . : 60
  Buffer updates . . . . . : 0
  Prefetch reads . . . . . : 1
  Synchronous I/O . . . . . : 0
  SQL Statement and Package . . . . . : EMPSRCH
- Distributed Data
  Requester elapsed time . . . . . : N/P
- IFI (Class 5) and Data Capture
- Query Parallelism Data
- Data Sharing Locking Activity
  Suspensions . . . . . : N/A
- Group Buffer Pools Activity
- Stored Procedures

Command ==> -----
F1=Help      F2=Split    F3=Exit     F5=Auto     F6=History  F7=Up
F8=Down      F9=Swap     F12=Cancel  F16=Look    F17=Collect F22=Purge

```

Figure 142. Exception Notification window (overlaid on Thread Detail panel)

The Exception Notification window indicates that a periodic exception has occurred. You can examine the exception in greater detail using the LOOK command. Type LOOK 1 on any command line and press Enter to display the Periodic Exceptions List window.

```

DGOMLAXP                Periodic Exceptions List                Row 499 to 500 of 500
Periodic Interval started . . . . . : 05/03/08 11:43:26:10
Last Interval . . . . . : 05/03/08 14:27:41:22

  Time      Location      Group  Subsystem  Member  Corname
  Field     Reqloc          Primauth  Planname  Connect  Corinmbr
  Descr
-----
- 14:27:41  PM01DLOC        GROUP001 DSN1      MEMBER01 TESTDC6
   'BLANK'   TFA6           CICSEMP   APPCICP3 'BLANK'

  ADDBCPUT 0.108004      >      0.1      Problem  Total
  CPU TIME IN DB2 (CLASS 2)

***** Bottom of data *****

Command ==>
  F1=Help   F2=Split   F3=Exit   F7=Up     F8=Down   F9=Swap
  F12=Cancel

```

Figure 143. Periodic Exceptions List window

From this window you can examine a list that contains the last 500 periodic exceptions that have occurred. The most recent exceptions are displayed at the bottom of the list.

In this example the thread causing the exception has ended. However, you can still select the exception to be examined from the list displayed in the Periodic Exceptions List window. If history and data collector are available, the Online Monitor retrieves past data and displays the Thread Detail panel where you can examine the thread causing the exception.

Some fields can have values that are longer than the space available to show them in this panel. When this happens, the last character in the field is replaced with an asterisk (*) to indicate that the reported value is truncated.

For details, place any character next to heading, then press Enter.

```

- Thread Identification
  Primauth . . . . . : TFA6           Correlation name . . . . . : TESTDC6
  Planname . . . . . : CICSEMP        Connection type . . . . . : CICS
  Connection ID . . . : APPCICP3       Type . . . . . : ALLIED
  Requesting Location: PM01DLOC       Status . . . . . : DB2
- Current Package . . . . . : EMPSRCH
- Times
  Class 1 . . . . . : 1:09:58.64058   Elapsed             CPU
  Class 2 . . . . . : 11.563398       0.593096
  Class 3 . . . . . : 6.186118        N/A
  Class 7 . . . . . : N/P             N/P
  Class 8 . . . . . : N/P             N/A
- Locking Activity
  Timeouts . . . . . : 0
  Deadlocks . . . . . : 0
  Suspensions . . . . . : 1
  Lock escalations . . . . . : 0
  Maximum page locks held . . . . . : 9
- Locked Resources
- RID List Processing
  Unsuccessful - any reason . . . . . : 0
- SQL Activity, Commits and Rollbacks
  DML . . . . . : 4 Commit . . . . . : 0
  DCL . . . . . : 0 Rollback . . . . . : 0
  DDL . . . . . : 0 Changes/Commit . . . . . : 0.0
- Buffer Manager Activity
  Getpage requests . . . . . : 60
  Buffer updates . . . . . : 0
  Prefetch reads . . . . . : 1
  Synchronous I/O . . . . . : 0
/ SQL Statement and Package . . . . . : EMPSRCH
  Distributed Data
  Requester elapsed time . . . . . : N/P
- IFI (Class 5) and Data Capture
- Query Parallelism Data
- Data Sharing Locking Activity
  Suspensions . . . . . : N/A
- Group Buffer Pools Activity
- Stored Procedures

Command ==> -----
F1=Help      F2=Split    F3=Exit     F5=Auto     F6=History  F7=Up
F8=Down      F9=Swap     F12=Cancel  F16=Look    F17=Collect
F22=Purge
  
```

Figure 144. Thread Detail panel

The word HISTORY is displayed under the heading line of the Thread Detail panel to indicate that you are viewing past data. The date and time displayed next to HISTORY represent the time just after the exception occurred.

This is where you can use past data to examine the data on a thread that has ended. In this way, you can examine the thread before and after the exception occurred by moving backward and forward through time. See [“Viewing past data” on page 30](#) for more information about viewing past data.

Because class 2 time is the time spent within Db2, the excessive class 2 time causing the exception could be caused by a possible SQL statement problem.

From the Thread Detail panel, select SQL Statement and Package to display the SQL Statement and Package window.

```

DGOMTWCS          SQL Statement and Program
                                HISTORY 00/05/08 14:27:41
                                More: +
_ SQL Statement : SELECT * FROM SYSIBM.SYSTABLES WHERE CREATOR='POD'

Location . . . . . : PM01D711
Collection ID . . . . . : DSNESPCS
Program name . . . . . : DSNESM68
Nested activity name . . . . . : N/P
Program type . . . . . : Package
Consistency token . . . . . : X'149EEA901A79FE48'
Version
N/P
Statement type . . . . . : CLOSE
Statement number . . . . . : 0
Current SQL ID . . . . . : POD
Bind type . . . . . : Dynamic
Cached dynamic SQL identifier . . . : N/A
Thread status . . . . . : In DB2
Database name . . . . . : N/P
Page set name . . . . . : N/P
Page number . . . . . : N/P
Elapsed time . . . . . : N/P
CPU time . . . . . : N/P
_ Used Buffer Pools
  Getpages . . . . . : N/P
  Synch read I/O . . . . . : N/P

Command ==> -----
F1=Help      F2=Split    F3=Exit     F5=Auto     F6=History
F7=Up        F8=Down     F9=Swap     F12=Cancel  F16=Look
F17=Collect  F18=Explain F22=Purge

```

Figure 145. SQL Statement and Package window

This window displays the SQL statement executing at the time the exception occurred. To obtain details about the access paths chosen by Db2 to process the SQL statement, press F18 (Explain) to explain the SQL statement and display the Db2 Explain Output panel.

```

DGOMYPKM          DB2 Explain Output
                                More - +

Local location . . . . . : PM01DL0C          DSN1 V10
Current server . . . . . : PM01DL0C          DSN1 V10

_ Package . . . . . : EMPLOYEE.EMPSRCH
Version . . . . . : EMPSRCH_PACKAGE_VERSION1

Explain executed at . . . . : 13:10:52 04/17/08

----- SQL Text -----
_ SELECT EMPNO, LASTNAME, WORKDEPT, BIRTHDATE FROM DSNB710.EMP WHERE
EMPNO = :EMPLOYEE_NUMBER
Status : Compiled-REPORT specified. Rebound at exec.time using values
Isolation: Cursor stability

_ Host variable definitions

----- Access path summary for query block 1 step 1 -----
Table space scan - no index will be used
Standard sequential prefetch will be performed
Lock mode is share lock for the page
Page range scan will not be used

/ Table DSNB710 EMP

_ PLAN_TABLE details for step

----- Access path summary for query block 1 step 2 -----
Command ==> -----
F1=Help      F2=Split    F3=Exit     F7=Up        F8=Down     F9=Swap
F12=Cancel   F16=Look    F17=Collect

```

Figure 146. Db2 Explain Output panel (packages)

The access path summary in the Db2 Explain Output panel shows that a table space scan is being used to access the table. This could indicate the reason for the excessive class 2 time.

Select the table from the Db2 Explain Output panel to display the Table Information window, where you can see if any indexes have been defined for the table.

```

DGOMYWTI                Table Information
Local location . . . . . : PM01DLOC          DSN1 V10
Current server  . . . . . : PM01DLOC          DSN1 V10
More:           - +
Table name . . . . . : DSNB710.EMP
Type . . . . . : TABLE
/ Indexes . . . . . : YES
Database name . . . . . : DSNBD31A
_ Table space name . . . . . : DSNBS31E
Table identifier . . . . . : 14
Columns . . . . . : 14
Rows . . . . . : 32
Status . . . . . : HAS PRIMARY INDEX
Maximum record length . . . . . : 107
Pages . . . . . : 1
Percentage of pages used . . . . . : 2
Last RUNSTATS . . . . . : 04/13/08 10:53:27
EDIT procedure name . . . . . : DSNBEAE1
VALIDATION procedure . . . . . : NONE
Auditing . . . . . : NONE
DATA CAPTURE option . . . . . : NONE
Row compression . . . . . : 0
Alias table or view . . . . . :
Check constraints . . . . . : 0
Encoding scheme . . . . . : EBCDIC

Command ==>
F1=Help   F2=Split  F3=Exit   F7=Up     F8=Down   F9=Swap
F12=Cancel F16=Look  F17=Collect

```

Figure 147. Table Information window

From this window you can see that an index has been defined for the table. Select Indexes to display the Index Selection window where you can select the index to be examined. In this example, the index selected is DSNB710.XEMP1. This displays the Index Information window.

```

DGOMYWII                Index Information
Local location . . . . . : PM01DLOC          DSN1 V10
Current server  . . . . . : PM01DLOC          DSN1 V10
More:           - +
_ Index name . . . . . : DSNB710.XEMP1
Index space name . . . . . : XEMP1
Table name . . . . . : DSNB710.EMP
Database name . . . . . : DSNBD31A
Buffer pool . . . . . : BPO
/ Key columns . . . . . : 1
Subpage size (bytes) . . . . . : 512
Unique rule . . . . . : PRIMARY - UNIQUE
Clustering index . . . . . : YES
Currently clustered . . . . . : YES
Cluster ratio . . . . . : 100
Full key card . . . . . : 32
First key card . . . . . : 32
Levels . . . . . : 1
Leaf pages . . . . . : 1
Maximum piece size (KB) . . . . . : 256
Close rule . . . . . : LEAVE OPEN
Last RUNSTATS . . . . . : 04/13/08 10:53:27
Allocated space . . . . . : 0
Erase rule . . . . . : NO
Index type . . . . . : 2
Time of CREATE INDEX . . . . . : 2008-01-27-08.12.59.000000
Time of last ALTER INDEX . . . . . : 2008-01-27-10.22.30.000000

Command ==>
F1=Help   F2=Split  F3=Exit   F7=Up     F8=Down   F9=Swap
F12=Cancel F16=Look  F17=Collect

```

Figure 148. Index Information window

From the Index Information window, you can select Key columns to display the Key Column Information window.

```

DGOMYWCI                Key Column Information

Local location . . . . . : PM01DLOC          DSN1 V10
Current server  . . . . . : PM01DLOC          DSN1 V10
                                           More:  - +

Column name . . . . . : EMPNO
Table name . . . . . : DSNB710.EMP
Index name . . . . . : DSNB710.XEMP1
Position . . . . . : 6
Sequence . . . . . : Ascending
Type . . . . . : CHAR
Length . . . . . : 6
Scale . . . . . : 0
Key cardinality . . . . . : 123
Null value . . . . . : No
Second highest value . . . . . : 200330
Second lowest value . . . . . : 000020
Last RUNSTATS . . . . . : 2008-04-13-13.10.33.103784

_ Show Key Distribution values

Command ==>
F1=Help      F2=Split    F3=Exit     F7=Up       F8=Down
F9=Swap      F12=Cancel   F16=Look    F17=Collect

```

Figure 149. Key Column Information window

Use this window to examine the characteristics of the key column on which the index has been defined.

One of the possible reasons for an index not being used is that the host variable defined in the program does not match the characteristics of the column as defined in the table. To determine whether this is the reason for the index not being used, you can return to the Db2 Explain Output panel where the Host Variable Definition window can be selected.

```

- Host Variable Definition -
DGOMYWVHV

Local location . . . . . : PM01DLOC          DSN1 V10
Current server  . . . . . : PM01DLOC          DSN1 V10

Name                                     Type                               Length
EMPLOYEE_NUMBER                          FIXED CHARACTER                      8

Command ==>
F1=Help      F2=Split    F3=Exit     F7=Up       F8=Down    F9=Swap
F12=Cancel   F16=Look    F17=Collect

```

Figure 150. Host Variable Definition window

In this particular example, the Host Variable Definition window shows that the definitions do not match, thereby disqualifying use of the index.

The host variable defined in the source program should be changed to match the table definition so that Db2 can use the index and thereby reduce the class 2 time.

Example of thread monitoring

This example demonstrates how to identify a possible lock suspension problem using the Online Monitor thread activity function.

Display the Thread Summary panel by selecting option 1 (Display Thread Activity) from the Online Monitor Main Menu.

```

DGOMTPLS 13:49          Thread Summary          ROW 1 TO 5 OF 5
PM01DLOC          DSN1 V10  GROUP001 MEMBER01

To display a thread, place any character next to it, then press Enter.

  Primauth  Planname  Program  Connection  Status  Class 1  Class 2
-  SYSADM   K02PLAN  SYSADM   DB2CALL    APPL    37:30.3691  1.2797744
-  USERT001 K02PLAN  USERT001 DB2CALL    APPL    19:06.9127  0.6458763
-  USERT001 DSNESPRR USERT001 TSO        APPL    30:10.7428  0.9713783
-  USERT002 K02PLAN  USERT002 DB2CALL    DB2     46:25.5780  1.5100349
-  USERT003 DSNESPCS USERT003 TSO        DB2     31.4012740  0.9831031
-- End of Thread list --

Command ==> -----
F1=Help      F2=Split    F3=Exit     F5=Auto     F6=History  F7=Up
F8=Down      F9=Swap     F10=Qualify F11=Sort    F12=Cancel  F16=Look
F17=Collect  F19=Left   F20=Right   F22=Purge

```

Figure 151. Thread Summary panel

Note: To view Class 3 times in the Thread Summary panel, you need to scroll the display to the right (F20).

Type SORT on the command line and press Enter to display the Db2 Thread Sort Specification window, where you can sort threads by class 3 lock/latch times in descending sequence so that threads with the most time spent waiting because of lock and latch suspensions are sorted to the top.

```

DGOMTWSS          DB2 Thread Sort Specification

Specify field order by number in range 1 to 15. Enter 1 for Ascending or
2 for Descending sequence.

Column              Order              Sequence          More:  - +
Prim Auth  . . . . .  --              -
Plan Name  . . . . .  --              -

Package/DBRM
  Collection ID . . . . .  --              -
  Program Name . . . . .  --              -

Correlation . . . . .  --              -
Connection ID . . . . .  --              -
Connection type . . . . .  --              -
Requesting location . . . . .  --              -
Thread status . . . . .  --              -
Request count . . . . .  --              -

Class 1 times
  Elapsed . . . . .  --              -
  CPU . . . . .  --              -

Class 2 times
  Elapsed . . . . .  --              -
  CPU . . . . .  --              -

Class 3 time . . . . .  1_              2

Command ==> -----
F1=Help      F2=Split    F3=Exit     F7=Up       F8=Down     F9=Swap
F12=Cancel   F16=Look   F17=Collect

```

Figure 152. Db2 Thread Sort Specification window

You can also sort threads by class 3 lock/latch times in descending sequence by typing the command SORT C3E and pressing Enter on the command line.

For information about the SORT command see [“SORT command”](#) on page 87.

Press F3 (Exit) to exit the Db2 Thread Sort Specification window and return to the Thread Summary panel.

```

DGOMTPLS 13:54          Thread Summary  SORT          ROW 1 TO 5 OF 5
PM01DLOC          DSN1 V10  GROUP001 MEMBER01

To display a thread, place any character next to it, then press Enter.

  Primauth  Planname  Program      Connection      ----- Elapsed -----
 / USERT003  DSNESPCS  USERT003     TSO             LOCK           2:43.66156     1:11.85677
- USERT001  K02PLAN  USERT001     DB2CALL        APPL           19:06.9123     0.6458763
- USERT001  DSNESPRR  USERT001     TSO             APPL           30:10.7424     0.9713783
- USERT002  K02PLAN  USERT002     DB2CALL        DB2            46:25.5787     1.5100349
- SYSADM    K02PLAN  SYSADM       DB2CALL        APPL           37:30.369      1.2797744
-- End of Thread list --

Command ==> -----
F1=Help      F2=Split    F3=Exit      F5=Auto      F6=History   F7=Up
F8=Down      F9=Swap     F10=Qualify  F11=Sort     F12=Cancel   F16=Look
F17=Collect  F19=Left   F20=Right   F22=Purge

```

Figure 153. Thread Summary panel

At this point, all threads have been sorted in descending sequence by class 3 lock/latch time, although this field is not displayed. You can press the F20 (Right) key to view class 3 times. The word SORT is displayed in the header of the Thread Summary panel.

For example, to view detailed information about the class 3 lock and latch times of a particular thread, type any character next to that thread and press Enter. The Thread Detail panel is displayed.

Note: The Thread Detail panel that you see might have been tailored by your installation and consequently might not necessarily match the panel examples shown in this information.

```

DGOMTPSM 13:58          Thread Detail          PM01DLOC DSN1 V10
                          GROUP001 MEMBER01
For details, place any character next to heading, then press Enter.

- Thread Identification
  Primauth . . . . . : USERT003          Correlation name . . . . . : USERT003
  Planname . . . . . : DSNESPCS          Connection type . . . . . : TSO
  Connection ID . . . . . : TSO           Type . . . . . : ALLIED
  Requesting Location: DSNAPC6          Status . . . . . : LOCK
  Current Package . . . . . : DSNESM68
7 Times
  Class 1 . . . . . : 2:44.363291        CPU
  Class 2 . . . . . : 1:11.856771        0.088226
  Class 3 . . . . . : 1:04.192452        0.041806
  Class 7 . . . . . :                    N/A
  Class 8 . . . . . :                    N/A
- Locking Activity
  Timeouts . . . . . : 0
  Deadlocks . . . . . : 0
  Suspensions . . . . . : 2
  Lock escalations . . . . . : 0
  Maximum page locks held . . . . . : 6
- Locked Resources
- RID List Processing
  Unsuccessful - any reason . . . . . : 0

Command ==> -----
F1=Help      F2=Split    F3=Exit      F5=Auto      F6=History   F7=Up
F8=Down      F9=Swap     F12=Cancel   F16=Look     F17=Collect
F22=Purge

```

Figure 154. Thread Detail panel

The Thread Detail panel shows that the thread is in LOCK status. Select the 1 field to display the Thread Times window, where you can examine the suspension time shown in the Locks and latches field.

```

DGOMTWRL                Threads Holding Resource                ROW 1 TO 2 OF 2

To display a new thread, place any character next to it, then press Enter.
The Thread Detail will be displayed.

Database . . . . . : MACBP2DB   Object . . . : MACBP2TB
Resource type . . . . . : PAGESET   Resource . . . : N/A

      Primauth      Corname      Status      Subsystem
      Planname      Connection      Suspended      Duration
-   USERT001      USERT001      S            N/P
-   DSNESPRR      TSO            NO           COMMIT
-   USERT003      USERT003      N/A         N/P
      DSNESPCS      TSO            YES         COMMIT
***** BOTTOM OF DATA *****

Command ==>
F1=Help      F2=Split      F3=Exit      F5=Auto      F6=History    F7=Up
F8=Down      F9=Swap       F12=Cancel   F16=Look     F17=Collect   F22=Purge

```

Figure 157. Threads Holding Resource window (Planname)

All threads involved in the locking of this resource are displayed. From this window, it can be seen that USERT001 is causing USERT003 to be suspended. This problem can be resolved if USERT001 uses the SPUFI cursor stability plan (DSNESPSCS), as does USERT003, instead of the SPUFI repeatable read plan (DSNESPRR). You should decide whether it is necessary for USERT001 to use DSNESPRR, or if DSNESPSCS can be used instead.

Using the ISPF Online Monitor in deadlock resolution

A deadlock is an error condition where processing cannot continue because of an unresolved contention for a particular resource. A deadlock is signaled when the deadlock detection cycle time has been reached. Ensure that the resource timeout limit is at least twice that of the deadlock detection cycle so that deadlocks are detected before a timeout occurs.

Deadlock detection

Start the data collector to collect deadlock events.

Start exception event processing from the Exception Processor panel to be notified when an exception event occurs. See [“How to start exception processing”](#) on page 35.

Deadlock resolution

On detection of a deadlock, use LOOK to display the participants in the deadlock.

```

DGOMLEDD0                                Deadlock Data                                More:  - +
IFCID . . . . . : 172

Number of resources involved in deadlock : 2
Deadlock interval counter . . . . . : 2
Time deadlock detected . . . . . : 21:38:34.15

Locked resource
Type . . . . . : Datapage
Database . . . . . : 271      Object : 6
Page # . . . . . : X'3001F1'

Blocker
Member/DBMS identifier . . . . . : MEMBER01
Plan name . . . . . : DDL3P18
Correlation identifier . . . . . : RUNPRG18

Connection identifier . . . . . : BATCH
LUW identifier . . . . . : USIBMSY.SY10BDB2.A74AB9FEF91C
State . . . . . : EXCLUSIVE
Duration . . . . . : COMMIT
Status . . . . . : WAIT

Waiter
Member/DBMS identifier . . . . . : MEMBER02
Plan name . . . . . : DDL3P15
Correlation identifier . . . . . : RUNPRG15
Connection identifier . . . . . : BATCH
LUW identifier . . . . . : USIBMSY.SY30BDB2.A74AB9EE117F
Requested function . . . . . : LOCK
State . . . . . : UPDATE
Duration . . . . . : MANUAL
DB2 assigned worth value . . . . . : 18

Command ==> -----
F1=Help      F2=Split    F3=Exit     F7=Up       F8=Down
F9=Swap      F12=Cancel

```

Figure 158. Deadlock Data window

If the 1 field is Datapage, ensure that all applications (Holder and Waiter) access the resource in the same order.

If the deadlock concerns an index with high insert activity (the Locked resource Type field is Index Page), set the SUBPAGES parameter for the index to 1 or consider converting the index to type 2. If the problem is not related to SUBPAGES, it could be that the commit frequency for an update application is too low. The ratio of updates per commit can be viewed in the Thread Detail panel.

Application development and capacity planning

You can also use OMEGAMON XE for Db2 PE in application development and capacity planning.

The Explain and the SQL Activity reports can help you anticipate how an application will perform. The Online Monitor Explain and Source Explain functions as well as some functions of thread activity can assist you in tuning your application's SQL online.

Accounting and Statistics reports that are ordered by INTERVAL are useful in capacity planning. Use these reports to identify peak periods in system activity as well as the need to adjust system resources. monitoring Db2 subsystems

Chapter 4. Understanding common errors

This section describes problems often encountered when you use OMEGAMON XE for Db2 PE. If you come across a problem, read this section before contacting IBM service.

STEPLIB missing from IRF-generated JCL

Symptom

The STEPLIB DD statement is missing from the Interactive Report Facility-generated JCL.

Probable Cause

Wrong option selected while running FPEJVARs.

Explanation

FPEJVARs is an EXEC provided with OMEGAMON XE for Db2 PE that displays a panel for setting up certain defaults. One of the options in this panel specifies whether the OMEGAMON XE for Db2 PE load library is in the system LNKST concatenation. If this option is selected, no STEPLIB DD statement is in the IRF-generated JCL.

Command not found

Symptom

Message IKJ56500I Command xxx not found is issued during the execution of OMEGAMON XE for Db2 PE.

Probable Cause

The Program Control Facility (PCF) was not updated with the list of OMEGAMON XE for Db2 PE modules that are started as TSO command processors.

Explanation

The PCF performs a security check on all commands to examine if they are included in the PCF command list. See your system administrator to ensure that all necessary updates have been made. After the list has been updated, the commands can be used.

If you are running the ACF2 security program, the Command Limiting Table needs to be updated by adding FPEFMAIN, FPEMMAIN, and FPEF000.

Insufficient storage to display thread activity information

Symptom

Message FPEM103 Insufficient storage available for thread processing or message FPEM546 The area for handling all IFCID records is not large enough. V1 IFCID records are suppressed is issued when one of the Thread Activity panels is invoked.

Probable Cause

Insufficient storage allocated to hold all active thread information.

Explanation

By default, the Online Monitor allocates at least 1 MB of storage to hold active thread information. If the amount of active threads grows, more storage might become necessary. Use the Options panel, option 7 (ISPF Online Monitor Memory Usage) and allocate a larger storage area. See [“Options” on page 8](#) for more information. The new size is kept in member FPEFPROF of the ISPF profile data set (parameter IFIRALEN) and becomes active when the Online Monitor is restarted.

STEPLIB missing from IRF-generated JCL

Symptom: The STEPLIB DD statement is missing from the Interactive Report Facility-generated JCL.

Probable Cause: Wrong option selected while running FPEJVARs.

Explanation: FPEJVARs is an EXEC provided with OMEGAMON XE for Db2 PE that displays a panel for setting up certain defaults. One of the options in this panel specifies whether the OMEGAMON XE for Db2 PE load library is in the system LNKLST concatenation. If this option is selected, no STEPLIB DD statement is in the IRF-generated JCL.

Chapter 5. Additional Information

These topics provide additional information that can be helpful when you work with OMEGAMON XE for Db2 PE or OMEGAMON XE for Db2 PE.

Online Monitor field table

The tables in this section provide a list of the Online Monitor thread activity fields, statistics fields, and system parameters fields.

You can use these tables to cross-reference exception field names for display exception processing and for periodic exception processing, or to look up a field help panel name when customizing Online Monitor panels.

Field name	Field description	Help panel name	Exception
ABCLSPR	Prefetch Reads	DGO0231	Yes
ABCRWIO	Synchronous I/O	DGO0232	
ADRGPRIO	Getpage/Synchronous Reads	DGO0233	Yes
QBACDPF	Dynamic Prefetch Requests	DGO0222	
QBACGET	Getpage Requests	DGO0217	Yes
QBACIMW	Synchronous Writes	DGO0226	Yes
QBACLPF	List Prefetch Requests	DGO0221	
QBACPID	Buffer Pool ID	DGO0215	
QBACRIO	Synchronous Read I/O	DGO0219	Yes
QBACSEQ	Sequential Prefetch Requests	DGO0220	
QBACSIIO	Asynchronous Pages Read	DGO0229	
QBACSWs	Buffer Updates	DGO0225	Yes

Field name	Field description	Help panel name	Exception
ADIFICAL	IFI Calls	DGO0775	Yes
QIFAAIET	Class 5 Elapsed Time	DGO0202	Yes
QIFAAITT	Class 5 TCB Time	DGO0203	Yes
QIFAAMBT	Describe Time	DGO0204	
QIFAAMLT	Log Extraction Time	DGO0205	
QIFAANDD	Data Descriptions Returned	DGO0211	
QIFAANDR	Data Rows Returned	DGO0210	
QIFAANLR	Log Reads Performed	DGO0207	
QIFAANMB	Describes Performed	DGO0212	

Table 10. Accounting - Data Capture Activity and Class 5 Times (continued)

Field name	Field description	Help panel name	Exception
QIFAANRC	Log Records Captured	DGO0208	
QIFAANRR	Log Records Returned	DGO0209	
QIFAANTB	Tables Returned	DGO0213	

Table 11. Accounting - Data Sharing Locking Activity

Field name	Field description	Help panel name	Exception
ABUFFRAT	Buffer Pool Hit Ratio (%)	DGO1769	
AGLOBRAT	Global Contention Rate (%)	DGO1767	
QTGACPLK	Change Requests	DGO1399	
QTGACSLM	Change Requests - XES	DGO1402	
QTGADRTA	Incompatible Retained Lock	DGO1408	Yes
QTGAFLSE	Suspensions - False Contention	DGO1407	
QTGAIGLO	Suspensions - IRLM Global Contention	DGO1403	
QTGALPLK	Lock Requests	DGO1397	
QTGALSLM	Lock Requests - XES	DGO1400	
QTGANTFY	Notify Messages Sent	DGO1409	
QTGASGLO	Suspensions - XES Global Contention	DGO1406	
QTGAUPLK	Unlock Requests	DGO1398	
QTGAUSLM	Unlock Requests - XES	DGO1401	

Table 12. Accounting - Distributed Data Facility Activity

Field name	Field description	Help panel name	Exception
ADDSCNVC	Current DDF Conversions	DGO0270	
ADDSELSR	Remote Elapsed	DGO0263	Yes
ADDSSRSR	Remote CPU	DGO0264	Yes
ADPROTOC	Method	DGO0235	
QLACLOCN	Remote Location	DGO0234	
QW0148CT	Type	DGO0833	
QW0148EL	Requester Elapsed	DGO1195	Yes
QW0148MR	Messages Received	DGO0272	
QW0148MS	Messages Sent	DGO0271	
QW0148PT	Product ID	DGO0804	
QW0148PV	Product Version	DGO1556	

Table 12. Accounting - Distributed Data Facility Activity (continued)

Field name	Field description	Help panel name	Exception
QW01488A	Conversation Active Flag	DGO0266	
QW01488C	Conversation ID	DGO0269	
QW01488L	Remote Location	DGO0836	
QW01488N	Network Connection Type	DGO1722	
QW01488S	Connection ID	DGO0268	
QW01488T	Time of Last Message	DGO0267	
QW01488U	State	DGO0265	

Table 13. Accounting - Group Buffer Pools Activity

Field name	Field description	Help panel name	Exception
ABGAMR	Read (Not Found)-No Data Returned	DGO1832	Yes
ABGAXR	Read (Cross Inval.)-No Data Returned	DGO1833	Yes
QBGADG	Unregister Page	DGO1721	
QBGAGN	Group Buffer Pool ID	DGO1579	
QBGAMD	Read (Not Found) - Data Returned	DGO1413	Yes
QBGAMN	Read Prefetch	DGO1415	Yes
QBGASW	Changed Pages Written	DGO1418	Yes
QBGAWC	Clean Pages Written	DGO1417	Yes
QBGAXD	Read (Cross Invalidation) - Data Returned	DGO1410	Yes

Table 14. Accounting - Locking Activity

Field name	Field description	Help panel name	Exception
ALCLKET	Lock Escalations	DGO0190	Yes
ALRSUSLL	Number of Lock and Latch Suspensions	DGO0179	Yes
ALRSUSP	Total Suspensions	DGO0178	Yes
QTXACHG	Change Requests	DGO0186	
QTXACLNO	Claim Requests	DGO0192	
QTXACLUN	Unsuccessful Claim Requests	DGO0193	Yes
QTXADEA	Deadlocks	DGO0176	Yes
QTXADRNO	Drain Requests	DGO0194	
QTXADRUN	Unsuccessful Drain Requests	DGO0195	Yes
QTXAIRLM	Other IRLM Requests	DGO0187	
QTXALES	Lock Escalations - shared	DGO0188	Yes

Table 14. Accounting - Locking Activity (continued)

Field name	Field description	Help panel name	Exception
QTXALEX	Lock Escalations - Exclusive	DGO0189	Yes
QTXALOCK	Lock Requests	DGO0183	
QTXANPL	Maximum Page or Row Locks Held	DGO0191	Yes
QTXAQRY	Query Requests	DGO0185	
QTXASLAT	Suspensions - Latch	DGO0181	
QTXASLOC	Suspensions - Lock	DGO0180	Yes
QTXASOTH	Suspensions - Other	DGO0182	
QTXATIM	Timeouts	DGO0175	Yes
QTXAUNLK	Unlock Requests	DGO0184	
T3ANCHOR	Anchor	DGO1840	
T3BPID	Buffer pool Id	DGO1845	
T3COLL	Collection ID	DGO0842	
T3CONST	Consistency Token	DGO0843	
T3DBNAME	Database	DGO0844	
T3DURAT	Duration	DGO0845	
T3FUNCT	Function	DGO0846	
T3HASH	Hash Class	DGO1843	
T3LOCKS	Count	DGO0847	
T3OBNAME	Object	DGO0848	
T3PACK	Package ID	DGO0849	
T3PAGE	Page	DGO1837	
T3PART	Partition	DGO1844	
T3PLAN	Plan ID	DGO0850	
T3PLLCK	Attribute	DGO1792	
T3RMID	Resource Manager Id	DGO1842	
T3ROW	Row	DGO1839	
T3STATE	Status	DGO0851	
T3SUBP	Subpage	DGO1838	
T3SUSP	Suspended	DGO0852	
T3TYPE	Type	DGO0853	
T3UID	Utility UID	DGO1841	
T5SUBS	Subsystem	DGO1815	

Table 15. Accounting - Package Data

Field name	Field description	Help panel name	Exception
ADALPSSC	Archive Log (quiesce)	DGO0720	
ADARPSSC	Other Read I/O - Events	DGO0711	Yes
ADAWPSSC	Other Write I/O	DGO0714	Yes
ADCMPSSC	Claim Release	DGO0726	
ADCPCL7T	CPU Time (Class 7) - Par.Tasks - Tot.Exec.	DGO1631	
ADCPCL8T	Suspension Time (Class 8) - Parallel Tasks	DGO1665	
ADCPUTP	CPU Time (Class 7) - Total Execution	DGO1432	Yes
ADDRPSSC	Drain Lock	DGO0723	
ADELCL7C	Elapsed Time (Class 7) - Current Execution	DGO0697	
ADGCPSSC	Global Contention - Suspensions	DGO1381	
ADIOPSSC	Synchronous I/O - Events	DGO0708	Yes
ADLLPSSC	Locks and Latches - Events	DGO0705	Yes
ADLRPSSC	Archive Log Read	DGO0732	
ADNACL7T	Not Accounted	DGO0738	
ADNOPSSC	Notify Messages - Suspensions	DGO1378	
ADPGPSSC	Page Latch	DGO0729	
ADSPSSC	Stored Procedures - Suspensions	DGO1389	
ADSTPSSC	Services Task Switch	DGO0717	Yes
ADTCBCL8	Suspension Time (Class 8) - TCB	DGO1664	
ADTCCL7L	TCB Time Spent In Db2	DGO0700	
ADTSUSCP	Suspensions (Class 8) - Events	DGO0735	Yes
ADTSUSTP	Suspension Time (Class 8)	DGO0736	Yes
ADWTCL7T	Waiting Time - Total Execution	DGO1666	Yes
QPACALOG	Archive Log (quiesce)	DGO0721	
QPACARNA	Db2 Entry/Exit Events	DGO0810	
QPACAWAR	Archive Log Read	DGO0733	
QPACAWCL	Claim Release	DGO0727	
QPACAWDR	Drain Lock	DGO0724	
QPACAWTE	Services Task Switch	DGO0718	Yes
QPACAWTG	Notify Messages - Time	DGO1377	
QPACAWTI	Synchronous I/O - Elapsed Time	DGO0709	Yes
QPACAWTJ	Global Contention - Time	DGO1380	
QPACAWTL	Locks and Latches - Elapsed Time	DGO0706	Yes
QPACAWTP	Page Latch	DGO0730	

Table 15. Accounting - Package Data (continued)

Field name	Field description	Help panel name	Exception
QPACAWTR	Other Read I/O - Elapsed Time	DGO0712	Yes
QPACAWTW	Other Write I/O	DGO0715	Yes
QPACCAST	Stored Procedures - Time	DGO1388	
QPACCOLN	Collection ID	DGO0696	
QPACCONT	Consistency Token	DGO0694	
QPACLOCN	Location	DGO0692	
QPACPKID	Program Name	DGO0693	
QPACSCT	Elapsed Time (Class 7) - Total Execution	DGO0699	Yes
QPACSQLC	SQL Statements Issued	DGO0695	Yes
QPACTJST	CPU Time TCB - Class 7- Total Execution	DGO0701	

Table 16. Accounting - Query Parallelism

Field name	Field description	Help panel name	Exception
ADPARDIS	Parallelism Disabled by RLF	DGO1637	
ADPARLEV	Parallelism	DGO1596	
ADTOTPFL	Fall Back To Sequential Mode	DGO0684	Yes
AXXCRAT	Member Skipped (%)	DGO1783	
QXCOORNO	One Db2 COORDINATOR Parm = NO	DGO1680	
QXDEGBUF	Fall Back To Sequential Mode - No Buffer	DGO0683	Yes
QXDEGCUR	Fall Back To Sequential Mode - Cursor	DGO0774	Yes
QXDEGESA	Fall Back To Sequential Mode - No ESA	DGO0682	Yes
QXISORR	One Db2 Isolation Level	DGO1681	
QXMAXDEG	Maximum Degree of Parallelism	DGO0171	Yes
QXNORGRP	Planned Parallel Degree	DGO0174	
QXREDGRP	Reduced Parallel Degree	DGO0173	Yes
QXTOTGRP	Parallel Groups Executed	DGO0773	

Table 17. Accounting - RID List Processing

Field name	Field description	Help panel name	Exception
ARTTERM	Unsuccessful - Any Reason	DGO0170	Yes
QXMIAP	Successful	DGO0167	
QXMRMIAP	Not Used - Limit Exceeded	DGO0169	Yes
QXNSMIAP	Not Used - No Storage	DGO0168	Yes

Table 18. Accounting - SQL Activity (DML, DCL, DDI)

Field name	Field description	Help panel name	Exception
ADTDDL	Total DDL	DGO0166	Yes
ASCDCL	Total DCL	DGO0137	Yes
ASCDML	Total DML	DGO0122	Yes
ASRIUDCA	Changes/Commit	DGO0127	Yes
ASTOTALT	Number of Alter Statements Executed	DGO0165	
ASTOTCRT	Total	DGO0163	
ASTOTDRP	Total	DGO0164	
QW0124SP	Stored Procedure	DGO1846	
QW01482T	SQL Statement	DGO1863	
QXALDAB	Alter Database	DGO0155	
QXALOCC	Allocate Cursor	DGO1720	
QXALOCL	Associate Locators	DGO1719	
QXALTIX	Alter Index	DGO0149	
QXALTST	Alter Stogroup	DGO0152	
QXALTTA	Alter Table	DGO0143	
QXALTTS	Alter Tablespace	DGO0146	
QXCALLAB	Procedure Abends	DGO1392	Yes
QXCALLRJ	Call Statements Rejected	DGO1394	Yes
QXCALLTO	Call Statement Timeouts	DGO1393	Yes
QXCLOSE	Close	DGO0121	
QXCMTON	Comment On	DGO0139	
QXCON1	Connect Type 1	DGO0133	
QXCON2	Connect Type 2	DGO0134	
QXCRALS	Create Alias	DGO0160	
QXCRDAB	Create Database	DGO0153	
QXCRGTT	Create Temp. Table	DGO1654	
QXCRINX	Create Index	DGO0147	
QXCRSTG	Create Stogroup	DGO0150	
QXCRSYN	Create Synonym	DGO0156	
QXCRTAB	Create Table	DGO0141	
QXCTABS	Create Tablespace	DGO0144	
QXDEFVU	Create View	DGO0158	
QXDELET	Delete	DGO0115	
QXDESC	Describe	DGO0116	

Table 18. Accounting - SQL Activity (DML, DCL, DDI) (continued)

Field name	Field description	Help panel name	Exception
QXDRPAL	Drop Alias	DGO0161	
QXDRPDB	Drop Database	DGO0154	
QXDRPIX	Drop Index	DGO0148	
QXDRPPKG	Drop Package	DGO0162	
QXDRPST	Drop Stogroup	DGO0151	
QXDRPSY	Drop Synonym	DGO0157	
QXDRPTA	Drop Table	DGO0142	
QXDRPTS	Drop Tablespace	DGO0145	
QXDRPVU	Drop View	DGO0159	
QXDSCRTB	Describe Table	DGO1626	
QXFETCH	Fetch	DGO0120	
QXGRANT	Grant	DGO0129	
QXINSRT	Insert	DGO0113	
QXLABON	Label On	DGO0140	
QXLOCK	Lock Table	DGO0128	
QXOPEN	Open	DGO0119	
QXPREP	Prepare	DGO0118	
QXREL	Release	DGO0135	
QXREVOK	Revoke	DGO0130	
QXRNTAB	Rename Table	DGO1851	
QXSELECT	Select	DGO0112	
QXSETCDG	Set Current Degree	DGO0772	
QXSETCON	Set Connection	DGO0136	
QXSETCRL	Set Current Rules	DGO1390	
QXSETHV	Set Host Variable	DGO0132	
QXSETSQL	Set Current SQLID	DGO1627	
QXUPDTE	Update	DGO0114	
RDISTNUM	Statement Number	DGO0837	
RDISTYPE	Statement Type	DGO0838	
TCONTOK	Consistency Token	DGO0839	
TPACKAGE	Package Name	DGO0840	
TPKGDBRM	DBRM Being Executed	DGO0841	
TVERSION	Version	DGO0855	
T4STMT	SQL Statement	DGO0854	

Table 19. Accounting - SQL Nested Activity

Field name	Field description	Help panel name	Exception
QXCALL	SQL Call	DGO1391	

Table 20. Accounting - Termination Conditions, Commit/Rollback, Incremental Binds

Field name	Field description	Help panel name	Exception
ADCICSIN	CICS Token Instance	DGO0016	
ADCICSLU	CICS Token LU Name	DGO0015	
ADCICSNI	CICS Token Network ID	DGO0014	
ADCORNMB	Correlation Number	DGO0008	
ADCORNME	Correlation Name	DGO0007	
ADTHRSTA	Thread Status	DGO0033	
ADHRTYP	Thread Type	DGO0050	
QMDAACCT	MVS Accounting Token	DGO0019	
QMDAAPPL	Client Application Name	DGO1552	
QMDAASTR	Accounting String	DGO0029	
QMDAATID	Client Authid	DGO1553	
QMDAAUTH	Primauth	DGO0024	
QMDACNAM	Connection ID	DGO0827	
QMDACORR	Correlation ID	DGO0028	
QMDACTYP	Connection Type	DGO0025	
QMDALOCN	Location	DGO0021	
QMDALUNM	LU Name	DGO0023	
QMDANETN	Network ID	DGO0022	
QMDAPLAN	Plan Name	DGO0828	
QMDAPLAT	Client Platform	DGO1551	
QMDAPTYP	Product ID	DGO0020	
QMDAPVER	Product Version	DGO1555	
QMDASUFEX	DDCS Accounting Suffix	DGO1550	
QWACABRT	Rollback	DGO0058	Yes
QWACCOMM	Commit	DGO0057	Yes
QWACNID	Recovery Token	DGO0829	
QWHCAID	Primauth	DGO0006	
QWHCATYL	Connection Type	DGO0830	
QWHCATYP	Conntype	DGO0013	

Table 20. Accounting - Termination Conditions, Commit/Rollback, Incremental Binds (continued)

Field name	Field description	Help panel name	Exception
QWHCATYS	Connection Type	DGO0831	
QWHCCN	Connection ID	DGO0010	
QWHCCV	Correlation ID	DGO0009	
QWHCOPID	Origauth	DGO0012	
QWHCPLAN	Planname	DGO0011	
QWHCTOKN	RRSAF Accounting Token	DGO1737	
QWHDPTYP	Product ID	DGO0018	
QWHDPVER	Product Version	DGO1554	
QWHDRQNM	Requesting Location	DGO0017	
QWHSLOCN	Reporting Location	DGO0001	
QWHSLUCC	LUW Sequence Number	DGO0800	
QWHSLUNM	LUW LU Name	DGO0798	
QWHSLUUV	LUW Instance Number	DGO0799	
QWHSNID	LUW Network ID	DGO0797	
QW0148RQ	Request Count	DGO0034	
QXINCRB	Incremental Bind	DGO0059	Yes
QXSTDEXP	Cache Limit Exceeded	DGO1806	
QXSTDINV	Prepare Statement Purged	DGO1807	
QXSTFND	Prepare Statement Match	DGO1802	
QXSTIPRP	Implicit Prepare	DGO1804	
QXSTNFND	Prepare Statement No Match	DGO1803	
QXSTNPRP	Prepare from Cache	DGO1805	
QXSTREOP	Reoptimization	DGO1801	

Table 21. Accounting - Timing Data (Elapsed, TCB. Suspensions, and so on)

Field name	Field description	Help panel name	Exception
ADALSUSC	Archive Log (Quiesce) - Event	DGO0092	
ADARSUSC	Other Read I/O - Event	DGO0083	Yes
ADAWSUSC	Other Write I/O - Event	DGO0086	Yes
ADCMSUSC	Claim Release - Event	DGO0098	
ADCPCL3T	Suspension Time Par. Tasks - Class 3	DGO1668	
ADCPUPLL	CPU Time Parallel Tasks - Class 1	DGO1629	
ADCPUT	CPU Time - Class 1 in Application	DGO1425	Yes

Table 21. Accounting - Timing Data (Elapsed, TCB, Suspensions, and so on) (continued)

Field name	Field description	Help panel name	Exception
ADDBCPC2	CPU Time Parallel Tasks - Class 2	DGO1636	
ADDBCPUT	CPU Time - Class 2 in Db2	DGO1426	Yes
ADDBSRBT	Class 2 SRB Time	DGO0070	
ADDBTCBT	CPU Time TCB - Class 2 in Db2	DGO0068	
ADDB2ETT	Elapsed Time - Class 2 in Db2	DGO0066	Yes
ADDRSUSC	Drain Lock - Event	DGO0095	
ADDSTOTT	Requester Elapsed Time	DGO0825	Yes
ADGCSUSC	Global Contention - Event	DGO1376	
ADIOSUSC	Synchronous I/O - Event	DGO0079	Yes
ADLLSUSC	Locks and Latches - Event	DGO0076	Yes
ADLRSUSC	Archive Log Read - Event	DGO0688	
ADNOSUSC	Notify Messages - Event	DGO1374	
ADNOTACC	Not Accounted - Class 2 in Db2	DGO0107	
ADPGSUSC	Page Latch - Event	DGO0803	
ADRECETT	Elapsed Time - Class 1 in Application	DGO0063	Yes
ADSPSUSC	Stored Procedures - Event	DGO1387	
ADSRBT	Class 1 SRB Time	DGO0065	
ADSTSUSC	Services Task Switch - Event	DGO0089	Yes
ADTCBCL3	Suspension Time TCB - Class 3 in Db2	DGO1667	
ADTCBT	CPU Time TCB - Class 1	DGO1580	
ADTSRBOD	SRB Time Outside Db2	DGO0071	
ADTSUSC	Suspensions (Class 3) - Event	DGO0104	Yes
ADTSUST	Suspension Time (Class 3)	DGO0105	Yes
ADTTCBOD	CPU Time TCB - Outside Db2	DGO0069	
ADTTOTOD	Elapsed Time - Outside Db2	DGO0067	
ADTWTAP	Waiting Time - Class 1 in Application	DGO0072	Yes
ADTWTDB	Waiting Time - Class 2 in Db2	DGO0073	Yes
ADTWTODB	Waiting Time - Outside Db2	DGO0074	
QWACALOG	Archive Log (Quiesce) - Time	DGO0093	
QWACARNA	Db2 Entry/Exit - Non Stored Procedures	DGO0075	
QWACAWAR	Archive Log Read - Time	DGO0689	
QWACAWCL	Claim Release - Time	DGO0099	
QWACAWDR	Drain Lock - Time	DGO0096	
QWACAWTE	Services Task Switch - Time	DGO0090	Yes

Table 21. Accounting - Timing Data (Elapsed, TCB, Suspensions, and so on) (continued)

Field name	Field description	Help panel name	Exception
QWACAWTG	Notify Messages - Time	DGO1373	
QWACAWTI	Synchronous I/O - Time	DGO0081	Yes
QWACAWTJ	Global Contention - Time	DGO1375	
QWACAWTL	Locks and Latches - Time	DGO0077	Yes
QWACAWTP	Page Latch - Time	DGO0102	
QWACAWTR	Other Read I/O - Time	DGO0084	Yes
QWACAWTW	Other Write I/O - Time	DGO0087	Yes
QWACCAST	Stored Procedures - Time	DGO1386	
QWACSPCP	CPU Time TCB Stored Proc - Class 1 in Applic.	DGO1383	
QWACSPNE	Db2 Entry/Exit - Stored Procedures	DGO1385	
QWACSPPT	CPU Time TCB Stored Proc - Class 2 in Db2	DGO1384	

Table 22. Statistics - Authorization Management

Field name	Field description	Help panel name	Exception
QTAUCCH	Authorization Succ. W/o Catalog Access	DGO0460	
QTAUCHK	Authorization Attempts	DGO0458	
QTAUPUB	Authorization Successful Public Plan	DGO0461	
QTAUSUC	Authorization Successful	DGO0459	
QTPACAUT	Package Authorization Management - Successful	DGO1774	
QTPACNOT	P. A. M. Unsuccessful - Catalog Required	DGO1776	
QTPACOW1	P. A. M. - Overwritten Authid in Cache	DGO1777	
QTPACOW2	P. A. M. - Overwritten in Cache	DGO1778	
QTPACPUB	P. A. M. - Successful Public	DGO1775	

Table 23. Statistics - Buffer Pool Activity

Field name	Field description	Help panel name	Exception
QBSTCBA	Current Active Buffers	DGO0331	Yes
QBSTDIO	Dynamic Prefetch Reads	DGO0359	Yes
QBSTDMC	DM Critical Threshold Reached	DGO0376	Yes
QBSTDPF	Dynamic Prefetch Requested	DGO0358	Yes
QBSTDPP	Dynamic Prefetch Pages Read	DGO0360	Yes
QBSTDSO	Successful Data Set Opens	DGO0335	Yes
QBSTDWT	Deferred Write Threshold Reached	DGO0373	Yes

Table 23. Statistics - Buffer Pool Activity (continued)

Field name	Field description	Help panel name	Exception
QBSTDWV	Thresholds Reached - Vertical Deferred Write	DGO0374	Yes
QBSTGET	Getpage Request Total	DGO0343	
QBSTIMW	Synchronous Writes	DGO0370	Yes
QBSTJIS	Pref. I/O Streams - Reduced - Buffer Shortage	DGO0384	Yes
QBSTLIO	List Prefetch Reads	DGO0355	Yes
QBSTLPF	List Prefetch Requested	DGO0354	Yes
QBSTLPP	List Prefetch Pages Read	DGO0356	Yes
QBSTMAX	Not Created - No Buffer	DGO0394	Yes
QBSTMIG	DFHSM Migrated Data Sets	DGO0336	Yes
QBSTNGT	Unsuccessful Page Requests	DGO1862	
QBSTPID	Buffer Pool ID	DGO0330	
QBSTPIO	Sequential Prefetch Reads	DGO0351	Yes
QBSTPL1	Prefetch Quantity Reduced To 1/2	DGO0387	Yes
QBSTPL2	Prefetch Quantity Reduced To 1/4	DGO0388	Yes
QBSTPQF	Reduced Parallel Query Requests	DGO0386	Yes
QBSTPQO	Parallel Query Requests	DGO0385	
QBSTPWS	Pages Written	DGO0368	Yes
QBSTREE	Prefetch Disabled No Read Engine	DGO0363	Yes
QBSTRIO	Synchronous Reads Total	DGO0346	Yes
QBSTRPI	Page-ins Required for Read I/O	DGO0815	Yes
QBSTRTO	DFHSM Recall Timeouts	DGO0337	Yes
QBSTSEQ	Sequential Prefetch Requested	DGO0350	Yes
QBSTSGT	Getpage Request Sequential Access Only	DGO0344	
QBSTSIO	Synchronous Reads Sequential Access Only	DGO0347	Yes
QBSTSPD	Prefetch Disabled No Buffer	DGO0362	Yes
QBSTSPP	Sequential Prefetch Pages Read	DGO0352	Yes
QBSTSWS	Buffer Updates	DGO0367	Yes
QBSTVPA	Alter Buffer Pool Expansions and Contractions	DGO0341	Yes
QBSTVPL	Buffers Allocated for Virtual Buffer Pool	DGO0339	
QBSTWBVQ	Pages Not Written	DGO0398	Yes
QBSTWDRP	Pages Marked To Destruct	DGO0397	Yes
QBSTWFD	Workfile Request Rejected - Low Buffers	DGO0392	Yes
QBSTWFF	Degraded - Low Buffers	DGO0391	Yes
QBSTWFM	Maximum Concurrent Work Files	DGO0389	Yes

Table 23. Statistics - Buffer Pool Activity (continued)

Field name	Field description	Help panel name	Exception
QBSTWFR	Merge Passes Requested	DGO0390	
QBSTWFT	Requested for All Merge Pass	DGO0393	
QBSTWIO	Asynchronous Writes	DGO0371	Yes
QBSTWKPD	Prefetch Not Scheduled - Zero Quantity	DGO0396	Yes
QBSTWPI	Page-ins Required for Write I/O	DGO0816	Yes
QBSTXFL	Buffer Pool Full	DGO0333	Yes
QBSTXFV	Virtual Storage Unavailable	DGO0334	Yes
QBSTXIS	Prefetch I/O Streams, Concurrent Str. - HWM	DGO0383	Yes
SBRBUPW	Buffer Updates / Pages Written	DGO0369	
SBRBUTP	Virtual Buffer Pool Pages in Use (%)	DGO0805	Yes
SBRGPRI0	Getpage per Synchronous Read Random	DGO0349	
SBRPPRI0	Seq. Prefetch Pages Read / Seq. Prefetch Read	DGO0353	
SBRPWWIO	Pages Written per Write I/O	DGO0372	
SDDPPPIO	Dynamic Prefetch Pages Read / Dyn. Pref. Read	DGO0361	
SDGETRAN	Getpage Request - Random	DGO0345	
SDLPPPIO	List Prefetch Pages Read / List Prefetch Read	DGO0357	
SDSTRAN	Synchronous Reads - Random	DGO0348	Yes

Table 24. Statistics - Data Capture Activity

Field name	Field description	Help panel name	Exception
QWSDCDDD	Data Descriptions Returned	DGO0634	
QWSDCDDR	Data Rows Returned	DGO0632	
QWSDCDLC	Log Records Captured	DGO0629	
QWSDCDLR	Log Reads Performed	DGO0630	
QWSDCDMB	Describes Performed	DGO0633	
QWSDCDRR	Log Records Returned	DGO0631	
QWSDCDTB	Tables Returned	DGO0635	

Table 25. Statistics - Data Sharing Locking Activity

Field name	Field description	Help panel name	Exception
QTGSCHNP	P-lock Negotiation - Change	DGO1335	
QTGSCPLK	P-locks - Change Requests	DGO1319	
QTGSCSLM	Synchronous XES - Change Requests	DGO1321	

Table 25. Statistics - Data Sharing Locking Activity (continued)

Field name	Field description	Help panel name	Exception
QTGSDRTA	Incompatible Retained Lock	DGO1327	Yes
QTGSFLSE	Suspensions - False Contention	DGO1326	
QTGSIGLO	Suspensions - IRLM Global Contention	DGO1324	
QTGSKIDS	Asynchronous XES - Resources	DGO1323	
QTGSLPLK	P-locks - Lock Requests	DGO1317	
QTGSLSLM	Synchronous XES - Lock Requests	DGO1320	
QTGSNTFR	Notify Messages Received	DGO1329	
QTGSNTFY	Notify Messages Sent	DGO1328	
QTGSOTPE	P-lock Negotiation - Other	DGO1334	
QTGSPEMX	P-Lock/Notify Exists - Maximum Engines	DGO1330	
QTGSPEQW	P-locks/Notify Exists - Engines Unavailable	DGO1331	Yes
QTGSPGPE	P-lock Negotiation - Page	DGO1333	
QTGSPPE	P-lock Negotiation - Pageset/Partition	DGO1332	
QTGSSGLO	Suspensions - Global Contention	DGO1325	
QTGSUPLK	P-locks - Unlock Requests	DGO1318	
QTGSUSLM	Synchronous XES - Unlock Requests	DGO1322	
SBUFFRAT	Buffer Pool Hit Ratio (%)	DGO1772	
SGLOBRAT	Global Contention Rate (%)	DGO1770	

Table 26. Statistics - Db2 Application Programming Interface

Field name	Field description	Help panel name	Exception
QWSDSCA	Abends	DGO0583	Yes
QWSDSCCO	Command Requests	DGO0585	
QWSDSCRA	READA Requests	DGO0586	
QWSDSCRS	READS Requests	DGO0587	
QWSDSCU	Unrecognized	DGO0584	
QWSDSCWR	WRITE Requests	DGO0588	
SDIFITOT	Total number of calls made to IFI	DGO0589	Yes

Table 27. Statistics - Db2 Commands

Field name	Field description	Help panel name	Exception
Q9STCTRA	Stop Db2	DGO0552	
Q9STCTRB	Term Utility	DGO0557	

Table 27. Statistics - Db2 Commands (continued)

Field name	Field description	Help panel name	Exception
Q9STCTRC	Display Trace	DGO0539	
Q9STCTRD	RESET GENERICCLU	DGO1545	
Q9STCTRE	Start RLIMIT	DGO0548	
Q9STCTRF	Stop RLIMIT	DGO0553	
Q9STCTRG	DISPLAY RLIMIT	DGO0540	
Q9STCTRH	Modify Trace	DGO0555	
Q9STCTRI	Start DDF	DGO0549	
Q9STCTRJ	Stop DDF	DGO0554	
Q9STCTRK	Cancel DDF Thread	DGO0556	Yes
Q9STCTRL	Display Location	DGO0541	
Q9STCTRM	Archive Log	DGO0561	
Q9STCTRN	Alter Bufferpool	DGO0544	Yes
Q9STCTRO	Display Bufferpool	DGO0543	
Q9STCTRP	Set Archive	DGO0562	
Q9STCTRQ	Display Archive	DGO0542	
Q9STCTRR	Reset Indoubt	DGO0560	
Q9STCTRS	ALTER GROUPBUFFERPOOL	DGO1361	Yes
Q9STCTRT	DISPLAY GROUPBUFFERPOOL	DGO1360	
Q9STCTRU	DISPLAY PROCEDURE	DGO1456	
Q9STCTRV	START PROCEDURE	DGO1457	
Q9STCTRW	STOP PROCEDURE	DGO1458	
Q9STCTRX	DISPLAY GROUP	DGO1544	
Q9STCTR0	Display Database	DGO0536	
Q9STCTR1	Display Thread	DGO0537	
Q9STCTR2	Display Utility	DGO0538	
Q9STCTR3	Recover BSDS	DGO0558	
Q9STCTR4	Recover Indoubt	DGO0559	
Q9STCTR5	Start Database	DGO0545	
Q9STCTR6	Start Trace	DGO0546	Yes
Q9STCTR7	Start Db2	DGO0547	
Q9STCTR8	Stop Database	DGO0550	
Q9STCTR9	Stop Trace	DGO0551	
Q9STEROR	Unrecognized Commands	DGO0563	
SDSTTOTL	Total number of Db2 commands issued	DGO0564	Yes

Table 28. Statistics - Db2 Destination Data

Field name	Field description	Help panel name	Exception
SDIGTFNW	GTF Not Written	DGO0596	
SDIGTFRA	GTF Not Accepted	DGO0597	
SDIGTFWF	GTF Write Failure	DGO0598	
SDIGTFWR	GTF Written	DGO0595	
SDIOP1NW	OP1 Not Written	DGO0600	
SDIOP1RA	OP1 Not Accepted	DGO0601	
SDIOP1WR	OP1 Written	DGO0599	
SDIOP2NW	OP2 Not Written	DGO0603	
SDIOP2RA	OP2 Not Accepted	DGO0604	
SDIOP2WR	OP2 Written	DGO0602	
SDIOP3NW	OP3 Not Written	DGO0606	
SDIOP3RA	OP3 Not Accepted	DGO0607	
SDIOP3WR	OP3 Written	DGO0605	
SDIOP4NW	OP4 Not Written	DGO0609	
SDIOP4RA	OP4 Not Accepted	DGO0610	
SDIOP4WR	OP4 Written	DGO0608	
SDIOP5NW	OP5 Not Written	DGO0612	
SDIOP5RA	OP5 Not Accepted	DGO0613	
SDIOP5WR	OP5 Written	DGO0611	
SDIOP6NW	OP6 Not Written	DGO0615	
SDIOP6RA	OP6 Not Accepted	DGO0616	
SDIOP6WR	OP6 Written	DGO0614	
SDIOP7NW	OP7 Not Written	DGO0618	
SDIOP7RA	OP7 Not Accepted	DGO0619	
SDIOP7WR	OP7 Written	DGO0617	
SDIOP8NW	OP8 Not Written	DGO0621	
SDIOP8RA	OP8 Not Accepted	DGO0622	
SDIOP8WR	OP8 Written	DGO0620	
SDIRTTWR	RES Written	DGO0623	
SDISMFBF	SMF Buffer Overrun	DGO0593	Yes
SDISMFNW	SMF Not Written	DGO0591	
SDISMFRA	SMF Not Accepted	DGO0592	
SDISMFWF	SMF Write Failure	DGO0594	
SDISMFWR	SMF Written	DGO0590	

Table 28. Statistics - Db2 Destination Data (continued)

Field name	Field description	Help panel name	Exception
SDTOTNA	Total number of IFC records not accepted	DGO0626	Yes
SDTOTNW	Total number of IFC records not written	DGO0625	Yes
SDTOTW	Total number of IFC records succ. written	DGO0624	Yes
SDTOTWF	Total number of IFC write failures	DGO0628	Yes

Table 29. Statistics - Db2 Instrumentation

Field name	Field description	Help panel name	Exception
SDBSCRNW	System Parameters - Buffer Pools	DGO0578	
SDBSCRW	System Parameters - Buffer Pools	DGO0577	
SDIACTN	Accounting (not written)	DGO0570	
SDIACTW	Accounting (written)	DGO0569	
SDIAUDN	Audit (not written)	DGO0580	
SDIAUDW	Audit (written)	DGO0579	
SDIDRRN	Database Related (not written)	DGO0568	
SDIDRRW	Database Related (written)	DGO0567	
SDISRRN	System Related (not written)	DGO0566	
SDISRRW	System Related (written)	DGO0565	
SDISTPN	Stop Trace (not written)	DGO0574	
SDISTPW	Stop Trace (written)	DGO0573	
SDISTRN	Start Trace (not written)	DGO0572	
SDISTRW	Start Trace (written)	DGO0571	
SDIZPMN	Dsnzparm (not written)	DGO0576	
SDIZPMW	Dsnzparm (written)	DGO0575	
SDTSCRNW	Total count of all Db2 records not written	DGO0582	Yes
SDTSCRW	Total count of all Db2 records written	DGO0581	Yes

Table 30. Statistics - Distributed Data Facility - per Location

Field name	Field description	Help panel name	Exception
QLSTABRR	Rollbacks Received	DGO0650	
QLSTABRS	Rollbacks Sent	DGO0649	
QLSTBRBF	Blocks Received	DGO0660	Yes
QLSTBTBF	Blocks Sent	DGO0659	Yes
QLSTBYTR	Bytes Received	DGO0656	

Table 30. Statistics - Distributed Data Facility - per Location (continued)

Field name	Field description	Help panel name	Exception
QLSTBYTS	Bytes Sent	DGO0655	
QLSTCNVQ	Conversations Queued	DGO0643	Yes
QLSTCNVR	Conversations Received	DGO0642	
QLSTCNVS	Conversations Sent	DGO0641	
QLSTCOMR	Commits Received	DGO0648	
QLSTCOMS	Commits Sent	DGO0647	
QLSTINDT	Thread Went Indoubt	DGO0675	Yes
QLSTLOCN	Remote Location	DGO0638	
QLSTMSGR	Messages Received	DGO0654	
QLSTMSGs	Messages Sent	DGO0653	
QLSTROWR	Rows Received	DGO0652	
QLSTROWS	Rows Sent	DGO0651	
QLSTSCLR	SQL Statements Received	DGO0646	Yes
QLSTSCLS	SQL Statements Sent	DGO0645	Yes

Table 31. Statistics - Distributed Data Facility - Global

Field name	Field description	Help panel name	Exception
QDSTCNAT	Active DBATs - Currently	DGO1616	
QDSTCSTR	Cold Start Connections	DGO0762	Yes
QDSTHWAT	Active DBATs - high water mark	DGO1617	Yes
QDSTHWDT	Total DBATs - high water mark	DGO1618	Yes
QDSTQCIT	Inactive DBATs - Currently	DGO0760	
QDSTQCRT	Conversions Deallocated-Maximum Connected	DGO0759	
QDSTQDBT	DBAT Queued-Maximum Active	DGO0758	Yes
QDSTQMIT	Inactive DBATs - HWM	DGO0761	Yes
QDSTRSAT	Resynchronization Attempted	DGO0764	Yes
QDSTRSSU	Resynchronization Succeeded	DGO0765	Yes
QDSTWSTR	Warm Start Connections	DGO0763	Yes

Table 32. Statistics - EDM Pool Activity

Field name	Field description	Help panel name	Exception
QISECT	Pages Used for CT	DGO0402	
QISECTG	Requests for CT Sections	DGO0408	

Table 32. Statistics - EDM Pool Activity (continued)

Field name	Field description	Help panel name	Exception
QISECTL	CT Section Not Found In EDM Pool	DGO0409	Yes
QISEDBD	Pages Used for DBD	DGO0403	
QISEDBDG	Requests for DBD Sections	DGO0414	
QISEDBDL	DBD Section Not Found In EDM Pool	DGO0415	Yes
QISEDYNI	Inserts for Dynamic Cache	DGO1825	
QISEDYNP	Pages Used for Cache	DGO1827	
QISEDYNR	Requests for Dynamic Cache Section	DGO1826	
QISEFAIL	EDM Pool Full	DGO0407	Yes
QISEFREE	Free Pages In Free Chain	DGO0401	
QISEKT	Pages Used for PT	DGO0405	
QISEKTG	Requests for PT Sections	DGO0411	
QISEKTL	PT Sections Not Found In EDM Pool	DGO0412	Yes
QISESKCT	Pages Used for Skct	DGO0404	
QISESKPT	Pages Used for Skpt	DGO0406	
QXSTDEXP	Kept Dynamic Statement Discarded	DGO1823	
QXSTDINV	Dynamic Cache Statement Purged	DGO1824	
QXSTFND	Prepares Satisfied	DGO1819	
QXSTIPRP	Prepares Implicit	DGO1821	
QXSTNFND	Prepares Received	DGO1820	
QXSTNPRP	Prepares Avoided	DGO1822	
SERBUTP	EDM Pool Pages In Use (%)	DGO0400	
SERCTLR	CT Requests / CT Not In EDM Pool	DGO0410	Yes
SERDBLR	DBD Requests / DBD Not In EDM Pool	DGO0416	Yes
SERPTLR	PT Requests / PT Not In EDM	DGO0413	Yes

Table 33. Statistics - Global Group Buffer Pool Statistics

Field name	Field description	Help panel name	Exception
QBGBGCK	Checkpoint Interval (Minutes)	DGO1587	
QBGBGCT	Class Castout Threshold (%)	DGO1585	
QBGBGDR	Actual Directory Entries	DGO1588	
QBGBGDT	Actual Data Entries	DGO1589	
QBGBGGT	Buffer Pool Castout Threshold (%)	DGO1586	
QBGBGR1	Current Directory to Data Ratio	DGO1584	

Table 33. Statistics - Global Group Buffer Pool Statistics (continued)

Field name	Field description	Help panel name	Exception
QBGBGR2	Pending Directory to Data Ratio	DGO1590	
QBGBGSZ	Allocated Buffer Pool Size (4k)	DGO1583	
QW0254CC	Castout	DGO1575	Yes
QW0254DE	Directory Entry	DGO1576	Yes
QW0254DR	Directory Entry Reclaim	DGO1571	Yes
QW0254GN	Group Buffer Pool Name	DGO1562	
QW0254RD	Read Miss Directory Hit	DGO1565	Yes
QW0254RF	Read Miss Cache Full	DGO1567	Yes
QW0254RH	Read Hit	DGO1563	Yes
QW0254RN	Read Miss Name Assignment	DGO1566	Yes
QW0254RS	Read Miss Assignment Suppressed	DGO1564	Yes
QW0254TC	Total Changed	DGO1578	Yes
QW0254TE	Data Entry	DGO1577	Yes
QW0254TR	Data Entry Reclaim	DGO1570	Yes
QW0254WC	Clean Page Write Hit	DGO1569	Yes
QW0254WF	Write Miss Cache Full	DGO1572	Yes
QW0254WH	Changed Page Write Hit	DGO1568	Yes
QW0254XR	XI Directory Entry Reclaim	DGO1573	Yes

Table 34. Statistics - Group Buffer Pools Activity

Field name	Field description	Help panel name	Exception
QBGLAC	Clean Pages Written Asynchronously	DGO1356	Yes
QBGLAD	Asynchronous Reads - Data Returned	DGO1342	Yes
QBGLAN	Asynchronous reads - No read/write interest	DGO1344	
QBGLAW	Changed Pages Written Asynchronously	DGO1346	Yes
QBGLAX	Register page list request	DGO1656	Yes
QBGLAY	Changed pages - Read after register page list	DGO1657	Yes
QBGLAZ	Clean pages - Read after register page list	DGO1658	Yes
QBGLCC	Read Castout Class	DGO1731	
QBGLCK	GBP Checkpoints Triggered	DGO1733	
QBGLCN	Castout Engine Unavailable	DGO1350	Yes
QBGLCS	Read Castout Statistics	DGO1732	
QBGLCT	Castout Class Threshold	DGO1348	Yes

Table 34. Statistics - Group Buffer Pools Activity (continued)

Field name	Field description	Help panel name	Exception
QBGLDG	Unregister Page	DGO1729	
QBGLDN	Delete Name	DGO1726	
QBGLGN	Group Bufferpool ID	DGO1366	
QBGLGT	Group Bufferpool Castout Threshold	DGO1349	Yes
QBGLMD	Synchronous Reads Not Found - Data Returned	DGO1339	Yes
QBGLMN	Synchr. Reads Not Found - No R/W Interest	DGO1341	
QBGLMR	Sync. Read (Not Found) - No Data Returned	DGO1340	
QBGLQS	Read Storage Statistics	DGO1760	
QBGLRB	Participation in GBP Rebuild	DGO1734	
QBGLRC	Pages Castout	DGO1347	Yes
QBGLRD	Read Directory Info	DGO1727	
QBGLRF	Read Failed - No Storage	DGO1352	Yes
QBGLRG	Register Page	DGO1728	
QBGLSU	Write Engine Unavailable	DGO1351	Yes
QBGLSW	Changed Pages Written Synchronously	DGO1345	Yes
QBGLUN	Unlock Castout	DGO1730	
QBGLWC	Clean Pages Written Synchronously	DGO1355	Yes
QBGLWF	Write Failed - No Storage	DGO1353	Yes
QBGLXD	Synchr. Reads Cross Valid. - Data Returned	DGO1336	Yes
QBGLXN	Synchr. Reads Cross Valid. - No R/W Interest	DGO1338	
QBGLXR	Synchronous Read (XI) - No Data Returned	DGO1337	

Table 35. Statistics - Locking Activity

Field name	Field description	Help panel name	Exception
QTXACHG	Change Requests	DGO0480	
QTXACLNO	Claim Requests	DGO0486	
QTXACLUN	Unsuccessful Claim Requests	DGO0487	Yes
QTXADEA	Deadlocks	DGO0476	Yes
QTXADRNO	Drain Requests	DGO0484	
QTXADRUN	Unsuccessful Drain Requests	DGO0485	Yes
QTXAIRLM	Other Requests	DGO0481	
QTXALES	Lock Escalation (shared)	DGO0482	Yes
QTXALEX	Lock Escalation (exclusive)	DGO0483	Yes

Table 35. Statistics - Locking Activity (continued)

Field name	Field description	Help panel name	Exception
QTXALOCK	Lock Requests	DGO0477	
QTXAQRY	Query Requests	DGO0479	
QTXASLAT	Suspensions (latch only)	DGO0473	
QTXASLOC	Suspensions (lock only)	DGO0472	Yes
QTXASOTH	Suspensions (other)	DGO0474	
QTXATIM	Timeouts	DGO0475	Yes
QTXAUNLK	Unlock Requests	DGO0478	
SLCLKET	Lock Escalations	DGO0768	Yes
SLRLCRLS	Lock and Change Requests per Lock Suspension	DGO0808	
SLRSUSP	Suspensions (all)	DGO0471	Yes

Table 36. Statistics - Log Activity

Field name	Field description	Help panel name	Exception
QJSTALR	Archive Log Read Allocations	DGO0519	
QJSTALW	Archive Log - Write Allocations	DGO0520	
QJSTBFFL	Control Intervals Created	DGO0518	
QJSTBFWR	Write Output Log Buffers	DGO0515	
QJSTBSDS	Total BSDS Access Request	DGO0516	
QJSTCIOF	Archive Log - Control Intervals Offloaded	DGO0807	
QJSTLAMA	Look Ahead Mounts Attempted	DGO0512	
QJSTLAMS	Look Ahead Mount Successful	DGO0513	
QJSTRACT	Reads Satisfied - Active Log	DGO0505	Yes
QJSTRARH	Reads Satisfied - Archive Log	DGO0507	Yes
QJSTRBUF	Reads Satisfied - Output Buffer	DGO0503	Yes
QJSTTVC	Reads Delayed - Tape Volume Contention	DGO0510	Yes
QJSTWRNW	Write-no-wait	DGO0514	
QJSTWTB	Unavailable Output Log Buffers	DGO0517	Yes
QJSTWUR	Reads Delayed - Unavailable Resource	DGO0511	Yes
SARLRACT	Reads Satisfied - Active Log(%)	DGO0506	
SARLRARC	Reads Satisfied - Archive Log(%)	DGO0508	
SARLRBUF	Reads Satisfied - Output Buffer(%)	DGO0504	
SARWBAC	Out Log Buf Writes / Act. Log Cntl I'val	DGO0806	Yes

Table 37. Statistics - Miscellaneous

Field name	Field description	Help panel name	Exception
QISTCOLS	Columns Bypassed	DGO0770	
QWSDLR	Log RBA	DGO0636	
QWSDRINV	Reason Invoke	DGO0637	

Table 38. Statistics - Open/Close Activity

Field name	Field description	Help panel name	Exception
QTDSDRN	Data Sets Closed Threshold Reached	DGO0426	Yes
QTDSOPN	Open Data Sets - Current	DGO0418	Yes
QTMAXDS	Open Data Sets - HWM	DGO0417	Yes
QTMXPB	Open Data Sets - Not In Use, Not Closed (HWM)	DGO0422	Yes
QTPCCT	Data Sets Converted R/W To R/O	DGO0755	Yes
QTREOPN	Successful Logical Reopens	DGO0429	
QTSLWDD	Open DSs - Not In Use, Not Closed (current)	DGO0420	Yes
SDINUSEC	Open Data Sets In Use	DGO0757	Yes

Table 39. Statistics - Plan/Package Processing

Field name	Field description	Help panel name	Exception
QTABIND	Autobind Plan Successful	DGO0442	Yes
QTABINDA	Autobind Plan Attempts	DGO0441	Yes
QTALLOC	Plan Allocation Successful	DGO0431	
QTALLOCA	Plan Allocation Attempts	DGO0430	
QTAUTOBA	Auto Bind Package Attempts	DGO0444	Yes
QTBINDA	Bind Plan Add Subcommands	DGO0435	
QTBINDPA	Bind Package Add Subcommand	DGO0439	
QTBINDPR	Bind Package Replace Subcommand	DGO0440	
QTBINDR	Bind Plan Replace Subcommands	DGO0436	
QTFREE	Free Plan Subcommands	DGO0452	
QTFREEA	Free Plan Attempts	DGO0453	
QTFREEAP	Free Package Attempts	DGO0456	
QTFREEP	Free Package Subcommands	DGO0455	
QTINVRID	Autobind Plan Invalid Resource ID	DGO0443	Yes
QTPKABND	Auto Bind Packages Successful	DGO0445	Yes
QTPKALL	Package Allocation Successful	DGO0433	

Table 39. Statistics - Plan/Package Processing (continued)

Field name	Field description	Help panel name	Exception
QTPKALLA	Package Allocation Attempts	DGO0432	
QTPKGBD	Packages Bound	DGO0438	
QTPKGFRD	Free Package Successful	DGO0457	
QTPKGRBD	Rebind Package Successful	DGO0451	
QTPLNBD	Plans Bound	DGO0434	
QTPLNFRD	Free Plan Successful	DGO0454	
QTPLNRBD	Rebind Plan Successful	DGO0448	
QTRBINDA	Rebind Plan Attempts	DGO0447	
QTRBINDP	Rebind Package Subcommands	DGO0449	
QTRBNDPA	Rebind Package Attempts	DGO0450	
QTREBIND	Rebind Plan Subcommands	DGO0446	
QTTESTB	Test Binds No Plan-ID	DGO0437	

Table 40. Statistics - Query Parallelism

Field name	Field description	Help panel name	Exception
QXCOORNO	One Db2 - COORDINATOR Parm = NO	DGO1672	
QXDEGBUF	Fall To Sequential Mode (no buffer)	DGO0327	Yes
QXDEGCUR	Fall To Sequential Mode Cursor	DGO0748	Yes
QXDEGESA	Fall To Sequential Mode No ESA	DGO0747	Yes
QXISORR	One Db2 - Isolation Level	DGO1673	
QXMAXDEG	Maximum Degree of Parallelism	DGO0326	
QXNORGRP	Planned Parallel Degree	DGO0329	
QXREDGRP	Reduced Parallel Degree	DGO0328	Yes
QXTOTGRP	Parallel Groups Executed	DGO0749	
SDTOTPFL	Parallel Fall To Sequential	DGO0746	Yes
SXXCRAT	Member Skipped (%)	DGO1798	

Table 41. Statistics - RID List Processing

Field name	Field description	Help panel name	Exception
QISTRCUR	RID Blocks Allocated - Current	DGO0466	
QISTRHIG	RID Blocks Allocated - Maximum	DGO0465	Yes
QISTRLLM	Terminated - RDS Limit Exceeded	DGO0468	Yes
QISTRMAX	Terminated - Process Limit Exceeded	DGO0470	Yes

Table 41. Statistics - RID List Processing (continued)

Field name	Field description	Help panel name	Exception
QISTRPLM	Terminated - DM Limit Exceeded	DGO0469	Yes
QISTRSTG	Terminated - No Storage	DGO0467	Yes
SRTTERM	Number of Times RID List Processing Not Used	DGO0767	Yes

Table 42. Statistics - SQL Activity (DCL)

Field name	Field description	Help panel name	Exception
QXALOCC	Allocate Cursor	DGO1740	
QXALOCL	Associate Locators	DGO1739	
QXCON1	Connect Type 1	DGO0296	
QXCON2	Connect Type 2	DGO0297	
QXGRANT	Grant	DGO0292	
QXLOCK	Lock Table	DGO0291	
QXREL	Release	DGO0298	
QXREVOK	Revoke	DGO0293	
QXSETCDG	Set Current Degree	DGO0742	
QXSETCON	Set Connection	DGO0299	
QXSETCRL	Set Current Rules	DGO1357	
QXSETHV	Set Host Variable	DGO0295	
QXSETSQL	Set Current SQLID	DGO0294	
SSCDCL	Total DCL	DGO0300	Yes

Table 43. Statistics - SQL Activity (DDL)

Field name	Field description	Help panel name	Exception
QXALDAB	Alter Database	DGO0312	
QXALTIX	Alter Index	DGO0310	
QXALTST	Alter Stogroup	DGO0313	
QXALTTA	Alter Table	DGO0309	
QXALTTS	Alter Tablespace	DGO0311	
QXCMTON	Comment On	DGO0323	
QXCRALS	Create Alias	DGO0308	
QXCRDAB	Create Database	DGO0306	
QXCRGTT	Temp. Table	DGO1671	
QXCRINX	Create Index	DGO0302	

Table 43. Statistics - SQL Activity (DDL) (continued)

Field name	Field description	Help panel name	Exception
QXCRSTG	Create Stogroup	DGO0307	
QXCRSYN	Create Synonym	DGO0304	
QXCRTAB	Create Table	DGO0301	
QXCTABS	Create Tablespace	DGO0305	
QXDEFVU	Create View	DGO0303	
QXDRPAL	Drop Alias	DGO0321	
QXDRPDB	Drop Database	DGO0319	
QXDRPIX	Drop Index	DGO0315	
QXDRPPKG	Drop Package	DGO0322	
QXDRPST	Drop Stogroup	DGO0320	
QXDRPSY	Drop Synonym	DGO0317	
QXDRPTA	Drop Table	DGO0314	
QXDRPTS	Drop Tablespace	DGO0318	
QXDRPVU	Drop View	DGO0316	
QXLABON	Label On	DGO0324	
QXRNTAB	Rename Table	DGO1828	
SDTOTALT	Alters	DGO0743	
SDTOTCRT	Creates	DGO0745	
SDTOTDRP	Drops	DGO0744	
SSCDDL	Total DDL	DGO0325	Yes

Table 44. Statistics - SQL Activity (DML)

Field name	Field description	Help panel name	Exception
QXCLOSE	Close Cursor	DGO0288	
QXDELETE	Delete	DGO0283	
QXDESC	Describe	DGO0285	
QXDSCRTB	Describe Table	DGO0286	
QXFETCH	Fetch	DGO0289	
QXINSRT	Insert	DGO0281	
QXOPEN	Open Cursor	DGO0287	
QXPREP	Prepare	DGO0284	
QXSELECT	Select	DGO0280	
QXUPDTE	Update	DGO0282	

Table 44. Statistics - SQL Activity (DML) (continued)

Field name	Field description	Help panel name	Exception
SSCDML	Total DML	DGO0290	Yes

Table 45. Statistics - SQL Nested Activity

Field name	Field description	Help panel name	Exception
QXCALL	Call Statements Executed	DGO1358	
QXCALLAB	Procedure Abends	DGO1363	Yes
QXCALLRJ	Call Statement Rejected	DGO1365	Yes
QXCALLTO	CALL Statement Timeouts	DGO1364	Yes

Table 46. Statistics - Subsystem Services

Field name	Field description	Help panel name	Exception
QWSDCKPT	System Event Checkpoint	DGO0535	Yes
Q3STABRT	Rollback	DGO0525	Yes
Q3STCOMM	Commits Phase 2	DGO0527	
Q3STCTHD	Create Thread	DGO0522	Yes
Q3STCTHW	Queued At Create Thread	DGO0532	Yes
Q3STIDEN	Identify	DGO0521	
Q3STINDT	Units of Recovery Gone Indoubt	DGO0529	Yes
Q3STMEOM	Subsystem Allied Memory End of Memory	DGO0534	Yes
Q3STMEOT	Subsystem Allied Memory End of Task	DGO0533	Yes
Q3STPREP	Commits Phase 1	DGO0526	
Q3STRDON	Commits Read Only	DGO0528	
Q3STRIUR	Units of Recovery Indoubt Resolved	DGO0530	
Q3STSIGN	Signon	DGO0523	Yes
Q3STSYNC	Synchs (single phase commit)	DGO0531	
Q3STTERM	Terminate	DGO0524	

Table 47. Statistics - Times

Field name	Field description	Help panel name	Exception
SDDFSRBT	DDF Address Space SRB Time	DGO0498	
SDDFTCBT	DDF Address Space TCB Time	DGO0497	
SDDFTOTT	DDF Address Space Total Time	DGO0499	Yes
SDISRBT	IRLM SRB Time	DGO0495	

Table 47. Statistics - Times (continued)

Field name	Field description	Help panel name	Exception
SDITCBT	IRLM TCB Time	DGO0494	
SDITOTT	IRLM Total Time	DGO0496	Yes
SDSRBT	Database Services SRB Time	DGO0492	
SDTCBT	Database Services TCB Time	DGO0491	
SDTLRBT	Total	DGO0501	
SDTLTCBT	Total	DGO0500	
SDTLTOTT	Total	DGO0502	
SDTOTT	Database Services Total Time	DGO0493	Yes
SSSRBT	System Services SRB Time	DGO0489	
SSTCBT	System Services TCB Time	DGO0488	
SSTOTT	System Services Total Time	DGO0490	Yes

Table 48. System Parameters - Application Programming Defaults

Field name	Field description	Help panel name
QWPBAGID	ASCII GBCS CCSID	DGO1741
QWPBAMID	ASCII MBCS CCSID	DGO1742
QWPBAR	Default Decimal Arithmetic	DGO1748
QWPBASID	ASCII SBCS CCSID	DGO1743
QWPBCHAR	Default Character Set	DGO1763
QWPBDATE	Date Format	DGO1755
QWPBDE	Decimal Point Option	DGO1747
QWPBDL	Default Delimiter	DGO1749
QWPBDLEN	Local Date Length	DGO1757
QWPBDS	Distributed SQL String Delimiter	DGO1754
QWPBENS	Default Encoding Scheme	DGO1750
QWPBGID	EBCDIC GBCS CCSID	DGO1744
QWPBGRA	Default Mixed Graphic	DGO1752
QWPBLANG	Default Host Language	DGO1751
QWPBMID	EBCDIC MBCS CCSID	DGO1745
QWPBSDL	Default SQL Delimiter	DGO1753
QWPBSID	EBCDIC SBCS CCSID	DGO1746
QWPBSQL	SQL Language Support Level	DGO1759
QWPBTIME	Time Format	DGO1756
QWPBTLEN	Local Time Length	DGO1758

Table 48. System Parameters - Application Programming Defaults (continued)

Field name	Field description	Help panel name
QWP4CDEG	Current Degree (CDSSRDEF)	DGO1659
QWP4CDYN	Cache Dynamic SQL Statements	DGO1809
QWP4RCHL	Release Cursor Hold Locks	DGO1814

Table 49. System Parameters - Archive Log Installation Parameters

Field name	Field description	Help panel name
QWP2ADL	Number of Copies	DGO1416
QWP2ARCL	Maximum Data Sets Recorded In BSDS	DGO1242
QWP2MRTU	Maximum Read Tape Units	DGO1248
QWP3BKSZ	Archive Log Block Size	DGO1251
QWP3COMP	Compact Data	DGO1252
QWP3CTLG	Catalog Archive Data Sets	DGO1253
QWP3CYL	Space Allocation Method	DGO1420
QWP3DTIM	Timestamp Archive Log Data Sets	DGO1254
QWP3MQP	Quiesce Period (seconds)	DGO1255
QWP3MSV1	Archive Copy 1 Mass Storage Group Name	DGO1256
QWP3MSV2	Archive Copy 2 Mass Storage Group Name	DGO1257
QWP3RETN	Days To Retain Archive Log Data Sets	DGO1258
QWP3RE1N	Copy 1 Prefix	DGO1259
QWP3RE2N	Copy 2 Prefix	DGO1260
QWP3RISP	Primary Space	DGO1261
QWP3SECS	Secondary Space	DGO1263
QWP3UNT1	Copy 1 Archive Log Device Type	DGO1264
QWP3UNT2	Copy 2 Archive Log Device Type	DGO1419
QWP3WTOR	Issue WTOR Before Mount for Archive Volume	DGO1265
ZWP2TIME	Tape Unit Deallocation Period	DGO1424

Table 50. System Parameters - Buffer Pool Information Page

Field name	Field description	Help panel name
QDBPCAST	Castout Attribute	DGO1210
QDBPDWQT	Deferred Write Threshold	DGO1211
QDBPNM	Buffer Pool Name	DGO1214
QDBPPSQT	Parallel Sequential Threshold	DGO1215
QDBPVDQT	Vertical Deferred Write Threshold	DGO1216
QDBPVPSH	Virtual Sequential Threshold	DGO1217

Table 50. System Parameters - Buffer Pool Information Page (continued)

Field name	Field description	Help panel name
QDBPVPSZ	Virtual Pool Size	DGO1218
QDBPXSQT	Assisting Parallel Sequential Threshold	DGO1660

Table 51. System Parameters - Data Definition Control Support

Field name	Field description	Help panel name
QWP4ESC	Escape Character	DGO1273
QWP4REGA	Application Registration Table	DGO1286
QWP4REGC	Register Table Owner	DGO1287
QWP4REGD	Control All Applications	DGO1288
QWP4REGI	Install DD Control	DGO1289
QWP4REGN	DDL Registration Database Name	DGO1290
QWP4REGO	Object Registration Table	DGO1291
QWP4REGQ	Require Full Names	DGO1292
QWP4REGU	Unregistered DDL Default	DGO1293

Table 52. System Parameters - Data Installation Parameters

Field name	Field description	Help panel name
QWP6CATN	Icf Catalog Qualifier	DGO1303

Table 53. System Parameters - Data-Sharing Parameters

Field name	Field description	Help panel name
QWPAASST	Parallelism Assistant	DGO1780
QWPACOR	Query coordinator	DGO1675
QWPAGRPN	Group name	DGO1455
QWPAIOPT	Data sharing enabled	DGO1548
QWPAMAXM	Maximum number of members	DGO1549
QWPAMBRN	Member name	DGO1547
QWPASUCV	SU conversion factor	DGO1676

Table 54. System Parameters - Distributed Data Facility Parameters

Field name	Field description	Help panel name
QWP1SCER	Extended Security	DGO1674
QWP4HOP	Hop Site Authorization	DGO1274
QWP9CMST	DBAT Status	DGO1304
QWP9RLFN	Resource Limit Spec. Table Error Action (DDF)	DGO1305
QWP9RYC	Resynchronization Interval (minutes)	DGO1306

Table 54. System Parameters - Distributed Data Facility Parameters (continued)

Field name	Field description	Help panel name
QWP9STRT	Db2 Startup Option	DGO1307
QWP9TTO	Idle Thread Timeout Interval	DGO1435

Table 55. System Parameters - Group Buffer Pools Parameters Page

Field name	Field description	Help panel name
QBGBGAS	AUTOREC (automatic recovery)	DGO1725
QBGBGDR	Actual Directory Entry	DGO1559
QBGBGDT	Actual Data Entry	DGO1560
QBGBGR2	Pending Directory to Data Ratio	DGO1561
QBGBGSZ	Allocated Buffer Pool Size (4K)	DGO1558

Table 56. System Parameters - IRLM Installation Parameters

Field name	Field description	Help panel name
QWP4IAUT	Automatic Start	DGO1405
QWP4IPRC	Start Procedure Name	DGO1276
QWP4ISID	Subsystem Name	DGO1277
QWP4ISWT	Time Db2 Will Wait for Start (seconds)	DGO1278
QWP4TOUT	Resource Timeout (seconds)	DGO1299
QWP4UTO	Utility Timeout Factor	DGO1300

Table 57. System Parameters - Lock Escalation Parameters

Field name	Field description	Help panel name
QWP4LKTS	Maximum Locks per Table Space	DGO1279
QWP4LKUS	Maximum Locks per User	DGO1280
QWP4WAIT	Wait For Retained Locks	DGO1738

Table 58. System Parameters - Log Installation Parameters

Field name	Field description	Help panel name
QWP2DUAL	Number of Copies	DGO1431
QWP2IBPS	Input Buffer Size (KB)	DGO1246
QWP2OBPS	Output Buffer Size (KB)	DGO1249
QWP2WRTH	Write Threshold On Filled Buffers	DGO1250

Table 59. System Parameters - Operator Functions Installation Parameters

Field name	Field description	Help panel name
QWP1RLF	Resource Limit Facility Automatic Start	DGO1228
QWP1RLFN	Resource Limit Spec. Table Error Action	DGO1230

Table 59. System Parameters - Operator Functions Installation Parameters (continued)

Field name	Field description	Help panel name
QWP1RLFT	Resource Limit Specification Table Suffix	DGO1231
QWP1SMRC	WTO Route Codes	DGO1236
QWP4ABN	Allow Autobind Operations	DGO1266
QWP4ABX	Allow Explain At Autobind	DGO1267
QWP4ENF	DPROP Support	DGO1404
QWP4SIT	Site Type	DGO1296
QWP9TCPA	TCP/IP Already Verified	DGO1761

Table 60. System Parameters - Other System Parameters

Field name	Field description	Help panel name
MZDBSTRT	Databases and Table Spaces	DGO1208
QWP1DFRQ	Checkpoints Level ID Updates	DGO1434
QWP2DBSD	Dual BSDS Mode	DGO1243
QWP4DSMX	Maximum Open Data Sets (DSMAX)	DGO1271
QWP4DSST	Static describe (DESCSTAT)	DGO1701
QWP4ISWI	IRLM Initial Inquiry by Db2	DGO1433
QWP4MDDN	Asynchronous Drain Stop (%DSMAX)	DGO1281
QWP4TDDN	Asynchronous Drain Start (%DSMAX)	DGO1298
QWP4WBMP	IMS/BMP time-out factor (BMPTOUT)	DGO1669
QWP4WDLI	IMS/DLI time-out factor (DLITOUT)	DGO1670
XWP4CDEG	Current Degree (CDEGREE)	DGO1859

Table 61. System Parameters - Protection Installation Parameters

Field name	Field description	Help panel name
QWP1RLFA	Resource Limit Table Creator Authid	DGO1229
QWP3RTCT	RACF® Protect Archive Log	DGO1262
QWP4ADM2	System Administrator 2 Authid	DGO1268
QWP4AUCA	Plan Authorization Cache Size	DGO1428
QWP4AUTH	Db2 Authorization Enabled	DGO1269
QWP4BNVA	Bind New Version	DGO1430
QWP4DFID	Default (unknown) User Authid	DGO1270
QWP4OPR1	System Operator 1 Authid	DGO1283
QWP4OPR2	System Operator 2 Authid	DGO1284
QWP4PAC	Package Authorization Cache Size	DGO1779
QWP4SADM	System Administrator 1 Authid	DGO1294

Table 62. System Parameters - Storage Sizes Installation Parameters

Field name	Field description	Help panel name
QWP1CDB	Maximum Remote	DGO1220
QWP1CT	Maximum Concurrent Threads	DGO1221
QWP1IDB	Maximum Batch	DGO1223
QWP1IDF	Maximum TSO	DGO1224
QWP1RMT	Maximum Remote Active	DGO1232
QWP4EDPL	Maximum Size of EDM Pool	DGO1272
QWP4IXTP	Default Index Type	DGO1546
QWP4MXKD	Maximum Kept Dynamic Statements	DGO1810
QWP4PST	Utility Cache Option	DGO1766
QWP4RMAX	Maximum Size of RID Pool	DGO1396
QWP4SCAC	3990 Cache	DGO1295
QWP4SPOL	Maximum Size of Sort Pool	DGO1297

Table 63. System Parameters - Stored Procedures Parameters

Field name	Field description	Help panel name
QWP1SPAB	Abends Allowed	DGO1437
QWP1SPPN	MVS Procedure Name	DGO1436
QWP1SPTO	Timeout Value	DGO1438

Table 64. System Parameters - Tracing, Checkpoint and Pseudo-Close Parameters

Field name	Field description	Help panel name
QWP1AUDT	Start Audit Trace	DGO1219
QWP1FREQ	Pseudo-Close Frequency	DGO1222
QWP1LOGL	Checkpoint Frequency	DGO1225
QWP1MON	Start Monitor Trace	DGO1226
QWP1MONS	Monitor Buffer Size (bytes)	DGO1227
QWP1SMFA	Start SMF Accounting	DGO1234
QWP1SMFS	Start SMF Statistics Trace	DGO1235
QWP1STIM	Statistics Interval (minutes)	DGO1237
QWP1TMR	Pseudo-Close Timer	DGO1238
QWP1TRST	Start Global Trace	DGO1239
QWP1TRSZ	Trace Table Size (4 KB multiple)	DGO1240
QWP1URCK	UR Check Frequency	DGO1712

Layout of the Exception Log File output record

The table in this section outlines the format of the Exception Log File data set output record. Use these terms to interpret the table.

Offset

Length from the beginning of the record to the start of the field.

Length

Length of the field, in bytes.

Db2 Data Type

The format of the value in the field:

- SMALLINT
- INTEGER
- CHAR
- TIMESTAMP
- DOUBLE PRECISION

Table 65. Layout of the Exception Log File output record

Offset (decimal)	Length (bytes)	Db2 Data Type	Description
N/A	2	SMALLINT	Length of record (LL)
N/A	2	SMALLINT	Binary zeros
0	1	CHAR	Log record type: <ul style="list-style-type: none"> • F = Field-level exception record • M = Exception message (Online Monitor only)
1	1	CHAR	Processing origin ID: <ul style="list-style-type: none"> • B = Record written by batch exception processor • S = Record written by online display exception processor • A = Record written by online periodic exception processor
2	4	CHAR	Per: <ul style="list-style-type: none"> • SYST = System • PROG = Program • PLAN = Plan name
6	16	CHAR	Local location
22	2	CHAR	Reserved
24	8	CHAR	Primary authorization ID
32	8	CHAR	Original authorization ID
40	8	CHAR	Plan name
48	8	CHAR	Connection ID
56	8	CHAR	Connection type
64	12	CHAR	Untranslated correlation ID

Table 65. Layout of the Exception Log File output record (continued)

Offset (decimal)	Length (bytes)	Db2 Data Type	Description
76	8	CHAR	Correlation name
84	8	CHAR	Correlation number
92	8	CHAR	Network ID
100	8	CHAR	VTAM LU name
108	12	CHAR	Instance number
120	2	SMALLINT	LUW sequence number
122	18	CHAR	Main package (MAINPACK)
140	16	CHAR	Requesting location
156	2	CHAR	Reserved
158	4	CHAR	Db2 subsystem ID
162	6	CHAR	OMEGAMON XE for Db2 PE VnRnMn
168	6	CHAR	Db2 VnRnMn
174	1	SMALLINT	Db2 release code
175	8	CHAR	Store clock timestamp
183	26	TIMESTAMP	Db2 timestamp
209	8	CHAR	Field name
217	1	CHAR	Field type: <ul style="list-style-type: none"> • Blank = Normal field • B = Buffer pool field • D = DDF field • G = Group buffer pool field • C = Global group buffer pool statistics field • P = Package
218	54	CHAR	Field name qualifier used in the Exception Threshold data set
272	2	CHAR	Reserved
274	54	CHAR	Actual field name qualifier: <ul style="list-style-type: none"> • Buffer pool ID for buffer pool records • Remote location for DDF records • Package location, connection ID, and program name for package records • Blank for all other records
328	2	CHAR	Reserved
330	1	CHAR	Reserved
331	1	CHAR	Field description (without qualifier)

Table 65. Layout of the Exception Log File output record (continued)

Offset (decimal)	Length (bytes)	Db2 Data Type	Description
371	40	CHAR	Compare basis: <ul style="list-style-type: none"> • V = Total value • M = By minute • S = By second • C = By commit • T = By thread
372	1	CHAR	Operator (> or <)
373	12	CHAR	Exception value (character)
385	12	CHAR	Threshold value (character)
397	1	CHAR	Exception level: <ul style="list-style-type: none"> • P = Problem • W = Warning
398	8	DOUBLE PRECISION	Exception value (floating point)
406	8	DOUBLE PRECISION	Threshold value (floating point)
414	8	CHAR	Group name
422	8	CHAR	Member name

Note: The exception and threshold values in floating-point form (offsets 398 and 406 respectively) can contain time or counts fields. For time fields, the value is stored in terms of microseconds. For example, if you entered 0.3 seconds for the threshold value, it is stored as 300 000 microseconds in the Exception Log File data set. For counts fields, the value is stored as the actual value.

Product legal notices

This information was developed for products and services offered in the U.S.A.

This material may be available from IBM in other languages. However, you may be required to own a copy of the product or product version in that language in order to access it.

IBM may not offer the products, services, or features discussed in this document in other countries. Consult your local IBM representative for information on the products and services currently available in your area. Any reference to an IBM product, program, or service is not intended to state or imply that only that IBM product, program, or service may be used. Any functionally equivalent product, program, or service that does not infringe any IBM intellectual property right may be used instead. However, it is the user's responsibility to evaluate and verify the operation of any non-IBM product, program, or service.

IBM may have patents or pending patent applications covering subject matter described in this document. The furnishing of this document does not give you any license to these patents. You can send license inquiries, in writing, to:

IBM Director of Licensing IBM Corporation North Castle Drive Armonk, NY 10504-1785 U.S.A.

For license inquiries regarding double-byte (DBCS) information, contact the IBM Intellectual Property Department in your country or send inquiries, in writing, to:

Intellectual Property Licensing Legal and Intellectual Property Law IBM Japan Ltd. 19-21, Nihonbashi-Hakozakicho, Chuo-ku Tokyo 103-8510, Japan

The following paragraph does not apply to the United Kingdom or any other country where such provisions are inconsistent with local law: INTERNATIONAL BUSINESS MACHINES CORPORATION PROVIDES THIS PUBLICATION "AS IS" WITHOUT WARRANTY OF ANY KIND, EITHER EXPRESS OR IMPLIED, INCLUDING, BUT NOT LIMITED TO, THE IMPLIED WARRANTIES OF NON-INFRINGEMENT, MERCHANTABILITY OR FITNESS FOR A PARTICULAR PURPOSE. Some states do not allow disclaimer of express or implied warranties in certain transactions, therefore, this statement may not apply to you.

This information could include technical inaccuracies or typographical errors. Changes are periodically made to the information herein; these changes will be incorporated in new editions of the publication. IBM may make improvements and/or changes in the product(s) and/or the program(s) described in this publication at any time without notice.

Any references in this information to non-IBM Web sites are provided for convenience only and do not in any manner serve as an endorsement of those Web sites. The materials at those Web sites are not part of the materials for this IBM product and use of those Web sites is at your own risk.

IBM may use or distribute any of the information you supply in any way it believes appropriate without incurring any obligation to you.

Licensees of this program who wish to have information about it for the purpose of enabling: (i) the exchange of information between independently created programs and other programs (including this one) and (ii) the mutual use of the information which has been exchanged, should contact:

IBM Director of Licensing IBM Corporation North Castle Drive Armonk, NY 10504-1785 U.S.A.

Such information may be available, subject to appropriate terms and conditions, including in some cases, payment of a fee.

The licensed program described in this information and all licensed material available for it are provided by IBM under terms of the IBM Customer Agreement, IBM International Program License Agreement, or any equivalent agreement between us.

Any performance data contained herein was determined in a controlled environment. Therefore, the results obtained in other operating environments may vary significantly. Some measurements may have been made on development-level systems and there is no guarantee that these measurements will be the same on generally available systems. Furthermore, some measurements may have been estimated

through extrapolation. Actual results may vary. Users of this document should verify the applicable data for their specific environment.

Information concerning non-IBM products was obtained from the suppliers of those products, their published announcements or other publicly available sources. IBM has not tested those products and cannot confirm the accuracy of performance, compatibility or any other claims related to non-IBM products. Questions on the capabilities of non-IBM products should be addressed to the suppliers of those products.

All statements regarding IBM's future direction or intent are subject to change or withdrawal without notice, and represent goals and objectives only.

This information is for planning purposes only. The information herein is subject to change before the products described become available.

This information contains examples of data and reports used in daily business operations. To illustrate them as completely as possible, the examples include the names of individuals, companies, brands, and products. All of these names are fictitious and any similarity to the names and addresses used by an actual business enterprise is entirely coincidental.

COPYRIGHT LICENSE:

This information contains sample application programs in source language, which illustrate programming techniques on various operating platforms. You may copy, modify, and distribute these sample programs in any form without payment to IBM, for the purposes of developing, using, marketing or distributing application programs conforming to the application programming interface for the operating platform for which the sample programs are written. These examples have not been thoroughly tested under all conditions. IBM, therefore, cannot guarantee or imply reliability, serviceability, or function of these programs. The sample programs are provided "AS IS", without warranty of any kind. IBM shall not be liable for any damages arising out of your use of the sample programs.

Each copy or any portion of these sample programs or any derivative work, must include a copyright notice as follows:

© (your company name) (year). Portions of this code are derived from IBM Corp. Sample Programs. © Copyright IBM Corp. _enter the year or years_. All rights reserved.

If you are viewing this information softcopy, the photographs and color illustrations may not appear.

Programming interface information

This publication documents intended Programming Interfaces that allow the customer to write programs to obtain the services of OMEGAMON for Db2 Performance Expert.

This publication documents information that is NOT intended to be used as Programming Interfaces of OMEGAMON for Db2 Performance Expert.

This publication primarily documents intended Programming Interfaces that allow the customer to write programs to obtain the services of OMEGAMON for Db2 Performance Expert.

This publication also documents information that is NOT intended to be used as Programming Interfaces of OMEGAMON for Db2 Performance Expert. This information is identified where it occurs by an introductory statement to a topic or section.

This publication primarily documents information that is NOT intended to be used as Programming Interfaces of OMEGAMON for Db2 Performance Expert.

This publication also documents intended Programming Interfaces that allow the customer to write programs to obtain the services of OMEGAMON for Db2 Performance Expert. This information is identified where it occurs by an introductory statement to a topic or section.

Trademarks

IBM, the IBM logo, and [ibm.com](http://www.ibm.com)® are trademarks or registered trademarks of International Business Machines Corp., registered in many jurisdictions worldwide. Other product and service names might be trademarks of IBM or other companies. A current list of IBM trademarks is available on the web at "Copyright and trademark information" at <http://www.ibm.com/legal/copytrade.html>.

Adobe™, the Adobe logo, PostScript™, and the PostScript logo are either registered trademarks or trademarks of Adobe Systems Incorporated in the United States, and/or other countries.

Intel™, Intel logo, Intel Inside™, Intel Inside logo, Intel Centrino™, Intel Centrino logo, Celeron™, Xeon, Intel SpeedStep™, Itanium™, and Pentium™ are trademarks or registered trademarks of Intel Corporation or its subsidiaries in the United States and other countries.

Java™ and all Java-based trademarks and logos are trademarks or registered trademarks of Oracle and/or its affiliates.

Linux® is a registered trademark of Linus Torvalds in the United States, other countries, or both.

Microsoft™, Windows, Windows NT™, and the Windows logo are trademarks of Microsoft Corporation in the United States, other countries, or both.

UNIX® is a registered trademark of The Open Group in the United States and other countries.

Other company, product, and service names may be trademarks or service marks of others.

Terms and conditions for product documentation

Permissions for the use of these publications are granted subject to the following terms and conditions:

Applicability: These terms and conditions are in addition to any terms of use for the IBM website.

Personal use: You may reproduce these publications for your personal, noncommercial use provided that all proprietary notices are preserved. You may not distribute, display or make derivative work of these publications, or any portion thereof, without the express consent of IBM.

Commercial use: You may reproduce, distribute and display these publications solely within your enterprise provided that all proprietary notices are preserved. You may not make derivative works of these publications, or reproduce, distribute or display these publications or any portion thereof outside your enterprise, without the express consent of IBM.

Rights: Except as expressly granted in this permission, no other permissions, licenses or rights are granted, either express or implied, to the publications or any information, data, software or other intellectual property contained therein.

IBM reserves the right to withdraw the permissions granted herein whenever, in its discretion, the use of the publications is detrimental to its interest or, as determined by IBM, the above instructions are not being properly followed.

You may not download, export or re-export this information except in full compliance with all applicable laws and regulations, including all United States export laws and regulations.

IBM MAKES NO GUARANTEE ABOUT THE CONTENT OF THESE PUBLICATIONS. THE PUBLICATIONS ARE PROVIDED "AS-IS" AND WITHOUT WARRANTY OF ANY KIND, EITHER EXPRESSED OR IMPLIED, INCLUDING BUT NOT LIMITED TO IMPLIED WARRANTIES OF MERCHANTABILITY, NON-INFRINGEMENT, AND FITNESS FOR A PARTICULAR PURPOSE.

Privacy policy considerations

IBM Software products, including software as a service solutions, ("Software Offerings") may use cookies or other technologies to collect product usage information, to help improve the end user experience, to tailor interactions with the end user or for other purposes. In many cases no personally identifiable information is collected by the Software Offerings. Some of our Software Offerings can help enable you to collect personally identifiable information. If this Software Offering uses cookies to collect personally identifiable information, specific information about this offering's use of cookies is set forth below.

This Software Offering does not use cookies or other technologies to collect personally identifiable information.

If the configurations deployed for this Software Offering provide you as customer the ability to collect personally identifiable information from end users via cookies and other technologies, you should seek your own legal advice about any laws applicable to such data collection, including any requirements for notice and consent.

For more information about the use of various technologies, including cookies, for these purposes, see IBM's Privacy Policy at <http://www.ibm.com/privacy> and the section titled "Cookies, Web Beacons, and Other Technologies" in IBM's Online Privacy Statement at <http://www.ibm.com/privacy/details>. Also, see the "IBM Software Products and Software-as-a-Service Privacy Statement" at <http://www.ibm.com/software/info/product-privacy>.

Index

A

- accessibility
 - overview [4](#)
- application development [160](#)
- Asynchronous Task Termination panel [15](#)
- authorization
 - changing SQL authorization [13](#)
 - Explain function [130](#)
 - requirements [5](#)
 - viewing attempts and successes [104](#)
- authorization failure
 - listing [41](#)
- Authorization Failure Summary window [41](#)
- AUTO command
 - statistics [127](#)
 - thread activity [80](#)
- Auto Display window [12](#)
- AUTOEXCPTHNAME
 - OMEGAMON Collector startup parameter [35](#)

B

- bind activity
 - ACQUIRE and RELEASE to reduce thread creation costs [109](#)
 - viewing statistics on plans [103](#)
- Bind Processing window [103](#)
- Buffer Manager Activity window [67](#)
- Buffer Manager window [96](#)
- buffer pool
 - listing active buffer pools [96](#)
 - listing buffer pools used by a thread [67](#)
 - management [97](#)
 - viewing
 - buffer pool used by a thread [68](#)
 - current values [144](#)
 - statistics [97](#)
- Buffer Pool Detail window [68](#)
- Buffer Pool windows [97](#)

C

- capacity planning [160](#)
- class 5 IFI times and events
 - thread activity [74](#)
- class, trace
 - Online Monitor [14](#)
- COLLECT command [20](#)
- command
 - AUTO
 - statistics [127](#)
 - thread activity [80](#)
 - COLLECT [20](#)
 - DB2 command [18](#)
 - DELTA
 - invoking delta processing mode [91](#)

- command (*continued*)
 - DELTA (*continued*)
 - statistics [128](#)
 - EXPLAIN [81](#), [141](#)
 - HISTORY
 - combined with delta processing [129](#)
 - combined with interval processing [129](#)
 - statistics [129](#)
 - thread activity [82](#)
 - INTERVAL
 - invoking interval processing mode [91](#)
 - statistics [129](#)
 - LOOK [39](#)
 - OPTIONS [20](#)
 - PANELID [18](#)
 - PURGE [83](#)
 - QUALIFY [84](#)
 - REINIT [38](#)
 - RESET
 - returning to regular processing mode [91](#)
 - statistics [129](#)
 - thread activity [83](#)
 - SORT [87](#)
 - source EXPLAIN [144](#)
 - statistics [127](#), [129](#)
 - system parameters [145](#)
 - thread activity [80](#), [89](#)
 - understanding syntax diagrams [1](#)
- command not found [161](#)
- Command Output window [19](#)
- Command window [19](#)
- Commands window [116](#)
- common errors [161](#)
- conventions [2](#)
- cookie policy [201](#), [203](#)
- correlation translation
 - default translation [21](#)
- coupling read requests [125](#)
- CPU time
 - statistics [115](#)
- CPU times and Other Data window [115](#)
- Create Plan Table window [132](#)
- Current DBRM window [57](#)
- Current Package window [55](#)
- Current SQLID window [13](#)

D

- data capture
 - statistics
 - viewing [119](#)
 - thread activity [74](#)
 - viewing statistics [119](#)
- Data Capture window [119](#)
- data collector
 - viewing
 - past statistics [129](#)

- data collector (*continued*)
 - viewing (*continued*)
 - past thread activity [82](#)
- data set
 - exception processing output [43](#)
 - viewing activity [103](#)
- Data Set Maintenance menu
 - defining exception thresholds [146](#)
- data sharing locking
 - statistics
 - viewing [119](#)
 - thread activity [77](#)
 - viewing statistics [119](#)
- Data Sharing Locking Activity window [77](#)
- Data Sharing Locking window
 - statistics [119](#)
 - thread activity [77](#)
- database access thread (DBAT)
 - maximum number concurrently active [114](#)
- database request module (DBRM), explaining [137](#)
- date format
 - Online Monitor [23](#)
- DB2 command
 - description [18](#)
 - displaying the total number of commands executed [116](#)
- DB2 Command Output window [19](#)
- DB2 Command window [19](#)
- DB2 Commands window [116](#)
- DB2 Explain Output panel [139](#)
- DB2 IFC Destinations window [118](#)
- DB2 instrumentation facility
 - displaying the number of
 - records written [117](#)
 - records written to IFC destinations [118](#)
- DB2 Instrumentation window [117](#)
- DB2 Statistics Detail panel [93](#)
- DB2 subsystem windows [8](#)
- DB2 subsystems, monitoring
 - controlling the writing of monitor output [11](#)
 - exception processing [25](#)
 - exception profiling [27](#)
 - exception report [29](#)
 - identifying unusual situations [27](#)
 - performance objectives [27](#)
 - tuning the operating environment [27](#)
- DB2 System Parameters panel [145](#)
- DB2 Thread Qualification Parameters window [85](#)
- DB2 Thread Sort Specification window [89](#)
- DBAT (database access thread)
 - maximum number concurrently active [114](#)
- DBRM (database request module)
 - explaining [137](#)
- DBRM (database request module), explaining [137](#)
- DBRM and Plan List panel [138](#)
- DBRM SQL Statement window [137](#)
- DDF (Distributed Data Facility)
 - listing locations communicating with a thread [72](#)
 - viewing
 - location communicating with a thread [72](#)
 - statistics on remote data [114](#)
 - subsystem-wide activity [113](#)
 - thread conversation [73](#)
- DELTA command
 - invoking delta processing mode [91](#)
- DELTA command (*continued*)
 - statistics [128](#)
- delta processing
 - combined with HISTORY command [129](#)
 - delta value [90](#)
 - description [91](#)
 - resetting delta mode [129](#)
- DGOFOPTS panel [12](#)
- DGOMCCMD panel [19](#)
- DGOMCDCO panel [19](#)
- DGOMDMMU panel [14](#)
- DGOMDPMN panel [8](#)
- DGOMDWAD panel [12](#)
- DGOMDWHD panel [10](#)
- DGOMDWMO panel [11](#)
- DGOMDWSS panel [13](#)
- DGOMEPE02 panel [35](#), [148](#)
- DGOMEPE03 panel [37](#)
- DGOMEPE1 panel [34](#)
- DGOMGP01 panel [15](#)
- DGOMHWHY panel [31](#)
- DGOMLAFS panel [41](#)
- DGOMLAMP panel [40](#)
- DGOMLAXP panel [39](#)
- DGOMLED0 panel [159](#)
- DGOMLEMP panel [42](#)
- DGOMLEXP panel [42](#)
- DGOMLMSP panel [39](#)
- DGOMLSXP panel [41](#)
- DGOMSPSM panel [93](#)
- DGOMSWBC panel [125](#)
- DGOMSWBD panel [126](#)
- DGOMSWBI panel [103](#)
- DGOMSWBM panel [96](#)
- DGOMSWBR panel [98](#)
- DGOMSWBS panel [99](#)
- DGOMSWBT panel [100](#)
- DGOMSWBU panel [101](#)
- DGOMSWBV panel [101](#)
- DGOMSWBY panel [97](#)
- DGOMSWCD panel [119](#)
- DGOMSWCM panel [116](#)
- DGOMSWDD panel [113](#)
- DGOMSWEP panel [95](#)
- DGOMSWGB panel [122](#)
- DGOMSWG D panel [122](#)
- DGOMSWIF panel [118](#)
- DGOMSWIN panel [117](#)
- DGOMSWLG panel [105](#)
- DGOMSWLK panel [101](#)
- DGOMSWOC panel [103](#)
- DGOMSWOT panel [115](#)
- DGOMSWPD panel [111](#)
- DGOMSWQP panel [112](#)
- DGOMSWRL panel [114](#)
- DGOMSWRP panel [113](#)
- DGOMSWSL panel [119](#)
- DGOMSWSP panel [127](#)
- DGOMSWSQ panel [110](#)
- DGOMSWSS panel [107](#)
- DGOMSWSV panel [104](#)
- DGOMTCPR panel [83](#), [84](#)
- DGOMTPLS panel [48](#), [155](#)
- DGOMTPSM panel [51](#)

- DGOMTWBD panel [68](#)
- DGOMTWBM panel [67](#)
- DGOMTWCD panel [74](#)
- DGOMTWCS panel [70](#)
- DGOMTWDB panel [57](#)
- DGOMTWDC panel [73](#)
- DGOMTWDD panel [72](#)
- DGOMTWDL panel [72](#)
- DGOMTWGB panel [78](#)
- DGOMTWGD panel [78](#)
- DGOMTWID panel [53](#)
- DGOMTWLD panel [62](#)
- DGOMTWLK panel [60](#)
- DGOMTWMV panel [55](#)
- DGOMTWPK panel [55](#)
- DGOMTWQ5 panel [85](#)
- DGOMTWQP panel [75](#)
- DGOMTWR panel [63](#)
- DGOMTWRP panel [64](#)
- DGOMTWSL panel [77](#)
- DGOMTWSP panel [79](#)
- DGOMTWSQ panel [65](#)
- DGOMTWSS panel [89](#)
- DGOMTWTI panel [58](#)
- DGOMYPKM panel [139](#)
- DGOMYPMN panel [133](#)
- DGOMYWDL panel [138](#)
- DGOMYWDQ panel [138](#)
- DGOMYWDS panel [137](#)
- DGOMYWES panel [138](#)
- DGOMYWII panel [154](#)
- DGOMYWKQ panel [136](#)
- DGOMYWKS panel [135](#)
- DGOMYWKV panel [136](#)
- DGOMYWPE panel [134](#)
- DGOMYWPL panel [135](#)
- DGOMYWQC panel [132](#)
- DGOMYWQU panel [132](#)
- DGOMYWSS panel [144](#)
- DGOMYWTI panel [154](#)
- DGOMZPSM panel [145](#)
- DGOPMENU panel
 - defining exception thresholds [146](#)
- Display Exception List window [41](#)
- display exception processing
 - description [32](#)
 - starting [38](#)
 - viewing exceptions [41](#)
- Distributed Conversation Detail window [73](#)
- Distributed Data window
 - statistics [113](#)
 - thread activity [72](#)
- Distributed Location Detail window [72](#)
- DPMOUT data set
 - exception processing [44](#)
 - specifying exception processor name [37](#)
- DPMPARMS data set
 - CORRDATA member [21](#)
- drain request, viewing number of [103](#)
- DSNZPARM value
 - viewing [144](#)
 - viewing summary [145](#)

E

- EDM Pool window [95](#)
- elapsed time format
 - Online Monitor [22](#)
- errors
 - command not found [161](#)
 - insufficient storage to display thread activity information [161](#)
 - STEPLIB missing from IRF-generated JCL [161](#)
- exception DPMOUT data set
 - attributes [11](#), [44](#)
- Exception Event Messages window [42](#)
- exception event processing
 - description [33](#)
 - listing messages [42](#)
 - starting [38](#)
 - viewing events [42](#)
- Exception Event Summary window [42](#)
- Exception Log File data set
 - attributes [43](#)
 - description [43](#)
 - output record layout [197](#)
 - printing [43](#)
 - sample files [43](#)
 - specifying processor name [37](#)
- Exception Log File print utility [43](#)
- Exception Notification window [34](#)
- Exception Output Data Sets window [37](#)
- exception processing
 - activating and deactivating [35](#), [148](#)
 - description [32](#)
 - difference between Online Monitor and batch processing [34](#)
 - display exception
 - description [32](#)
 - starting [38](#)
 - viewing [41](#)
 - exception event
 - description [33](#)
 - starting [38](#)
 - viewing [42](#)
 - modes [32](#)
 - output data set [43](#)
 - performance problem identification
 - example [146](#)
 - periodic exception
 - description [33](#)
 - listing messages [40](#)
 - starting [38](#)
 - viewing [39](#)
 - restarting [38](#)
 - starting [35](#), [38](#)
 - starting from Exception Processor panel [35](#)
 - starting with OMEGAMON Collector [35](#)
 - stopping [44](#)
 - viewing messages and status [39](#), [43](#)
 - viewing past data [33](#)
- exception processing user exit [36](#)
- Exception Processor panel [35](#), [148](#)
- exception profiling
 - performance problem identification [27](#)
- exception report
 - monitoring [29](#)

- exception threshold
 - defining [35](#)
- Exception Threshold data set
 - building [36](#)
 - maintaining [7](#)
 - reinitializing [35](#)
 - specifying in Exception Processor panel [36](#)
 - specifying thresholds in [35](#)
 - threshold values in [32](#)
 - using at OMEGAMON Collector startup [35](#)
- EXCEPTIONEVENT
 - OMEGAMON Collector startup parameter [35](#)
- EXEC
 - FPEJINIT [6](#), [26](#)
- Expand function key for scrollable fields [24](#)
- explain
 - authorization [130](#)
 - DBRM [137](#)
 - description [130](#)
 - method [132](#)
 - output [139](#)
 - performance considerations [130](#)
 - plan table considerations [131](#)
 - plan table entry [134](#)
 - process overview [132](#)
 - specifying the SQL statement [138](#)
 - SQL statement [132](#)
 - viewing access path method [139](#)
- EXPLAIN command
 - thread activity [81](#)
- Explain menu [133](#)
- Explain Output panel [139](#)

F

- filtering input [27](#)
- FPEFMENU panel [26](#)
- FPEJINIT EXEC [6](#), [26](#)
- function key
 - commands to change the defaults [18](#)
 - defaults [16](#)
 - for scrollable fields [24](#)

G

- global group buffer pool
 - coupling read requests [125](#), [126](#)
 - Statistics Detail window [126](#)
 - Statistics window [125](#)
- group buffer pool
 - listing pools used by a thread [78](#)
 - listing pools used by DB2 [122](#)
 - viewing
 - group buffer pool used by a thread [78](#)
 - pool used by a DB2 [122](#)
 - statistics on backing coupling activity [126](#)
- Group Buffer Pool Detail window
 - statistics [122](#)
 - thread activity [78](#)
- Group Buffer Pools Activity window
 - statistics [122](#)
 - thread activity [78](#)

H

- high-water mark fields [92](#)
- high-water mark value [89](#)
- history
 - exception processing [33](#)
 - viewing
 - past statistics [129](#)
 - thread history [82](#)
- HISTORY command
 - delta processing mode [129](#)
 - interval processing mode [129](#)
 - statistics [129](#)
 - thread activity [82](#)
- History Defaults window [10](#)
- History panel [31](#)

I

- identifier, OMEGAMON XE for DB2 PE [85](#)
- IFC Destinations window [118](#)
- IFCID 337
 - on Exception Event Summary panel [42](#)
- IFCID 359
 - on Exception Event Summary panel [42](#)
- IFI (class 5) and Data Capture window [74](#)
- IFI times and events
 - thread activity [74](#)
- Index Selection window [154](#)
- Index Split exception event [42](#)
- input
 - Online Monitor [14](#)
 - required [14](#)
- instrumentation facility
 - displaying the number of
 - records written [117](#)
 - records written to IFC destinations [118](#)
- Instrumentation window [117](#)
- insufficient storage to display thread activity information [161](#)
- Interactive Report Facility (IRF)
 - session options [12](#)
- INTERVAL command
 - invoking interval processing mode [91](#)
 - statistics [129](#)
- interval processing
 - combined with HISTORY command [129](#)
 - description [91](#)
 - resetting interval mode [129](#)
- interval processing (Online Monitor)
 - viewing past data [129](#)
- IRF (Interactive Report Facility)
 - invocation of [7](#)
 - session options [12](#)
- ISPF Online Monitor
 - source explain [141](#)

L

- large value
 - Online Monitor [21](#)
- layout
 - Exception Log File data set output [197](#)
- Left function key for scrollable fields [24](#)

- legal notices
 - cookie policy [201](#), [203](#)
 - notices [201](#)
 - programming interface information [201](#), [202](#)
 - trademarks [201–203](#)
- limiting input [27](#)
- Lock Escalation exception event [42](#)
- locked resources
 - listing locked thread resources [62](#)
- Locked Resources window [62](#)
- locking
 - concurrency considerations [62](#), [103](#)
 - performance problem identification example [155](#)
 - statistics
 - viewing [101](#)
 - viewing statistics [101](#)
 - viewing thread activity [60](#)
- Locking (IRLM) Activity window [60](#)
- Locking Activity window [101](#)
- Log Manager window [105](#)
- logs
 - considerations for [107](#)
 - viewing Read and Write activity [105](#)
- LOOK command [39](#)
- Look Selections menu [39](#)

M

- Memory Usage window [14](#)
- menu
 - data set maintenance
 - defining exception thresholds [146](#)
 - Explain [133](#)
 - Look Selections [39](#)
 - Options [8](#)
- message
 - exception processing [39](#), [43](#)
 - FPEM103 [13](#), [161](#)
 - FPEM546 [13](#), [161](#)
 - IKJ56500I [161](#)
- migration
 - plan table [132](#)
- missing value
 - Online Monitor [21](#)
- Monitor Output window [11](#)
- monitoring DB2 subsystems
 - controlling the writing of monitor output [11](#)
 - exception processing [25](#)
 - exception profiling [27](#)
 - exception report [29](#)
 - identifying unusual situations [27](#)
 - performance objectives [27](#)
 - tuning the operating environment [27](#)
- monitoring using reports [28](#)

N

- notices [201](#), [202](#)

O

- OMEGAMON XE for DB2 PE identifier [85](#)
- Online Monitor

- Online Monitor (*continued*)
 - accessing [6](#)
 - description [26](#)
 - overview [5](#)
 - using [6](#), [23](#)
- Online Monitor Memory Usage window [14](#)
- Online Monitor options [8](#)
- Open/Close Management window [103](#)
- options [7](#)
- OPTIONS command [20](#)
- Options menu [8](#)
- overview [1](#)

P

- package
 - explain an SQL statement [135](#)
- Package SQL Statement window [135](#)
- Package Version List panel [136](#)
- panel
 - Asynchronous Task Termination [15](#)
 - Authorization Failure Summary [41](#)
 - DB2 Explain Output [139](#)
 - DB2 Statistics Detail [93](#)
 - DB2 System Parameters [145](#)
 - Exception Event Messages [42](#)
 - Exception Event Summary [42](#)
 - Exception Processor [35](#), [148](#)
 - FPEFMENU [26](#)
 - moving between Online Monitor panels [14](#)
 - moving between panels [14](#)
 - SQL Statement List (packages) [136](#)
 - SQL Statement Selection [144](#)
 - SQL Text Edit [139](#)
 - statistics [93](#)
 - Thread Summary [48](#), [155](#)
- PANELID command [18](#)
- parallelism
 - considerations [47](#)
- parameter
 - IFIRALEN [161](#)
- parameter data set
 - Interactive Report Facility [7](#)
- past data
 - exception processing [33](#)
 - viewing
 - past statistics [129](#)
 - thread history [82](#)
- performance data
 - viewing [93](#)
- performance data, viewing [93](#)
- performance problem identification
 - Accounting times [46](#)
 - controlling the writing of monitor output [11](#)
 - deadlock resolution [159](#), [160](#)
 - examples
 - exception processing [146](#)
 - lock suspension [155](#)
 - exception processing [25](#)
 - exception profiling [27](#)
 - exception report [29](#)
 - identifying unusual situations [27](#)
 - performance objectives [27](#)
 - tuning the operating environment [27](#)

- Periodic Exception Messages window [40](#)
- periodic exception processing
 - description [33](#)
 - listing messages [40](#)
 - starting [38](#)
 - viewing exceptions [39](#)
- Periodic Exceptions List window [39](#)
- Plan and Package Allocation window [104](#)
- plan table
 - considerations [131](#)
 - explaining existing entry [134](#)
 - upgrading [132](#)
- Plan Table Entry List panel [135](#)
- Plan Table Entry window [134](#)
- plan/package processing
 - viewing allocations [104](#)
- profile data set, member
 - FPEFPROF [161](#)
- programming interface information [201](#), [202](#)
- PURGE command [83](#)
- Purge Thread Confirmation window [83](#), [84](#)

Q

- QUALIFY command [84](#)
- query parallelism
 - special considerations [76](#)
 - statistics
 - viewing [112](#)
 - thread activity [75](#)
 - viewing statistics [112](#)
- Query Parallelism Data window
 - statistics [112](#)
 - thread activity [75](#)

R

- regular processing mode [91](#)
- REINIT command [38](#)
- Remote Location window [114](#)
- Requester Correlation Data window [55](#)
- RESET command
 - returning to regular processing mode [91](#)
 - statistics [129](#)
 - thread activity [83](#)
- response time
 - thread activity [46](#)
 - viewing for a thread [58](#)
- restrictions [14](#)
- RID list processing
 - displaying the number of
 - blocks allocated [113](#)
 - operations [64](#)
 - terminations [113](#)
- Rid List Processing window
 - statistics [113](#)
 - thread activity [64](#)
- Right function key for scrollable fields [24](#)
- RKO2SAMP library
 - DGOECFIL member [43](#)
 - DGOELFIL member [44](#)
 - DGOEQFIL member [44](#)
 - DGOEVFIL member [44](#)

RKO2SAMP library (*continued*)

- DGOMEJCL member [43](#)
- DGOMMJCL member [32](#)

S

- sample file
 - Exception Log File data set [43](#)
- screen readers and magnifiers [4](#)
- scrollable field
 - examples [23](#)
- scrollable field support [23](#)
- service information [1](#)
- Session Options window [12](#)
- snapshot fields [92](#)
- snapshot value [89](#)
- SORT command [87](#)
- source explain
 - ISPF Online Monitor [141](#)
- source EXPLAIN command [144](#)
- Source Explain Options window [142](#)
- SQL
 - viewing subsystem-wide activity [110](#)
- SQL activity
 - viewing subsystem-wide activity [110](#)
- SQL Activity window
 - statistics [110](#)
 - thread activity [65](#)
- SQL statement
 - displaying the number of statements executed for a thread [65](#)
 - EXPLAIN command [81](#)
 - explain function [130](#)
 - viewing thread details [69](#)
- SQL Statement and Package window [70](#)
- SQL Statement List panel (DBRMs) [138](#)
- SQL Statement List panel (packages) [136](#)
- SQL Statement Selection panel [144](#)
- SQL Text Edit panel [139](#)
- SQL Text Entry window [138](#)
- SQLID window [13](#)
- starting
 - OMEGAMON XE for DB2 PE [6](#), [26](#)
- statistics
 - commands
 - AUTO [127](#)
 - DELTA [128](#)
 - HISTORY [129](#)
 - INTERVAL [129](#)
 - RESET [129](#)
 - displaying the number of
 - DB2 commands executed [116](#)
 - instrumentation records [117](#)
 - instrumentation records written to IFC destinations [118](#)
 - high-water mark fields [92](#)
 - listing active buffer pools [96](#)
 - listing group buffer pools used by DB2 [122](#)
 - panel overview [93](#)
 - processing mode
 - delta mode [91](#)
 - interval mode [91](#)

statistics (*continued*)

- processing mode (*continued*)
 - regular mode [91](#)
 - resetting delta or interval mode [129](#)
- refreshing panel values [127](#)
- RID list processing [113](#)
- snapshot fields [92](#)
- viewing
 - accumulated data [129](#)
 - active buffer pool [97](#)
 - activity on calls to user-written SQL programs at DB2 server [127](#)
 - backing coupling activity [126](#)
 - bind processing [103](#)
 - CPU times and other data [115](#)
 - data capture activity [119](#)
 - data distributed by a remote location [114](#)
 - data set activity and drain requests [103](#)
 - data sharing locking activity [119](#)
 - EDM pool efficiency [95](#)
 - group buffer pool used by DB2 [122](#)
 - key performance data [93](#)
 - locking activity [101](#)
 - log activity [105](#)
 - past data [129](#)
 - plan and package allocation and authorization management [104](#)
 - query parallelism [112](#)
 - subsystem-wide DB2 activity [107](#), [128](#)
 - subsystem-wide DDF activity [113](#)
 - subsystem-wide SQL activity [110](#)

Statistics Detail panel [93](#)

status

- exception processing [39](#), [43](#)

STEPLIB missing from IRF-generated JCL [161](#)

stored procedures

- viewing activity on calls to user-written SQL programs at DB2 server [127](#)
- viewing for a thread [79](#)

Stored Procedures window

- statistics [127](#)
- thread activity [79](#)

Subsystem Service window [107](#)

subsystem services

- viewing subsystem-wide DB2 activity [107](#)

support information [1](#)

syntax [18](#), [20](#), [31](#), [38](#), [39](#), [80–84](#), [87](#), [127–129](#), [144](#)

syntax diagram

- source EXPLAIN [144](#)

syntax diagrams [1](#)

system parameters [6](#)

System Parameters panel [145](#)

system parameters reports

- commands [145](#)
- viewing [144](#)

T

Table Information window [154](#)

terminology used [3](#)

thread

- Accounting times [46](#)

thread (*continued*)

- ACQUIRE and RELEASE to reduce thread creation costs [109](#)

commands

- AUTO [80](#)
- EXPLAIN [81](#)
- HISTORY [82](#)
- PURGE [83](#)
- QUALIFY [84](#)
- RESET [83](#)
- SORT [87](#)

disabling thread in Thread Summary panel [83](#)

displaying [44](#)

displaying the number of

- RID list processing operations [64](#)
- SQL statements executed [65](#)

filtering threads in Thread Summary panel [84](#)

limiting display in Thread Summary panel [84](#)

listing

- active threads [48](#)
- buffer pools used [67](#)
- distributed data [72](#)
- group buffer pools used [78](#)
- locked thread resources [62](#)

ordering threads in Thread Summary panel [87](#)

purging a thread [83](#)

refreshing panel values [80](#)

reuse considerations [108](#)

thread activity overview [45](#)

viewing

- buffer pool [68](#)
- DBRM information [57](#)
- distributed conversation [73](#)
- group buffer pool used [78](#)
- IFI calls and data capture information [74](#)
- locked thread resource [63](#)
- locking activity [60](#)
- package information [55](#)
- past data [82](#)
- query parallelism information [75](#)
- requester correlation data [55](#)
- response time [58](#)
- specific distributed data [72](#)
- SQL statement information [69](#)
- stored procedures [79](#)
- thread details [51](#)
- thread identification [53](#)

thread activity

- performance problem identification example [155](#)

Thread Detail panel [51](#)

Thread Identification window [53](#)

thread performance

- parallelism considerations [47](#)

Thread Qualification Parameters window [85](#)

Thread Sort Specification window [89](#)

Thread Summary panel

- disabling threads [83](#)
- limiting the number of threads displayed [84](#)
- ordering threads [87](#)
- QUALIFY command [84](#)
- RESET command [83](#)
- SORT command [87](#)

Thread Times window [58](#)

Threads Holding Resource window [63](#)

- time
 - class 5
 - thread activity [74](#)
- time class [5 74](#)
- time format
 - Online Monitor [22](#)
- time, class [5 74](#)
- toleration mode
 - IFCID [337 42](#)
 - IFCID [359 42](#)
- trace class
 - Online Monitor [14](#)
- trademarks [201–203](#)

U

- Upgrade Plan Table window [132](#)

V

- value
 - delta [90](#)
 - DSNZPARM [144](#)
 - high-water mark [89](#)
 - large and missing [21](#)
 - Online Monitor [21](#)
 - refreshing
 - Online Monitor values periodically [11](#)
 - statistics values (AUTO command) [127](#)
 - thread activity values (AUTO command) [80](#)
 - snapshot [89](#)
 - viewing current buffer pool values [144](#)
- viewing past data [30](#)

W

- window
 - Auto Display [12](#)
 - backing detail facility [126](#)
 - Bind Processing [103](#)
 - Buffer Manager [96](#)
 - Buffer Manager Activity [67](#)
 - Buffer Pool [97](#)
 - Buffer Pool Detail [68](#)
 - CPU times and Other Data [115](#)
 - Create Plan Table [132](#)
 - Current DBRM [57](#)
 - Current Package [55](#)
 - Current SQLID [13](#)
 - Data Capture [119](#)
 - data sharing locking activity
 - statistics [119](#)
 - Data Sharing Locking Activity [77](#)
 - DB2 Command [19](#)
 - DB2 Command Output [19](#)
 - DB2 Commands [116](#)
 - DB2 IFC Destinations [118](#)
 - DB2 Instrumentation [117](#)
 - DB2 Thread Qualification Parameters [85](#)
 - DB2 Thread Sort Specification [89](#)
 - DBRM and Plan List [138](#)
 - DBRM SQL Statement [137](#)
 - Display Exception List [41](#)

- window (*continued*)

- Distributed Conversation Detail [73](#)
- distributed data
 - statistics [113](#)
 - thread activity [72](#)
- Distributed Location [72](#)
- EDM Pool [95](#)
- Exception Notification [34](#)
- Exception Output Data Sets [37](#)
- Global Group Buffer Pool Statistics [125](#)
- group buffer pool detail
 - statistics [122](#)
 - thread activity [78](#)
- group buffer pools activity
 - statistics [122](#)
 - thread activity [78](#)
- History [31](#)
- History Defaults [10](#)
- IFI (class 5) and Data Capture [74](#)
- Index Selection [154](#)
- Locked Resources [62](#)
- Locking (IRLM) Activity [60](#)
- Locking Activity [101](#)
- Log Manager [105](#)
- Monitor Output [11](#)
- Online Monitor Memory Usage [14](#)
- Open/Close Management [103](#)
- Package SQL Statement [135](#)
- Package Version List [136](#)
- Periodic Exception Messages [40](#)
- Periodic Exceptions List [39](#)
- Plan and Package Allocation [104](#)
- Plan Table Entry [134](#)
- Plan Table Entry List [135](#)
- PREPARE Detail [111](#)
- Purge Thread Confirmation [83, 84](#)
- query parallelism data
 - statistics [112](#)
 - thread activity [75](#)
- Remote Location [114](#)
- Requester Correlation Data [55](#)
- RID list processing
 - statistics [113](#)
 - thread activity [64](#)
- Session Options [12](#)
- SQL activity
 - statistics [110](#)
 - thread activity [65](#)
- SQL Statement and Package [70](#)
- SQL Statement List (DBRMs) [138](#)
- SQL Text Entry [138](#)
- stored procedure
 - statistics [127](#)
 - thread activity [79](#)
- Subsystem Service [107](#)
- Table Information [154](#)
- Thread Identification [53](#)
- Thread Times [58](#)
- Threads Holding Resource [63](#)
- Upgrade Plan Table [132](#)



Product Number: 5655-W37

SH12-7070

