

CICS Transaction Server for z/OS  
5.5

*Using EXCI*



**Note**

Before using this information and the product it supports, read the information in [“Notices” on page 123.](#)

This edition applies to the IBM® CICS® Transaction Server for z/OS® Version 5 Release 5 (product number 5655-Y04) and to all subsequent releases and modifications until otherwise indicated in new editions.

© **Copyright International Business Machines Corporation 1974, 2023.**

US Government Users Restricted Rights – Use, duplication or disclosure restricted by GSA ADP Schedule Contract with IBM Corp.

---

# Contents

<b>About this PDF.....</b>	<b>vii</b>
<b>Chapter 1. EXCI concepts.....</b>	<b>1</b>
<b>Chapter 2. Introduction to the external CICS interface.....</b>	<b>3</b>
The EXCI programming interfaces.....	4
Choosing between the EXEC CICS and the CALL interface.....	5
Illustrations of the external CICS CALL interface .....	5
Illustration of the EXCI EXEC CICS interface.....	7
Resource recovery.....	8
Use of RRMS with the external CICS interface .....	8
Use of sync points in the client program.....	11
The EXCI CALL interface.....	11
The EXCI CALL interface commands.....	11
EXCI call response code values.....	31
Return area for the EXCI CALL interface.....	32
Example of EXCI CALL with null parameters.....	33
The EXCI EXEC CICS interface.....	34
EXEC CICS LINK command (EXCI).....	35
EXEC CICS DELETE CHANNEL command (EXCI).....	42
EXEC CICS DELETE CONTAINER command (EXCI).....	43
EXEC CICS ENDBROWSE CONTAINER command (EXCI).....	44
EXEC CICS GET CONTAINER command (EXCI).....	45
EXEC CICS GETNEXT CONTAINER command (EXCI).....	49
EXEC CICS MOVE CONTAINER command (EXCI).....	50
EXEC CICS PUT CONTAINER command (EXCI).....	52
EXEC CICS QUERY CHANNEL command (EXCI).....	55
EXEC CICS STARTBROWSE CONTAINER command (EXCI).....	56
Compiling and link-editing EXCI client programs.....	57
Job control language to run an EXCI client program.....	57
EXCI programming considerations.....	59
<b>Chapter 3. Configuring EXCI.....</b>	<b>61</b>
Setting up EXCI for static routing.....	61
Setting up EXCI for dynamic routing.....	61
Defining connections to CICS.....	62
CONNECTION resource definition for EXCI.....	62
SESSIONS resource definitions for EXCI connections.....	63
Inquiring on the state of EXCI connections.....	65
The EXCI user-replaceable module.....	66
Using the EXCI options table, DFHXCOPT.....	67
<b>Chapter 4. Security for EXCI.....</b>	<b>73</b>
Using MRO logon and bind-time security.....	73
Defining DFHAPPL FACILITY class profiles for an EXCI region.....	73
Link security.....	74
User security.....	74
Surrogate user checking.....	75
<b>Chapter 5. Troubleshooting EXCI.....</b>	<b>77</b>

Trace.....	77
Formatting GTF trace.....	77
Using System dumps.....	77
Formatting system dumps.....	77
Capturing SYSMDUMPs.....	78
Using the MVS DUMP command at the console for dumps.....	78
The EXCI service trap, DFHXCTRA.....	78
Problem determination with RRMS.....	79
EXCI trace entry points.....	79

## **Chapter 6. Response and reason codes returned on EXCI calls..... 93**

Reason code for response: OK.....	93
0: NORMAL.....	93
Reason codes for response: WARNING.....	93
1: PIPE_ALREADY_OPEN.....	93
2: PIPE_ALREADY_CLOSED.....	93
3: VERIFY_BLOCK_FM_ERROR.....	94
4: WS_FREEMAIN_ERROR.....	94
5: XCPIPE_FREEMAIN_ERROR.....	94
6: IRP_IOAREA_FM_FAILURE.....	94
7: SERVER_TERMINATED.....	95
8: XFRASTG1_FM_FAILURE.....	95
Reason codes for response: RETRYABLE.....	95
201: NO_CICS_IRC_STARTED.....	95
202: NO_PIPE.....	96
203 (on Open_Pipe call): NO_CICS.....	96
204: WRONG_MVS_FOR_RRMS .....	97
205: RRMS_NOT_AVAILABLE.....	97
Reason codes for response: USER_ERROR.....	97
401: INVALID_CALL_TYPE.....	97
402: INVALID_VERSION_NUMBER.....	98
403: INVALID_APPL_NAME.....	98
404: INVALID_USER_TOKEN.....	98
405: PIPE_NOT_CLOSED.....	99
406: PIPE_NOT_OPEN.....	99
407: INVALID_USERID.....	99
408: INVALID_UOWID.....	100
409: INVALID_TRANSID.....	100
410: DFHMEBM_LOAD_FAILED.....	100
411: DFHMET4E_LOAD_FAILED.....	101
412: DFHXCURM_LOAD_FAILED.....	101
413: DFHXCTRA_LOAD_FAILED.....	101
414: IRP_ABORT_RECEIVED.....	102
415: INVALID_CONNECTION_DEFN.....	102
416: INVALID_CICS_RELEASE.....	102
417: PIPE_MUST_CLOSE.....	103
418: INVALID_PIPE_TOKEN.....	103
419: CICS_AFCB_PRESENT.....	103
420: DFHXCLOPT_LOAD_FAILED.....	104
421: RUNNING_UNDER_AN_IRB.....	104
422: SERVER_ABENDED.....	104
423: SURROGATE_CHECK_FAILED.....	105
424: RRMS_NOT_SUPPORTED.....	105
425: UOWID_NOT_ALLOWED .....	105
426: INVALID_TRANSID2.....	105
427: INVALID_CCSID.....	106
428: INVALID_ENDIAN.....	106

429: DFHXCEIX_LOAD_FAILED.....	106
430: DFHXCPRX_LOAD_FAILED.....	107
431: COMMAREA_LEN_NOT_ALLOWED.....	107
432: DATA_LEN_NOT_ALLOWED.....	107
433: CCSID_NOT_ALLOWED.....	108
434: ENDIAN_NOT_ALLOWED.....	108
Reason codes for response: SYSTEM_ERROR.....	108
601: WS_GETMAIN_ERROR.....	108
602: XCGLOBAL_GETMAIN_ERROR.....	109
603: XCUSER_GETMAIN_ERROR.....	109
604: XCPPIPE_GETMAIN_ERROR.....	109
605: VERIFY_BLOCK_GM_ERROR.....	109
606: SSI_VERIFY_FAILED.....	110
607: CICS_SVC_CALL_FAILURE.....	110
608: IRC_LOGON_FAILURE.....	110
609: IRC_CONNECT_FAILURE.....	111
610: IRC_DISCONNECT_FAILURE.....	111
611: IRC_LOGOFF_FAILURE.....	111
612: TRANSFORM_1_ERROR.....	112
613: TRANSFORM_4_ERROR.....	112
614: IRP_NULL_DATA_RECEIVED.....	112
615: IRP_NEGATIVE_RESPONSE.....	112
616: IRP_SWITCH_PULL_FAILURE.....	113
617: IRP_IOAREA_GM_FAILURE.....	113
619: IRP_BAD_IOAREA.....	113
620: IRP_PROTOCOL_ERROR.....	114
621: PIPE_RECOVERY_FAILURE.....	114
622: ESTAE_SETUP_FAILURE.....	114
623: ESTAE_INVOKED.....	115
624: SERVER_TIMEDOUT.....	115
625: STIMER_SETUP_FAILURE.....	115
626: STIMER_CANCEL_FAILURE.....	116
627: INCORRECT_SVC_LEVEL.....	116
628: IRP_LEVEL_CHECK_FAILURE.....	116
629: SERVER_PROTOCOL_ERROR.....	117
630: RRMS_ERROR.....	117
631: RRMS_SEVERE_ERROR.....	117
632: XCGUR_GETMAIN_ERROR.....	118
633: INQUIRE_CHANNEL_FAILED.....	118

**Chapter 7. EXCI samples: channel and containers sample applications..... 119**

About the EXCI channel and containers sample applications.....	119
Setting up the EXCI channel and containers sample programs.....	120
Running the EXCI channel and containers sample applications.....	121

**Notices..... 123**

**Index..... 129**



## About this PDF

---

This PDF describes how you can use the EXternal CICS Interface (EXCI) to make the services of CICS Transaction Server for z/OS available to external programs. Before CICS TS 5.4, this information was in the *External Interfaces Guide*.

For details of the terms and notation used in this book, see [Conventions and terminology used in the CICS documentation](#) in IBM Knowledge Center.

### **Date of this PDF**

This PDF was created on 2024-04-22 (Year-Month-Date).





---

# Chapter 1. EXCI concepts

The external CICS interface makes CICS applications more easily accessible from non-CICS environments.

Programs running in MVS™ can issue an EXEC CICS LINK PROGRAM command to call a CICS application programs running in a CICS region. Alternatively, the MVS programs can use the CALL interface when it is more appropriate to do so.

The provision of this programming interface means that, for example, MVS programs can:

- Update resources with integrity while CICS is accessing them.
- Take CICS resources offline, and back online, at the start and end of an MVS job. For example, you can:
  - Open and close CICS files.
  - Enable and disable transactions in CICS (and so eliminate the need for a main terminal operator during system backup and recovery procedures).

The external CICS interface opens up a new way to implement client/server applications, where the client program in a non-CICS environment calls a server program running in the CICS address space. The external CICS interface benefits not only TSO and batch applications, but allows you to extend the use of CICS application programs in an open client/server environment.



---

## Chapter 2. Introduction to the external CICS interface

The external CICS interface is an application programming interface that enables a non-CICS program (a client program) running in MVS to call a program (a server program) running in a CICS region and to pass and receive data by using a communications area or by using a channel and a set of containers. The CICS application program is started as if linked to by another CICS application program.

You can use the external CICS interface to allocate and open sessions, or *pipes* (a one-way communication path between a sending process and a receiving process) to a CICS region, and to pass distributed program link (DPL) requests over them. The multiregion operation (MRO) facility of CICS interregion communication (IRC) facility supports these requests, and each pipe maps onto one MRO session, where the client program represents the sending process and the CICS server region represents the receiving process.

There is a default limit of 100 pipes per EXCI address space; the limit can be changed when MVS is IPLed. This limit prevents EXCI clients monopolizing MRO resources, which could prevent CICS regions from using MRO. The limit is applied in both MRO and cross-system MRO (XCF/MRO) environments. An **allocate\_pipe** request results in an **MRO LOGON** request being issued, and there is a limit on the total number of **MRO LOGON** requests allowed from all address spaces. This is critical when you are using XCF/MRO, where the limit on the number of members in an XCF group also limits the total number of **MRO LOGON** requests.

Therefore, when a pipe is no longer needed, you must ensure that the pipe is closed and deallocated. It is the user's responsibility to ensure that the client program closes and deallocates the pipe that it has opened, before the program terminates. Failure to deallocate pipes can lead to errors resulting from the logon limit being reached.

**Note:** After a successful **Open\_Pipe** request, when your client program finishes using the pipe, you must first issue a **Close\_Pipe** command and then a **Deallocate\_Pipe** command to free the pipe. If you issue a **Deallocate\_Pipe** command without first closing an open pipe with **Close\_Pipe**, your request fails with **USER\_ERROR (RC12)** with reason code **405 PIPE\_NOT\_CLOSED**.

If your **Open\_Pipe** request fails, it is recommended to deallocate the pipe to avoid the logon limit being reached.

The external CICS interface identifies the CICS region to communicate with by the CICS region APPLID, as defined in the **APPLID** system initialization parameter. You can specify the APPLID either on an EXCI API call or by using the DFHXCURM user-replaceable program. You can also use DFHXCURM to change the value of XCFGROUP to be used on an **allocate\_pipe** request. For more information about DFHXCURM, see [The EXCI user-replaceable module](#).

**Note:** Do not confuse the term *generic APPLID* with *generic resource name*. Generic resource names apply only to z/OS Communications Server generic resource groups, which are not supported by EXCI.

The client program and the CICS server region (the region where the server program runs or is defined) must be in the same MVS image unless under the following conditions:

- The CICS region is running in a sysplex that supports cross-system MRO.
- All DPL requests issued by the client program specify the SYNCONRETURN option.

Alternatively, if there is no local CICS region in the MVS image, you must specify the SVC parameter that the external CICS interface is to use, by coding a CICSVC parameter in the DFHXCOPT table. Although the external CICS interface does not support the cross-memory access method, it can use the XCF access method provided by the CICS XCF/MRO facility. See [Using the EXCI options table, DFHXCOPT](#) for information about XCF/MRO.

A client program that uses the external CICS interface can operate multiple sessions for different users (either under the same or separate TCBS) all coexisting in the same MVS address space without knowledge of, or interference from, each other.

Where a client program attaches another client program, the attached program runs under its own TCB.

## The EXCI programming interfaces

---

The external CICS interface (EXCI) provides two forms of programming interface: the EXCI CALL interface and the EXEC CICS interface.

### EXCI CALL interface

The EXCI CALL interface consists of six commands that you can use for the following actions:

- Allocate and open sessions to a CICS system from non-CICS programs running under MVS
- Issue DPL requests on these sessions from the non-CICS programs
- Close and deallocate the sessions on completion of the DPL requests.

Here is the list of the six EXCI commands:

- Initialize\_User
- Allocate\_Pipe
- Open\_Pipe
- DPL\_Request
- Close\_Pipe
- Deallocate\_Pipe

For detailed descriptions of these commands and an EXCI CALL example, see [“The EXCI CALL interface” on page 11](#).

### EXEC CICS interface

The EXEC CICS interface provides several commands.

For example, the interface provides a single, composite command, **EXEC CICS LINK PROGRAM**, that performs all six commands of the EXCI CALL interface in one invocation. Each time you issue an **EXEC CICS LINK PROGRAM** command in a client application program, the external CICS interface invokes each of the six EXCI calls on your behalf.

The **EXEC CICS LINK PROGRAM** command is similar but not identical to the distributed program link command of the CICS command-level application programming interface.

EXCI also provides the ability to process data using channel and container commands. A channel together with its set of containers can then be passed on the **EXEC CICS LINK PROGRAM** command or on a call **API DPL\_REQUEST**, as an alternative to using a communications area to transfer data or information from one program to another.

For detailed descriptions of the commands that are available with the EXEC CICS interface, see [“The EXCI EXEC CICS interface” on page 34](#).

**API restrictions for server programs:** A CICS server program invoked by an external CICS interface request is restricted to the DPL subset of the CICS application programming interface. This subset (the DPL subset) of the API commands is the same as for a CICS-to-CICS server program. See [Distributed Program Link \(DPL\)](#) for details of the DPL subset for server programs.

## Choosing between the EXEC CICS and the CALL interface

You can use both the CALL interface (all six commands) and the EXEC CICS LINK command in the same program, to perform separate requests. As a general rule, it is unlikely that you would want to do this in a production program.

[EXCI sample programs](#) illustrates the various language versions of the CICS-supplied sample client program.

Each form of the external CICS interface has its particular benefits.

- For low-frequency or single DPL requests, you are recommended to use the EXEC CICS LINK command.

It is easier to code, and therefore less prone to programming errors.

Note that each invocation of an EXEC CICS LINK command causes the external CICS interface to perform all the functions of the CALL interface, which results in unnecessary overhead.

Note also that this overhead is greatly increased if you use the EXEC CICS LINK command to communicate with a CICS server region in a different LPAR. In this case each invocation of the EXEC CICS LINK command generates a great deal of XCF activity because of the IRP logon, connect, disconnect and logoff which is required. You might find that you experience severe degradation of elapsed time between EXEC CICS LINK commands issued to a CICS server region in a separate LPAR, compared to the elapsed time of the same commands issued to a CICS server region in the same LPAR.

- For multiple or frequent DPL requests from the same client program, you are recommended to use the EXCI CALL interface.

This is more efficient, because you need only perform the Initialize\_User and Allocate\_Pipe commands once, at or near the beginning of your program, and the Deallocate\_Pipe once on completion of all DPL activity. In between these functions, you can open and close the pipe as necessary, and while the pipe is opened, you can issue as many DPL calls as you want.

## Illustrations of the external CICS CALL interface

These four diagrams illustrate the external CICS interface using the EXCI CALL interface.

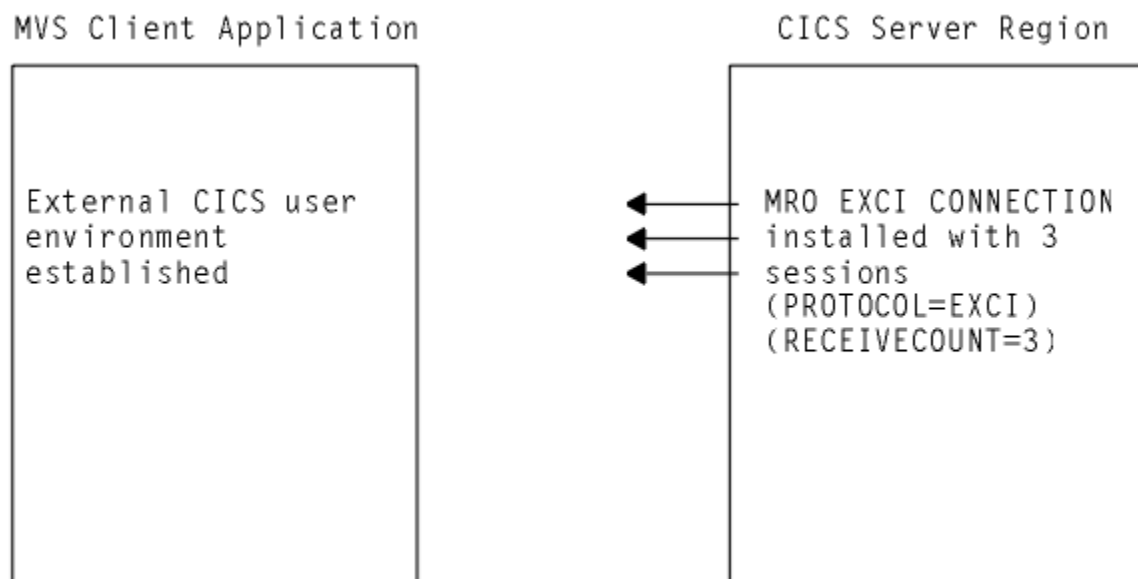

Figure 1. Stage 1: Status after an INITIALIZE\_USER call

### Note:

1. In [Figure 1](#) on page 5, the target CICS region is running with IRC open, and one EXCI connection with three sessions installed, at the time the client application program issues an INITIALIZE\_USER call.

2. The client application program address space is initialized with the EXCI user environment. There is no MRO activity at this stage, and no pipe exists.

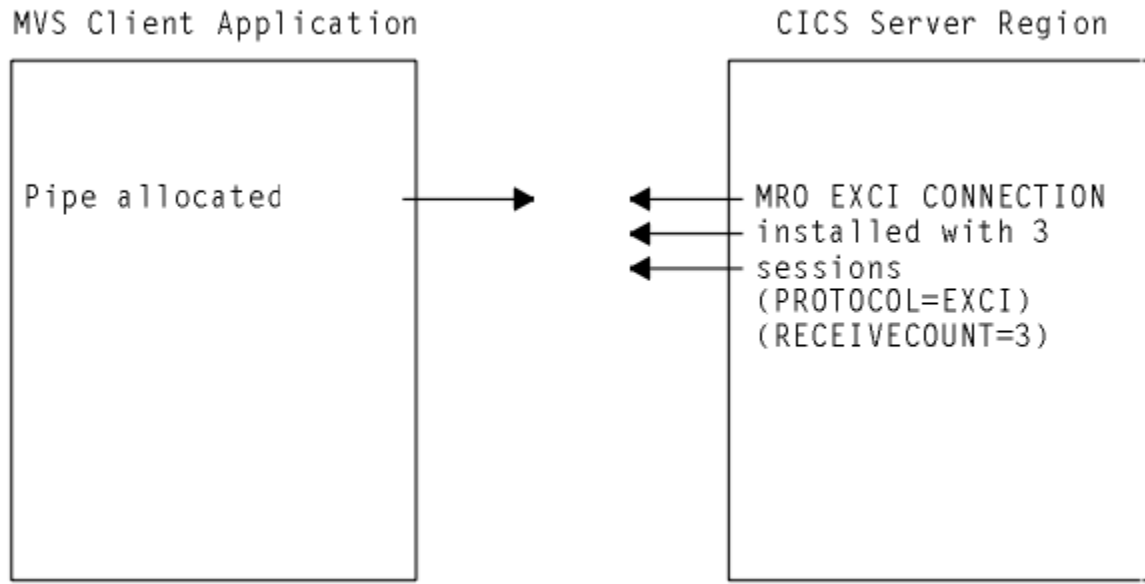

Figure 2. Stage 2: Status after the first ALLOCATE\_PIPE call

**Note:** In [Figure 2 on page 6](#) , the external CICS interface logs on to MRO, identifying the target CICS server region.

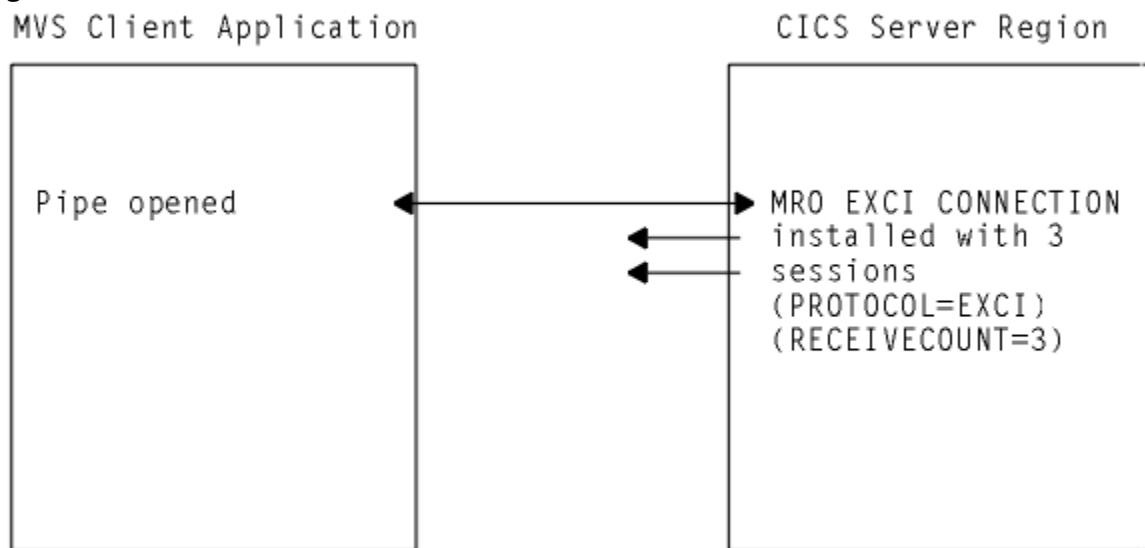

Figure 3. Stage 3: Status after the OPEN\_PIPE call

**Note:**

1. In [Figure 3 on page 6](#) , the external CICS interface connects to the CICS server region, and the pipe is now available for use.
2. The remaining two EXCI sessions are free, and can be used by further open pipe requests from the same, or a different, client application program (provided the connection is generic).

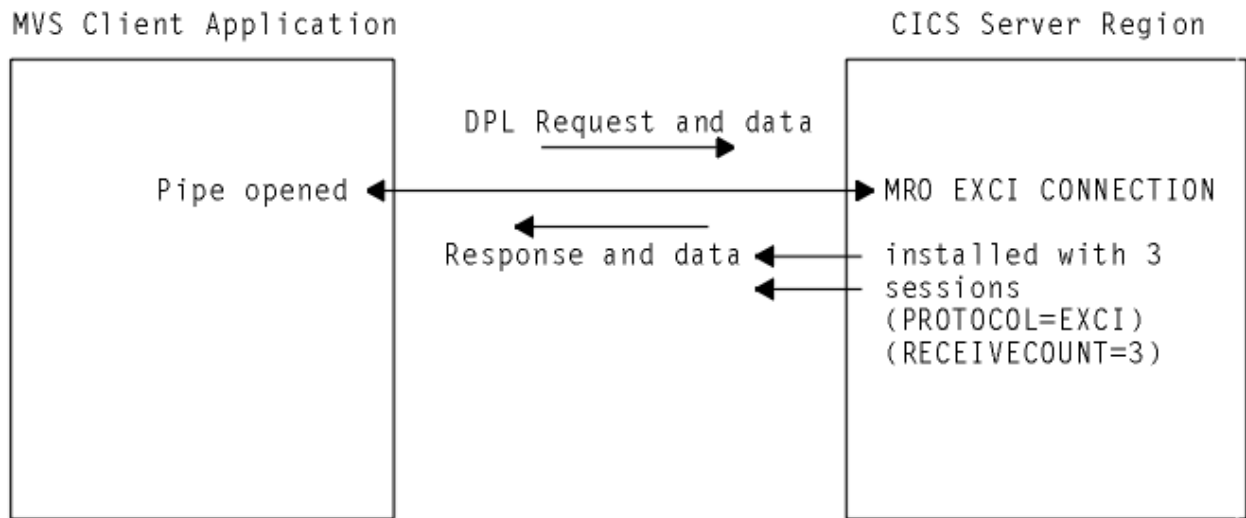

Figure 4. Stage 4: Status with one open pipe, processing a DPL call

**Note:** In Figure 4 on page 7, the external CICS interface passes the DPL request over the open pipe, with any associated data. The CICS server region returns a response and data over the open pipe.

**Closing pipes:** When the client application program closes a pipe, it remains allocated ready for use by the same user, and the status is as shown in Figure 2 on page 6. At this stage, the MRO session is available for use by another open pipe request, from the same or from a different client application program (provided the connection is generic).

**Deallocating pipes:** When the client application program deallocates a pipe, it logs off from MRO and frees all the storage associated with the session. This leaves the status as shown in Figure 1 on page 5.

## Illustration of the EXCI EXEC CICS interface

This diagram illustrates the EXEC CICS interface, and how it resolves to the six EXCI CALLS.

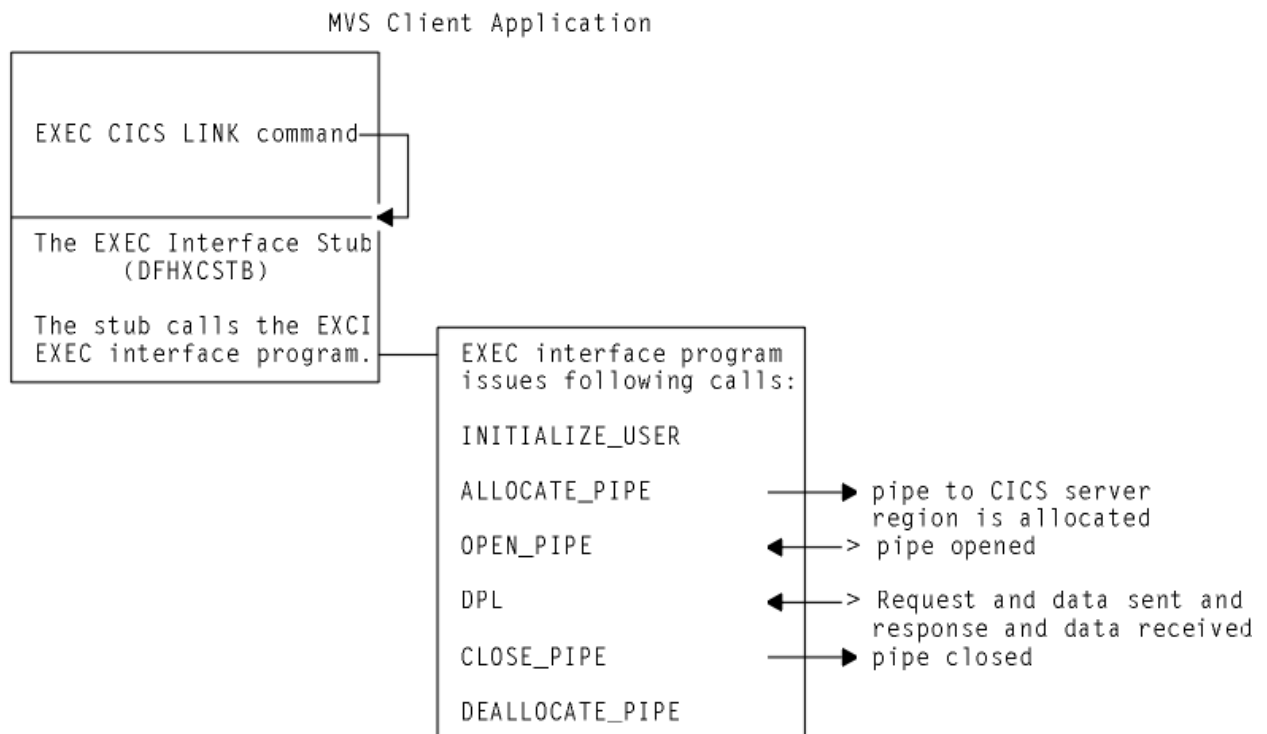

Figure 5. Illustration of the external CICS interface using the EXEC CICS command

## Resource recovery

---

Resource recovery consists of the protocols and program interfaces that allow an application program to make consistent changes to multiple protected resources. The external CICS interface supports resource recovery.

A CICS server program that is invoked by an external CICS interface request can update recoverable resources; the changes are committed when the mirror transaction in the CICS server region takes a sync point. The client program can determine when sync pointing should occur. There are two options:

- Resource recovery controlled by the CICS server regions. In this case, changes to recoverable resources are committed at the completion of each DPL request, independently of the client program. Also, in addition to the sync point taken when the server program returns control to CICS (the SYNCONRETURN option), the server program can take explicit sync points during execution.
- Resource recovery controlled by the EXCI client program with the support of recoverable resource management services (RRMS). When the client program requests it, updates made by the server program in successive DPL requests are committed together.

To support this option, CICS and the external CICS interface both use resource recovery services (RRS), the z/OS sync point manager<sup>1</sup>, which is an MVS component of recoverable resource management services (RRMS). In the context of RRMS, CICS is a **resource manager**; the client program can issue requests to other resource managers, and have resources owned by those resource managers committed in the same **unit-of-recovery (UR)**.<sup>2</sup>

These options are controlled as follows:

- By the DPL\_opts parameter of the DPL\_request.
- By the SYNCONRETURN option, either specified or omitted, on the EXEC CICS LINK PROGRAM command.

If you specify SYNCONRETURN, a sync point is taken on completion of each DPL request. If SYNCONRETURN is omitted, a sync point is taken when the client program requests it using the interfaces described in [“Use of sync points in the client program” on page 11](#).

## Use of RRMS with the external CICS interface

You can use z/OS recoverable resource management services (RRMS) to coordinate distributed program link (DPL) requests.

To use RRMS to coordinate DPL requests, ensure that the following conditions are met:

- The EXCI client and the CICS region to which it sends DPL requests run in the same MVS image. This is an RRMS restriction, and does not apply to DPL requests that specify SYNCONRETURN.
- The CICS region that receives the DPL requests is started with **RRMS=YES** specified as a system initialization parameter (the default is **RRMS=NO**).
- Resource recovery services (RRS) run in the MVS image where CICS and the client program execute. See [z/OS MVS Programming: Resource Recovery](#).

The following figure shows how the external CICS interface and CICS use RRMS. It shows the flow between the MVS batch region that contains the external CICS interface and the EXCI client program, and the CICS server region that contains the CICS mirror and a CICS application program. The numbers on the diagram refer to the principal steps in a unit of recovery (UR), as listed after the figure.

---

<sup>1</sup> RRMS comprises three z/OS components: registration services, context services, and resource recovery services (RRS)

<sup>2</sup> A unit of recovery is analogous to a CICS unit of work



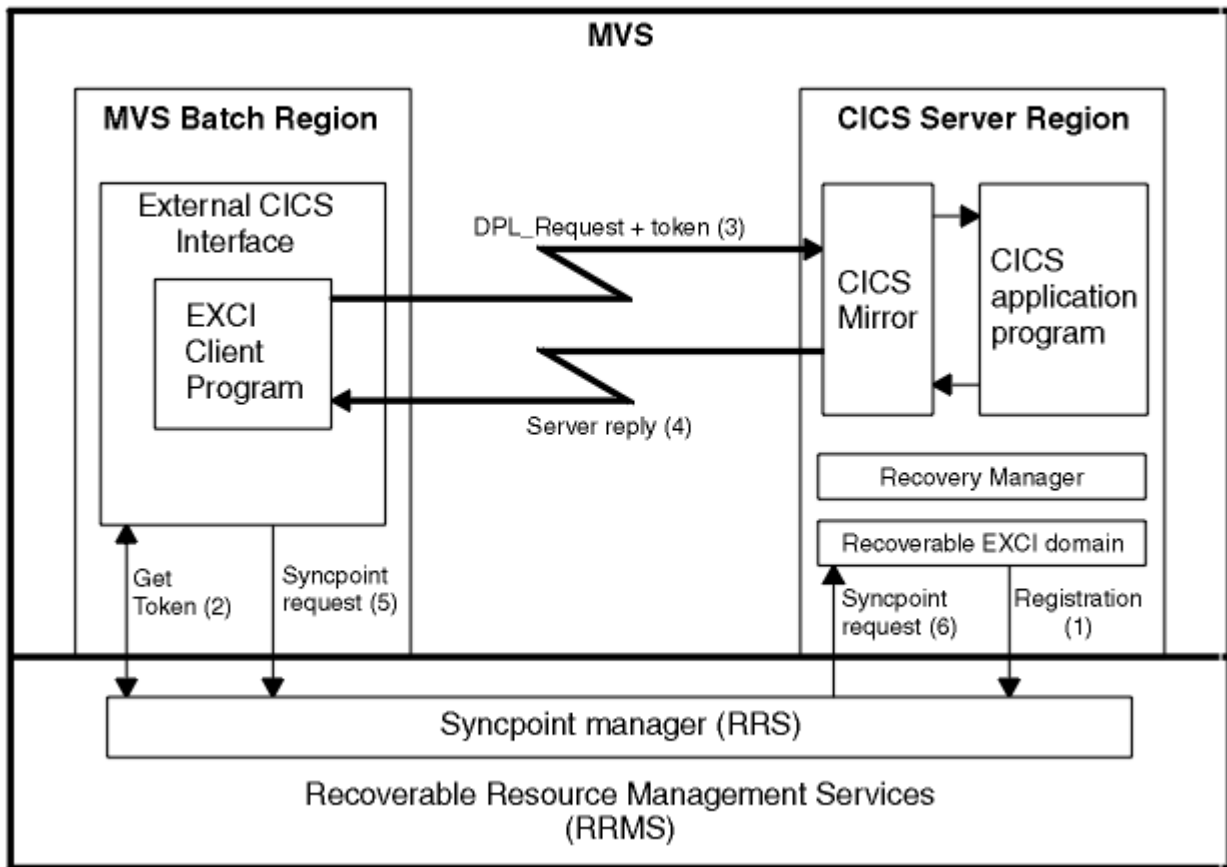

Figure 6. Conceptual view of EXCI client and CICS server region using RRMS

1. If the CICS system initialization parameter **RRMS=YES** is specified, CICS registers with RRMS as a resource manager. This registration occurs during CICS initialization.
2. When the EXCI client program issues a DPL\_Request call in 2-phase commit mode (a call that omits the SYNCONRETURN option), it receives the following from RRMS:
  - A unit-of-recovery identifier (URID)
  - A context token
  - A pass token
3. The URID and the tokens obtained by EXCI on behalf of the client program are included on the DPL request that is passed to the CICS server region. If the DPL request is the first one in the UR, CICS calls RRS to express an interest in the UR, attaches a new mirror transaction, and validates the tokens. If the request is valid, the mirror program links to the specified server application program. The server program completes its work, which is all performed in the UR. This work can include updating recoverable resources in the local server region, or daisy chaining to other CICS regions.
4. When the server program completes, it returns the communications area (COMMAREA) or channels and containers, with return codes, to the client program.

**Note:** Steps 3 and 4 can be repeated many times for the same UR.
5. When the EXCI client program is ready to commit or back out its changes, the program invokes RRS to begin the 2-phase commit protocol.
6. RRS acts as coordinator and completes one of the following actions:
  - RRS asks the resource managers to prepare to commit all updates in the UR. Resource managers other than the CICS server region might also express an interest in the UR. If all vote yes, RRS tells them to go ahead and commit the changes. If any vote no, RRS tells all the resource managers to back out all the changes made in the UR.

- RRS tells all the resource managers that express an interest in the UR to back out all the changes made in the UR.

The UR is now complete and CICS detaches the mirror task. If the EXCI client sends any new DPL requests after this point, EXCI starts a new UR and CICS attaches a new mirror transaction.

Each DPL request that specifies the SYNCONRETURN option attaches a new mirror task in the target CICS region. The first DPL request that does not specify SYNCONRETURN also attaches a new mirror task, but subsequent requests are directed to the same mirror task. When a sync point takes place, the mirror task ends, and the next non-SYNCONRETURN request attaches a new mirror. See [Figure 7 on page 10](#). In this figure, an MVS client application issues DPL requests with and without SYNCONRETURN. The numbers on the figure refer to the principal flow, as listed after the figure.

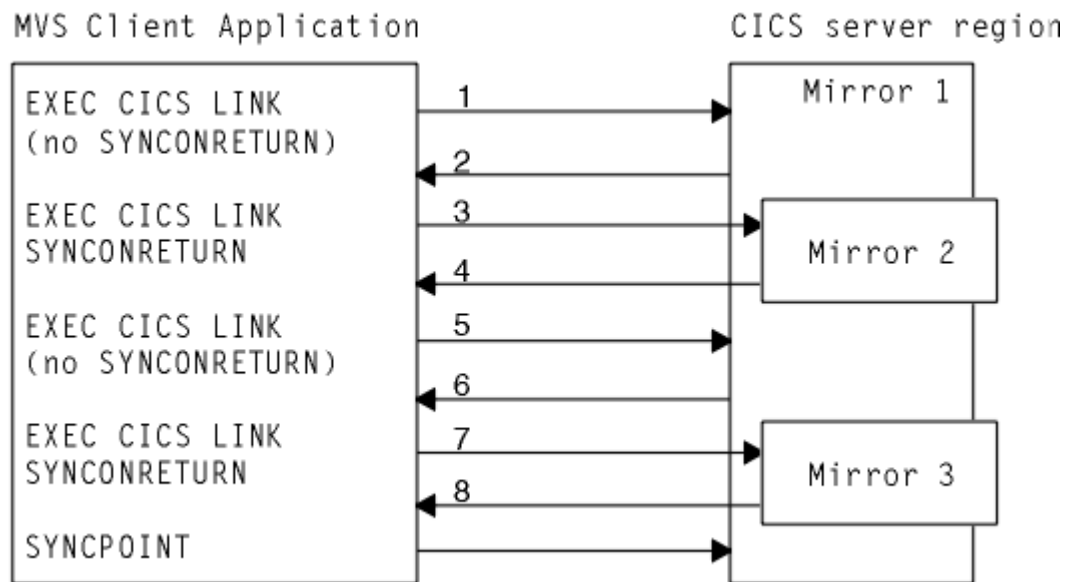

Figure 7. Effect of mixing DPL requests with and without the SYNCONRETURN option

1. Client issues a DPL request without the SYNCONRETURN option.  
Because no mirror transaction is running, a new mirror (Mirror 1) is attached.
2. The DPL request completes, and because it was issued without the SYNCONRETURN option, the mirror transaction waits for another request.
3. Client issues DPL request with the SYNCONRETURN option.  
A new mirror transaction (Mirror 2) is attached.
4. On completion of the DPL request, resources updated by the mirror transaction are committed, and the mirror transaction ends.
5. Client issues another DPL request without the SYNCONRETURN option. Mirror 1 receives and executes the DPL request.
6. The DPL request completes, and once again, the mirror transaction waits for another request.
7. Client issues DPL request with the SYNCONRETURN option.  
A new mirror transaction (Mirror 3) is attached.
8. On completion of the DPL request, resources updated by the mirror transaction are committed, and the mirror transaction ends.
9. The client program requests a syncpoint. Resources updated by mirror 1 are committed, and the transaction ends.

## Use of sync points in the client program

A client program can request that a sync point is taken by using an MVS callable service to commit or back out changes.

To commit changes instigated by the client program, use one of the following MVS callable services:

### **Application\_Commit\_UR (SRRCMIT)**

For a description of Application\_Commit\_UR, see [z/OS MVS Programming: Callable Services for High-Level Languages](#).

### **Commit\_UR (ATRCMIT)**

For a description of Commit\_UR, see [z/OS MVS Programming: Resource Recovery](#).

To back out changes in the client program, use one of the following MVS callable services:

### **Application\_Backout\_UR (SRRBACK)**

For a description of Application\_Backout\_UR, see [z/OS MVS Programming: Callable Services for High-Level Languages](#).

### **Backout\_UR (ATRBACK)**

For a description of Backout\_UR, see [z/OS MVS Programming: Resource Recovery](#).

If none of these interfaces are used, changes are committed or backed out explicitly when the client program either ends normally or abends. It is not advisable to use implicit commit or backout for the following reasons:

- The client program cannot tell whether updates were committed or backed out. Even if the program ends normally, a resource manager might back out any changes.
- The runtime environment for high level languages might intercept errors that would otherwise result in an operating system abend. If such an error is intercepted and the client program does not take any explicit action, the program might terminate normally and updates might be committed. Code your client program to ensure that resources are committed or backed out correctly in these situations. For example, a PL/I program can include an ON unit that issues an **SRRBACK** command when errors are encountered. Similarly, a COBOL program can use the ON phrase on statements that might encounter errors.

## The EXCI CALL interface

---

The EXCI CALL interface consists of six commands that allow you to allocate and open sessions to a CICS system from non-CICS programs running under MVS, to issue distributed program link (DPL) requests on these sessions from the non-CICS programs, and to close and deallocate sessions on completion of DPL requests. This section describes each EXCI CALL command and shows an EXCI CALL example.

### **The application program stub, DFHCSTB**

The EXCI commands invoke the external CICS interface through an application programming stub, called DFHCSTB, provided by CICS. You must include this stub when you link-edit your non-CICS program.

## The EXCI CALL interface commands

In the description of each command that follows, the syntax box illustrates the assembler form of the command. The syntax shows VL,MF=(E,(1)) for each command, indicating the execute form of the CALL macro, with the parameter list storage area addressed by Register 1.

The commands are also supported by C, COBOL, and PL/I programming languages, using the CALL conventions appropriate for these languages.

There are examples of these CALLs, in all the supported languages, in the sample client programs provided by CICS. For more information, see [EXCI sample programs](#).

## Initialize\_User

Initialize the user environment. This includes obtaining authority to use IRC facilities. The environment is created for the lifetime of the TCB, so the command needs to be issued only once per user per TCB. Further commands from this user must be issued under the same TCB.

### Syntax

```
CALL DFHXCIS, (version_number, return_area, user_token, call_type,  
              user_name), VL, MF=(E, (1))
```

### Parameters

#### **version\_number**

A fullword binary input area indicating the version of the external CICS interface parameter list being used. It must be set to 1 in the client program.

The equated value for this parameter in the CICS-supplied copybook DFHXCPL x (where x indicates the language) is VERSION\_1. See [“Return area and function call EQUATE copybooks” on page 32](#) for copybook details.

#### **return\_area**

A 5-word output area to receive response and reason codes, and a message pointer field. For more details see [“Return area for the EXCI CALL interface” on page 32](#).

#### **user\_token**

A 1-word output area containing a 32-bit token supplied by the CICS external interface to represent the client program.

The user token corresponds to the *user-name* parameter. The client program must pass this token on all subsequent external CICS interface commands made for the user defined on the *user\_name* parameter.

#### **call\_type**

A 1-word input area indicating the function of the command. It must be set to 1 in the client program to indicate that this is an Initialize\_User command.

The equated value for this call in the CICS-supplied copybook DFHXCPL x (where x indicates the language) is INIT\_USER. See [“Return area and function call EQUATE copybooks” on page 32](#) for copybook details.

#### **user\_name**

An input area holding a name that identifies the user of the external CICS interface. Generally, this is the client program. If this user is to use a specific pipe, then the value in *user\_name* must match that of the NETNAME attribute of the CONNECTION definition for the specific pipe.

## Responses and reason codes

For all non-zero response codes, a unique reason code value identifies the reason for the response.

**Note:** All numeric response and reason code values are in decimal.

The following is a summary of the response and reason codes that the external CICS interface can return on the Initialize\_User call:

#### **Response OK**

Command executed successfully (RC 0). Reason code:

**0**

Normal response

**Response WARNING**

The command executed successfully, but with an error (RC 4). Reason codes:

**3**

VERIFY\_BLOCK\_FM\_ERROR

Initialize\_User processing requires storage below 16MB to build the parameter list for the SSI Verify call, and an error has occurred during the FREEMAIN for this area.

**4**

WS\_FREEMAIN\_ERROR

An attempt to FREEMAIN working storage has resulted in an MVS FREEMAIN error.

**Response RETRYABLE**

The command failed because of setup errors but can be reissued (RC 8). Reason code:

**201**

NO\_CICS\_IRC\_STARTED

An Initialize\_User command has been issued on an MVS image that has had no IRC activity since the previous IPL, and the external CICS interface cannot determine the CICS SVC number.

**Response USER\_ERROR**

The command failed because of an error in either the client or the server (RC 12). Reason codes:

**401**

INVALID\_CALL\_TYPE

An invalid call-type parameter value is specified on this EXCI request.

**402**

INVALID\_VERSION\_NUMBER

The version\_number parameter does not specify a value of 1 or 2.

**403**

INVALID\_USER\_NAME

The user\_name parameter consists of all blank characters (X'40').

**410**

DFHMEBM\_LOAD\_FAILED

During Initialize\_User processing, the external CICS interface attempted to load the main message module in preparation for issuing external CICS interface messages, and the load of this module failed.

**411**

DFHMET4E\_LOAD\_FAILED

The load of message module, DFHMET4E, has failed. During Initialize\_User processing, the external CICS interface attempted to load its message table in preparation for issuing messages. The load of this module failed.

**412**

DFHXCURM\_LOAD\_FAILED

During Initialize\_User processing, the external CICS interface attempted to load the user-replaceable module, DFHXCURM. The load of this module failed.

**413**

DFHXCTRA\_LOAD\_FAILED

During Initialize\_User processing, the external CICS interface attempted to load the trap module (DFHXCTRA). The load of this module has failed.

**419**

CICS\_AFCB\_PRESENT

An Initialize\_User request has been issued on a TCB that has already been used by CICS or by CICS batch shared database. The external CICS interface cannot share a TCB with CICS , ensuring that a CICS application program cannot issue EXCI requests.

**420**

DFHXCOPT\_LOAD\_FAILED

During Initialize\_User processing, the external CICS interface attempted to load its options module, DFHXCOPT. The load of this module failed.

**421**

RUNNING\_UNDER\_AN\_IRB

The EXCI call is issued under an MVS IRB, which is not permitted.

**422**

SERVER\_ABENDED

While processing a DPL request, the CICS server application program abended without handling the error.

**423**

SURROGATE\_CHECK\_FAILED

A DPL request has been issued specifying a USERID parameter.

**424**

RRMS\_NOT\_SUPPORTED

A DPL request omitting the SYNCONRETURN option has been made on a system that is not running OS/390® Version 2 Release 5 or higher.

**425**

UOWID\_NOT\_ALLOWED

A DPL request omitted the SYNCONRETURN option, but specified a value of UOWID. This combination of parameters is not permitted on a DPL request.

**426**

INVALID\_TRANSID2

A DPL request has been issued with a **TRANSID2** parameter that consists of all blanks.

**427**

INVALID\_CCSD

A DPL request has been issued with a **CCSID** parameter that specifies an invalid value.

**428**

INVALID\_ENDIAN

A DPL request has been issued with a endian parameter that specifies an invalid value.

**429**

DFHXCEIX\_LOAD\_FAILED

During Initialize\_User processing, the external CICS interface attempted to load the module (DFHXCEIX). The load of this module has failed.

**430**

DFHXCPRX\_LOAD\_FAILED

During Initialize\_User processing, the external CICS interface attempted to load the module (DFHXCPRX). The load of this module has failed.

**Response SYSTEM\_ERROR**

The command failed (RC 16). Reason codes:

**601**

WS\_GETMAIN\_ERROR

During Initialize\_User processing, a GETMAIN for working storage failed.

**602**

XCGLOBAL\_GETMAIN\_ERROR

During Initialize\_User processing, a GETMAIN failed for a critical control block (XCGLOBAL).

**603**

XCUSER\_GETMAIN\_ERROR

During Initialize\_User processing, a GETMAIN request failed for the user control block (XCUSER).

**605**

VERIFY\_BLOCK\_GM\_ERROR

During Initialize\_User processing, a GETMAIN failed for an EXCI internal control block.

**606**

SSI\_VERIFY\_FAILED

A VERIFY call to the MVS subsystem interface (SSI) to obtain the current CICS SVC number failed.

**607**

CICS\_SVC\_CALL\_FAILURE

During Initialize\_User processing, a call to the currently installed CICS SVC failed.

**622**

ESTAE\_SETUP\_FAILURE

In order to protect itself from possible program checks the external CICS interface establishes an MVS ESTAE. In this case, the MVS ESTAE macro has failed.

**623**

ESTAE\_INVOKED

A program check is encountered during call processing, and the ESTAE is invoked.

**627**

INCORRECT\_SVC\_LEVEL

The release level of the CICS SVC (DFHCSVC) is not the same (or higher) than the release level of the external CICS interface.

For more information about response codes, see [“EXCI call response code values” on page 31](#).

For information about the reason codes, see [Response and reason codes returned on EXCI calls](#).

## Allocate\_Pipe

Allocate a single session, or pipe, to a CICS region. This command does not connect the client program to a CICS region; this happens on the **Open\_Pipe** command.

You can allocate up to 250 pipes in an EXCI address space. The default limit is 100 pipes. However, you can increase this using the **LOGONLIM** parameter when you define CICS as an MVS subsystem. See [EXCI pipe allocation in Installing](#).

This limit is set to prevent EXCI clients from monopolizing MRO resources, which could prevent CICS systems from using MRO. The limit is applied in both MRO and cross system MRO (XCF/MRO) environments.

An **ALLOCATE\_PIPE** request results in an MRO LOGON request being issued and there is a limit on the total number of MRO LOGON requests allowed from all address spaces. This is particularly critical when using XCF/MRO, where the limit on the number of members in a XCF group also limits the total number of MRO LOGON requests.

## Syntax

```
CALL DFHXCIS, (version_number, return_area, user_token, call_type,  
              pipe_token, CICS applid, allocate_opts), VL, MF=(E, (1))
```

## Parameters

### **version\_number**

A fullword binary input area indicating the version of the external CICS interface parameter list being used. It must be set to 1 in the client program.

The equated value for this parameter in the CICS-supplied copybook DFHXCPL x (where x indicates the language) is VERSION\_1. See [Table 3 on page 32](#) for copybook details.

### **return\_area**

A 5-word output area to receive response and reason codes, and a message pointer field. For more details, see [“Return area for the EXCI CALL interface” on page 32](#).

### **user\_token**

The 1-word token returned on the **Initialize\_User** command.

### **call\_type**

A 1-word input area indicating the function of the command. It must be set to 2 in the client program to indicate that this is an **Allocate\_Pipe** command.

The equated value for this call in the CICS-supplied copybook DFHXCPL x (where x indicates the language) is ALLOCATE\_PIPE. See [Table 3 on page 32](#) for copybook details.

### **pipe\_token**

A 1-word output area. CICS returns a 32-bit token in this area to represent the allocated session. This token must be used on any subsequent command that uses this session.

### **CICS\_applid (or null\_ptr)**

An 8-byte input area containing the applid of the CICS system to which the allocated session is to be connected.

Although an applid is required to complete the **Allocate\_Pipe** function, this parameter is optional on the **Allocate\_Pipe** call. You can specify the applid either on this parameter to the **Allocate\_Pipe** call, or on the **URMCICS** parameter in the user-replaceable module, DFHXCURM (DFHXCURM is always invoked during **Allocate\_Pipe** processing). You can also use the **URMCICS** parameter in DFHXCURM to override an applid specified on the **Allocate\_Pipe** call. See [The EXCI user-replaceable module](#) for information about the **URMCICS** parameter.

If you omit the applid from the call, you must ensure that the CALL parameter list contains a null address for *CICS\_applid*. How you do this depends on the language you are using for the non-CICS client program. For an example of a call that omits an optional parameter, see [“Example of EXCI CALL with null parameters” on page 33](#).

### **allocate\_opts**

A 1-byte input area to represent options specified on this command. The options specify which type of session is to be used—specific or generic. X'00' represents a specific session. X'80' represents a generic session.

The equated value for these options in the CICS-supplied copybook DFHXCPL x (where x indicates the language) are SPECIFIC\_PIPE and GENERIC\_PIPE. See [Table 3 on page 32](#) for copybook details.

## Responses and reason codes

For all non-zero response codes, a unique reason code value identifies the reason for the response.

**Note:** All numeric response and reason code values are in decimal.

The following is a summary of the response and reason codes that the external CICS interface can return on the **Allocate\_Pipe** call:

### **Response OK**

Command executed successfully (RC 0). Reason code:

**0**

Normal response



### Response **USER\_ERROR**

The command failed because of an error in either the client or the server (RC 12). Reason codes:

**401**

INVALID\_CALL\_TYPE

**402**

INVALID\_VERSION\_NUMBER

**404**

INVALID\_USER\_TOKEN

**421**

RUNNING\_UNDER\_AN\_IRB

### Response **SYSTEM\_ERROR**

The command failed (RC 16). Reason codes:

**604**

XCPPIPE\_GETMAIN\_ERROR

**608**

IRC\_LOGON\_FAILURE

**622**

ESTAE\_SETUP\_FAILURE

**623**

ESTAE\_INVOKED

**628**

IRP\_LEVEL\_CHECK\_FAILURE

For information about response codes, see [“EXCI call response code values” on page 31](#).

For information about the reason codes, see [Response and reason codes returned on EXCI calls](#).

## Open\_Pipe

Cause IRC to connect an allocated pipe to a receive session.

Open\_Pipe causes IRC to connect an allocated pipe to a receive session of the appropriate connection defined in the CICS region named either on the Allocate\_Pipe command, or in DFHXCURM. The appropriate connection is either:

- The EXCI connection with a NETNAME value equal to the *user\_name* parameter on the Initialize\_User command (that is, you are using a specific connection, dedicated to this client program)
- The EXCI connection defined as generic.

In an XCF environment, the Open\_Pipe command causes the interregion communication program, DFHIRP, to connect to the LPAR that receives the request. This request is asynchronous, so although the Open\_Pipe command can receive a good return code, the subsequent DPL\_Request call might fail.

If you shut down CICS without the support of the supplied shutdown-assist transaction (CESD) or an equivalent, and sessions remain open, CICS might not be able to shut its IRC facility in an orderly manner. A normal shutdown of CICS without the support of the shutdown assist transaction waits if any EXCI sessions are not closed. CICS issues message DFHIR2321 indicating the following information:

- The netname of the session if it is on a specific connection
- The word GENERIC if the open sessions are on a generic connection.

If you use the supplied shutdown-assist transaction, CESD, sessions left open do not present a problem to normal shutdown, because CESD issues an immediate close of IRC. Provided that at least one DPL\_Request call has been issued on the session, message DFHIR2321 also shows the job name, step name, and procedure name of the client job that is using the session, and the MVS ID of the MVS image on which the client program is running.

## Syntax

```
CALL DFHXCIS, (version_number, return_area, user_token, call_type,  
              pipe_token), VL, MF=(E, (1))
```

## Parameters

### **version\_number**

A fullword binary input area indicating the version of the external CICS interface parameter list being used. It must be set to 1 in the client program.

The equated value for this parameter in the CICS-supplied copybook DFHXCPL x (where x indicates the language) is VERSION\_1. See topic [Table 3 on page 32](#) for copybook details.

### **return\_area**

A 5-word output area to receive response and reason codes, and a message pointer field. For more details, see [“Return area for the EXCI CALL interface” on page 32](#).

### **user\_token**

The 1-word token returned on the Initialize\_User command.

### **call\_type**

A 1-word input area indicating the function of the command. This must be set to 3 in the client program to indicate that this is an Open\_pipe command.

The equated value for this call in the CICS-supplied copybook DFHXCPL x (where x indicates the language) is OPEN\_PIPE. See topic [Table 3 on page 32](#) for copybook details.

### **pipe\_token**

A 1-word output area containing the token passed by CICS on the Allocate\_Pipe command. It represents the pipe being opened on this command.

## Responses and reason codes

For all non-zero response codes, a unique reason code value identifies the reason for the response.

**Note:** All numeric response and reason code values are in decimal.

The following is a summary of the response and reason codes that the external CICS interface can return on the Open\_Pipe call:

### **Response OK**

Command executed successfully (RC 0). Reason code:

**0**

NORMAL

### **Response WARNING**

The command executed successfully, but with an error (RC 4). Reason codes:

**1**

PIPE\_ALREADY\_OPEN

### **Response RETRYABLE**

The command failed because of setup errors but can be reissued (RC 8). Reason codes:

**202**

NO\_PIPE

**203**

NO\_CICS

### **Response USER\_ERROR**

The command failed because of an error in either the client or the server (RC 12). Reason codes:

- 401**  
INVALID\_CALL\_TYPE
- 402**  
INVALID\_VERSION\_NUMBER
- 404**  
INVALID\_USER\_TOKEN
- 418**  
INVALID\_PIPE\_TOKEN
- 421**  
RUNNING\_UNDER\_AN\_IRB

**Response SYSTEM\_ERROR**

The command failed (RC 16). Reason codes:

- 608**  
IRC\_LOGON\_FAILURE
- 609**  
IRC\_CONNECT\_FAILURE
- 621**  
PIPE\_RECOVERY\_FAILURE
- 622**  
ESTAE\_SETUP\_FAILURE
- 623**  
ESTAE\_INVOKED

For information about response codes, see [“EXCI call response code values”](#) on page 31.

For information about the reason codes, see [Response and reason codes returned on EXCI calls](#).

**DPL\_Request**

Issue a distributed program link request across an open pipe connected to the CICS system on which the server (or target) application program resides.

The command is synchronous, and the TCB waits for a response from CICS. After a pipe is opened, any number of DPL requests can be issued before the pipe is closed. To the server program, the link request appears just like a standard **EXEC CICS LINK** request from another CICS region, and it is not aware that it is sent from a non-CICS client program using EXCI.

The syntax of the call is shown in three forms: the parameters that can be used when *version\_number* is set to VERSION\_1, the parameters that can be used when *version\_number* is set to VERSION\_2, and the parameters that can be used when *version\_number* is set to VERSION\_3.

**Syntax**

**VERSION\_1**

```
CALL DFHXCIS, (version_number, return_area, user_token, call_type,
              pipe_token, pgmname, COMMAREA, COMMAREA_len, data_len,
              transid, uowid, userid, dpl_retarea, DPL_opts), VL, MF=(E, (1))
```

**VERSION\_2**

```
CALL DFHXCIS, (version_number, return_area, user_token, call_type,
              pipe_token, pgmname, COMMAREA, COMMAREA_len, data_len,
              transid, uowid, userid, dpl_retarea, DPL_opts,
              transid2, ccsid, endian), VL, MF=(E, (1))
```

## VERSION\_3

```
CALL DFHXCIS, (version_number, return_area, user_token, call_type,  
             pipe_token, pgmname, CHANNEL, 0, 0,  
             transid, uowid, userid, dpl_retarea, DPL_opts,  
             transid2, 0, 0), VL, MF=(E, (1))
```

### Parameters

#### **version\_number**

A fullword binary input area that indicates the version of the external CICS interface parameter list being used. This can be set to 1, 2, or 3 in the client program.

The equated value for this parameter in the CICS-supplied copybook DFHXCPL *x* (where *x* indicates the language) is either VERSION\_1, VERSION\_2, or VERSION\_3. See [“Return area and function call EQUATE copybooks”](#) on page 32 for copybook details.

#### **return\_area**

A 5-word output area to receive response and reason codes, and a message pointer field. For more details, see [“Return area for the EXCI CALL interface”](#) on page 32.

#### **user\_token**

A 1-word input area that specifies the user token returned to the client program on the **Initialize\_User** command.

#### **call\_type**

A 1-word input area that indicates the function of the command. This must be set to 6 in the client program to indicate that the pipe is now being used for the DPL\_Request call.

The equated value for this call in the CICS-supplied copybook DFHXCPL *x* (where *x* indicates the language) is DPL\_REQUEST. See [“Return area and function call EQUATE copybooks”](#) on page 32 for copybook details.

#### **pipe\_token**

A 1-word input area that specifies the token returned by EXCI on the **Allocate\_Pipe** command. It represents the pipe being used for the **DPL\_Request** call.

#### **pgmname**

The 8-character name of the CICS application program being called as the server program.

This is either the name as specified on a predefined PROGRAM resource definition installed in the CICS server region, or as it is known to a user-written autoinstall program if the program is to be autoinstalled. The program can be defined in the CICS server region as a local program, or it can be defined as remote. Programs defined as remote enable *daisy-chaining*, where EXCI-CICS DPL calls become EXCI-CICS-CICS DPL calls.

#### **COMMAREA (or null\_ptr)**

A variable length input area for the communications area (COMMAREA) between the client and server programs. The length is defined by *COMMAREA\_len*.

This is the storage area that contains the data to be sent to the CICS application program. This area is also used to receive the updated COMMAREA from the CICS application program (the server program).

This parameter is optional. If it is not required, you must ensure that the CALL parameter list contains a null address for this parameter. How you do this depends on the language you are using for the non-CICS client program. For an example of a call that omits an optional parameter, see [“Example of EXCI CALL with null parameters”](#) on page 33.

#### **COMMAREA\_len**

A fullword binary input area. This parameter specifies the length of the COMMAREA. It is also the length of the server program's COMMAREA (EIBCALEN).

If you specify a COMMAREA, you must also specify this parameter to define the length.

This value should not exceed 24 KB if the COMMAREA is to be passed between any two CICS servers (for any combination of product/version/release). Otherwise, if you are confident that the COMMAREA will not be passed on a further LINK request, you can use a COMMAREA up to 32 KB in length.

If you do not specify a COMMAREA, this parameter is ignored.

### ***data\_len***

A fullword binary input area. This parameter specifies the length of contiguous storage, from the start of the COMMAREA, to be sent to the server program.

This parameter restricts the amount of data sent to the server program, and should be used to optimize performance if, for example, the COMMAREA is large but the amount of data being passed is small.

On return from the server program, the EXCI data transformer program ensures that the COMMAREA in the non-CICS client program is the same as that of the server program. This caters for the following conditions:

- The data returned is more than the data passed in the original COMMAREA.
- The data returned is less than the data passed in the original COMMAREA.
- There is no data returned because it is unchanged.
- The server is returning null data.

The value of *data\_len* must not be greater than the value of *COMMAREA\_len*. A value of zero is valid and results in no data being sent to the server program.

If you do not specify a COMMAREA, this parameter is ignored.

### **CHANNEL**

A 16-character input area that contains the name of a channel that is to be made available to the called program. The acceptable characters are A - Z a - z 0 - 9 \$ @ # / % & ? ! : | " = ~ , ; < > . - and \_ . Leading and embedded blank characters are not permitted. If the name supplied is less than 16 characters, it is padded with trailing blanks up to 16 characters. If the channel does not exist, it is created. As there is only one LINK level for an EXCI client, this channel remains in scope. For more information about channel scope, see [The scope of a channel](#).

Channel names are always in EBCDIC. The set of allowed characters for channel names, as listed earlier, includes some characters that do not have the same representation in all EBCDIC code pages. Therefore, if channels are to be shipped between regions, it is advisable to restrict the characters that are used to name channels to A-Z a-z 0-9 & : = , ; < > . - and \_ .

You can specify the channel name DFHTRANSACTION to use a transaction channel. In CICS, a transaction channel does not go out of scope when the link level changes: it is always accessible in the transaction. For more information, see [Channels and containers](#).

The program that issues the **DPL\_REQUEST** command can specify the name of a channel on the command. The specified channel might already exist, created by the program using one or more **PUT CONTAINER** commands. Alternatively, the program can specify the name of a channel that does not currently exist, in which case a new empty channel is created.

**Note:** The two parameters following CHANNEL must be null. In addition, the **ccsid** and **endian** parameters must be null.

### ***transid (or null\_ptr)***

A 4-character input area that contains the id of the CICS mirror transaction under which the server program is to run. This transaction must be defined to the CICS server region, and its definition must specify:

#### **PROGRAM(DFHMIRS)**

The initial program must be the CICS supplied mirror program DFHMIRS.

Failure to specify DFHMIRS as the initial program means that a COMMAREA passed from the client application program is not passed to the CICS server program. Also, the DPL request

fails and the client application program receives a response of SYSTEM\_ERROR and reason SERVER\_PROTOCOL\_ERROR.

### **PROFILE(DFHICSA)**

The DFHICSA profile specifies the correct value for the INBFMH parameter, which must be specified as INBFMH(ALL) for a mirror transaction.

When the CICS server region receives a DPL request, it attaches the mirror transaction and invokes DFHMIRS. The mirror program then passes control to the requested server program, passing the COMMAREA supplied by the client program. The COMMAREA passed to the server program is primed with the data only, the remainder of the COMMAREA being set to nulls.

The purpose of the transid parameter is to distinguish between different invocations of the server program. This enables you to run different invocations of the server program under transactions that specify different attributes. For example, you can vary the transaction priorities, or the security requirements.

A transid is optional. By default, the CICS server region uses the CICS-supplied mirror transaction, CSMI. If you do not want to specify *transid*, you must ensure that the CALL parameter list contains a null address for this parameter. How you do this depends on the language you are using for the non-CICS client program. For an example of a call that omits an optional parameter, see [“Example of EXCI CALL with null parameters”](#) on page 33.

If you issue multiple requests in the same MVS unit-of-recovery, the same transid must be used in all of them.

### ***uowid* (or null\_ptr)**

An input area that contains a unit-of-work identifier, using the APPC architected format, that is passed on the DPL\_Request for correlation purposes.

For DPL requests that are committed when the CICS program returns control to the MVS application, this parameter is optional.

For DPL requests that are part of an RRMS unit-of-recovery, *null\_ptr* must be specified. The unit-of-work identifier that is already associated with the RRMS unit-of-recovery is used, if there is one; if not, CICS (or another RRMS resource manager) generates a unique unit-of-work identifier and associates it with the RRMS unit-of-recovery.

If you do not want to specify a *uowid* parameter, you must ensure that the CALL parameter list contains a null address for this parameter. How you do this depends on the language you are using for the non-CICS client program. For an example of a call that omits an optional parameter, see [“Example of EXCI CALL with null parameters”](#) on page 33.

The *uowid* parameter is passed to the CICS server region, which uses it as the UOWID for the first unit of work executed by the CICS server program. If the server program issues intermediate sync points before returning to the client program, CICS uses the supplied *uowid* for the subsequent units of work, but with the two-byte sequence number incremented for each new logical unit of work. If the CICS server program updates remote resources, the client-supplied UOWID is distributed to the remote systems that own the resources.

The *uowid* parameter is supplied on the EXCI CALL interface for correlation purposes only, to allow units of work that originated from a particular client program to be identified in CICS. The *uowid* is not provided for recovery purposes between CICS and the client program.

The *uowid* can be a maximum of 27 bytes long and has the following format:

- A 1-byte length field that contains the overall length of the UOWID (excluding this field).
- A 1-byte length field that contains the length of the logical unit name (excluding this field).
- A logical unit name field of variable length up to a maximum of 17 bytes.

To conform to APPC architecture rules, the LUNAME must be of the form `AAAAAAAA.BBBBBBBB`, where `AAAAAAAA` is optional and:

- `AAAAAAAA` and `BBBBBBBB` are 8-byte names separated by a period

- If AAAAAAAAA is omitted, the period must also be omitted
- AAAAAAAAA and BBBBBBBB must be type-1134 symbol strings (that is, character strings consisting of one or more EBCDIC uppercase letters A - Z and 0 - 9, the first character of which must be an uppercase letter).
- The clock value; the middle 6 bytes of an 8-byte store clock (STCK) value.
- A 2-byte sequence number.

If you omit a unit-of-work identifier (by specifying a null pointer), and the DPL request is not part of an RRMS unit-of-recovery, the external CICS interface generates one for you, consisting of the following:

- A 1-byte length field set to X'1A'.
- A 1-byte LU length field set to X'11'.
- A 17-byte LU name consisting of:
  - An 8-byte eyecatcher set to DFHEXCIU.
  - A 1-byte field that contains a period (.)
  - A 4-byte field that contains the MVS system identifier (SYSID), in characters, under which the client is running.
  - A 4-byte field that contains the address space id (ASID) in which the MVS client program is running. The field contains the four character EBCDIC representation of the 2-byte hex address space id.
- The clock value; the middle 6 bytes of an 8-byte store clock (STCK) value
- A 2-byte sequence number set to X'0001'.

#### **userid (or null\_ptr)**

An 8-character input area that contains the RACF® userid for user security checking in the CICS region. The external CICS interface passes this userid to the CICS server region for user resource and command security checking in the server application program.

A userid is required only if the MRO connection specifies the ATTACHSEC(IDENTIFY) attribute. If the connection specifies ATTACHSEC(LOCAL), the CICS server region applies link security checking. See [Intercommunication security](#) for information about link security on MRO connections.

See also [EXCI security](#) for information about external CICS interface security considerations.

This parameter is optional. However, if you do not specify a userid, the external CICS interface passes the security userid under which the client program is running. For example, if the client program is running as an MVS batch job, the external CICS interface obtains and passes the userid specified on the USER parameter of the JOB statement.

If you specify a userid, the userid under which the EXCI job is running is subject to a surrogate user check. This check is performed by the external CICS interface to ensure that the client job userid is authorized to use the userid specified on the DPL call. For more information about surrogate user security checking, see [EXCI security](#).

If you want to let *userid* default, you must ensure that the CALL parameter list contains a null address for this parameter. How you do this depends on the language you are using for the non-CICS client program. For an example of a call that omits an optional parameter, see [“Example of EXCI CALL with null parameters”](#) on page 33.

If you issue multiple requests in the same MVS unit-of-recovery, the same userid must be used in all of them. If the unit-of-recovery also includes EXEC CICS calls, you should allow the userid on all DPL\_requests to default to the security userid under which the client program is running.

#### **dpl\_retarea**

A 12-byte output area into which the DPL\_Request processor places responses to the DPL request. Generally, these responses are from CICS, but in some cases the error detection occurs in the external CICS interface, which returns exception conditions that are the equivalent of those returned by an **EXEC CICS LINK** command.

This field is only meaningful in the following circumstances:

- The response field of the EXCI return-area has a zero value
- The EXCI return-area indicates that the server program has abended (response=USER\_ERROR and reason=SERVER\_ABENDED).

The 12 bytes form three fields, providing the following information:

**Field 1 ( fullword value )**

This field is a fullword that contains a RESP value from the DPL\_Request call. See [“Error codes” on page 37](#) for the RESP values that can be returned on a DPL\_Request call.

If the DPL\_Request call reaches CICS , this field contains the EIBRESP value, otherwise it contains an equivalent response set by the external CICS interface. If this field is set by the external CICS interface, RESP is further qualified by a RESP2 value in the second field.

A zero value is the normal response, which equates to EXEC\_NORMAL in the return codes copybooks.

**Field 2 ( fullword value )**

This field is a fullword that can contain a RESP2 value from the link request, further qualifying the RESP value in field 1.

If the DPL\_Request call reaches CICS , the RESP2 field generally is null ( CICS does not return RESP2 values across MRO links). However, if the RESP field indicates SYSIDERR (value 53), this field provides a reason code. See [“Dpl\\_retarea return codes” on page 33](#) for more information.

If the RESP field is set by the external CICS interface, it is further qualified by a RESP2 value in this second field. For example, if the *data\_len* parameter specifies a value greater than the *COMMAREA\_len* parameter, the external CICS interface returns the RESP value 22 (which equates to EXEC LENGERR in the return codes copybooks), and a RESP2 value of 13.

See the LINK conditions in [LINK](#) for full details of the possible RESP and RESP2 values.

**Note:** The data transformer program makes special use of the RESP2 field. If any error occurs in the transformer, the error is returned in RESP2.

**Field 3 ( fullword value )**

The third field, a 4-character field, contains the following information:

- The abend code if the server program abended
- Four blanks if the server program did not abend.

If a server program abends, it is backed out to its last syncpoint, which can be the start of the task, or an intermediate syncpoint. The server program can issue intermediate syncpoints because SYNCONRETURN is forced.

**DPL\_opts (or null\_ptr)**

A 1-byte input area that indicates options to be used on the DPL\_Request call.

If you omit this parameter, it defaults to the value X'00'. If you want to omit *DPL\_opts* and let it default, ensure that the CALL parameter list contains a null address for this parameter. How you do this depends on the language you are using for the non-CICS program. For an example of a call that omits an optional parameter, see [“Example of EXCI CALL with null parameters” on page 33](#).

Currently, the *DPL\_opts* parameter applies only to resource recovery, using the following values:

**X'00'**

Indicates that you specified NOSYNCONRETURN, because you want the client batch program to control resource recovery, using 2-phase commit protocols supported by MVS RRS. With this option, the CICS server region does not perform a syncpoint when the server program returns control to CICS . Furthermore, the CICS server application program must not take any explicit syncpoints, otherwise it is abended by CICS . For more information, see [“Resource recovery” on page 8](#).



## X'80'

Indicates that SYNCONRETURN is required in the CICS server region.

SYNCONRETURN specifies that the server region is to take a syncpoint on successful completion of the server program, independently of the client program. This option does not prevent a server program from taking its own explicit syncpoints.

The equated value for this parameter in the CICS-supplied copybook DFHXCPL x (where x indicates the language) is SYNCONRETURN. See [“Return area and function call EQUATE copybooks”](#) on page 32 for copybook details.

### **transid2 (or null\_ptr) Applicable to VERSION\_2 or later**

A 4-character input area that contains a CICS transaction id.

The server program runs under a CICS -supplied mirror transaction, CSMI or CPMI. However the transaction id made available to the server program through the EIBTRNID field in the Exec Interface Block is the one specified by the **transid2** parameter. The **transid2** parameter is ignored if the **transid** parameter is specified. The following table gives an example of different combinations of **transid** and **transid2** :

<b>transid</b>	<b>transid2</b>	<b>program executes under</b>	<b>EIBTRNID seen by program</b>
UTRN	omitted	UTRN	UTRN
UTRN	UEIB	UTRN	UTRN
omitted	omitted	CSMI	CSMI
omitted	UEIB	CSMI	UEIB

The **transid2** parameter is useful for server programs that access Db2®, because EIBTRNID is used to determine which DB2ENTRY definition to use. Previously, EIBTRNID could only be set by using **transid**, which then required you to define a mirror transaction to CICS. Using **transid2**, EIBTRNID is set, but the mirror program executes under the CICS provided definition CSMI.

### **ccsid (or null\_ptr) VERSION\_2 only**

A fullword binary input area that indicates the Coded Character Set Identifier (CCSID) of the character data contained in the COMMAREA. The ccsid parameter must be specified if character data has to be converted when the COMMAREA is passed to, or returned from, the server program. The parameter can take the following values:

#### **-1 (X'FFFFFFFF')**

Indicates that conversion of character data is required and that the source CCSID is defined in the conversion template installed in the server.

#### **1 <= ccsid <= 65535**

Indicates that conversion of character data is required and that the value specified overrides the source CCSID defined in the conversion template installed in the server.

### **endian (or null\_ptr) VERSION\_2 only**

A fullword binary input area that indicates the format, big endian or little endian, for binary data contained in the COMMAREA. Big endian indicates that the leftmost byte contains the most significant digits, as used, for example, in System 390 architecture. Little endian indicates that the rightmost byte contains the most significant digits, as used, for example, in Intel architecture. The endian parameter should be specified if binary data has to be converted when the COMMAREA is passed to, or returned from, the server program. If the ccsid parameter indicates that conversion is required, but endian is not specified (defaults to null), conversion of binary data depends on what is specified in the DFHCNV conversion template installed in the server. The parameter can take the following values:

#### **16909060 (X'01020304')**

Binary data is held in big endian format.

## 67305985 (X'04030201')

Binary data is held in little endian format.

### Responses and reason codes

For all non-zero response codes, a unique reason code value identifies the reason for the response.

**Note:** All numeric response and reason code values are in decimal.

The following is a summary of the response and reason codes that the external CICS interface can return on the DPL call:

#### Response OK

Command executed successfully (RC 0). Reason code:

**0**

NORMAL

#### Response WARNING

The command executed successfully, but with an error (RC 4). Reason codes:

**6**

IRP\_IOAREA\_FM\_FAILURE

**7**

SERVER\_TERMINATED

#### Response RETRYABLE

The command failed because of setup errors but can be reissued (RC 8). Reason codes:

**203**

NO\_CICS

**204**

WRONG\_MVS\_FOR\_RRMS

**205**

RRMS\_NOT\_AVAILABLE

#### Response USER\_ERROR

The command failed because of an error in either the client or the server (RC 12). Reason codes:

**401**

INVALID\_CALL\_TYPE

**402**

INVALID\_VERSION\_NUMBER

**404**

INVALID\_USER\_TOKEN

**406**

PIPE\_NOT\_OPEN

**407**

INVALID\_USERID

**408**

INVALID\_UOWID

**409**

INVALID\_TRANSID

**414**

IRP\_ABORT\_RECEIVED

**415**

INVALID\_CONNECTION\_DEFN

- 416**  
INVALID\_CICS\_RELEASE
- 417**  
PIPE\_MUST\_CLOSE
- 418**  
INVALID\_PIPE\_TOKEN
- 421**  
RUNNING\_UNDER\_AN\_IRB
- 422**  
SERVER\_ABENDED
- 423**  
SURROGATE\_CHECK\_FAILED
- 425**  
UOWID\_NOT\_ALLOWED
- 426**  
INVALID\_TRANSID2
- 427**  
INVALID\_CCSID
- 428**  
INVALID\_ENDIAN
- 431**  
COMMAREA\_LEN\_NOT\_ALLOWED
- 432**  
DATA\_LEN\_NOT\_ALLOWED
- 433**  
CCSID\_NOT\_ALLOWED
- 434**  
ENDIAN\_NOT\_ALLOWED

**Response SYSTEM\_ERROR**

The command failed (RC 16). Reason codes:

- 612**  
TRANSFORM\_1\_ERROR
- 613**  
TRANSFORM\_4\_ERROR
- 614**  
IRP\_NULL\_DATA\_RECEIVED
- 615**  
IRP\_NEGATIVE\_RESPONSE
- 616**  
IRP\_SWITCH\_PULL\_FAILURE
- 617**  
IRP\_IOAREA\_GM\_FAILURE
- 619**  
IRP\_BAD\_IOAREA
- 620**  
IRP\_PROTOCOL\_ERROR
- 622**  
ESTAE\_SETUP\_FAILURE

- 623**  
ESTAE\_INVOKED
- 624**  
SERVER\_TIMEDOUT
- 625**  
STIMER\_SETUP\_FAILURE
- 626**  
STIMER\_CANCEL\_FAILURE
- 629**  
SERVER\_PROTOCOL\_ERROR
- 630**  
RRMS\_ERROR
- 631**  
RRMS\_SEVERE\_ERROR
- 632**  
XCGUR\_GETMAIN\_ERROR

## Close\_PIPE

Disconnect an open pipe from CICS. The pipe remains in an allocated state, and its tokens remain valid for use by the same user. To reuse a closed pipe, the client program must first reissue an Open\_Pipe command using the pipe token returned on the Allocate\_Pipe command for the pipe.

Pipes should be closed when not in use because this prevents CICS from shutting down its IRC facility in an orderly manner. Therefore, the Close\_Pipe command should be issued as soon as possible after all DPL\_Request calls have completed.

## Syntax

```
CALL DFHXCIS,(version_number,return_area,user_token,call_type,
             pipe_token),VL,MF=(E,(1))
```

## Parameters

### ***version\_number***

A fullword binary input area indicating the version of the external CICS interface parameter list being used. It must be set to 1 in the client program.

The equated value for this parameter in the CICS-supplied copybook DFHXCPL x (where x indicates the language) is VERSION\_1. See [“Deallocate\\_Pipe” on page 29](#) for copybook details.

### ***return\_area***

A 5-word output area to receive response and reason codes, and a message pointer field. For more details, see [“Return area for the EXCI CALL interface” on page 32](#).

### ***user\_token***

The 1-word input area specifying the token, returned to the client program by EXCI on the Initialize\_User command, that represents the user of the pipe being closed.

### ***call\_type***

A 1-word input area indicating the function of the command. This must be set to 4 in the client program to indicate that this is a Close\_Pipe command.

The equated value for this call in the CICS-supplied copybook DFHXCPL x (where x indicates the language) is CLOSE\_PIPE. See [“Return area and function call EQUATE copybooks” on page 32](#) for copybook details.

### ***pipe\_token***

A 1-word input area specifying the token, returned to the client program by EXCI on the original Allocate\_Pipe command, that represents the pipe being closed.

## **Responses and reason codes**

For all non-zero response codes, a unique reason code value identifies the reason for the response.

**Note:** All numeric response and reason code values are in decimal.

The following is a summary of the response and reason codes that the external CICS interface can return on the Close\_Pipe call:

### **Response OK**

Command executed successfully (RC 0). Reason code:

**0**  
NORMAL

### **Response WARNING**

The command executed successfully, but with an error (RC 4). Reason codes:

**2**  
PIPE\_ALREADY\_CLOSED

### **Response USER\_ERROR**

The command failed because of an error in either the client or the server (RC 12). Reason codes:

**401**  
INVALID\_CALL\_TYPE  
**402**  
INVALID\_VERSION\_NUMBER  
**404**  
INVALID\_USER\_TOKEN  
**418**  
INVALID\_PIPE\_TOKEN  
**421**  
RUNNING\_UNDER\_AN\_IRB

### **Response SYSTEM\_ERROR**

The command failed (RC 16). Reason codes:

**610**  
IRC\_DISCONNECT\_FAILURE  
**622**  
ESTAE\_SETUP\_FAILURE  
**623**  
ESTAE\_INVOKED

For information about response codes, see [“EXCI call response code values”](#) on page 31.

For information about the reason codes, see [Response and reason codes returned on EXCI calls](#).

## **Deallocate\_Pipe**

Deallocate a pipe from CICS. On completion of this command, the pipe can no longer be used, and its associated tokens are invalid. This command should be issued for pipes that are no longer required. This command frees storage associated with the pipe.

**Note:** After a successful **Open\_Pipe** request, when your client program finishes using the pipe, you must first issue a **Close\_Pipe** command and then a **Deallocate\_Pipe** command to free the pipe. If you

issue a **Deallocate\_Pipe** command without first closing an open pipe with **Close\_Pipe**, your request fails.

## Syntax

```
CALL DFHCIS,(version_number,return_area,user_token,call_type,  
            pipe_token),VL,MF=(E,(1))
```

## Parameters

### ***version\_number***

A fullword binary input area indicating the version of the external CICS interface parameter list being used. It must be set to 1 in the client program.

The equated value for this parameter in the CICS-supplied copybook DFHCPL x (where x indicates the language) is VERSION\_1. See [“Return area and function call EQUATE copybooks” on page 32](#) for copybook details.

### ***return\_area***

A 5-word output area to receive response and reason codes, and a message pointer field. For more details, see [“Return area for the EXCI CALL interface” on page 32](#).

### ***user\_token***

A 1-word input area containing the token returned on the Initialize\_User command.

### ***call\_type***

A 1-word input area indicating the function of the command. This must be set to 5 in the client program to indicate that this is a Deallocate\_Pipe command.

The equated value for this call in the CICS-supplied copybook DFHCPL x (where x indicates the language) is DEALLOCATE\_PIPE. See [“Return area and function call EQUATE copybooks” on page 32](#) for copybook details.

### ***pipe\_token***

A 1-word input area containing the token passed back on the original Allocate\_Pipe command, that represents the pipe now being deallocated.

## Responses and reason codes

For all non-zero response codes, a unique reason code value identifies the reason for the response.

**Note:** All numeric response and reason code values are in decimal.

The following is a summary of the response and reason codes that the external CICS interface can return on the Deallocate\_Pipe call:

### **Response OK**

Command executed successfully (RC 0). Reason code:

**0**  
NORMAL

### **Response WARNING**

The command succeeded successfully, but with an error (RC 4). Reason codes:

**5**  
XCPIPE\_FREEMAIN\_ERROR

**6**  
IRP\_IOAREA\_FM\_FAILURE

### **Response USER\_ERROR**

The command failed because of an error in either the client or the server (RC 12). Reason codes:

- 401**  
INVALID\_CALL\_TYPE
- 402**  
INVALID\_VERSION\_NUMBER
- 404**  
INVALID\_USER\_TOKEN
- 405**  
PIPE\_NOT\_CLOSED
- 418**  
INVALID\_PIPE\_TOKEN
- 421**  
RUNNING\_UNDER\_AN\_IRB

**Response SYSTEM\_ERROR**

The command failed (RC 16). Reason codes:

- 611**  
IRC\_LOGOFF\_FAILURE
- 622**  
ESTAE\_SETUP\_FAILURE
- 623**  
ESTAE\_INVOKED

For information about response codes, see [“EXCI call response code values”](#) on page 31.

For information about the reason codes, see [Response and reason codes returned on EXCI calls.](#)

## EXCI call response code values

This table shows the values that can be returned in the response field. All values are in decimal.

*Table 2. EXCI response codes (returned in response field of return\_area)*

Code	Meaning	Explanation
0	OK	For all EXCI CALL commands other than the DPL_request, the call was successful. If an OK response is received for a DPL_request, you must also check <i>dpl_retarea</i> to ensure CICS did not return a condition code. If the EIBRESP field of <i>Dpl_retarea</i> is zero, the DPL call was successful.
4	WARNING	The external CICS interface detected an error, but this did not stop the CALL command completing successfully. The reason code field describes the error detected.
8	RETRYABLE	The EXCI CALL command failed. This class of failure relates to errors in the setup of the system environment, and not errors in the external CICS interface or client program. The reason code documents the specific error in the environment setup.  The external CICS interface command can be reissued without changing the client program once the environment error has been corrected. The environmental errors concerned are ones that do not require an MVS re-IPL. Each reason code value for a RETRYABLE response documents whether the CALL can be reissued directly, or whether the pipe being used has to be closed and reopened first.

Table 2. EXCI response codes (returned in response field of *return\_area*) (continued)

Code	Meaning	Explanation
12	USER_ERROR	The EXCI CALL command failed. This class of error means there is an error either in the client program, or in the CICS server program, or in the CICS server region. An example of an error in the CICS server system would be a failed security check, or an abend of the CICS server program, in which case the abend code is set in the abend code field of <i>dpl_retarea</i> . Each reason code value for a response of USER_ERROR explains whether the command can be reissued directly, or whether the pipe being used has to be closed and reopened first.
16	SYSTEM_ERROR	The EXCI CALL command failed. This class of error means that the external CICS interface has detected an error. The reason code value identifies the specific error. If the error can be corrected, then the command can be reissued. Each reason code value for a SYSTEM_ERROR response explains whether the command can be reissued directly, or whether the pipe being used has to be closed and reopened first.

## Return area for the EXCI CALL interface

This is the format of the 5-word return area for the EXCI CALL interface.

1. 1-word response field.
2. 1-word reason field.
3. Two 1-word subreason fields—subreason field-1 and subreason field-2.
4. 1-word CICS message pointer field. This is zero if there is no message present. If a message is present, this field contains the address of the storage area containing the message, which is formatted as follows:
  - A 2-byte LL field. LL is the length of the message plus the length of the LLBB field.
  - A 2-byte BB field, set to binary zero.
  - A variable length field containing the text of the message.

## Return area and function call EQUATE copybooks

CICS provides four language-specific copybooks that map the storage areas for the *return\_area* and *dpl\_retarea* parameters of the EXCI CALL commands. The copybooks also provide EQUATE statements for each type of EXCI CALL.

These copybooks, and the libraries they are supplied in for the supported languages, are shown in [Table 3](#) on page 32.

Copybook name	Language	Library
DFHXCPLD	Assembler	CICSTS55 .CICS.SDFHMAC
DFHXCPLH	C	CICSTS55 .CICS.SDFHC370
DFHXCPLD	COBOL	CICSTS55 .CICS.SDFHCOB
DFHXCPLL	PL/I	CICSTS55 .CICS.SDFHPL1



## Return codes

All the possible return codes are contained in a CICS-supplied copybook, which you must include in the program source of your external, non-CICS program.

The names of the copybooks for the supported languages, and the libraries that they are supplied in, are shown in [Table 4 on page 33](#).

Copybook name	Language	Library
DFHXCRCD	Assembler	CICSTS55 .CICS.SDFHMAC
DFHXCRCH	C	CICSTS55 .CICS.SDFHC370
DFHXCRCO	COBOL	CICSTS55 .CICS.SDFHCOB
DFHXCRCL	PL/I	CICSTS55 .CICS.SDFHPL1

z/OS provides copybooks for use with the interfaces described in [“Use of sync points in the client program” on page 11](#). These are described in [z/OS MVS Programming: Resource Recovery](#) and [z/OS MVS Programming: Callable Services for High-Level Languages](#).

## Dpl\_retarea return codes

These are the same as for CICS-to-CICS EXEC CICS DPL commands but with the following additions for the EXCI call interface.

Table 5. Exceptional conditions. RESP and RESP2 values returned to dpl\_retarea

Condition	RESP2	Meaning
LENGERR	22	COMMAREA_LEN_TOO_BIG
LENGERR	23	COMMAREA_BUT_NO_COMMAREA_LEN

SYSIDERR also can be returned on an EXCI DPL\_Request, if the DPL\_Request specifies a program defined in the CICS server region as a remote program, and the link between the server and the remote CICS region is not open. In this situation, SYSIDERR is returned in the first word of the DPL\_Retarea (code 53). The reason code qualifying SYSIDERR is placed in the second word of this area (the equivalent of a RESP2 value). For SYSIDERR, the information stored in this field is derived from bytes 1 and 2 of the CICS EIBRCODE field. For example, if a remote link is not available, the EIBRCODE value stored in bytes 2 and 3 of the DPL\_Retarea RESP2 field is X'0800'. For a list of the SYSIDERR reason codes that can be returned in the RESP2 field, see the SYSIDERR section of the notes on EIBRCODE in [Attention identifier constants, DFHAID](#).

TERMERR also may be returned on an EXCI DPL request if the DPL request was to a program defined as remote, and an unrecoverable error occurs during conversation with the mirror on the remote CICS system. For example, suppose client program BATCH1 issues an EXCI DPL request to CICSA for program PROG1, which is defined as remote, and the request is function-shipped to CICSB where the program resides. If the session between CICSA and CICSB fails, or CICSB itself fails while executing the program PROG1, then TERMERR is returned to CICSA, and in turn to BATCH1.

No unique EXCI\_DPL\_RESP2 values are returned for TERMERR, PGMIDERR, NOTAUTH, and ROLLBACK.

## Example of EXCI CALL with null parameters

If you omit an optional parameter, such as *userid* on a DPL\_Request, you must ensure that the parameter list is built with a null address for the missing parameter.

The example that follows illustrates how to issue an EXCI DPL\_Request with the *userid* and *uowid* parameters omitted in a COBOL program.

**DPL CALL without userid and uowid (COBOL):** In this example, the DPL parameters used on the call are defined in the WORKING-STORAGE SECTION, as follows:

DPL parameter	COBOL variable	Field definition
<i>version_number</i>	01 VERSION-1	PIC S9(8) COMP VALUE 1.
<i>return_area</i>	01 EXCI-RETURN-CODE.	(structure)
<i>user_token</i>	01 USER-TOKEN	PIC S9(8) COMP VALUE ZERO.
<i>call_type</i>	03 DPL-REQUEST	PIC S9(8) COMP VALUE 6.
<i>pipe_token</i>	01 PIPE-TOKEN	PIC S9(8) COMP VALUE ZERO.
<i>pgmname</i>	01 TARGET-PROGRAM	PIC X(8) VALUE "DFHœAXCS".
<i>commarea</i>	01 COMMAREA.	(structure)
<i>commarea_len</i>	01 COMM-LENGTH	PIC S9(8) COMP VALUE 98.
<i>data_len</i>	01 DATA-LENGTH	PIC S9(8) COMP VALUE 18.
<i>transid</i>	01 TARGET-TRANSID	PIC X(4) VALUE "EXCI".
<i>dpl_retarea</i>	01 EXCI-DPL-RETAREA.	(structure)
<i>dpl_opts</i>	01 SYNCONRETURN	PIC X VALUE X'80'.

The variable used for the null address is defined in the LINKAGE SECTION:

```
LINKAGE SECTION.
    01 NULL-PTR USAGE IS POINTER.
```

Using the data names specified in the WORKING-STORAGE SECTION, and the NULL-PTR name as described in the LINKAGE SECTION, the following invocation of the DPL function omits the *uowid* and the *userid* parameters, and replaces them in the parameter list with the NULL-PTR variable:

```
DPL-SECTION.
*
* SET ADDRESS OF NULL-PTR TO NULLS.
*
CALL 'DFHXCIS' USING VERSION-1 EXCI-RETURN-CODE USER-TOKEN
DPL-REQUEST PIPE-TOKEN TARGET-PROGRAM
COMMAREA COMM-LENGTH DATA-LENGTH
TARGET-TRANSID NULL-PTR NULL-PTR
EXCI-DPL-RETAREA SYNCONRETURN.
```

This example is taken from the CICS-supplied sample external CICS interface program, DFHOCXCC, which is supplied in CICSTS55 .CICS.SDFHSAMP. For an example of how to omit the same parameters from the DPL call in the other supported languages, see the following sample programs:

#### **DFH\$AXCC**

The assembler sample

#### **DFH\$PXCC**

The PL/I sample

#### **DFH\$DXCC**

The C sample.

## The EXCI EXEC CICS interface

The EXCI EXEC CICS interface provides several commands, for example, the **EXEC CICS LINK PROGRAM** command, which is a single composite command to invoke all the calls of the EXCI CALL

interface, and channel and container commands, which your program can issue in batch to process data and then pass the data on the **EXEC CICS LINK** program command or a call API **DPL\_REQUEST**.

This section describes:

- [LINK \(EXCI\)](#)
- [“Retries on an EXEC CICS LINK command” on page 38](#)
- [Translation required for EXEC CICS LINK command](#)
- [DELETE CHANNEL \(EXCI\)](#)
- [DELETE CONTAINER \(EXCI\)](#)
- [GET CONTAINER \(EXCI\)](#)
- [MOVE CONTAINER \(EXCI\)](#)
- [PUT CONTAINER \(EXCI\)](#)

## EXEC CICS LINK command (EXCI)

Link from an MVS client program to the specified server program in a server CICS region.

### Format

#### LINK

► LINK — PROGRAM — ( — name — ) — RETCODE — ( — data-area — ) —►

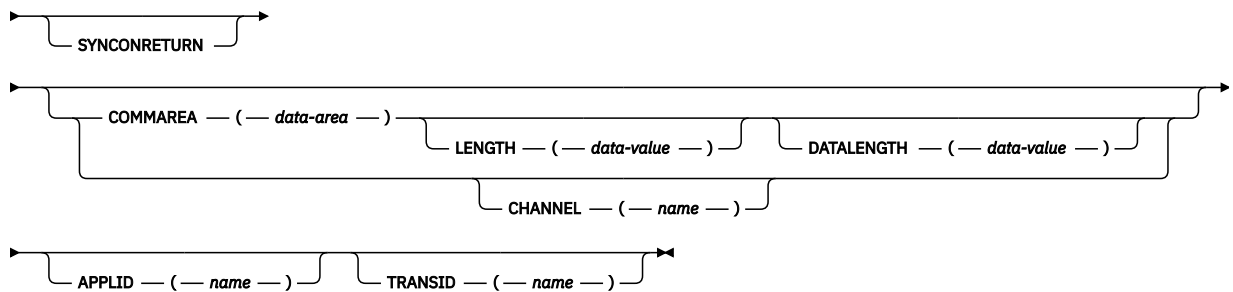

Notes:

**Error conditions:** CCSIDERR , CHANNELERR , CODEPAGEERR , CONTAINERERR , LENGERR, LINKERR, NOTAUTH, PGMIDERR, RESUNAVAIL, ROLLEDBACK, SYSIDERR, TERMERR, WARNING

### Comments

With the exception of the **APPLID** and **RETCODE** parameters, the external CICS interface parameters for an **EXEC CICS LINK** command are the same as for a CICS-CICS DPL command.

This information describes only those parameters that you can use with the external CICS interface. For programming information about the **EXEC CICS LINK PROGRAM** command, see [LINK](#).

Note that the **LENGTH** and **DATALENGTH** parameters specify halfword binary values, unlike the corresponding **COMMAREA\_len** and **data\_len** parameters of the EXCI CALL interface, which specify fullword values.

An external CICS interface **EXEC CICS LINK** command always uses a generic connection.

### Parameters

The parameters that you can use on the external CICS interface form of the **LINK** command, are as follows:

#### **APPLID**( name )

Specifies the APPLID of the target CICS server region.

Although an applid is required for an external CICS interface command, this parameter is optional on the LINK command itself because you can also specify it in the user-replaceable module, DFHXCURM. If you omit the generic APPLID from the LINK command, you must ensure it is specified by the user-replaceable module, DFHXCURM, on the **URMCICS** parameter. You can also use the **URMCICS** parameter in DFHXCURM to override an applid specified on the **LINK** command. See [The EXCI user-replaceable module](#) for information about the **URMCICS** parameter.

### **CHANNEL( *name* )**

Specifies the name (1 - 16 characters) of a channel that is to be made available to the called program. The acceptable characters are A - Z a - z 0 - 9 \$ @ # / % & ? ! : | " = ~ , ; < > . - and \_ . Leading and embedded blank characters are not permitted. If the name supplied is less than 16 characters, it is padded with trailing blanks up to 16 characters. If the channel does not exist, it is created. As there is only one LINK level for an EXCI client, this channel remains in scope. For more information about channel scope, see [The scope of a channel](#).

Channel names are always in EBCDIC. The set of allowed characters for channel names, as listed earlier, includes some characters that do not have the same representation in all EBCDIC code pages. Therefore, if channels are to be shipped between regions, it is advisable to restrict the characters that are used to name channels to A-Z a-z 0-9 & : = , ; < > . - and \_ .

You can specify the channel name DFHTRANSACTION to use a transaction channel. In CICS, a transaction channel does not go out of scope when the link level changes: it is always accessible in the transaction. For more information, see [Channels and containers](#).

The program that issues the **LINK** command can specify the name of a channel on the command. The specified channel might already exist, created by the program using one or more **PUT CONTAINER** commands. Alternatively, the program can specify the name of a channel that does not currently exist, in which case a new empty channel is created.

### **COMMAREA( *data-area* )**

Specifies a communication area that is to be made available to the invoked program. In this option, a pointer to the data area is passed.

See [Passing data to other programs](#) for more information about passing data to CICS application programs.

### **DATALENGTH( *data-value* )**

Specifies a halfword binary value that is the length of a contiguous area of storage from the start of the COMMAREA. If the amount of data in a COMMAREA is small, but the COMMAREA itself is large, specify DATALENGTH to improve performance.

### **LENGTH( *data-value* )**

Specifies a halfword binary value that is the length in bytes of the COMMAREA.

This value should not exceed 24 KB if the COMMAREA is to be passed between any two CICS servers (for any combination of product/version/release), otherwise, if you are confident that the COMMAREA will not be passed on a further LINK request, you can use a COMMAREA up to 32763 in length.

### **PROGRAM( *name* )**

Specifies the program name (1-8 characters) of the CICS server application program to which control is to be passed unconditionally. The specified name must either have been defined as a program to CICS , or the CICS server region must be capable of autoinstalling a definition for the named program.

Note the use of quotation marks:

```
EXEC CICS LINK PROGRAM('PROGX')
```

PROGX is in quotation marks because it is the program name.

```
EXEC CICS LINK PROGRAM(DAREA)
```

DAREA is not in quotes because it is the name of a data area that contains the 8-character program name.

**RETCODE( *data-area* )**

Specifies a 20-byte area into which the external CICS interface places return code information. This area is formatted into five 1-word fields as follows:

**RESP**

The primary response code indicating whether the external CICS interface LINK command caused an exception condition during its execution.

**RESP2**

The secondary response code that further qualifies, where necessary, some of the conditions raised in the RESP parameter.

**ABCODE**

Contains a valid CICS abend code if the server program abended in the server region.

**MSGLEN**

Indicates the length of the message (if any) issued by the CICS server region during the execution of the server program. Note that the length is the actual length of the message text only, and does not include this 1-word length field.

**MSGPTR**

This is the address of the message text returned by the CICS server region.

**Note:** MSGLEN and MSGPTR are only valid on a LINKERR condition, with the RESP2 value 414.

**SYNCONRETURN**

Specifies that the CICS server region, named on the APPLID parameter, is to take a syncpoint on successful completion of the server program.

**TRANSID( *name* )**

Specifies the name of the mirror transaction that the remote region is to attach, and under which it is to run the server program. If you omit the TRANSID option, the CICS server region attaches CSMI.

**Note:** The TRANSID option specified on the LINK command overrides any TRANSID option specified on the program resource definition installed in the CICS server region.

While you can specify your own name for the mirror transaction initiated by DPL requests, the transaction *must* be defined in the server region, and the transaction definition must specify the mirror program, DFHMIRS. Defining your own transaction to invoke the mirror program gives you the freedom to specify appropriate values for some other options on the transaction resource definition.

**See also the important rules about specifying transid with a DPL\_Request in . .**

**Error codes**

Most of the exception conditions that are returned on the external CICS interface LINK command are the same as for the CICS-to-CICS distributed program link command. Those that are the same, and their corresponding numeric values are as follows:

**LENGERR**

22

**PGMIDERR**

27

**SYSIDERR**

53

**NOTAUTH**

70

**TERMERR**

81

**ROLLEDBACK**

82

**CONTAINERERR**

110

**RESUNAVAIL**

121

**CHANNELERR**

122

**CCSIDERR**

123

**CODEPAGEERR**

125

These exception condition codes are returned in the RESP field.

**RESP and RESP2:** References to the RESP and RESP2 fields in this section are to the first two fields of the RETCODE parameter.

The exception conditions that are specific to the external CICS interface are as follows:

- The RESP2 values on the error condition LENGERR is specific to the external CICS interface.
- The exception conditions WARNING and LINKERR are specific to the external CICS interface.

The WARNING and LINKERR exceptions are a result of responses to individual EXCI calls issued by the external CICS interface in response to an **EXEC CICS LINK** command. These WARNING and LINKERR exceptions correspond to EXCI call responses as indicated in the descriptions.

**WARNING (RESP value 4)**

This is returned when the EXCI module handling the **EXEC CICS LINK** request receives a USER\_ERROR or SYSTEM\_ERROR response to a Close\_Pipe or Deallocate\_Pipe request issued on behalf of an **EXEC CICS LINK** command. The RESP value is set to WARNING because the DPL request to CICS completed successfully, but an error occurred in subsequent processing.

The RESP2 field is set to the EXCI reason code, which gives more information about the error.

**LINKERR (RESP value 88)**

This is returned when the EXCI module handling the **EXEC CICS LINK** request receives a RETRYABLE, USER\_ERROR, or SYSTEM\_ERROR response to an EXCI call issued on behalf of the **EXEC CICS LINK** command. The DPL request has failed. The RESP2 field is set to the EXCI reason code, which gives more information about the error.

See [Response and reason codes returned on EXCI calls](#) for descriptions of EXCI reason codes.

**Note:** The external CICS interface ignores any WARNING conditions that occur in response to EXCI calls it issues on behalf of an **EXEC CICS LINK** command. It treats the WARNING on an EXCI call as a good response and continues normally. If no other errors occur, the **EXEC CICS** command completes with a zero response in the EXEC\_RESP field.

**Retries on an EXEC CICS LINK command**

If the external CICS interface receives a RETRYABLE response on an EXCI call that it makes on behalf of an **EXEC CICS LINK** command, it automatically retries the **EXEC CICS LINK** command up to five times, providing more serious errors do not occur.

If the RETRYABLE response is still received after the fifth retry, the RESP field is set to LINKERR, and the reason returned on the EXCI CALL request that causes the exception is returned in the RESP2 field.

The external CICS interface retries the **EXEC CICS LINK** command by first closing and deallocating the pipe, then reissuing the six EXCI CALL commands. During Allocate\_Pipe processing, the EXCI CALL interface calls the user-replaceable module, DFHXCURM, to give you the opportunity to change the APPLID of the CICS system to which the request has been sent. See [The EXCI user-replaceable module](#) for details of DFHXCURM.

[Table 6 on page 39](#) lists all the exception conditions and RESP2 values that are specific to the **EXEC CICS LINK** command for the external CICS interface.

Table 6. Exception conditions. RESP and RESP2 values returned from the EXEC API.

Condition (RESP)	RESP2	Meaning
LENGERR (22)	22	COMMAREA length greater than 32763 bytes specified
	23	COMMAREA specified but no LENGTH parameter specified
WARNING (4)	401	Invalid <i>call_type</i> parameter value specified on Close_Pipe or Deallocate_Pipe call
	402	Invalid <i>version_number</i> parameter specified on Close_Pipe or Deallocate_Pipe call
	404	Invalid <i>user_token</i> specified on Close_Pipe or Deallocate_Pipe call
	405	A Deallocate_Pipe call has been issued against a pipe that is not yet closed
	418	An invalid pipe token has been issued on a Close_Pipe or Deallocate_Pipe call
	421	A Close_Pipe or Deallocate_Pipe command has been issued under an IRB
	610	There has been a CICS IRP logoff failure on a Deallocate_Pipe call
	611	There has been a CICS IRC disconnect failure on a Close_Pipe call
	622	There has been an MVS ESTAE setup failure on a Close_Pipe or Deallocate_Pipe call
	623	A program check on a Close_Pipe or Deallocate_Pipe call has caused the ESTAE to be invoked
	LINKERR (88)	201
202		There are no available sessions
203		CICS has not yet been brought up, or (2) has not yet opened IRC, or (3) no generic connection is installed, or (4) no specific connection is installed with the required netname.
204		An EXEC CICS LINK command without the SYNCONRETURN option has been issued specifying a CICS system on a different MVS image.
205		An EXEC CICS LINK command without the SYNCONRETURN option has been issued when RRS is not available
401		Invalid parameter
402		Invalid version number
403		User name is all blanks
404		Invalid address in user token
405		Command has been issued against a pipe that is not closed
406		Command has been issued against a pipe that is not open
407		Userid of all blanks has been passed
408		Error in UOWID parameter
LINKERR (88)	409	Transid consisting of all blanks or zero has been passed
	410	Load of message module, DFHMEBMX, failed
	411	Load of message module, DFHMET4E, failed
	412	Load of DFHXCURM failed

Table 6. Exception conditions. RESP and RESP2 values returned from the EXEC API. (continued)

Condition (RESP)	RESP2	Meaning
	413	Load of DFHXCTRA failed
	414	If run as a CICS-to-CICS linked-to program, this server program would have resulted in an error with an appropriate message sent to the terminal. Running the program as an EXCI server program returns the message addressed by the MSGPTR field of the RETCODE area.
	415	Target connection is an MRO connection, not an EXCI connection
	416	Command has been issued against a CICS region running under a release of CICS earlier than CICS for MVS/ESA 4.1
	417	Command has been issued against a pipe in the MUST CLOSE state. Further EXCI EXEC CICS LINK commands will have unpredictable results and are, therefore, not permitted
	418	Pipe_token does not address an XCPIPE control block, or there is a mismatch between user_token and pipe_token
	419	CICS runs, or did run, under the TCB that this command is attempting to use. This is not permitted and the command fails
	420	Load of DFHXCOPT failed
	421	The command has been issued under an MVS IRB, which is not permitted
	422	The server has abended
	423	Surrogate user check failed
	424	An EXEC CICS LINK command without the SYNCONRETURN option has been issued on a system that does not support RRMS
	425	A DPL request omitted the SYNCONRETURN option, but specified a value of UOWID.
	601	A GETMAIN of working storage failed. This error leads to user abend 408
	602	A GETMAIN failed. This error leads to user abend 403.
	603	A GETMAIN failed. This error leads to user abend 410
	604	A GETMAIN failed
	605	A GETMAIN for the VERIFY block failed. This error leads to user abend 409.
	606	An SSI verify request (to obtain CICS SVC instruction) failed. This error leads to user abend 405.
	607	An SVC call failed. This error leads to user abend 406.
	608	Logon to IRP failed
	609	Connect to IRP failed
	610	Disconnect from IRP failed
	611	Logoff from IRP failed
	612	Invalid data input to transformer_1
	613	Invalid data input to transformer_4
LINKERR (88)	614	CICS has responded but has not sent any data
	615	CICS cannot satisfy the request



Table 6. Exception conditions. RESP and RESP2 values returned from the EXEC API. (continued)

Condition (RESP)	RESP2	Meaning
	616	IRP_SWITCH_PULL request (to read data sent from CICS into a larger input/output area) has failed
	617	A GETMAIN for a larger input/output area failed
	619	IRP has had a problem with the input/output area passed from the client program
	620	IRP has disconnected from EXCI
	621	A DISCONNECT command is issued in an error situation following an IRP CONNECT. The DISCONNECT has failed, indicating a serious error.
	622	XCPRH ESTAE setup command failed This error leads to user abend 402.
	623	XCPRH ESTAE invoked due to program check during the processing of this command. ESTAE attempts backout and takes a SYSMDUMP. Further requests are permitted although the pipe is now in a MUST CLOSE state.
	624	The DPL request has been passed to CICS but the time specified in DFHXCOPT has been exceeded. The request is canceled.
	625	An MVS STIMERM macro call failed.
	626	An MVS STIMERM CANCEL request failed.
	627	The CICS SVC is at the incorrect level. This error leads to user abend 407.
	628	DFHIRP is at the incorrect level.
	629	A response to a DPL request has been returned by CICS but the external CICS interface does not understand the response.
	630	An unexpected return code was received from RRMS when processing an <b>EXEC CICS LINK</b> command without the SYNCONRETURN option.
	631	An unexpected error was encountered when processing an <b>EXEC CICS LINK</b> command without the SYNCONRETURN option.
	632	A GETMAIN for DFHXCGUR's working storage failed while processing an <b>EXEC CICS LINK</b> command without the SYNCONRETURN option.
	633	An INQUIRE_CHANNEL request to obtain the channel token failed due to an external CICS interface error.
	903	An XCEIP ESTAE setup command failed.
	904	XCEIP ESTAE invoked.

See [Return codes](#) for details of the various copybooks that contain full details of all response and reason codes, including equated values.

**Note:** All numeric response and reason code values are shown in decimal.

### Translation required for EXEC CICS LINK command

Application programs that use the **EXEC CICS LINK** form of the external CICS interface command must translate their programs before assembly or compilation. You do this using the version of the CICS translator that is appropriate for the language of your client program, specifying the translator option EXCI.

The translator option EXCI is mutually exclusive with the CICS and DLI options.

For more information about translating programs that contain EXEC CICS commands, see [The CICS-supplied translators](#).

For information about compiling and link-editing external CICS interface client programs, see [Compiling and link-editing EXCI client programs](#).

## EXEC CICS DELETE CHANNEL command (EXCI)

Delete a named channel and all the containers that are in it.

### DELETE CHANNEL (EXCI)

➤ DELETE CHANNEL( *data-value* ) — RETCODE( *data-area* ) ➤

**Conditions:** CHANNELERR

### Description

**DELETE CHANNEL (EXCI)** deletes the specified channel and all the containers that are in it. When you delete a channel and its containers:

- Any data that is in the containers is discarded.
- All storage that relates to the channel and to its containers is released.

The application program that issues the **DELETE CHANNEL** command must be the program that owns the channel. The program that owns the channel is the program that created the channel by naming it on one of the following commands:

- **LINK PROGRAM CHANNEL**
- **MOVE CONTAINER CHANNEL TOCHANNEL**
- **PUT CONTAINER CHANNEL**

An application program cannot delete the following channels:

- Any channel that the application program did not create
- Any channel that is read-only
- The transaction channel DFHTRANSACTION

### Options

#### CHANNEL(*data-value*)

Specifies the 1–16 character name of the channel that is to be deleted. Every container that is owned by the channel is deleted, and the channel itself is deleted.

#### RETCODE(*data-area*)

Specifies a 20-byte area into which the external CICS interface places return information. This area is formatted into five 1–word fields. This command will return information in the first two words. These words will contain the RESP and RESP2 codes. The other three words will be set to nulls.

#### **RESP**

The primary response code, which indicates whether the external CICS interface **DELETE CHANNEL** command caused an exception condition during its execution.

#### **RESP2**

The secondary response code that further qualifies, where necessary, some of the conditions that are raised in the *RESP* parameter.

### Conditions

#### 122 CHANNELERR

RESP2 values:

- 2** The channel specified on the **CHANNEL** option could not be found.
- 3** The channel specified on the **CHANNEL** option is a read-only channel.
- 5** The channel specified on the **CHANNEL** option is the transaction channel.
- 6** The channel specified on the **CHANNEL** option is not owned by the calling program.
- 904** XCEIP ESTAE invoked.

## EXEC CICS DELETE CONTAINER command (EXCI)

Delete a named channel container.

### DELETE CONTAINER (EXCI)

➤ DELETE — CONTAINER( *data-value* ) — CHANNEL( *data-value* ) — RETCODE( *data-area* ) —◀

**Conditions:** CHANNELERR, CONTAINERERR, INVREQ

### Description

**DELETE CONTAINER (EXCI)** deletes a container from a channel and discards any data that it contains.

The container is identified by name and by the channel for which it is a container - the channel that “owns” it.

### Options

#### CHANNEL(*data-value*)

Specifies the name (1–16 characters) of the channel that owns the container. You can specify the channel name DFHTRANSACTION to use the transaction channel.

#### CONTAINER(*data-value*)

Specifies the name (1–16 characters) of the container to be deleted.

#### RETCODE(*data-area*)

Specifies a 20-byte area into which the external CICS interface places return information. This area is formatted into five 1–word fields. This command will return information in the first two words. These words will contain the RESP and RESP2 codes. The other three words will be set to nulls.

#### RESP

The primary response code, which indicates whether the external CICS interface **DELETE CONTAINER** command caused an exception condition during its execution.

#### RESP2

The secondary response code that further qualifies, where necessary, some of the conditions that are raised in the *RESP* parameter.

### Conditions

#### 122 CHANNELERR

RESP2 values:

- 2** The channel specified on the **CHANNEL** option could not be found.
- 3** The channel specified on the **CHANNEL** option is read-only.
- 904** XCEIP ESTAE invoked.

### 110 CONTAINERERR

RESP2 values:

**10**

The container named on the **CONTAINER** option could not be found.

### 16 INVREQ

RESP2 values:

**4**

The command was issued outside the scope of a currently-active channel.

**30**

You cannot delete a CICS-defined read-only container.

## EXEC CICS ENDBROWSE CONTAINER command (EXCI)

End a browse of the containers that are associated with a channel.

### ENDBROWSE CONTAINER (EXCI)

➤ ENDBROWSE — CONTAINER — BROWSETOKEN( *data-value* ) — RETCODE( *data-area* ) ➤

**Conditions:** TOKENERR

### Description

**ENDBROWSE CONTAINER (EXCI)** ends a browse of the containers that are associated with a channel, and invalidates the browse token.

### Options

#### **BROWSETOKEN(data-value)**

Specifies, as a fullword binary value, the browse token to be deleted.

#### **RETCODE(data-area)**

Specifies a 20-byte area into which the external CICS interface places return information. This area is formatted into five 1-word fields. This command will return information in the first two words. These words will contain the RESP and RESP2 codes. The other three words will be set to nulls.

#### **RESP**

The primary response code, which indicates whether the external CICS interface **ENDBROWSE CONTAINER** command caused an exception condition during its execution.

#### **RESP2**

The secondary response code that further qualifies, where necessary, some of the conditions that are raised in the *RESP* parameter.

### Conditions

#### 112 TOKENERR

RESP2 values:

**3**

The browse token is not valid.

# EXEC CICS GET CONTAINER command (EXCI)

Retrieve data from a named channel container.

## GET CONTAINER (EXCI)

➔ GET — CONTAINER( *data-value* ) — CHANNEL( *data-value* ) ➔

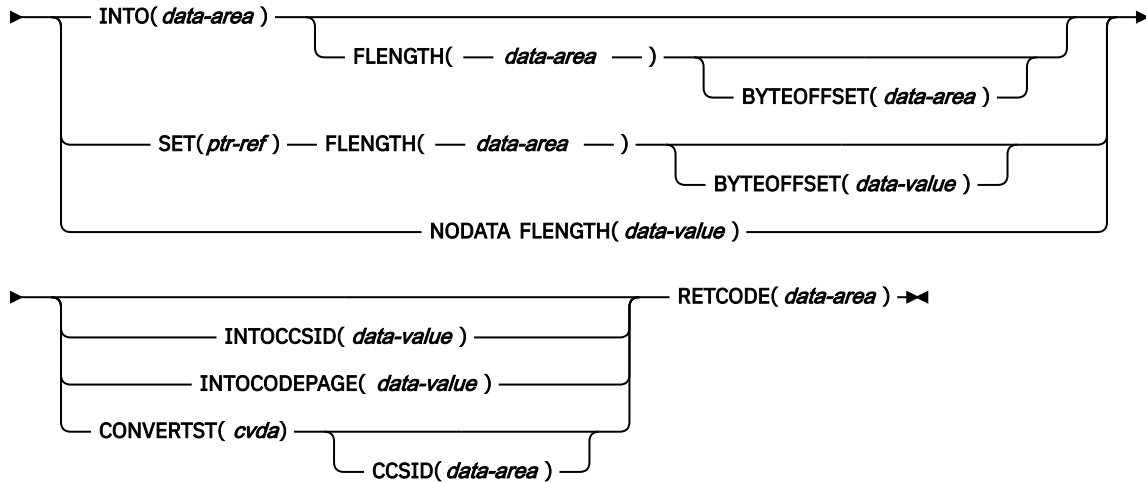

**Conditions:** CCSIDERR, CHANNELERR, CODEPAGEERR, CONTAINERERR, INVREQ, LENGERR

## Description

**GET CONTAINER (EXCI)** reads the data associated with a specified channel container.

The container that holds the data is identified by name and by the channel for which it is a container; the channel that "owns" it.

## Options

### BYTEOFFSET( *data-value* )

Specifies the offset in bytes where the data returned starts. For CHAR containers, the **BYTEOFFSET** value is used as an offset into the data in the requested code page. If you use a code page with multibyte characters, depending on the **BYTEOFFSET** value you specify, the data returned might have partial characters at the beginning, end, or both. In this situation, your application program must be able to handle and interpret the data returned. If the value specified is less than zero, zero is assumed.

### CCSID( *data-area* )

Returns a fullword that contains the Coded Character Set Identifier (CCSID) of the data returned by the **CONVERTST( NOCONVERT )** option. You can use this option to retrieve containers with a DATATYPE of CHAR, without converting the data. If a DATATYPE of BIT is specified for the container, this value is zero.

### CHANNEL( *data-value* )

Specifies the name (1 - 16 characters) of the channel that owns the container. You can specify the channel name DFHTRANSACTION to use the transaction channel.

### CONTAINER( *data-value* )

Specifies the name (1 - 16 characters) of the container that holds the data to be retrieved.

### CONVERTST( *cvda* )

Specifies the required data conversion status.

### NOCONVERT

The container data is retrieved without being converted.

### **FLENGTH( data-area )**

As an input field, **FLENGTH** specifies, as a fullword binary value, the length of the data to be read. As an output field, **FLENGTH** returns the length of the data in the container. **FLENGTH** is an input or an output field depending on which of the **BYTEOFFSET** , **INTO** , **SET** , or **NODATA** options you specify.

#### **BYTEOFFSET option specified**

**FLENGTH** is both an input and an output field.

On **input** , **FLENGTH** specifies the maximum length of the data that the program accepts. The data returned begins at the offset specified by the **BYTEOFFSET** value. If the value specified is less than zero, zero is assumed.

On **output** (that is, on completion of the retrieval operation) CICS sets the data area to the length of the data returned. The maximum length returned is equal to the length of the data in the container minus the **BYTEOFFSET** value.

#### **INTO option specified**

**FLENGTH** is both an input and an output field.

On **input** , **FLENGTH** specifies the maximum length of the data that the program accepts. If the value specified is less than zero, zero is assumed. If the length of the data exceeds the value specified, the data is truncated to that value and the **LENGERR** condition occurs. If the length of the data is less than the specified value, the data is copied but no padding is performed.

You do not need to specify **FLENGTH** if the length can be generated by the compiler from the **INTO** variable. If you specify both **INTO** and **FLENGTH** , **FLENGTH** specifies the maximum length of the data that the program accepts.

On **output** (that is, on completion of the retrieval operation) CICS sets the data area, if specified, to the actual length of the data in the container. If the container holds character data that has been converted from one CCSID to another, this is the length of the data after conversion.

#### **SET or NODATA option specified**

**FLENGTH** is an output-only field. It must be present and must be specified as a data-area.

On completion of the retrieval operation, the data area is set to the actual length of the data in the container. If the container holds character data that has been converted from one CCSID to another, this is the length of the data after conversion.

### **INTO( data-area )**

Specifies the data area into which the retrieved data is placed.

### **INTOCCSID( data-value )**

Specifies the Coded Character Set Identifier (CCSID) into which the character data in the container is converted, as a fullword binary number. If you prefer to specify an IANA name for the code page, or if you prefer to specify the CCSID as alphanumeric characters, use the **INTOCODEPAGE** option instead.

For CICS Transaction Server for z/OS applications, the CCSID is typically an EBCDIC CCSID. However, it is possible to specify an ASCII CCSID if, for example, you want to retrieve ASCII data without it being automatically converted to EBCDIC.

If **INTOCCSID** and **INTOCODEPAGE** are not specified, the value for conversion defaults to the CCSID of the EXCI job. The default CCSID of the EXCI job is specified on the **LOCALCCSID** parameter of **DFHXCPT**.

Only character data can be converted, and only then if a **DATATYPE** of **CHAR** was specified on the **PUT CONTAINER** command used to place the data in the container. A **DATATYPE** of **CHAR** is implied if **FROMCCSID** or **FROMCODEPAGE** is specified on the **PUT CONTAINER** command.

For more information about data conversion with channels, see [Data conversion with channels](#).

For an explanation of CCSIDs, see [Preparing for code page conversion with channels](#).

### **INTOCODEPAGE( data-value )**

Specifies an IANA-registered alphanumeric charset name or a Coded Character Set Identifier (CCSID) for the code page into which the character data in the container is to be converted, using up to 40

alphanumeric characters, including appropriate punctuation. Use this option instead of the CCSID option if you prefer to use an IANA-registered charset name, as specified in the Content-Type header for an HTTP request. CICS converts the IANA name into a CCSID, and the subsequent data conversion process is identical. Also use this option if you prefer to specify the CCSID in alphanumeric characters, rather than as a fullword binary number.

Where an IANA name exists for a code page and CICS supports its use, the name is listed with the CCSID. For more information, see [Preparing for code page conversion with channels](#).

### **NODATA**

Specifies that no data is retrieved. Use this option to discover the length of the data in the container (returned in **FLENGTH**).

The length of character data may change if data conversion takes place. Therefore, if character data is to be converted into any CCSID *other than that of this region*, when you specify **NODATA**, you should also specify **INTOCCSID**. This ensures that the correct length of the converted data is returned in **FLENGTH**.

### **RETCODE(data-area)**

Specifies a 20-byte area into which the external CICS interface places return information. This area is formatted into five 1-word fields. This command will return information in the first two words. These words will contain the RESP and RESP2 codes. The other three words will be set to nulls.

#### **RESP**

The primary response code, which indicates whether the external CICS interface **GET CONTAINER** command caused an exception condition during its execution.

#### **RESP2**

The secondary response code that further qualifies, where necessary, some of the conditions that are raised in the *RESP* parameter.

### **SET(ptr-ref)**

Specifies a data area in which the address of the retrieved data is returned.

The external CICS interface maintains the data area until any of the following occurs:

- A subsequent **GET CONTAINER** command with the **SET** option, for the same container in the same channel, is issued by any program that can access this storage.
- The container is deleted by a **DELETE CONTAINER** command.
- The container is moved by a **MOVE CONTAINER** command.
- The channel and the containers that are in it are deleted by a **DELETE CHANNEL** command.

Beware of linking to other programs that might issue one of these commands.

Do not issue a **FREEMAIN** command to release this storage.

If your application needs to keep the data, the application should move the data into its own storage.

## **Conditions**

### **123 CCSIDERR**

RESP2 values:

#### **1**

The CCSID specified on the **INTOCCSID** option is outside the range of valid CCSID values.

#### **2**

The CCSID specified on the **INTOCCSID** option and the CCSID of the container are an unsupported combination. (The CCSID of the container is the value that was specified using either **FROMCODEPAGE** or **FROMCCSID**, or defaulted, when the container was built.)

#### **3**

The data was created with a data type of BIT. Code page conversion is not possible. The data was returned without any code page conversion.

4

One or more characters could not be converted. The character has been replaced by a blank in the converted data.

5

There was an internal error in the code page conversion of a container.

#### **122 CHANNELERR**

RESP2 values:

2

The channel specified on the **CHANNEL** option could not be found.

904

XCEIP ESTAE invoked.

#### **125 CODEPAGEERR**

RESP2 values:

1

The code page specified on the **INTOCODEPAGE** option is not supported.

2

The code page specified on the **INTOCODEPAGE** option and the code page of the channel are an unsupported combination.

3

The data was created with a data type of BIT. Code page conversion is not possible. The data was returned without any code page conversion.

4

One or more characters could not be converted. The character has been replaced by a blank in the converted data.

5

There was an internal error in the code page conversion of a container.

#### **110 CONTAINERERR**

RESP2 values:

10

The container named on the **CONTAINER** option could not be found.

#### **16 INVREQ**

RESP2 values:

2

The **INTOCCSID** option was specified without the **CHANNEL** option, and there is no current channel (because the program that issued the command was not passed one.) **INTOCCSID** is valid only on **GET CONTAINER** commands that specify a channel.

4

The **CHANNEL** option was not specified, there is no current channel (because the program that issued the command was not passed one), and the command was issued outside the scope of a currently-active BTS activity.

5

The CONVERTST cvda value is invalid.

#### **22 LENGERR**

RESP2 values:

11

The length of the program area is shorter than the length of the data in the container. When the area is smaller, the data is truncated to fit into it.

12

The offset is greater than, or equal to, the length of the container.



## EXEC CICS GETNEXT CONTAINER command (EXCI)

Browse the containers that are associated with a channel.

### GETNEXT CONTAINER (EXCI)

➤ GETNEXT — CONTAINER( *data-area* ) — BROWSETOKEN( *data-value* ) — RETCODE( *data-area* ) ➤

**Conditions:** END, TOKENERR

### Description

**GETNEXT CONTAINER (EXCI)** returns the name of the next container that is associated with a channel.

#### Note:

1. You can use successive **GETNEXT CONTAINER (EXCI)** commands to retrieve the names of all the channel's containers that existed when the **STARTBROWSE CONTAINER (EXCI)** command was run. However, the names of any containers that are deleted after the **STARTBROWSE** command and before they were returned by a **GETNEXT** command are not returned.
2. The names of any containers that are created on (or moved to) this channel or activity after the **STARTBROWSE** command is run might, or might not, be returned.
3. The order in which containers are returned is undefined and might change. As best practice, applications should not rely on the order of returned containers.

### Options

#### **BROWSETOKEN(data-value)**

Specifies, as a fullword binary value, a browse token returned on a previous **STARTBROWSE CONTAINER (EXCI)** command.

#### **CONTAINER(data-area)**

Returns the 16-character name of the next data-container.

#### **RETCODE(data-area)**

Specifies a 20-byte area into which the external CICS interface places return information. This area is formatted into five 1–word fields. This command will return information in the first two words. These words will contain the RESP and RESP2 codes. The other three words will be set to nulls.

#### **RESP**

The primary response code, which indicates whether the external CICS interface **GETNEXT CONTAINER** command caused an exception condition during its execution.

#### **RESP2**

The secondary response code that further qualifies, where necessary, some of the conditions that are raised in the *RESP* parameter.

### Conditions

#### **83 END**

RESP2 values:

**2**

There are no more containers.

#### **112 TOKENERR**

RESP2 values:

**3**

The browse token is not valid.

## EXEC CICS MOVE CONTAINER command (EXCI)

Move a container (and its contents) from one channel to another.

### MOVE CONTAINER (EXCI)

```
►► MOVE — CONTAINER( data-value ) — AS( data-value ) — CHANNEL( data-value ) —►  
  
    ◄◄ TOCHANNEL( data-value ) — RETCODE( data-area ) —◄◄
```

**Conditions:** CHANNELERR, CONTAINERERR, INVREQ

### Description

**MOVE CONTAINER (EXCI)** moves a container from one channel to another. After the move, the source container no longer exists.

The source and target containers are identified by name and by the channels that own them. The channel that owns the source container is identified by the **CHANNEL** option. The channel that owns the target container is identified by the **TOCHANNEL** option.

You can move a container:

- From one channel to another
- Within the same channel (This has the effect of renaming the container.)

You can use **MOVE CONTAINER**, instead of **GET CONTAINER** and **PUT CONTAINER**, as a more efficient way of transferring data between channels.

### Note:

1. The source channel must be within the scope of the program that issues the **MOVE CONTAINER** command.
2. If the target channel does not exist, within the scope of the program that issues the **MOVE CONTAINER** command, it is created.
3. If the source container does not exist, an error occurs.
4. If the target container does not already exist, it is created. If the target container already exists, its previous contents are overwritten.
5. If you try to overwrite a container with itself, nothing happens. That is, if you specify the same value for the **CONTAINER** and **AS** options and specify the same value for the **CHANNEL** and **TOCHANNEL** options, so that the same channel is specified, the source container is not changed nor deleted. No error condition is raised.

### Options

#### AS(*data-value*)

Specifies the name (1–16 characters) of the target container. If the target container already exists, its contents are overwritten.

The acceptable characters are A-Z a-z 0-9 \$ @ # / % & ? ! : | " = ~ , ; < > . - and \_ . Leading and embedded blank characters are not permitted. If the name supplied is less than 16 characters, it is padded with trailing blanks up to 16 characters.

Container names are always in EBCDIC. The allowable set of characters for container names, listed above, includes some characters that do not have the same representation in all EBCDIC code pages. Therefore, it is recommended that, if containers are to be shipped between regions, the characters used in naming them should be restricted to A-Z a-z 0-9 & : = , ; < > . - and \_ .

#### CHANNEL(*data-value*)

Specifies the name (1–16 characters) of the channel that owns the source container. You can specify the channel name DFHTRANSACTION to use the transaction channel.

**CONTAINER(data-value)**

Specifies the name (1–16 characters) of the source container that is to be moved.

**RETCODE(data-area)**

Specifies a 20-byte area into which the external CICS interface places return information. This area is formatted into five 1–word fields. This command will return information in the first two words. These words will contain the RESP and RESP2 codes. The other three words will be set to nulls.

**RESP**

The primary response code, which indicates whether the external CICS interface **MOVE CONTAINER** command caused an exception condition during its execution.

**RESP2**

The secondary response code that further qualifies, where necessary, some of the conditions that are raised in the *RESP* parameter.

**TOCHANNEL(data-value)**

Specifies the name (1–16 characters) of the channel that owns the target container. If you are specifying a new channel, remember that the acceptable characters are A-Z a-z 0-9 \$ @ # / % & ? ! : | " = ~ , ; < > . - and \_ . Leading and embedded blank characters are not permitted. If the name supplied is less than 16 characters, it is padded with trailing blanks up to 16 characters. If the channel does not exist, it is created. This new channel remains in scope until the link level changes. For more information about channel scope, see [The scope of a channel](#).

Channel names are always in EBCDIC. The allowable set of characters for channel names, listed above, includes some characters that do not have the same representation in all EBCDIC code pages. Therefore, if channels are to be shipped between regions, it is advisable to restrict the characters that are used to name them to A-Z a-z 0-9 & : = , ; < > . - and \_ .

You can specify the channel name DFHTRANSACTION to use a transaction channel. A transaction channel does not go out of scope when the link level changes: it is always accessible in the task. For more information, see [Channels and containers](#).

**Conditions****122 CHANNELERR**

RESP2 values:

**1**

The name specified on the **TOCHANNEL** option contains an illegal character or combination of characters.

**2**

The channel specified on the **CHANNEL** option could not be found.

**3**

The channel specified on the **CHANNEL** option is read-only.

**904**

XCEIP ESTAE invoked.

**110 CONTAINERERR**

RESP2 values:

**10**

The container named on the **CONTAINER** option could not be found.

**18**

The name specified on the **AS** option contains an illegal character or combination of characters.

**16 INVREQ**

RESP2 values:

**30**

You cannot move a CICS-defined read-only container.

You cannot move a container to (that is, overwrite) an existing, CICS-defined, read-only container.

## EXEC CICS PUT CONTAINER command (EXCI)

Place data in a named channel container.

### PUT CONTAINER (EXCI)

►► PUT — CONTAINER( *data-value* ) — CHANNEL( *data-value* ) — FROM( *data-area* ) —►

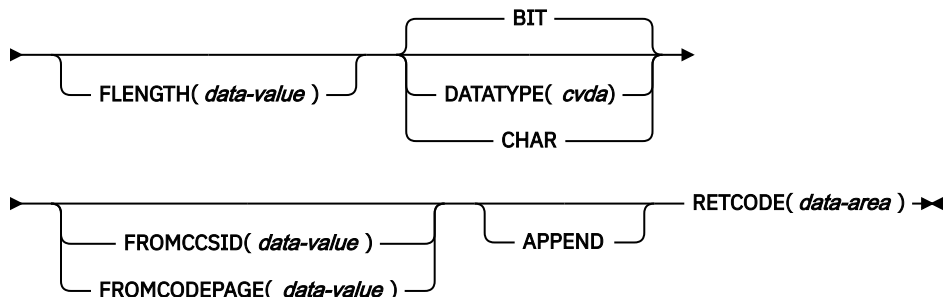

**Conditions:** CCSIDERR, CHANNELERR, CODEPAGEERR, CONTAINERERR, INVREQ, LENGERR

### Description

**PUT CONTAINER (EXCI)** places data in a container associated with a specified channel.

The container is identified by name. The channel that owns the container is identified by the **CHANNEL** option.

If the named container does not exist, it is created. If the named container exists, its previous contents are overwritten, unless you specify the **APPEND** option. If the named channel does not exist, it is created.

There is no limit to the number of containers that can be associated with a channel. The size of individual containers is limited only by the amount of storage available. Container data is held in 64-bit storage. The total amount of 64-bit storage available to an EXCI job is governed by **MEMLIMIT**, and the external CICS interface limits the total amount of container data to 5% of the **MEMLIMIT** value.



**CAUTION:** If you create multiple large containers and pass them to CICS, unless the target CICS program is a non-LE assembler amode-64 application, the container data will be copied into 31-bit storage when accessed by the CICS application, so sufficient 31-bit storage must be available to contain the copied data, and you might limit the amount of storage available to other CICS applications.

### Options

#### APPEND

Specifies that the data passed to the container is appended to the existing data in the container. If this option is not stated, the existing data in the container is overwritten by the data passed to the container.

#### CHANNEL( *data-value* )

Specifies the name (1–16 characters) of the channel that owns the container. The acceptable characters are A-Z a-z 0-9 \$ @ # / % & ? ! : | " = , ; < > . - and \_. Leading and embedded blank characters are not permitted. If the name supplied is less than 16 characters, it is padded with trailing blanks up to 16 characters.

Channel names are always in EBCDIC. The set of allowed characters for channel names, as listed earlier, includes some characters that do not have the same representation in all EBCDIC code pages. Therefore, if channels are to be shipped between regions, it is advisable to restrict the characters that are used to name them to A-Z a-z 0-9 & : = , ; < > . - and \_.

If the channel does not exist, it is created. You can specify the channel name DFHTRANSACTION to use a transaction channel in CICS. For more information about using a transaction channel with EXCI, see [Channels and containers](#).

### **CONTAINER( *data-value* )**

Specifies the name (1–16 characters) of the container into which data is placed.

The acceptable characters are A-Z a-z 0-9 \$ @ # / % & ? ! : | " = , ; < > . - and \_ . Leading and embedded blank characters are not permitted. If the name supplied is less than 16 characters, it is padded with trailing blanks up to 16 characters.

Do not use container names that begin with DFH, unless requested to do so by CICS.

Container names are always in EBCDIC. The set of allowed characters for container names, as listed earlier, includes some characters that do not have the same representation in all EBCDIC code pages. Therefore, if containers are to be shipped between regions, it is advisable to restrict the characters used to name them to A-Z 0-9 & : = , ; < > . - and \_ .

### **DATATYPE( *cvda* )**

Specifies the type of data to put into the container. This option applies only to new containers. If the container exists, its data type was established when it was created and cannot be changed. CVDA values are:

#### **BIT**

Bit data. The data in the container cannot be converted. This is the default value, unless **FROMCCSID** is specified.

#### **CHAR**

Character data. The data to store in the container is converted (if required) according to the setting in the **FROMCCSID** or **FROMCODEPAGE** value. If the **FROMCCSID** and **FROMCODEPAGE** options are not specified, it is assumed that the data is encoded in the CCSID of the EXCI job as specified in the **LOCALCCSID** parameter of DFHXCOPT.

All the data in a container is converted as if it were a single character string. For SBCS code pages, a structure consisting of several character fields is equivalent to a single-byte character string. However, for DBCS code pages this is not the case. If you use DBCS code pages, you must put each character string into a separate container to ensure that data conversion works correctly.

### **FLENGTH( *data-value* )**

Specifies, as a fullword binary value, the length of the data area from which data is read.

### **FROM( *data-area* )**

Specifies the data area from which the data is written to the container.

### **FROMCCSID( *data-value* )**

Specifies the current Coded Character Set Identifier (CCSID) of the character data to put into the container, as a fullword binary number. If you prefer to specify an IANA name for the code page, or if you prefer to specify the CCSID as alphanumeric characters, use the **FROMCODEPAGE** option instead. Use this option if the data to place in the container is not encoded in the CCSID of the EXCI job, as specified in the **LOCALCCSID** parameter of DFHXCOPT.

If the FROMCCSID option is specified, DATATYPE(DFHVALUE(CHAR)) is implied.

### **FROMCODEPAGE( *data-value* )**

Specifies an IANA-registered alphanumeric charset name or a Coded Character Set Identifier (CCSID) for the current code page of the character data to put into the container, using up to 40 alphanumeric characters, including appropriate punctuation. Use this option instead of the CCSID option if you prefer to use an IANA-registered charset name, as specified in the Content-Type header for an HTTP request. CICS converts the IANA name into a CCSID, and the subsequent data conversion process is identical. Also use this option if you prefer to specify the CCSID in alphanumeric characters, rather than as a fullword binary number.

If the **FROMCODEPAGE** option is specified, DATATYPE(DFHVALUE(CHAR)) is implied.

## **RETCODE(data-area)**

Specifies a 20-byte area into which the external CICS interface places return information. This area is formatted into five 1–word fields. This command will return information in the first two words. These words will contain the *RESP* and *RESP2* codes. The other three words will be set to nulls.

### ***RESP***

The primary response code, which indicates whether the external CICS interface **PUT CONTAINER** command caused an exception condition during its execution.

### ***RESP2***

The secondary response code that further qualifies, where necessary, some of the conditions that are raised in the *RESP* parameter.

## **Conditions**

### **123 CCSIDERR**

*RESP2* values:

**1**

The CCSID specified on the **FROMCCSID** option is outside the range of valid CCSID values.

**2**

The CCSID specified on the **FROMCCSID** option and the CCSID of the container are an unsupported combination. The CCSID of the container is the value that was specified, or defaulted, on the first **PUT CONTAINER** command for this container. The first time each invalid combination is used, CICS issues error message DFHAP0802 , which contains the pair of CCSIDs.

**4**

One or more characters could not be converted. Each unconverted character has been replaced by a blank in the converted data.

**5**

There was an internal error in the code page conversion of a container. This error can occur only when the target of the PUT is an existing, CICS-created container.

### **122 CHANNELERR**

*RESP2* values:

**1**

The name specified on the **CHANNEL** option contains an illegal character or combination of characters.

**3**

The channel specified on the **CHANNEL** option is read-only.

**904**

XCEIP ESTAE invoked.

### **125 CODEPAGEERR**

*RESP2* values:

**1**

The code page specified on the **FROMCODEPAGE** option is not supported.

**2**

The code page specified on the **FROMCODEPAGE** option and the CCSID of the container are an unsupported combination. The CCSID of the container is the value that was specified using either **FROMCODEPAGE** or **FROMCCSID** , or defaulted, on the first **PUT CONTAINER** command for this container. The first time each invalid combination is used, CICS issues error message DFHAP0802 , which contains the pair of CCSIDs.

**4**

One or more characters could not be converted. Each unconverted character has been replaced by a blank in the converted data. This error can occur only when the target of the PUT is an existing container.

5

There was an internal error in the code page conversion of a container. This error can occur only when the target of the PUT is an existing, CICS-created container.

#### 110 CONTAINERERR

RESP2 values:

18

The name specified on the **CONTAINER** option contains an illegal character or combination of characters.

#### 16 INVREQ

RESP2 values:

1

The **DATATYPE** option was specified without the **CHANNEL** option, and there is no current channel (because the program that issued the command was not passed one.) **DATATYPE** is valid only on **PUT CONTAINER** commands that specify (explicitly or implicitly) a channel.

2

The **FROMCCSID** option was specified without the **CHANNEL** option, and there is no current channel (because the program that issued the command was not passed one.) **FROMCCSID** is valid only on **PUT CONTAINER** commands that specify (explicitly or implicitly) a channel.

30

You tried to write to a CICS-defined read only container.

32

A CVDA value other than CHAR or BIT was specified for **DATATYPE**.

33

An attempt was made to change the data-type of an existing container.

34

A data-type of BIT is invalid with a CCSID.

#### 22 LENGERR

RESP2 values:

1

A negative number was specified on the **FLENGTH** option.

## EXEC CICS QUERY CHANNEL command (EXCI)

Count the number of containers that are in a channel.

### QUERY CHANNEL (EXCI)

►► QUERY CHANNEL( *data-value* ) — CONTAINERCNT( *data-area* ) — RETCODE( *data-area* ) ◄◄

**Conditions:** CHANNELERR

### Description

**QUERY CHANNEL (EXCI)** counts the number of containers that are in a specified channel. You must specify the **CHANNEL** option and identify the channel explicitly. You can use the **QUERY CHANNEL** command with any channel, including the transaction channel (DFHTRANSACTION), and channels that EXCI created.

### Options

#### CHANNEL(*data-value*)

Specifies the 1-16 character name of the channel.

### **CONTAINERCNT(data-area)**

Returns, as a fullword binary value, a count of the number of containers that are in the specified channel.

### **RETCODE(data-area)**

Specifies a 20-byte area into which the external CICS interface places return information. This area is formatted into five 1-word fields. This command will return information in the first two words. These words will contain the RESP and RESP2 codes. The other three words will be set to nulls.

#### **RESP**

The primary response code, which indicates whether the external CICS interface **QUERY CHANNEL** command caused an exception condition during its execution.

#### **RESP2**

The secondary response code that further qualifies, where necessary, some of the conditions that are raised in the *RESP* parameter.

## **Conditions**

### **122 CHANNELERR**

RESP2 values:

**2**

The channel specified on the CHANNEL option could not be found.

## **EXEC CICS STARTBROWSE CONTAINER command (EXCI)**

Start a browse of the containers that are associated with a channel.

### **STARTBROWSE CONTAINER (EXCI)**

►► STARTBROWSE — CONTAINER — CHANNEL( *data-value* ) — BROWSETOKEN( *data-area* ) ►►  
◄◄ RETCODE( *data-area* ) ◄◄

**Conditions:** CHANNELERR

## **Description**

**STARTBROWSE CONTAINER (EXCI)** initializes a browse token that can be used to identify the name of each data-container that is associated with a specified channel.

**Note:** The browse token should be used only by the program that issues the **STARTBROWSE** command.

The order in which containers are returned is undefined and might change. As best practice, applications should not rely on the order of returned containers.

## **Options**

### **BROWSETOKEN(data-area)**

Specifies a fullword binary data area, into which CICS will place the browse token.

### **CHANNEL(data-value)**

Specifies the name (1-16 characters) of the channel whose containers are to be browsed. This must be the name of a channel created by the program that issues the **STARTBROWSE CONTAINER** command. You can specify the channel name DFHTRANSACTION to use the transaction channel.

The order in which containers are returned is undefined.

### **RETCODE(data-area)**

Specifies a 20-byte area into which the external CICS interface places return information. This area is formatted into five 1-word fields. This command will return information in the first two words. These words will contain the RESP and RESP2 codes. The other three words will be set to nulls.



### **RESP**

The primary response code, which indicates whether the external CICS interface **STARTBROWSE CONTAINER** command caused an exception condition during its execution.

### **RESP2**

The secondary response code that further qualifies, where necessary, some of the conditions that are raised in the *RESP* parameter.

## **Conditions**

### **122 CHANNELERR**

RESP2 values:

#### **2**

The channel specified on the CHANNEL option could not be found.

## **Compiling and link-editing EXCI client programs**

All programs that use the external CICS interface to pass DPL requests to a CICS server region must include the CICS-supplied program stub, DFHXCSTB.

Alternatively for COBOL programs, it is possible to call DFHXCSTB dynamically rather than link-editing the stub with the program.

The stub intercepts all external CICS interface commands, whether they are EXCI CALL interface commands or EXEC CICS interface commands, and ensures they are passed to the appropriate external CICS interface routine for processing.

DFHXCSTB is a common stub, designed for inclusion in programs written in all the supported languages. It is supplied in the CICSTS55 .CICS.SDFHEXCI library.

**Note:** The CICSTS55 .CICS.SDFHEXCI also contains entries for DFHXCIE and DFHXCIS, which are aliases for DFHXCSTB.

To help you ensure that the stub is included, CICS provides a number of procedures, one for each language, which you can use for translating, compiling, and link-editing.

You must specify AMODE(31) for your EXCI client program.

The CICS-supplied procedures for compiling and link-editing client programs include the following parameters on the PARM statement of the linkage editor job step:

```
LNKPARM= ' AMODE(31) , LIST , XREF '
```

## **Samples**

To help with writing programs that use the external CICS interface, CICS provides sample MVS client programs and a sample CICS server program. The samples show you how to code client applications that use both the **EXCI CALL** interface and **EXEC CICS LINK** command. For more information, see [EXCI sample programs](#).

## **Job control language to run an EXCI client program**

An EXCI client program runs in an MVS address space, for example, as a batch job. When writing the JCL for your client program, you should note these requirements.

## **Requirements**

- Include in the STEPLIB concatenation those libraries that contain the CICS-supplied external CICS interface modules and also the client program. The external CICS interface modules are supplied in CICSTS55.CICS.SDFHEXCI, which contains the following:

```

DFH$ATCC
DFH$AXCC
DFH$AXNC
DFH$DXVC
DFHMEBMX
DFHMET4E
DFHXCEIX
DFHXCIE (alias of DFHXCSTB)
DFHXCIS (alias of DFHXCSTB)
DFHXCOPT
DFHXCPRX
DFHXCSTB
DFHXCTRA
DFHXCURM

```

- You are recommended to include a DD statement for SYSMDUMP. The external CICS interface uses SYSMDUMP for some error conditions.
- The **REGION** parameter must specify a large enough region size to allow for the size of the internal trace table specified by the **TRACESZE** parameter in the DFHXCSTB options table.
- If the EXCI client program uses channels and containers, instead of a COMMAREA, to pass data to CICS, the **MEMLIMIT** parameter must be specified as container data is stored in 64-bit storage above the bar. Storage for containers cannot exceed 5% of the **MEMLIMIT** value.
- Include a SYSPRINT or equivalent DD statement for any output from the client program.

## Sample job for starting an EXCI client program

Figure 8 on page 58 shows a sample job that you can use or modify to start a client program.

```

//EXCI JOB (accounting_information),CLASS=A,TIME=1440,
// USER=userid,PASSWORD=pswd,REGION=100M
//*=====
//* JCL to execute an external CICS interface client program *
//*=====
//EXEC PGM=pgmname,REGION=nnM,MEMLIMIT=nnG
//STEPLIB DD DSN=CICSTS55.CICS.EXCI.LOADLIB,DISP=SHR
// DD DSN=CICSTS55.CICS.SDFHEXCI,DISP=SHR
//SYSPRINT DD SYSOUT=A
//SYSMDUMP DD DSN=SYS1.SYSMDP00,VOL=SER=valid,SPACE=(CYL,(1,1)),
// DISP=OLD,UNIT=3390

```

Figure 8. Sample job for starting an EXCI client program

### Note:

1. The job user ID, specified on the **USER** parameter, must be defined to RACF, or an equivalent external security manager (ESM).
2. In addition to being used for job step initiation security, the job user ID is also used for MRO logon and bind-time security checking.

See [EXCI security](#) for information about security when using the external CICS interface.

3. See [Setting up the EXCI sample programs](#) for information about modifying the sample connection definitions before you run the sample application programs in an environment that does not have RACF, or an equivalent external security manager (ESM), installed and active.

## CICS-supplied procedures for the EXCI

CICS provides nine procedures you can use to translate, compile, and link-edit your client programs.

One assembler procedure is provided. For the high-level languages, a variant that uses the stand-alone translator and one that uses the integrated translator is provided, as shown in the following list:

### **DFHEXTAL**

The assembler procedure for assembler versions of client programs and that use the stand-alone translator.

### **DFHYXTDL**

The procedure for C versions of client programs that are running under Language Environment® and using the stand-alone translator.

### **DFHYXTEL**

The procedure for C++ versions of client programs that are running under Language Environment and using the stand-alone translator.

### **DFHYXTPL**

The procedure for PL/I versions of client programs that are running under Language Environment and using the stand-alone translator.

### **DFHYXTVL**

The procedure for COBOL versions of client programs that are running under Language Environment and using the stand-alone translator.

### **DFHZXTCL**

The procedure for COBOL versions of client programs that are running under Language Environment and using the integrated translator.

### **DFHZXTDL**

The procedure for C versions of client programs that are running under Language Environment and using the integrated translator.

### **DFHZXTEL**

The procedure for C++ versions of client programs that are running under Language Environment and using the integrated translator.

### **DFHZXTPL**

The procedure for PL/I versions of client programs that are running under Language Environment and using the integrated translator.

To ensure that the EXCI stub is included with your client program, all these procedures include a step, COPYLINK, that unloads the stub into a temporary data set defined with a block length suitable for the linkage-editor. This temporary data set is then concatenated with the temporary data set containing your object program on the SYSLIN DD statement in the LKED step.

These procedures are supplied in the CICSTS55 .CICS.SDFHPROC library. You are recommended to copy them to SYS1.PROCLIB or another suitable procedure library.

## EXCI programming considerations

There are some language requirements that apply to writing an MVS client program that uses the external CICS interface. These affect programs written in PL/I and C. Also, for all languages, consider how you handle return codes before terminating your MVS client program.

### PL/I considerations

PL/I programs written to the external CICS interface must provide their parameters on the CALL to DFHXCIS in the form of an assembler-style parameter list.

The EXCI copybook for PL/I, DFHXCPLL, contains the necessary definition of the DFHXCIS entry point, as follows:

```
DCL DFHXCIS ENTRY OPTIONS(INTER ASSEMBLER);
```

The same rule applies for the EXCI LINK command, and in this case the CICS translator ensures that the correct parameter list is built.

For an example of an EXCI client program written in PL/I, see the source of the sample program, DFH\$PXCC.

## C considerations

C programs written to the external CICS interface must provide their parameters on the CALL to DFHXCIS in the form of an assembler-style parameter list. You ensure this by declaring the entry point to DFHXCIS with OS LINKAGE.

The EXCI copybook for C, DFHXCPLH, contains the necessary definition of the DFHXCIS entry point, as follows:

```
#pragma linkage(dfhxcis,OS)
```

The same rule applies for the EXCI LINK command, and in this case the CICS translator ensures that the correct parameter list is built.

For an example of an EXCI client program written in C, see the source of the sample program, DFH\$DXCC.

## Setting the return code (R15) at termination

The external CICS interface does not clear register 15 at termination, regardless of whether your client program executes normally or not. Therefore, even if your MVS client program terminates normally after successfully using the external CICS interface, the job step could end with an undefined return code.

To ensure a meaningful return code is given at termination, set the job step return code before terminating your program. The sample client programs illustrate how you can do this, using the saved response code from last call to the external CICS interface. For example, the COBOL sample DFH0CXCC program moves SAVED-RESPONSE to special register RETURN-CODE before terminating.

---

## Chapter 3. Configuring EXCI

The external CICS interface (EXCI) is an application programming interface that enables a non-CICS program (a client program) running in MVS to call a program (a server program) running in a CICS region and to pass and receive data by using a communications area or by using a channel and a set of containers. This section provides instructions for configuring EXCI.

### Setting up EXCI for static routing

---

You can statically route requests to CICS programs from applications that use the EXCI.

#### Before you begin

Before you begin, verify that the MVS parameter **Maxmember** is set to a high value. This parameter controls how many connections can be made to the DFHIRP00 resource.

#### Procedure

1. Add RDO group EXCIXXXX to the grouplist of the CICS region. If EXCIXXXX is not available, make a copy from the supplied DFH\$EXCI RDO group.  
This group contains all connections required for EXCI functions and can support up to 100 connections for batch requests.
2. Add the RDO group for the application to the grouplist of the CICS region.
3. Assemble DFHXCOPT into the SDFHEXCI load library. Ensure that DFHXCOPT has SURROGATE=YES.
4. Assemble and compile your application programs.  
If your application program is written in Assembler, use the linkage editor parameters AMODE(31) and RMODE(ANY). Link the program into your application load library.
5. Configure the batch JCL to run your application program.
  - a) Edit the JCL to specify to which CICS region the batch program will send the EXCI request:

```
//step0010 EXEC PGM=program,PARM='applid,userid'
```

*applid* is the CICS region and *userid* is a RACF user ID.

- b) Ensure your load library is concatenated as follows:

```
//STELIB DD Disp=shr,Dsn=SYS5C.CICn.CICS720.SDFHEXCI  
//DD Disp=shr,Dsn=Your.application.loadlib
```

6. Run the batch program and check that the results are as expected.

### Setting up EXCI for dynamic routing

---

You can dynamically route requests to CICS programs from applications that use the EXCI using CICSplex® SM.

#### About this task

#### Procedure

1. Specify the following system initialization parameters in the CICS region:
  - DSRTPGM=EYU9XLOP
  - DTRPGM=EYU9XLOP
2. Update your RDO group as follows:

a) Add an RDO entry for the EXCI server program, DFHMIRS.

You can use another transaction instead of EXCI if required, but it must point to program DFHMIRS and have a profile of DFHCICSA. Model it after the EXCI transaction in group DFH\$EXCI. This transaction will point to DFHMIRS program.

**Note:** The user transaction when defined as remote will only work within an APPC configuration. Within an EXCI or MRO configuration the mirror transaction must run in the local CICS region, by specifying DYNAMIC(NO) and no REMOTE attributes. Routing the mirror transaction to another CICS region can impact performance and make problem determination more difficult.

b) Add the RDO group to the terminal-owning region (TOR) LIST.

Ensure that the TOR region has program autoinstall disabled.

3. Log into CICSplex SM and define the transaction for the routing region into these CPSM groups: TXNGRP, WLMDEF, WLMGRP WLMSPEC.

4. For each application-owning region (AOR), create the RDO group in the same way as the sample definition DFH\$EXCI.

This group must contain only the connections, sessions, and application programs, or equivalent transactions. If you used a different transaction instead of EXCI, you must specify it in this group.

## Results

When an application issues a distributed program link, CICSplex SM checks if the incoming transaction is under its control. When it finds that EXCI or its equivalent is valid in its transaction group, CICSplex SM routes the transaction to one of the candidate AORs for processing.

An alternative to this approach is to define an RDO definition for the program or transaction with DYNAMIC=Yes. CICSplex SM routes the request to the selected region.

## Defining connections to CICS

---

Connections between an EXCI client program and a CICS region require connection definitions in the CICS region. You define these using the CONNECTION and the SESSIONS resource definition facilities provided by CICS.

The following options are provided specifically for the external CICS interface:

- CONNTYPE on the CONNECTION resource definition
- EXCI on the PROTOCOL attribute of the CONNECTION and SESSIONS resource definitions.

## CONNECTION resource definition for EXCI

The EXCI option is provided on the PROTOCOL attribute of the CONNECTION resource definition to indicate that the connection is for use by an MVS program using the external CICS interface.

The CONNTYPE attribute is provided on the CONNECTION resource definition. For EXCI connections, this indicates whether the connection is generic or specific. It is not to be used for any protocol other than the external CICS interface.

The following parameters are relevant to EXCI:

### **CONNTYPE({SPECIFIC|GENERIC})**

For external CICS interface connections, indicates the nature of the connection.

#### **SPECIFIC**

The connection is for communication from a non-CICS client program to the CICS region, and is specific. A specific connection is an MRO link with one or more sessions dedicated to a single user in a client program.

**Note:** A *user* is a program that has issued an Initialize\_User request (or for which an Initialize\_User request has been issued), with a unique name per TCB. For example:

- A simple client program running under MVS can be a single user of the external CICS interface.

- A client program running under MVS can open several pipes and issue external CICS interface calls over them sequentially, on behalf of different vendor packages. In this case, from the viewpoint of the client program, each of the packages is a user, identified by a unique user name. Thus a single client program can operate on behalf of multiple users.
- A program running under MVS can attach several TCBs, under each of which a vendor package issues external CICS interface calls on its own behalf. Each package is a client program in its own right, and runs under its own TCB. Each is also a user, with a unique user name.

For a specific connection, NETNAME is mandatory.

### **GENERIC**

The connection is for communication from a non-CICS client program to the CICS system, and is generic. A generic connection is an MRO link with a number of sessions to be shared by multiple EXCI users. For a generic connection you cannot specify the NETNAME attribute.

**Note:** You must install only one generic EXCI connection in a CICS region.

### **NETNAME**

For an external CICS interface connection, NETNAME corresponds to the name of the user of a specific pipe, as specified on the *user\_name* parameter of an INITIALISE\_USER call.

For an external CICS interface specific pipe, you must specify a NETNAME.

For external CICS interface generic pipes, you must leave NETNAME blank.

### **PROTOCOL({APPC|LU61|EXCI|blank})**

The type of protocol that is to be used for the link.

#### **blank**

For MRO between CICS regions. You must leave the PROTOCOL blank for MRO, and on the SESSIONS definition you must specify LU6.1 as the PROTOCOL.

#### **APPC (LUTYPE6.2 protocol)**

Advanced program-to-program communication, or APPC protocol. This is the default value for ACCESSMETHOD(VTAM®). Specify this for CICS-CICS ISC.

**Note:** VTAM is now the z/OS Communications Server.

#### **LU61**

LUTYPE6.1 protocol. Specify this for CICS-CICS ISC or CICS-IMS ISC, but not for MRO.

#### **EXCI**

The external CICS interface. Specify this to indicate that this connection is for use by a non-CICS client program using the external CICS interface.

If you specify PROTOCOL(EXCI), you must also specify ACCESSMETHOD(IRC). EXCI is implemented in MRO using the CICS interregion communication program, DFHIRP, and cannot use MRO links that use MVS cross-memory services (XM). EXCI can use also XCF MRO links, which also work through DFHIRP.

## **SESSIONS resource definitions for EXCI connections**

You indicate on the PROTOCOL attribute of the SESSIONS resource definition whether the sessions allocated on the MRO connection are for use by the external CICS interface.

For full details of the SESSIONS resource definition, see [SESSIONS resources](#). The following parameters are relevant to EXCI:

### **PROTOCOL({APPC|LU61|EXCI})**

Indicates the type of protocol that is to be used for an intercommunication link (ISC or MRO).

#### **APPC (LUTYPE6.2)**

Advanced program-to-program communication (APPC) protocol. Specify this for CICS-CICS ISC.

#### **LU61**

LUTYPE6.1 protocol. Specify this for CICS-CICS ISC, for CICS-IMS, or for MRO.

## **EXCI**

The external CICS interface. Specify this to indicate that the sessions are for use by a non-CICS client program using the external CICS interface. If you specify EXCI, you must leave SENDCOUNT blank.

## **RECEIVECOUNT({blank|*number*})**

The number of MRO, LUTYPE6.1, or EXCI sessions that usually receive before sending.

For MRO, receive sessions can only receive before sending.

### **blank**

These sessions can send only; there are no receive sessions.

### ***number***

Specifies the number of receive sessions on connections that specify blank, LU61, or EXCI on the protocol parameter of the CONNECTION definition. CICS uses the number to generate the last two or three characters of the session names (see RECEIVEPFX for details).

If you are using the default receive prefix (<), or your own 1-character prefix, specify a number in the range 1 through 999.

If you specify a 2-character prefix, the number is restricted to the range 1 through 99.

Except for external CICS interface (EXCI) connections, the RECEIVECOUNT in this system should equal SENDCOUNT in the other system.

## **RECEIVEPFX(<|*prefix*)**

Specifies a 1- or 2-character prefix that CICS is to use as the first 1 or 2 characters of the receive session names (the names of the terminal control table terminal entries (TCTTEs) for the sessions).

Prefixes must not cause a conflict with an existing connection or terminal name.

### **< (MRO and EXCI sessions)**

For MRO sessions, if you do not specify your own receive prefix, CICS enforces the default prefix—the less-than symbol (<), which is used in conjunction with the receive count to generate receive session names.

CICS creates the last three characters of the session names from the alphanumeric characters A through Z, and 1 through 9. These 3-character identifiers begin with the letters AAA, and continue in ascending sequence until the number of session entries reaches the limit set by the RECEIVECOUNT value. Note that receive session names are generated *after* the send sessions, and they follow in the same sequence.

For example, if the last session name generated for the send sessions is <AAJ, using the default prefix (<) CICS generates the receive session names as <AAK, <AAL, <AAM, and so on. (This method of generation of session identifiers is the same as for APPC sessions, except for the initial prefix symbol.)

**Note:** If you specify your own prefix, CICS generates the session names as in earlier releases, which is the same as for LUTYPE6.1 sessions.

### ***prefix* (LUTYPE6.1 sessions)**

If the sessions are on LUTYPE6.1 ISC connections, you must specify a 1- or 2-character prefix. Do not use the default < symbol for LUTYPE6.1 sessions.

For LUTYPE6.1 sessions (and MRO if you specify your own 1- or 2-character prefix) CICS generates session names by appending a number to the prefix, either in the range 1 through 99, or 1 through 999. The number begins with 1 and is incremented by 1 until the specified RECEIVECOUNT is reached.

## **SENDCOUNT(blank|*number*)**

The number of MRO or LUTYPE6.1 sessions that usually send before receiving.

For MRO, send sessions must send before they can receive.

### **blank**

These sessions can receive only; there are no send sessions.



You must leave this field blank when the sessions are on an external CICS interface (EXCI) connection.

**number**

Specifies the number of send sessions on connections that specify blank or LU61 on the protocol parameter of the CONNECTION definition. CICS uses the number to generate the last two or three characters of the session names (see SENDPFX for details).

If you are using the default send prefix (>), or your own 1-character prefix, specify a number in the range 1 through 999.

If you specify a 2-character prefix, the number is restricted to the range 1 through 99.

Except for external CICS interface (EXCI) connections the SENDCOUNT in the sending system should equal RECEIVECOUNT in the receiving system.

**SENDPFX(>|prefix)**

Specifies a 1- or 2-character prefix that CICS is to use as the first 1 or 2 characters of the send session names (the names of the terminal control table terminal entries (TCTTEs) for the sessions).

Prefixes must not cause a conflict with an existing connection or terminal name.

**> (MRO sessions)**

For MRO sessions, if you do not specify your own send prefix, CICS enforces the default prefix—the greater-than symbol (>), which is used in conjunction with the send count to generate send session names.

CICS creates the last three characters of the session names from the alphanumeric characters A through Z, and 1 through 9. These 3-character identifiers begin with the letters AAA, and continue in ascending sequence until the number of session entries reaches the limit set by the SENDCOUNT value.

For example, using the default prefix (>) CICS generates session names as >AAA, >AAB, >AAC, and so on. (This method of generation of session identifiers is the same as for APPC sessions, except for the initial symbol.)

**Note:** If you specify your own prefix, CICS generates the session names as in earlier releases, which is the same as for LUTYPE6.1 sessions.

**prefix (for LUTYPE6.1 sessions)**

If the sessions are on LUTYPE6.1 ISC connections, you must specify a 1- or 2-character prefix. Do not use the default > symbol for LUTYPE6.1 sessions.

For LUTYPE6.1 sessions (and MRO if you specify your own 1- or 2-character prefix) CICS generates session names by appending a number to the prefix, either in the range 1 through 99, or 1 through 999. The number begins with 1 and is incremented by 1 until the specified SENDCOUNT is reached.

**USERID(userid)**

The preset user identifier to be used for link security checking.

If you do not specify a preset userid for link security, CICS uses the userid passed from the remote user as the userid for link security. For an external CICS interface link, this is the client userid.

## Inquiring on the state of EXCI connections

If you have access, through a CICS terminal, to the CICS server region, you can inquire about batch jobs that are running a client application program, and which are using the external CICS interface to link to a server program in CICS.

### About this task

To obtain this information about batch jobs linked to CICS through MRO, you use the CEMT INQUIRE EXCI command. This command enables you to identify the names of external CICS interface batch jobs currently connected to CICS through the interregion communication (IRC) facility.

CICS returns job identifications in the form:

```
jobname.stepname.procname - mvsid
```

Either `stepname`, or `procname`, or both may not be present, indicated by the periods (.) being adjacent to one another.

The `mvsid` identifies the MVS system on which the job is running. If XCF/MRO is in use, the job can reside on a different MVS image from that on which CICS is running.

Information about jobs using the external CICS interface is available only when the job has issued at least one DPL request. A non-zero task number indicates that a DPL request is currently active. A zero task number indicates an external CICS interface session is still open (connected) for that job, although no DPL request is currently active.

See [CEMT - main terminal](#) for more information about the CEMT command.

## The EXCI user-replaceable module

The external CICS interface provides a user-replaceable module, DFHXCURM.

The load module is supplied in `CICSTS55.CICS.SDFHEXCI`, and the source in `CICSTS55.CICS.SDFHSAMP`. You can find information about assembling and link-editing user-replaceable programs in [Assembling and link-editing user-replaceable programs](#).

DFHXCURM is started by the external CICS interface in the non-CICS region during the processing of **allocate\_pipe** commands, and after the occurrence of any retryable error.

The retryable responses are:

- The target CICS region is not available.
- There are no pipes available on the target CICS region.
- There has been no IRC activity since the MVS IPL.

To retry after a retryable error, issue the EXCI call again.

As supplied, DFHXCURM is effectively a dummy program because of a branch instruction that bypasses the sample logic and returns control to the external CICS interface caller. To use the sample logic, remove the branch instruction and assemble and link edit the module. You can customize DFHXCURM to do the following actions:

- During `allocate_pipe` processing, you can change the specified CICS APPLID, to route the request to another CICS system.
- During `allocate_pipe` processing, you can direct the request to a different XCF group.
- When DFHXCURM is started after an error that can be tried again, you can store information about CICS availability. You can then use this information on the next invocation of DFHXCURM for `allocate_pipe` processing, so that you can decide which CICS system to route the request.

DFHXCURM is called using standard MVS register conventions, with register 1 containing the address of the parameter list, and register 14 the return address of the caller. The parameters addressed by register 1 are mapped in the EXCI\_URM\_PARMs DSECT, which is contained within the DFHXCPLD copybook. The parameters passed to DFHXCURM are as follows:

### URMINV

The address of a fullword that contains the reason for the invocation of DFHXCURM, defined by the following equates:

```
URM_ALLOCATE      EQU 1  This invocation is for an Allocate_Pipe
URM_NO_CICS       EQU 2  The target CICS region is not available
URM_NO_PIPE       EQU 3  There are no pipes available
URM_NO_CICS_IRC   EQU 4  There has been no IRC activity since the MVS IPL
```

## URMCICS

The address of an 8-byte area that contains the APPLID of the target CICS system, as specified on the **CICS\_applid** parameter of the **Allocate\_Pipe** command, or on the **APPLID** parameter of the **EXEC CICS LINK** command.

When specified by one of these commands, you can change the APPLID to that of a different target CICS region. Also, if the APPLID specified by one of these commands is not a valid specific applid, you must change the APPLID to that of a valid specific applid.

If the **CICS\_applid** parameter is omitted from the `allocate_pipe` request, or APPLID is omitted from the **EXEC CICS LINK** command, the field addressed by this parameter contains 8 blanks. In this case, you must specify an APPLID in DFHXCURM before returning control to the caller.

## URMAPPL

The address of an 8-byte area that contains the client program's user name as specified on the *my\_name* parameter of the `Initialize_User` command. If DFHXCURM is started for an EXEC CICS LINK command, this name is always set to DFHXCEIP.

## URMPROG

The address of an 8-byte area that contains the name of the target program (if available). This name is available only if DFHXCURM is started for an EXEC CICS LINK command. For an external CICS interface `allocate_pipe` command, the program name is not known until the DPL call is issued.

## URMOPTS

The address of a 1-byte area that contains the allocate options, which can be X'00' or X'80', as specified on the *allocate\_opts* parameter. This address is valid for an `Allocate_Pipe` request only.

## URMANCH

The address of a 4-byte area that is provided for use by DFHXCURM only. A typical use for this is to store a global anchor address of an area used to save information across a number of invocations of DFHXCURM. For example, you can GETMAIN the necessary storage and save the address in the 4-byte area addressed by this parameter. The initial value of the 4-byte area is set to zero.

There is one URMANCH parameter for each TCB in the address space using EXCI.

## URMXCFG

The address of an 8-byte area that contains the XCF group name as specified in the **XCFGROUP** parameter of the DFHXCOPT table. Use this parameter to change the XCF group name when DFHXCURM is called during the processing of EXCI `Allocate_Pipe` commands. If the call to DFHXCURM failed but can be tried again, the area contains the value used when previously allocating the pipe. Changing the value has no affect.

The group name must be 8 characters long, padded on the right with blanks if necessary. Valid characters are A-Z 0-9 \$ # @. Do not begin group names with the letters A, B, C, E, F, G, H, I "SYS." These names are used by IBM for its XCF groups. Also, do not use the name "UNDESIG", which is reserved for use by the system programmer in your installation.

It is advisable to use a group name beginning with the letters "DFHIR".

## Using the EXCI options table, DFHXCOPT

---

The EXCI options table, which is generated by the DFHXCOPT macro, enables you to specify a number of parameters that are required by the external CICS interface.

### DFHXCOPT options table: New format versus older format

The DFHXCOPT options table changed since it was first introduced and now includes a version number to allow more flexibility for future extensions. You need to be aware of this change if, for example, you plan to migrate a customized DFHXCOPT table from an earlier release of CICS.

To distinguish between the old and newer formats, the new-format table is link-edited with an alias called "DFHXCOPE". The following sequence is used to load the options table:

1. CICS tries to load the DFHXCOPT table using its alias name of DFHXCOPE. If it finds and successfully loads a load module named DFHXCOPE, CICS assumes that the table is in the new format.
2. If CICS does not find a load module named DFHXCOPE (or finds it but fails to load it), it tries to load the table using its "base" name of DFHXCOPT. In this case, CICS assumes that the table is in the older format.

CICS provides a default DFHXCOPT table and supplies the source code of the default table in the CICSTS55.CICS.SDFHSAMP library. The load module of the default DFHXCOPT table, with its alias DFHXCOPE, is in the CICSTS55.CICS.SDFHEXCI library.

## Creating customized DFHXCOPT table

You can tailor the source code of the CICS-supplied default DFHXCOPT table to your own requirements.

You must assemble and link-edit your customized DFHXCOPT table into a suitable library in the STEPLIB concatenation of the job that runs the MVS client program.

**Important: If you create your own, customized, DFHXCOPT table, ensure that you link-edit it using the DFHXCOPE alias.** Using the standard DFHAUPLE procedure ensures that this happens. If you reassemble and link-edit your table without the alias, CICS will load the default table (found by means of its DFHXCOPE alias), rather than your customized table.

You can use your own version of the CICS DFHAUPLE procedure to do this. The DFHAUPLE procedure is supplied in CICSTS55.CICS.SDFHINST.

## DFHXCOPT macro: Format and parameters

Unlike the tables you specify for CICS regions, the DFHXCOPT table cannot be suffixed.

The following table shows the format of the DFHXCOPT macro and its parameters.

DFHXCO	TYPE={ <b>CSECT</b>  DSECT} [,ABENDBKOUT={ <b>NO</b>  YES}] [,CICSSVC={ <b>216</b>  number}] [,CONFDATA={ <b>SHOW</b>  HIDETC}] [,DURETRY={ <b>30</b>  number-of-seconds}] [,GTF={ <b>OFF</b>  ON}] [,LOCALCCSID={ <b>037</b>  CCSID}] [,MSGCASE={ <b>MIXED</b>  UPPER}] [,TIMEOUT={ <b>0</b>  number}] [,TRACE={ <b>OFF</b>  1 2 3}] [,TRACESZE={ <b>16</b>  number-of-kilobytes}] [,TRAP={ <b>OFF</b>  ON}] [,XCFGROUP={ <b>DFHIR000</b>  name}]
	You must terminate your parameters with the following END statement.
END	DFHXCOPT

**TYPE={CSECT|DSECT}**

Indicates the type of table to be generated.

**CSECT**

A regular control section that is normally used.

**DSECT**

A dummy control section.

**ABENDBKOUT={NO|YES}**

Specifies whether a task that abends within the CICS server is to trigger an automatic rollback of the global unit of work. A global unit of work exists when an EXCI client program is controlling resource recovery through MVS RRS (that is, SYNCONRETURN is *not* specified on the DPL request). In this case you may well want the global unit of work to be marked for rollback if the CICS server program abends.

**Note:** ABENDBKOUT has no effect when SYNCONRETURN is specified on the DPL request.

**NO**

The global unit of work is not marked for rollback.

**YES**

When processing the abend of the server program, the CICS mirror program marks the global unit of work for backout.

In both cases the EXCI client program receives a return code of 422, SERVER\_ABENDED, on the EXCI DPL request.

**CICSSVC={216|number}**

Specifies the CICS type 3 SVC number being used for MRO communication. The default is 216.

The external CICS interface must use the same SVC number that is in use by the CICS MRO regions that reside in the MVS image in which the client program is running.

**0**

Specify zero to indicate that the external CICS interface is to obtain the CICS SVC number from MVS by means of an MVS VERIFY command.

You should only specify zero when you are sure that at least one CICS region has logged on to DFHIRP during the life of the MVS IPL.

**number**

Specify the CICS SVC number, in the range 200–255, that is in use for CICS interregion communications. This must be the SVC number that is installed in the MVS image in which the client program is running (the local MVS).

If no MRO CICS regions have ever logged on to DFHIRP in the local MVS during the life of the IPL, you must specify a non-zero SVC number. If you specify zero, the external CICS interface requests the SVC from MVS, which will fail if no CICS region has logged on to DFHIRP.

A non-zero value is required in those MVS images that do not run any CICS regions, and the client program is issuing DPL requests to a server CICS region that resides in another MVS. In these circumstances, the client program logs on to the local DFHIRP using the locally defined SVC, and communicates with the remote CICS region using XCF/MRO.

**Note:** All CICS regions using MRO within the same MVS image must use the highest level of both DFHIRP and the CICS SVC, DFHCSVC. If your MRO CICSplex consists of CICS regions at different release levels, the DFHIRP and DFHCSVC installed in the LPA must be from the highest release level of CICS within the CICSplex.

**CONFDATA={SHOW|HIDETC}**

Code this parameter to indicate whether the external CICS interface is to suppress (hide) user data that might otherwise appear in EXCI trace entries output to GTF or in EXCI dumps. This option applies to the tracing of the COMMAREA flowing between the EXCI client program and the CICS server program.

**SHOW**

Data suppression is not in effect. User data is traced.

**HIDETC**

EXCI is to 'hide' user COMMAREA data from trace entries. Instead of the COMMAREA data, the trace entry contains a character string stating that the data has been suppressed.

**DURETRY={30|number-of-seconds|0}**

Specifies the total time, in seconds, that the external CICS interface is to continue trying to obtain an MVS system dump using the SDUMP macro.

DURETRY allows you to control whether, and for how long, the external CICS interface is to reissue the SDUMP if another address space in the same MVS system is already taking an SDUMP when the external CICS interface issues an SDUMP request.

In the event of an SDUMP failure, the external CICS interface reacts as follows:

- If MVS is already taking an SDUMP for another address space, and the DURETRY parameter is nonzero, the external CICS interface issues an MVS STIMERM macro to wait for five seconds, before retrying the SDUMP macro. The external CICS interface issues a message to say that it will retry the SDUMP every five seconds until the DURETRY time limit.
- If the SDUMP fails for any other reason such as the following, the external CICS interface issues a message to inform you that the SDUMP has failed, giving the reason why.
  - There are no SYS1.DUMP data sets available.
  - There are I/O errors preventing completion of the dump.
  - The DURETRY limit expires while retrying SDUMP.

**30**

30 seconds allows the external CICS interface to retry up to six times (once every five seconds).

**number-of-seconds**

Code the total number of seconds (up to 32767 seconds) during which you want the external CICS interface to continue retrying the SDUMP macro. The external CICS interface retries the SDUMP, once every five seconds, until successful or until retries have been made over a period equal to or greater than the DURETRY value.

**0**

Code a zero value if you do not want CICS to retry the SDUMP.

**GTF={OFF|ON}**

Specifies whether all trace entries normally written to the external CICS interface trace table are also to be written to an MVS generalized trace facility (GTF) data set (if GTF tracing is active).

**OFF**

Code this if trace entries are not to be written to GTF.

**ON**

Code this if trace entries are to be written to GTF.

**LOCALCCSID={037|CCSID}**

Specifies the default CCSID for the EXCI job. The CCSID is a value of up to 8 characters. If a CCSID value is not specified, the default LOCALCCSID is set to 037. For lists of valid CCSIDs, see the following information:

- [CICS-supported conversions](#)
- The relevant appendix in [z/OS Unicode Services User's Guide and Reference](#)

**037**

The default value for LOCALCCSID.

**CCSID**

Represents any other valid EBCDIC CCSID value.

**MSGCASE={MIXED|UPPER}**

Specifies whether the DFHEXxxxx messages are to be issued in mixed case or in uppercase.

**MIXED**

Code this if messages are to be issued in mixed case.

**UPPER**

Code this if messages are to be issued in uppercase.

**TIMEOUT={0|number}**

Specifies the time interval, in hundredths of a second, during which the external CICS interface waits for a DPL command to complete.

DPL commands can pass a channel and set of containers to CICS. Commands that pass this information can involve multiple flows of data up to CICS in order to construct the container data. The timeout interval starts when the last flow of data is sent to CICS, which completes the data and initiates the invocation of the CICS server program.

**0**

Specifies that you do not want any time limit applied, and that the external CICS interface is to wait indefinitely for a DPL command to complete.

**number**

Specifies the time interval, in hundredths of a second, that the external CICS interface is to wait for a DPL command to complete. The number represents hundredths of a second, from 1 up to a maximum of 2 147 483 647. For example:

**6000**

Represents a timeout value of one minute.

**30000**

Represents a timeout value of five minutes.

**60000**

Represents a timeout value of ten minutes.

**TRACE={OFF|1|2|3}**

Specifies whether you want internal tracing for the external CICS interface, and at what level.

**OFF**

Internal tracing for the external CICS interface is not required. However, even with normal tracing switched off, exception trace entries are always written to the external CICS interface trace table in the CICS region.

**1**

Exception and level-1 trace entries are written to the external CICS interface trace table.

**2**

Exception, level-1, and level-2 trace entries are written to the external CICS interface trace table.

**3**

Exception, level-1, level-2, and level-3 trace entries are written to the external CICS interface trace table.

**TRACESIZE={16|number-of-kilobytes}**

Specifies the size in kilobytes of the trace table that is used by the external CICS interface. This trace table is allocated in 31-bit storage (above the line) in the CICS region.

**16**

The default size of the trace table, and also the minimum size.

***number-of-kilobytes***

The number of kilobytes of storage to be allocated for the trace table, in the range 16 KB through 1 048 576 KB. Subpool 1 is used for the trace table storage, which exists for the duration of the job step TCB. The table is page-aligned and occupies a whole number of pages. If the value specified is not a multiple of the page size (4 KB), it is rounded up to the next multiple of 4 KB.

**TRAP={OFF|ON}**

Specifies whether the service trap module, DFHXCTRA, is to be used. DFHXCTRA is supplied as a user-replaceable module, in which IBM service personnel can add code to trap errors.

**OFF**

Code this if you do not want to use DFHXCTRA.

**ON**

Code this if you require DFHXCTRA.

**XCFGROUP={DFHIR000}name}**

Specifies the name of the cross-system coupling facility (XCF) group to be joined by this client program.

**Note:** XCF groups allow CICS regions in different MVS images within the same sysplex to communicate with each other across multi-region operation (MRO) connections. For introductory information about XCF/MRO, and instructions on how to set up XCF groups, see [Cross-system multiregion operation \(XCF/MRO\)](#).

Each client program can join a maximum of one XCF group.

**DFHIR000**

The default XCF group name.

**name**

The group name must be eight characters long, padded on the right with blanks if necessary. The valid characters are A-Z 0-9 and the national characters \$ # and @. To avoid using the names IBM uses for its XCF groups, do not begin group names with the letters A through C, E through I, or the character string "SYS". Also, do not use the name "UNDESIG", which is reserved for use by the system programmer in your installation.

It is recommended that you use a group name beginning with the letters "DFHIR".



---

## Chapter 4. Security for EXCI

CICS applies security checks in a number of ways against requests received from an MVS client program.

### Using MRO logon and bind-time security

---

DFHIRP, the CICS interregion communication program, performs two security checks against users that want to either log on to IRP (specific connections only), or connect to a CICS region (also referred to as bind-time security).

#### About this task

**Generic EXCI connections:** The discussion about logon security checking in this section applies only to EXCI connections that are defined as SPECIFIC. The MRO logon security check is not performed for generic connections.

The MVS client program is treated just the same as another CICS region as far as MRO logon and connect (bind-time) security checking is concerned. This means that when the client program logs on to the interregion communication program, IRP performs logon and bind-time security checks against the user ID under which the client program is running. In the remainder of this information, this user ID is called the user ID of the batch region.

To enable your client program to log on to IRP successfully, and to connect to the target server region, first ensure that you define the user ID of the batch region in a user profile to RACF. After you define the user ID of the batch region to RACF, you can then give the batch region the appropriate logon and bind-time authorizations.

#### Procedure

- Logon authorization

Authorize the user ID of the batch region to the DFHAPPL.*user\_name* RACF FACILITY class profile, with UPDATE authority. The *user\_name* part of the profile name is the user name defined on the INITIALIZE\_USER command.

Failure to authorize the user ID of the batch region to the DFHAPPL profile of the specific user ID logging on to IRP causes Allocate\_Pipe processing to fail with RESPONSE(SYSTEM\_ERROR) REASON(IRC\_LOGON\_FAILURE). The subreason field-1 for a logon security check failure returns decimal 204.

See [“Defining DFHAPPL FACILITY class profiles for an EXCI region”](#) on page 73 for information about FACILITY class profiles for an EXCI client program.

- Bind-time authorization

Authorize the user ID of the batch region to the DFHAPPL.*applid* RACF FACILITY class profile of the target CICS server region, with READ authority.

Failure to authorize the user ID of the batch region to the DFHAPPL.*applid* profile of the CICS server region causes Open\_Pipe processing to fail with RESPONSE(SYSTEM\_ERROR) REASON(IRC\_CONNECT\_FAILURE). The subreason field-1 for a bind-time security check failure returns decimal 176.

See [Bind security](#) for information about the MRO logon and bind-time security checks, and for examples of how to define the RACF DFHAPPL profiles.

### Defining DFHAPPL FACILITY class profiles for an EXCI region

Define the *user\_name* part of the DFHAPPL profile name as follows:

- For the EXCI CALL interface, the *user\_name* must be the name you specify on the *user\_name* parameter of the INITIALIZE\_USER command.

Define FACILITY class profiles, with appropriate authorizations, for each user name specified in a client program if the program has INITIALIZE\_USER commands for more than one user name.

For example, if the *user\_name* defined on an INITIALIZE\_USER command is DCEUSER1, define the DFHAPPL profile in the FACILITY class as follows:

```
RDEFINE FACILITY (DFHAPPL.DCEUSER1) UACC(NONE)
```

If the batch region's user ID is CLIENTA, authorize the batch region to log on to IRP as follows:

```
PERMIT DFHAPPL.DCEUSER1 CLASS(FACILITY) ID(CLIENTA)
ACCESS(UPDATE)
```

- For the EXEC CICS LINK command, the *user\_name* is preset by the external CICS interface as DFHXCEIP. This does not require authorization for IRP logon, because the EXEC CICS LINK interface uses a generic connection to which the logon security check does not apply.

## Link security

The target CICS server region performs link security checking against requests from the client program.

These security checks cover transaction attach security (when attaching the mirror transaction), and resource and command security checking within the server application program. The link user ID that CICS uses for these security checks is the batch region's user ID.

To ensure these link security checks do not cause security failures, you must ensure that the link user ID is authorized to the following resource profiles, as appropriate:

- The profile for the mirror transaction, either CSMI for the default, or the mirror transaction specified on the *transid* parameter. This is required for transaction attach security checking.
- The profiles for all the resources accessed by the CICS server application program—files, queues (transient data and temporary storage), programs, and so on. This is required for resource security checking.
- The CICS command profiles for the SPI commands issued by the CICS server application program—INQUIRE, SET, DISCARD and so on. This is required for command security checking.

See [Bind security](#) for information about MRO link security checking.

## User security

The target CICS server region performs user security checking against the user ID passed on a DPL\_Request call. User security checking is performed only when connections specify ATTACHSEC(IDENTIFY).

User security is performed in addition to any link security.

For user security, in addition to any authorizations you make for link security, you must also authorize the user ID specified on the DPL\_Request call.

Note that there is no provision for specifying a user ID on the EXEC CICS LINK command. In this case, the external CICS interface passes the batch region's user ID. User security checking is therefore performed against the batch region's user ID if the connection definition specifies ATTACHSEC(IDENTIFY).

**Note:** If your connection resource definitions for the external CICS interface specify ATTACHSEC(IDENTIFY), your server programs will fail with an ATCY abend if you run them in an environment that does not have RACF, or an equivalent external security manager (ESM), installed and active.

If you want to run external CICS interface server programs without any security active, you must specify ATTACHSEC(LOCAL).

## Surrogate user checking

---

A surrogate user check is performed to verify that the batch region's user ID is authorized to issue DPL calls for another user (that is, is authorized as a surrogate of the user ID specified on the DPL\_Request call).

EXCI client jobs are subject to surrogate user checking. You must authorize the batch region's user ID as a surrogate of the user ID specified on all DPL\_Request calls. This means the batch region's user ID must have READ access to a profile named *execution\_userid.DFHEXCI* in the SURROGAT general resource class (where *execution\_userid* is the user ID specified on the DPL call). For example, the following commands define a surrogate profile for a DPL user ID, and grant READ access to the EXCI batch region:

```
RDEFINE SURROGAT execution_userid.DFHEXCI UACC(NONE)
PERMIT execution_userid.DFHEXCI CLASS(SURROGAT) ID(batch_region_userid) ACCESS(READ)
```

If no user ID is specified on the DPL\_Request call, no surrogate user check is performed because the user ID on the DPL\_Request call defaults to the batch region's user ID. For this bypass of surrogate user checking to be successful, ensure that you have correctly omitted the user ID on the DPL\_Request call. See the example of EXCI CALLs with null parameters in [The EXCI CALL interface](#) for the correct way to specify a null pointer when omitting an EXCI call parameter.

If the batch region's user ID and the CICS region user ID are different, link security checking is enforced. With link security, a non-authenticated user ID passed on a DPL\_Request call cannot acquire more authority than that allowed by the link security check. It can acquire only the same, or less, authority than that allowed by the link security check.

For more information about CICS security, see [CICS security](#).



---

## Chapter 5. Troubleshooting EXCI

**Important:** This information contains Diagnosis, Modification or Tuning information.

The external CICS interface provides diagnostic information that you can use to help with problem determination.

CICS provides the following diagnostic information:

- Trace
- System dumps
- MVS 04xx abends for the external CICS interface
- The EXCI service trap, DFHXCTRA
- EXCI trace entry points

For details of the external CICS interface messages and abend codes, see [DFHEX messages](#) and [04xx \(external CICS interface\) abend codes](#).

---

### Trace

The external CICS interface writes trace data to two destinations: an internal trace table and an external MVS GTF data set. The internal trace table resides in the non-CICS MVS address space. Trace data is formatted and included in any dumps produced by the external CICS interface.

Trace entries are issued by the external CICS interface destined for the internal trace table, an MVS GTF data set, or both. They are listed in [“EXCI trace entry points”](#) on page 79.

To use GTF for external CICS interface tracing, GTF user tracing must be active, GTF must be started in the MVS image, and you must specify GTF=ON in the DFHXCOPT options table.

If you use GTF trace for both the CICS server region and the external CICS interface region, the trace entries are interleaved, which can help you with problem determination in the CICS–EXCI environment.

**Note:** The external CICS interface maintains a separate trace table for each user TCB in an external CICS interface application program.

The external CICS interface does not support any form of auxiliary trace.

### Formatting GTF trace

To format external CICS interface trace entries written to GTF, you can use the standard CICS DFHTR720 trace formatting routine.

To format external CICS interface trace entries you use the same FID and ID as for CICS (that is, FID=X'EF', and ID=X'F6C').

---

### Using System dumps

The external CICS interface produces MVS SYSMDUMPs for some error conditions and MVS SDUMPs for other, more serious conditions. These dumps contain all the external CICS interface control blocks, as well as trace entries.

### Formatting system dumps

You can use the CICS IPCS verb exit, DFHPD720, to format the system dumps.

The following keywords are available for use when formatting an external CICS interface dump using DFHPD720:

**KE**

Formats PSW and registers, and all external CICS interface control blocks.

**LD**

Formats a load map of where the external CICS interface modules are loaded in the address space, and gives their PTF level.

**MRO**

Formats the MRO control blocks for the external CICS interface address space, including common control blocks that reside in the MVS common service area (CSA). This option also formats some MRO blocks that reside in the CICS address space for pipes connected to CICS.

**PG**

Formats the PG control blocks for channels and containers.

**TR**

Formats the external CICS interface trace table. You can format the trace table in abbreviated and full forms (TR=1 gives you the abbreviated trace).

**SU**

Produces a dump summary.

## Multiple TCBs

If the external CICS interface takes a system dump when there is more than one TCB in use, it dumps only the control blocks and trace table for the TCB that requested the dump.

If you take a memory dump of the external CICS address space using a console command, the CICS verb exit routine, DFHPD720 formats the control blocks and trace tables for every TCB it finds in the dump.

## Capturing SYSDUMPs

To capture SYSDUMPs produced by the external CICS interface, ensure you always include a DD statement for the SYSDUMP data set in the client application program's JCL.

## Using the MVS DUMP command at the console for dumps

In addition to the dumps taken automatically by the external CICS interface, you can also force a dump of an address space running a client application program by entering the **MVS DUMP** command at the console.

You can use the CICS IPCS verb exit routine DFHPD720 to format dumps taken in this way. You can also issue the DUMP command from TSO, SDSF, or NetView®.

You can also use the **DUMP** command to dump the CICS server address space as well as the client address space. Use the CICS IPCS verb exit routine DFHPD720 to format the dump that contains both address spaces.

## The EXCI service trap, DFHXCTRA

---

A user-replaceable program, DFHXCTRA, is available for use under the guidance of IBM service personnel. It is the equivalent of DFHTRAP used in CICS. It is invoked every time the external CICS interface writes a trace entry.

DFHXCTRA can perform one or all of the following actions:

1. Request the external CICS interface to write a trace entry on its behalf
2. Instruct the external CICS interface to take an SDUMP
3. Instruct the external CICS interface to skip writing the current trace entry to GTF
4. Instruct the external CICS interface to disable DFHXCTRA

The CICS-supplied sample version of DFHXCTRA performs all four functions if it detects a trace entry that indicates that a FREEMAIN error occurred while trying to free an EXCI pipe control block.

The source for DFHXCTRA is supplied in CICSTS55.CICS.SDFHMAC. The parameter list passed to DFHXCTRA is defined in the copybook DFHXCTRD, which is supplied in CICSTS55.CICS.SDFHMAC.DFHXCTRD also defines all the external CICS interface trace points for use by DFHXCTRA.

## Problem determination with RRMS

When Recoverable Resource Management Services (RRMS) is used to coordinate DPL requests, you can obtain additional problem determination information from RRMS.

To do this, you can use ISPF dialogs, provided by Resource Recovery Services (RRS), as follows:

- You can browse the RRS log streams.
- You can display information about RRS resource managers.
- you can dsplay information about RRS Units of Recovery.

For information about how to install and use the dialogs, see [z/OS MVS Programming: Resource Recovery](#).

## EXCI trace entry points

Point ID	Module	Lvl	Type	Data
EX 0001	DFHXCPRH	Exc	PIPE_ALREADY_OPEN	<ol style="list-style-type: none"> <li>1. Caller's parameter list</li> <li>2. Call type</li> <li>3. Caller's user name</li> <li>4. Return codes and message pointer</li> <li>5. Pipe token</li> </ol>
EX 0002	DFHXCPRH	Exc	PIPE_ALREADY_CLOSED	<ol style="list-style-type: none"> <li>1. Caller's parameter list</li> <li>2. Call type</li> <li>3. Caller's user name</li> <li>4. Return codes and message pointer</li> <li>5. Pipe token</li> </ol>
EX 0003	DFHXCPRH	Exc	VERIFY_BLOCK_FM_ERROR	<ol style="list-style-type: none"> <li>1. Caller's parameter list</li> <li>2. Call type</li> <li>3. Caller's user name</li> <li>4. Return codes and message pointer</li> </ol>
EX 0005	DFHXCPRH	Exc	XCIPIP_FM_ERR	<ol style="list-style-type: none"> <li>1. Caller's parameter list</li> <li>2. Call type</li> <li>3. Caller's user name</li> <li>4. Return codes and message pointer</li> <li>5. Pipe token</li> </ol>
EX 0006	DFHXCPRH	Exc	IRP_IOAREA_FM_ERR	<ol style="list-style-type: none"> <li>1. Caller's parameter list</li> <li>2. Call type</li> <li>3. Caller's user name</li> <li>4. Return codes and message pointer</li> </ol>
EX 0008	DFHXCPRH	Exc	XFRSTG1_FM_ERR	<ol style="list-style-type: none"> <li>1. Caller's parameter list</li> <li>2. Call type</li> <li>3. Caller's user name</li> <li>4. Return codes and message pointer</li> <li>5. Pipe token</li> </ol>

Table 7. External CICS interface trace entries (continued)

Point ID	Module	Lvl	Type	Data
EX 0201	DFHXCPRH	Exc	NO_CICS_IRC_STARTED	<ol style="list-style-type: none"> <li>1. Caller's parameter list</li> <li>2. Call type</li> <li>3. Caller's user name</li> <li>4. Return codes and message pointer</li> </ol>
EX 0202	DFHXCPRH	Exc	NO_PIPE	<ol style="list-style-type: none"> <li>1. Caller's parameter list</li> <li>2. Call type</li> <li>3. Caller's user name</li> <li>4. Return codes and message pointer</li> <li>5. Pipe token</li> <li>6. Target CICS applid</li> </ol>
EX 0203	DFHXCPRH	Exc	NO_CICS_ON_OPEN	<ol style="list-style-type: none"> <li>1. Caller's parameter list</li> <li>2. Call type</li> <li>3. Caller's user name</li> <li>4. Return codes and message pointer</li> <li>5. Pipe token</li> <li>6. Target CICS applid</li> </ol>
EX 0204	DFHXCPRH	Exc	NO_CICS_ON_DPL_1	<ol style="list-style-type: none"> <li>1. Caller's parameter list</li> <li>2. Call type</li> <li>3. Caller's user name</li> <li>4. Return codes and message pointer</li> <li>5. Pipe token</li> <li>6. Target CICS applid</li> </ol>
EX 0205	DFHXCPRH	Exc	NO_CICS_ON_DPL_2	<ol style="list-style-type: none"> <li>1. Caller's parameter list</li> <li>2. Call type</li> <li>3. Caller's user name</li> <li>4. Return codes and message pointer</li> <li>5. Pipe token</li> <li>6. Target CICS applid</li> </ol>
EX 0206	DFHXCPRH	Exc	NO_CICS_ON_DPL_3	<ol style="list-style-type: none"> <li>1. Caller's parameter list</li> <li>2. Call type</li> <li>3. Caller's user name</li> <li>4. Return codes and message pointer</li> <li>5. Pipe token</li> <li>6. Target CICS applid</li> </ol>
EX 0301	DFHXCCH DFHXCCP DFHXCCR DFHXCNVG DFHXCSCR DFHXC64	EX 1	SMGF entry	<ol style="list-style-type: none"> <li>1. SMGF Plist</li> </ol>
EX 0302	DFHXCCH DFHXCCP DFHXCCR DFHXCNVG DFHXCSCR DFHXC64	EX 1	SMGF exit	<ol style="list-style-type: none"> <li>1. SMGF Plist</li> </ol>



Table 7. External CICS interface trace entries (continued)

Point ID	Module	Lvl	Type	Data
EX 0303	DFHXCCH DFHXCCP DFHXCCR DFHXCNVG DFHXCSCR DFHXC64	Exc	SMGF exception	1. MVS return code
EX 0403	DFHXCPRH	Exc	INVALID_APPL_NAME	1. Caller's parameter list 2. Call type 3. Caller's user name 4. Return codes and message pointer
EX 0405	DFHXCPRH	Exc	PIPE_NOT_CLOSED	1. Caller's parameter list 2. Call type 3. Caller's user name 4. Return codes and message pointer 5. Pipe token
EX 0406	DFHXCPRH	Exc	PIPE_NOT_OPEN	1. Caller's parameter list 2. Call type 3. Caller's user name 4. Return codes and message pointer 5. Pipe token
EX 0407	DFHXCPRH	Exc	INVALID_USERID	1. Caller's parameter list 2. Call type 3. Caller's user name
EX 0408	DFHXCPRH	Exc	INVALID_UOWID	1. Caller's parameter list 2. Call type 3. Caller's user name 4. UOWID
EX 0409	DFHXCPRH	Exc	INVALID_TRANSID	1. Caller's parameter list 2. Call type 3. Caller's user name
EX 0414	DFHXCPRH	Exc	ABORT_RECEIVED	1. Caller's parameter list 2. Call type 3. Caller's user name 4. Target CICS applid 5. Message to be returned
EX 0415	DFHXCPRH	Exc	INVALID_CONNECTION	1. Caller's parameter list 2. Call type 3. Caller's user name 4. Connection name 5. Target CICS applid
EX 0416	DFHXCPRH	Exc	INVALID_CICS_RELEASE	1. Caller's parameter list 2. Call type 3. Caller's user name 4. Target CICS applid
EX 0417	DFHXCPRH	Exc	PIPE_MUST_CLOSE	1. Caller's parameter list 2. Call type 3. Caller's user name 4. Pipe token

Table 7. External CICS interface trace entries (continued)

Point ID	Module	Lvl	Type	Data
EX 0418	DFHXCPRH	Exc	INVALID_PIPE_TOKEN	<ol style="list-style-type: none"> <li>1. Caller's parameter list</li> <li>2. Call type</li> <li>3. Caller's user name</li> <li>4. Pipe token</li> </ol>
EX 0422	DFHXCPRH	Exc	SERVER_ABENDED	<ol style="list-style-type: none"> <li>1. Caller's parameter list</li> <li>2. Call type</li> <li>3. Caller's user name</li> <li>4. Return codes and message pointer</li> <li>5. DPL return area</li> </ol>
EX 0423	DFHXCPRH	Exc	SURROGATE_CHECK_FAILED	<ol style="list-style-type: none"> <li>1. Caller's parameter list</li> <li>2. Call type</li> <li>3. Caller's user name</li> <li>4. Job user ID</li> <li>5. Surrogate resource name</li> <li>6. ESM return code and reason code</li> </ol>
EX 0426	DFHXCPRH	Exc	INVALID_TRANSID2	<ol style="list-style-type: none"> <li>1. Caller's parameter list</li> <li>2. Call type</li> <li>3. Caller's user name</li> </ol>
EX 0427	DFHXCPRH	Exc	INVALID_CCSID	<ol style="list-style-type: none"> <li>1. Caller's parameter list</li> <li>2. Call type</li> <li>3. Caller's user name</li> </ol>
EX 0428	DFHXCPRH	Exc	INVALID_ENDIAN	<ol style="list-style-type: none"> <li>1. Caller's parameter list</li> <li>2. Call type</li> <li>3. Caller's user name</li> </ol>
EX 0431	DFHXCPRH	Exc	COMMAREA_LEN_NOT_ALLOWED	<ol style="list-style-type: none"> <li>1. Caller's parameter list</li> <li>2. Call type</li> <li>3. Caller's user name</li> </ol>
EX 0432	DFHXCPRH	Exc	DATA_LEN_NOT_ALLOWED	<ol style="list-style-type: none"> <li>1. Caller's parameter list</li> <li>2. Call type</li> <li>3. Caller's user name</li> </ol>
EX 0433	DFHXCPRH	Exc	CCSID_NOT_ALLOWED	<ol style="list-style-type: none"> <li>1. Caller's parameter list</li> <li>2. Call type</li> <li>3. Caller's user name</li> </ol>
EX 0434	DFHXCPRH	Exc	ENDIAN_NOT_ALLOWED	<ol style="list-style-type: none"> <li>1. Caller's parameter list</li> <li>2. Call type</li> <li>3. Caller's user name</li> </ol>
EX 0603	DFHXCPRH	Exc	XCUSER_GM_ERROR	<ol style="list-style-type: none"> <li>1. Caller's parameter list</li> <li>2. Call type</li> <li>3. Caller's user name</li> <li>4. Return codes and message pointer</li> </ol>
EX 0604	DFHXCPRH	Exc	XCPIPE_GM_ERROR	<ol style="list-style-type: none"> <li>1. Caller's parameter list</li> <li>2. Call type</li> <li>3. Caller's user name</li> <li>4. Return codes and message pointer</li> </ol>

Table 7. External CICS interface trace entries (continued)

Point ID	Module	Lvl	Type	Data
EX 0605	DFHXCPRH	Exc	VERIFY_BLOCK_GM_ERROR	<ol style="list-style-type: none"> <li>1. Caller's parameter list</li> <li>2. Call type</li> <li>3. Caller's user name</li> <li>4. Return codes and message pointer</li> </ol>
EX 0606	DFHXCPRH	Exc	SSI_VERIFY_FAILED	<ol style="list-style-type: none"> <li>1. Caller's parameter list</li> <li>2. Call type</li> <li>3. Caller's user name</li> <li>4. Return codes and message pointer</li> </ol>
EX 0607	DFHXCPRH	Exc	SVC_CALL_FAILED	<ol style="list-style-type: none"> <li>1. Caller's parameter list</li> <li>2. Call type</li> <li>3. Caller's user name</li> <li>4. Return codes and message pointer</li> </ol>
EX 0608	DFHXCPRH	Exc	IRP_LOGON_FAILURE	<ol style="list-style-type: none"> <li>1. Caller's parameter list</li> <li>2. Call type</li> <li>3. Caller's user name</li> <li>4. Return codes and message pointer</li> <li>5. Target CICS applid</li> <li>6. Logon name</li> </ol>
EX 0609	DFHXCPRH	Exc	IRP_CONNECT_FAIL	<ol style="list-style-type: none"> <li>1. Caller's parameter list</li> <li>2. Call type</li> <li>3. Caller's user name</li> <li>4. Return codes and message pointer</li> <li>5. Pipe token</li> <li>6. Target CICS applid</li> </ol>
EX 0610	DFHXCPRH	Exc	IRP_DISC_FAIL	<ol style="list-style-type: none"> <li>1. Caller's parameter list</li> <li>2. Call type</li> <li>3. Caller's user name</li> <li>4. Return codes and message pointer</li> <li>5. Target CICS applid</li> <li>6. Pipe token</li> </ol>
EX 0611	DFHXCPRH	Exc	IRP_LOGOFF_FAILED	<ol style="list-style-type: none"> <li>1. Caller's parameter list</li> <li>2. Call type</li> <li>3. Caller's user name</li> <li>4. Return codes and message pointer</li> <li>5. Target CICS applid</li> <li>6. Pipe token</li> </ol>
EX 0612	DFHXCPRH	Exc	TRANSFORM_1_ERROR	<ol style="list-style-type: none"> <li>1. Caller's parameter list</li> <li>2. Call type</li> <li>3. Caller's user name</li> <li>4. Return codes and message pointer</li> </ol>
EX 0613	DFHXCPRH	Exc	TRANSFORM_4_ERROR	<ol style="list-style-type: none"> <li>1. Caller's parameter list</li> <li>2. Call type</li> <li>3. Caller's user name</li> <li>4. Return codes and message pointer</li> </ol>
EX 0614	DFHXCPRH	Exc	IRP_NULL_DATA	<ol style="list-style-type: none"> <li>1. Caller's parameter list</li> <li>2. Call type</li> <li>3. Caller's user name</li> <li>4. Return codes and message pointer</li> <li>5. Target CICS applid</li> </ol>

Table 7. External CICS interface trace entries (continued)

Point ID	Module	Lvl	Type	Data
EX 0615	DFHXCPRH	Exc	IRP_NEG_RESPONSE	<ol style="list-style-type: none"> <li>1. Caller's parameter list</li> <li>2. Call type</li> <li>3. Caller's user name</li> <li>4. Return codes and message pointer</li> <li>5. Target CICS applid</li> </ol>
EX 0616	DFHXCPRH	Exc	IRP_SWITCH_PULL_ERR	<ol style="list-style-type: none"> <li>1. Caller's parameter list</li> <li>2. Call type</li> <li>3. Caller's user name</li> <li>4. Return codes and message pointer</li> <li>5. Target CICS applid</li> <li>6. Pipe token</li> </ol>
EX 0617	DFHXCPRH	Exc	IRP_IOAREA_GM_ERR	<ol style="list-style-type: none"> <li>1. Caller's parameter list</li> <li>2. Call type</li> <li>3. Caller's user name</li> <li>4. Return codes and message pointer</li> </ol>
EX 0619	DFHXCPRH	Exc	IRP_BAD_IOAREA	<ol style="list-style-type: none"> <li>1. Caller's parameter list</li> <li>2. Call type</li> <li>3. Caller's user name</li> <li>4. IOAREA address</li> </ol>
EX 0620	DFHXCPRH	Exc	IRP_PROTOCOL_ERR	<ol style="list-style-type: none"> <li>1. Caller's parameter list</li> <li>2. Call type</li> <li>3. Caller's user name</li> <li>4. Target CICS applid</li> <li>5. Pipe token</li> </ol>
EX 0621	DFHXCPRH	Exc	PIPE_RECOVERY_FAILURE	<ol style="list-style-type: none"> <li>1. Caller's parameter list</li> <li>2. Call type</li> <li>3. Caller's user name</li> <li>4. Target CICS applid</li> <li>5. Pipe token</li> </ol>
EX 0622	DFHXCPRH	Exc	ESTAE_SETUP_FAIL	<ol style="list-style-type: none"> <li>1. Caller's parameter list</li> <li>2. Call type</li> <li>3. Caller's user name</li> <li>4. Return codes and message pointer</li> </ol>
EX 0623	DFHXCPRH	Exc	ESTAE_INVOKED	<ol style="list-style-type: none"> <li>1. Caller's parameter list</li> <li>2. Call type</li> <li>3. Caller's user name</li> <li>4. Return codes and message pointer</li> <li>5. MVS abend code</li> </ol>
EX 0624	DFHXCPRH	Exc	TIMEDOUT	<ol style="list-style-type: none"> <li>1. Caller's parameter list</li> <li>2. Call type</li> <li>3. Caller's user name</li> <li>4. Server program name</li> <li>5. Target CICS applid</li> </ol>
EX 0625	DFHXCPRH	Exc	STIMER_SETUP_FAIL	<ol style="list-style-type: none"> <li>1. Caller's parameter list</li> <li>2. Call type</li> <li>3. Caller's user name</li> <li>4. Return codes and message pointer</li> </ol>

Table 7. External CICS interface trace entries (continued)

Point ID	Module	Lvl	Type	Data
EX 0626	DFHXCPRH	Exc	STIMER_CANCEL_FAIL	<ol style="list-style-type: none"> <li>1. Caller's parameter list</li> <li>2. Call type</li> <li>3. Caller's user name</li> <li>4. Return codes and message pointer</li> </ol>
EX 0627	DFHXCPRH	Exc	INCORRECT_SVC_LEVEL	<ol style="list-style-type: none"> <li>1. Caller's parameter list</li> <li>2. Call type</li> <li>3. Caller's user name</li> <li>4. SVC instruction</li> </ol>
EX 0628	DFHXCPRH	Exc	INCORRECT_IRP_LVL	<ol style="list-style-type: none"> <li>1. Caller's parameter list</li> <li>2. Call type</li> <li>3. Caller's user name</li> <li>4. Return codes and message pointer</li> </ol>
EX 0629	DFHXCPRH	Exc	SERVER_PROTOCOL_ERR	<ol style="list-style-type: none"> <li>1. Caller's parameter list</li> <li>2. Call type</li> <li>3. Caller's user name</li> <li>4. Connection name</li> <li>5. CICS name</li> </ol>
EX 0633	DFHXCPRH	Exc	INQUIRE_CHANNEL_FAILED	<ol style="list-style-type: none"> <li>1. Caller's parameter list</li> <li>2. Call type</li> <li>3. Caller's user name</li> </ol>
EX 0800	DFHXCPRH	Exc	RESP shows LENGERR	<ol style="list-style-type: none"> <li>1. Caller's parameter list</li> <li>2. Call type</li> <li>3. Caller's user name</li> <li>4. Return codes and message pointer</li> <li>5. COMMAREA length</li> <li>6. Data length</li> </ol>
EX 0801	DFHXCPRH	Exc	RESP shows INVREQ	<ol style="list-style-type: none"> <li>1. Caller's parameter list</li> <li>2. Call type</li> <li>3. Caller's user name</li> <li>4. Return codes and message pointer</li> <li>5. DPL options specified</li> </ol>
EX 0802	DFHXCPRH	Exc	RESP shows PGMIDERR	<ol style="list-style-type: none"> <li>1. Caller's parameter list</li> <li>2. Call type</li> <li>3. Caller's user name</li> <li>4. Program name</li> <li>5. Target CICS applid</li> </ol>
EX 0803	DFHXCPRH	Exc	RESP shows ROLLEDBACK	<ol style="list-style-type: none"> <li>1. Caller's parameter list</li> <li>2. Call type</li> <li>3. Caller's user name</li> <li>4. Program name</li> <li>5. Target CICS applid</li> </ol>
EX 0804	DFHXCPRH	Exc	RESP shows NOTAUTH	<ol style="list-style-type: none"> <li>1. Caller's parameter list</li> <li>2. Call type</li> <li>3. Caller's user name</li> <li>4. Program name</li> <li>5. Target CICS applid</li> </ol>

Table 7. External CICS interface trace entries (continued)

Point ID	Module	Lvl	Type	Data
EX 0805	DFHXCPRH	Exc	RESP shows SYSIDERR	<ol style="list-style-type: none"> <li>1. Caller's parameter list</li> <li>2. Call type</li> <li>3. Caller's user name</li> <li>4. Program name</li> <li>5. Target CICS applid</li> <li>6. DPL_Retarea</li> </ol>
EX 0806	DFHXCPRH	Exc	RESP shows TERMERR	<ol style="list-style-type: none"> <li>1. Caller's parameter list</li> <li>2. Call type</li> <li>3. Caller's user name</li> <li>4. Program name</li> <li>5. Target CICS applid</li> </ol>
EX 0904	DFHXCTRP	Exc	Overlength trace data field	<ol style="list-style-type: none"> <li>1. XCTRP parameter list</li> </ol>
EX 0905	DFHXCTRA	Exc	DFHXCTRA trace entry	<ol style="list-style-type: none"> <li>1. User specified data</li> </ol>
EX 1000	DFHXCPRH	EX 1	Entry	<p>For INIT_USER commands:</p> <ol style="list-style-type: none"> <li>1. Caller's parameter list</li> <li>2. Call type</li> <li>3. Caller's user name</li> <li>4. Caller's register 14</li> </ol> <p>For Allocate_Pipe requests:</p> <ol style="list-style-type: none"> <li>1. Caller's parameter list</li> <li>2. Call type</li> <li>3. Caller's user name</li> <li>4. CICS name</li> <li>5. Allocate options</li> <li>6. Caller's register 14</li> </ol> <p>For Open, Close, and Deallocate requests:</p> <ol style="list-style-type: none"> <li>1. Caller's parameter list</li> <li>2. Call type</li> <li>3. Caller's user name</li> <li>4. CICS name</li> <li>5. Pipe token</li> <li>6. Caller's register 14</li> </ol> <p>For DPL requests:</p> <ol style="list-style-type: none"> <li>1. Caller's parameter list</li> <li>2. Call type</li> <li>3. Caller's user name</li> <li>4. CICS name</li> <li>5. Pipe token</li> <li>6. Program name</li> <li>7. Caller's register 14</li> </ol>

Table 7. External CICS interface trace entries (continued)

Point ID	Module	Lvl	Type	Data
EX 1001	DFHXCPRH	EX 1	Exit	<p>For INIT_USER, OPEN, CLOSE, and DEALLOCATE requests:</p> <ol style="list-style-type: none"> <li>1. Caller's parameter list</li> <li>2. Call type</li> <li>3. Caller's user name</li> <li>4. Return codes and message pointer</li> <li>5. Caller's register14</li> </ol> <p>For Allocate requests:</p> <ol style="list-style-type: none"> <li>1. Caller's parameter list</li> <li>2. Call type</li> <li>3. Caller's user name</li> <li>4. Return codes and message pointer</li> <li>5. Pipe token</li> <li>6. Caller's register 14</li> </ol> <p>For DPL requests:</p> <ol style="list-style-type: none"> <li>1. Caller's parameter list</li> <li>2. Call type</li> <li>3. Caller's user name</li> <li>4. Target CICS system</li> <li>5. Pipe token</li> </ol>
EX 1010	DFHXCEIP	EX 1	Entry	<ol style="list-style-type: none"> <li>1. Program name</li> <li>2. Target CICS applid</li> <li>3. Transaction ID</li> <li>4. Caller's register 14</li> <li>5. Up to the first 100 bytes of COMMAREA (if passed)</li> <li>6. COMMAREA length, if COMMAREA passed</li> <li>7. Data length, if COMMAREA passed</li> </ol>
EX 1011	DFHXCEIP	EX 1	Exit	<ol style="list-style-type: none"> <li>1. EXEC retarea</li> <li>2. Program name</li> <li>3. Target CICS applid</li> <li>4. Transaction ID</li> <li>5. Caller's register 14</li> <li>6. Up to the first 100 bytes of COMMAREA (if passed)</li> <li>7. COMMAREA length, if COMMAREA passed</li> </ol>
EX 1020	DFHXCEIP	EX 1	Entry2	<ol style="list-style-type: none"> <li>1. Program name</li> <li>2. Target CICS applid</li> <li>3. Transaction ID</li> <li>4. Caller's register 14</li> <li>5. Channel name</li> </ol>
EX 1021	DFHXCEIP	EX 1	Exit2	<ol style="list-style-type: none"> <li>1. Program name</li> <li>2. Target CICS applid</li> <li>3. Transaction ID</li> <li>4. Caller's register 14</li> <li>5. Channel name</li> </ol>
EX 1022	DFHXCEIP	EX 1	Entry3	<ol style="list-style-type: none"> <li>1. Caller's register 14</li> </ol>
EX 1023	DFHXCEIP	EX 1	Exit3	<ol style="list-style-type: none"> <li>1. Caller's register 14</li> </ol>

Table 7. External CICS interface trace entries (continued)

Point ID	Module	Lvl	Type	Data
EX 2000	DFHXCPRH	EX 2	IRP_LOGON	<ol style="list-style-type: none"> <li>1. Caller's parameter list</li> <li>2. Call type</li> <li>3. Caller's user name</li> <li>4. Target CICS applid</li> <li>5. IRP user ID</li> <li>6. SLCB address</li> <li>7. Connection name</li> </ol>
EX 2001	DFHXCPRH	EX 2	IRP_CONN	<ol style="list-style-type: none"> <li>1. Caller's parameter list</li> <li>2. Call type</li> <li>3. Caller's user name</li> <li>4. Target CICS applid</li> <li>5. IRP user ID</li> <li>6. IRP thread ID</li> <li>7. SCCB address</li> </ol>
EX 2002	DFHXCPRH	EX 2	IRP_DISC	<ol style="list-style-type: none"> <li>1. Caller's parameter list</li> <li>2. Call type</li> <li>3. Caller's user name</li> <li>4. Target CICS applid</li> <li>5. Pipe token</li> </ol>
EX 2003	DFHXCPRH	EX 2	IRP_LOGOFF	<ol style="list-style-type: none"> <li>1. Caller's parameter list</li> <li>2. Call type</li> <li>3. Caller's user name</li> <li>4. Pipe token</li> <li>5. IRP user ID</li> </ol>
EX 2004	DFHXCPRH	EX 2	IRP_SWITCH	<ol style="list-style-type: none"> <li>1. Caller's parameter list</li> <li>2. Call type</li> <li>3. Caller's user name</li> <li>4. Target CICS applid</li> <li>5. IRP user ID</li> <li>6. IRP user thread</li> </ol>
EX 2005	DFHXCPRH	EX 2	IRP_SWITCH_DATA	<ol style="list-style-type: none"> <li>1. User's appl name</li> <li>2. Pipe token</li> <li>3. Request header</li> <li>4. Bind data</li> <li>5. UOWID/USERID FMH</li> <li>6. Transformed DPL request to CICS (up to 1000 bytes)</li> <li>7. Final 1000 bytes of transformed DPL request</li> </ol>
EX 2006	DFHXCPRH	EX 2	IRP_DATA	<ol style="list-style-type: none"> <li>1. Caller's parameter list</li> <li>2. Call type</li> <li>3. Caller's user name</li> <li>4. Target CICS applid</li> <li>5. Length of data returned</li> <li>6. Data (first 1000 bytes)</li> <li>7. Data (final 1000 bytes)</li> </ol>



Table 7. External CICS interface trace entries (continued)

Point ID	Module	Lvl	Type	Data
EX 2007	DFHXCPRH	EX 2	PRE_URM	<ol style="list-style-type: none"> <li>1. Caller's parameter list</li> <li>2. Call type</li> <li>3. Caller's user name</li> <li>4. Parameters passed to DFHXCURM</li> <li>5. URMINV, reason for calling URM</li> <li>6. URMCIICS, target CICS applid</li> <li>7. URMANCH, URM anchor point address</li> </ol>
EX 2008	DFHXCPRH	EX 2	POST_URM	<ol style="list-style-type: none"> <li>1. Caller's parameter list</li> <li>2. Call type</li> <li>3. Caller's user name</li> <li>4. Parameters passed to DFHXCURM</li> <li>5. URMINV, reason for calling URM</li> <li>6. URMCIICS, target CICS applid</li> <li>7. URMANCH, URM anchor point address</li> </ol>
EX 2009	DFHXCPRH	EX 2	PRE-RACROUTE	<ol style="list-style-type: none"> <li>1. Caller's parameter list</li> <li>2. Call type</li> <li>3. Caller's user name</li> <li>4. Userid</li> <li>5. Surrogate resource name</li> <li>6. RACROUTE parameter list</li> </ol>
EX 200A	DFHXCPRH	EX 2	POST-RACROUTE	<ol style="list-style-type: none"> <li>1. Caller's parameter list</li> <li>2. Call type</li> <li>3. Caller's user name</li> <li>4. Userid</li> <li>5. Surrogate resource name</li> <li>6. RACROUTE parameter list</li> </ol>
EX 3000	DFHXCEIP	Exc	ESTAE_SETUP_ERROR	<ol style="list-style-type: none"> <li>1. Return area (20 bytes)</li> <li>2. MVS return code</li> </ol>
EX 3001	DFHXCEIP	Exc	ESTAE_INVOKED	<ol style="list-style-type: none"> <li>1. Return area (20 bytes)</li> </ol>
EX 3002	DFHXCEIP	Exc	INV_CTYPE_ON_INIT	<ol style="list-style-type: none"> <li>1. Return area (20 bytes)</li> <li>2. Call type</li> </ol>
EX 3003	DFHXCEIP	Exc	INV_VNUM_ON_INIT	<ol style="list-style-type: none"> <li>1. Return area (20 bytes)</li> <li>2. Version number</li> </ol>
EX 3004	DFHXCEIP	Exc	INV_APPL_NAME_ON_INIT	<ol style="list-style-type: none"> <li>1. Return area (20 bytes)</li> <li>2. User name</li> </ol>
EX 3005	DFHXCEIP	Exc	INV_CTYPE_ON_ALLOC	<ol style="list-style-type: none"> <li>1. Return area (20 bytes)</li> <li>2. Call type</li> </ol>
EX 3006	DFHXCEIP	Exc	INV_VNUM_ON_ALLOC	<ol style="list-style-type: none"> <li>1. Return area (20 bytes)</li> <li>2. Version number</li> </ol>
EX 3007	DFHXCEIP	Exc	INV_UTOKEN_ON_ALLOC	<ol style="list-style-type: none"> <li>1. Return area (20 bytes)</li> <li>2. User token</li> </ol>
EX 3008	DFHXCEIP	Exc	INV_CTYPE_ON_OPEN	<ol style="list-style-type: none"> <li>1. Return area (20 bytes)</li> <li>2. Call type</li> </ol>
EX 3009	DFHXCEIP	Exc	INV_VNUM_ON_OPEN	<ol style="list-style-type: none"> <li>1. Return area (20 bytes)</li> <li>2. Version number</li> </ol>
EX 3010	DFHXCEIP	Exc	INV_UTOKEN_ON_OPEN	<ol style="list-style-type: none"> <li>1. Return area (20 bytes)</li> <li>2. User token</li> </ol>

Table 7. External CICS interface trace entries (continued)

Point ID	Module	Lvl	Type	Data
EX 3011	DFHXCEIP	Exc	INV_PTOKEN_ON_OPEN	1. Return area (20 bytes) 2. Pipe token
EX 3012	DFHXCEIP	Exc	INV_CTYPE_ON_DPL	1. Return area (20 bytes) 2. Call type
EX 3013	DFHXCEIP	Exc	INV_VNUM_ON_DPL	1. Return area (20 bytes) 2. Version number
EX 3014	DFHXCEIP	Exc	INV_UTOKEN_ON_DPL	1. Return area (20 bytes) 2. User token
EX 3015	DFHXCEIP	Exc	INV_PTOKEN_ON_DPL	1. Return area (20 bytes) 2. Pipe token
EX 3017	DFHXCEIP	Exc	INV_USERID_ON_DPL	1. Return area (20 bytes)
EX 3018	DFHXCEIP	Exc	PIPE_NOT_OPEN_ON_DPL	1. Return area (20 bytes) 2. Pipe token
EX 3019	DFHXCEIP	Exc	PIPE_MUST_CLOSE_ON_DPL	1. Return area (20 bytes) 2. Pipe token
EX 3020	DFHXCEIP	Exc	INV_CTYPE_ON_CLOSE	1. Return area (20 bytes) 2. Call type
EX 3021	DFHXCEIP	Exc	INV_VNUM_ON_CLOSE	1. Return area (20 bytes) 2. Version number
EX 3022	DFHXCEIP	Exc	INV_UTOKEN_ON_CLOSE	1. Return area (20 bytes) 2. User token
EX 3023	DFHXCEIP	Exc	INV_PTOKEN_ON_CLOSE	1. Return area (20 bytes) 2. Pipe token
EX 3024	DFHXCEIP	Exc	INV_CTYPE_ON_DEALL	1. Return area (20 bytes) 2. Call type
EX 3025	DFHXCEIP	Exc	INV_VNUM_ON_DEALL	1. Return area (20 bytes) 2. Version number
EX 3026	DFHXCEIP	Exc	INV_UTOKEN_ON_DEALL	1. Return area (20 bytes) 2. User token
EX 3027	DFHXCEIP	Exc	INV_PTOKEN_ON_DEALL	1. Return area (20 bytes) 2. Pipe token
EX 3028	DFHXCEIP	Exc	PIPE_NOT_CLOSED_ON_DEALL	1. Return area (20 bytes) 2. Pipe token
EX 3029	DFHXCEIP	Exc	XCEIP_RETRYING	1. Return area (20 bytes)
EX 3030	DFHXCEIP	Exc	SURROGATE_CHECK_FAILED	1. Return area (20 bytes)
EX 4000	DFHXCGUR	EX 1	Entry	1. DFHXCGUR parameter list
EX 4001	DFHXCGUR	EX 2	Exit	1. DFHXCGUR parameter list
EX 4002	DFHXCGUR	EX 1	PRE_SVC1	1. SVC parameter list
EX 4003	DFHXCGUR	EX 1	POST_SVC	1. SVC parameter list
EX 4004	DFHXCGUR	Exc	RRMS_NOT_SUPPORTED	1. None
EX 4005	DFHXCGUR	Exc	RRMS_ERROR	1. None
EX 4006	DFHXCGUR	Exc	SVC_EXCEPTION	1. SVC return code

Table 7. External CICS interface trace entries (continued)

Point ID	Module	Lvl	Type	Data
EX 4007	DFHXCGUR	Exc	GETMAIN ERROR	1. None
EX 4201	DFHXCCR	Entry	S2GF GETMAIN	1. S2GF Plist
EX 4202	DFHXCCR	Exit	S2GF GETMAIN	1. S2GF Plist
EX 4203	DFHXCCR	Exc	GETMAIN failure	1. MVS IARCP64 build return code
EX 4204	DFHXCCR	Exc	GETMAIN failure	1. MVS IARCP64 get return code
EX 5000	DFHXCBA	Ex 1	Entry	1. Arg0 2. EIEI Plist
EX 5001	DFHXCBA	Ex 1	Exit	1. Arg0 2. EIEI Plist
EX 5002	DFHXCBA	Exc	Invalid function	1. EIEI Plist
EX 5003	DFHXCBA	Exc	Invalid format	1. EIEI Plist
EX 5004	DFHXCBA	Exc	Invalid API function	1. Arg0
EX 5005	DFHXCBA	Exc	ESTAE_INVOKED	1. EIEI Plist



---

## Chapter 6. Response and reason codes returned on EXCI calls

This section gives details of the reason codes for the responses returned on the EXCI call interface.

**Note:** All numeric response and reason code values shown are in decimal.

### Reason code for response: OK

---

#### **0: NORMAL**

Call completed normally.

#### **Explanation**

### Reason codes for response: WARNING

---

#### **1: PIPE\_ALREADY\_OPEN**

An Open\_Pipe request has been issued for a pipe that is already open.

#### **Explanation**

#### **System Action**

None. The pipe remains open.

#### **User Response**

If this response is unexpected, investigate whether an incorrect pipe token has been used on the Open\_Pipe call.

#### **2: PIPE\_ALREADY\_CLOSED**

A Close\_Pipe request has been issued for a pipe that is already closed.

#### **Explanation**

#### **System Action**

The external CICS interface ignores the request and the pipe remains closed.

#### **User Response**

If the response is unexpected, check that the Close\_Pipe call is specifying the correct pipe token.

### **3: VERIFY\_BLOCK\_FM\_ERROR**

Initialize\_User processing requires storage below 16MB to build the parameter list for the SSI Verify call, and an error has occurred during the FREEMAIN for this area.

#### **Explanation**

#### **System Action**

The return code from the FREEMAIN is returned in the EXCI subreason field-1. The Initialize\_User request continues unaffected.

#### **User Response**

If the problem persists, take a memory dump of the batch region and use the memory dump, together with the return code from the MVS FREEMAIN, to determine why the FREEMAIN is failing.

### **4: WS\_FREEMAIN\_ERROR**

An attempt to FREEMAIN working storage has resulted in an MVS FREEMAIN error.

#### **Explanation**

#### **System Action**

The return code from the FREEMAIN is returned in the EXCI subreason field-1. The Initialize\_User request continues unaffected.

#### **User Response**

If the problem persists, take a memory dump of the batch region and use the memory dump, together with the return code from the MVS FREEMAIN to determine why the FREEMAIN is failing.

### **5: XCPIPE\_FREEMAIN\_ERROR**

An attempt to FREEMAIN pipe storage has resulted in an MVS FREEMAIN error.

#### **Explanation**

#### **System Action**

The return code from the FREEMAIN is returned in the EXCI subreason field-1. However, the external CICS interface continues processing the Deallocate\_Pipe request. If the request fails with another error, this reason code is overwritten.

#### **User Response**

If the problem persists, take a memory dump of the client application program address space, and use the memory dump, with the return code from the MVS FREEMAIN to determine why the FREEMAIN is failing.

### **6: IRP\_IOAREA\_FM\_FAILURE**

An attempt to FREEMAIN an MRO I/O area has resulted in an MVS FREEMAIN error.

#### **Explanation**

## System Action

The return code from the FREEMAIN is returned in the EXCI subreason field-1, but the DPL request continued to completion. Reason IRP\_IOAREA\_FM\_FAILURE is returned to your application only if the DPL request completes, otherwise it is overwritten by subsequent response and reason codes.

## User Response

If the problem persists, take a memory dump of the batch region and use it with the return code from the MVS FREEMAIN to determine why the FREEMAIN is failing.

## 7: SERVER\_TERMINATED

The CICS session, on which the server program has been executing, has been freed by CICS.

## Explanation

### System Action

The CICS application server program has been detached at some point in its processing, and control is returned to the external CICS interface, which writes a trace entry for this error.

### User Response

The most likely reason for this error is that the server program has caused CICS to terminate, perhaps by an EXEC CICS PERFORM SHUTDOWN command. During shutdown, CICS frees EXCI sessions so that shutdown can complete.

## 8: XFRASTG1\_FM\_FAILURE

An attempt to FREEMAIN the transmission area has resulted in an MVS FREEMAIN error.

## Explanation

### System Action

The return code from the FREEMAIN is returned in the EXCI subreason field-1 but the DPL request continued to completion. Reason XFRASTG1\_FM\_FAILURE is returned to your application only if the DPL request completes, otherwise it is overwritten by subsequent response and reason codes.

### User Response

If the problem persists, take a memory dump of the batch region and use it with the return code from the MVS FREEMAIN to determine why the FREEMAIN is failing.

## Reason codes for response: RETRYABLE

---

### 201: NO\_CICS\_IRC\_STARTED

An Initialize\_User command has been issued on an MVS image that has had no IRC activity since the previous IPL, and the external CICS interface cannot determine the CICS SVC number.

## Explanation

## System Action

The Initialize\_User call fails, and the external CICS interface invokes the user-replaceable module, DFHXCURM.

## User Response

Ensure that a CICS region in the MVS image has logged on to IRC (that is, has started up with the system initialization parameter IRCSTRT=YES or has started IRC dynamically with an OPEN IRC command). Alternatively, if there is no local CICS region in the MVS image, you must specify the SVC parameter that the external CICS interface is to use, by coding a CICSSVC parameter in the DFHXCOPT table. This situation can occur if you are using XCF to communicate to a CICS region in another MVS image. Once the problem has been resolved, re-issue the Initialize\_User request.

## 202: NO\_PIPE

An attempt has been made to open a pipe, but the target CICS system associated with the pipe has no free receive sessions.

## Explanation

### System Action

The Open\_pipe call fails, and the external CICS interface invokes the user-replaceable module, DFHXCURM.

### User Response

This situation can occur even if the client application program has allocated (using Allocate\_Pipe calls) no more pipes than the number of receive sessions defined on the target connection. This is because CICS can be in the process of cleaning up a pipe from a Close\_Pipe request. For this reason, you are recommended to specify a larger RECEIVECOUNT value than is theoretically necessary when defining the SESSIONS resource definition to CICS. The application program can reissue the Open\_Pipe request.

## 203 (on Open\_Pipe call): NO\_CICS

An attempt has been made to open a pipe but the target CICS system is not available, or hasn't yet opened IRC, or the target connection is out of service, or the relevant EXCI connection definition is not installed in the target CICS.

### System Action

The open pipe request fails, and the external CICS interface invokes the user-replaceable module, DFHXCURM.

### User Response

If the subreason field-1 is non-zero (the IRP response code (R15)), the subreason field-2 contains the IRP reason code. For an explanation of the IRP return codes, see the interregion control blocks in the [Data areas](#). The IRP return codes are in the DFHIRSPS copybook, listed under the heading IRC.

The client program should deallocate the pipe. When you have corrected the problem, your client application program can reissue the allocate\_pipe and Open\_Pipe calls, or alternatively allocate and open a pipe to a different CICS region.



## 204: WRONG\_MVS\_FOR\_RRMS

A DPL request omitting the SYNCONRETURN option has been made specifying a CICS region that is on a different MVS system from the batch program. Because the Recoverable Resource Management Services (RRMS) context is not recognised in the target system, the request is rejected.

### Explanation

### System Action

The DPL request fails, and the external CICS interface invokes the user-replacable module, DFHXCURM.

### User Response

Ensure that the batch program that issued the DPL request and the CICS region it was sent to are on the same MVS system.

## 205: RRMS\_NOT\_AVAILABLE

A DPL request omitting the SYNCONRETURN option has been made when the Resource Recovery Services (RRS) is not available.

### Explanation

There are two cases:

- When Resource Recovery Services (RRS) is not available.
- When Resource Recovery Services has restarted since the last DPL request omitting the SYNCONRETURN option, and there has been no intervening syncpoint.

--

**Note:** RRS is a part of Recoverable Resource Management Services (RRMS).

### System Action

The DPL request fails, and the external CICS interface invokes the user-replacable module, DFHXCURM.

### User Response

Retry the DPL request when Resource Recovery Services has restarted since the last DPL request omitting the SYNCONRETURN option, and there has been no intervening syncpoint.

## Reason codes for response: USER\_ERROR

---

## 401: INVALID\_CALL\_TYPE

### Explanation

An invalid *call-type* parameter value is specified on this EXCI request.

### System Action

The request is rejected.

## User Response

Check your EXCI client program and ensure the *call\_type* parameter specifies the appropriate value for the EXCI call, as follows.

- 1 Initialize\_User
- 2 Allocate\_Pipe
- 3 Open\_Pipe
- 4 Close\_Pipe
- 5 Deallocate\_Pipe
- 6 DPL

## 402: INVALID\_VERSION\_NUMBER

### Explanation

The *version\_number* parameter does not specify a value of 1, 2, or 3.

### System Action

The request is rejected.

### User Response

Check the client application program and ensure that all EXCI calls specify the value of 1, 2, or 3 for the version number.

## 403: INVALID\_APPL\_NAME

### Explanation

The *user\_name* parameter consists of all blank characters (X'40').

### System Action

The call is rejected.

### User Response

Change the application program to specify a valid, non-blank user name.

## 404: INVALID\_USER\_TOKEN

### Explanation

The client application program has issued an EXCI request using a user token that is unknown to the external CICS interface.

### **System Action**

The request is rejected.

### **User Response**

The Initialize\_User call returns a 4-byte token that must be used on *all* further requests for the that user. Check the client application program and correct the error to ensure that the correct token is passed.

## **405: PIPE\_NOT\_CLOSED**

### **Explanation**

A Deallocate\_Pipe request has been issued against a pipe that has not yet been closed.

### **System Action**

The external CICS interface ignores the request and the pipe remains open.

### **User Response**

Check the client application program, and ensure that the Deallocate\_Pipe request is intended. If so, issue a Close\_Pipe request for the pipe before issuing the Deallocate\_Pipe request.

## **406: PIPE\_NOT\_OPEN**

### **Explanation**

A DPL call has been issued on a pipe that is not open.

### **System Action**

The external CICS interface rejects the DPL request.

### **User Response**

Check the client application program, and ensure that an Open\_Pipe request is issued before using the pipe on a DPL request. If an Open\_Pipe has been issued by the application program, check that it has not been closed inadvertently before all the DPL requests have been made.

## **407: INVALID\_USERID**

A DPL request has been issued with a USERID parameter that consists of all blanks.

### **Explanation**

### **System Action**

The DPL request is rejected.

### **User Response**

Check the EXCI client program and ensure that the DPL request passes a valid USERID parameter. If you don't want to specify a userid, code the call parameter list with a null address for *userid*. If you pass a null address, the external CICS interface passes the userid under which the client application program is running (the batch region's userid).

## 408: INVALID\_UOWID

A DPL request has been issued with a *uowid* parameter that has invalid length fields.

### Explanation

### System Action

The DPL request is rejected.

### User Response

Check the client application program and ensure that the DPL request passes a valid *uowid* parameter. If you don't want to specify a unit of work id, code the call parameter list with a null address for *uowid*, in which case the external CICS interface generates a unit of work id for you.

## 409: INVALID\_TRANSID

A DPL request has been issued with a *transid* parameter that consists of all blanks.

### Explanation

### System Action

The DPL request is rejected.

### User Response

Check the client application program and ensure that the *transid* parameter is specified correctly or has not been overwritten in some way. If you don't want to specify your own *transid*, code the call parameter list with a null address for *transid*, in which case the external CICS interface uses the default CICS mirror transaction, CSMI.

## 410: DFHMEBM\_LOAD\_FAILED

During Initialize\_User processing, the external CICS interface attempted to load the main message module in preparation for issuing external CICS interface messages, and the load of this module failed.

### Explanation

### System Action

The Initialize\_User call is rejected. The return code from the MVS load macro (R15) is returned in the subreason field-1. The external CICS interface handles the error, and returns the abend (R0) that would have occurred in the subreason field-2.

### User Response

Using the MVS return code, determine why the load failed. The most likely reason is that the message module, DFHMEBMX, is not in any library included in the STEPLIB of the batch job. Ensure the CICSTS55.CICS.SDFHEXCI library is included in the STEPLIB concatenation, and restart the client application program.

## 411: DFHMET4E\_LOAD\_FAILED

The load of message module, DFHMET4E, has failed. During Initialize\_User processing, the external CICS interface attempted to load its message table in preparation for issuing messages. The load of this module failed.

### Explanation

### System Action

The Initialize\_User call is rejected. The return code from the MVS load macro (R15) is returned in the subreason field-1. The external CICS interface handles the error, and returns the abend (R0) that would have occurred in the subreason field-2.

### User Response

Using the MVS reason code, determine why the load failed. The most likely reason is that the message table, DFHMET4E, is not in any library included in the STEPLIB of the batch job. Ensure the CICS55.CICS.SDFHEXCI library is included in the STEPLIB concatenation, and restart the client application program.

## 412: DFHXCURM\_LOAD\_FAILED

During Initialize\_User processing, the external CICS interface attempted to load the user-replaceable module, DFHXCURM. The load of this module failed.

### Explanation

### System Action

The Initialize\_User call is rejected. The return code from the MVS load macro (R15) is returned in the subreason field-1. The external CICS interface handles the error, and returns the abend (R0) that would have occurred in the subreason field-2.

### User Response

Using the MVS reason code, determine why the load failed. The most likely reason is that module DFHXCURM is not in any library included in the STEPLIB of the batch job. Ensure the library containing the module is included in the STEPLIB concatenation, and restart the client application program.

## 413: DFHXCTRA\_LOAD\_FAILED

During Initialize\_User processing, the external CICS interface attempted to load the trap module (DFHXCTRA). The load of this module has failed.

### Explanation

### System Action

The Initialize\_User call is rejected. The return code from the MVS load macro (R15) is returned in the subreason field-1. The external CICS interface handles the error, and returns the abend (R0) that would have occurred in the subreason field-2.

## **User Response**

Using the MVS reason code, determine why the load failed. The most likely reason is that DFHXCTRA is not in any library included in the STEPLIB of the batch job. Ensure the library containing the module is included in the STEPLIB concatenation, and restart the client application program.

## **414: IRP\_ABORT\_RECEIVED**

While processing a DPL request, an error occurred in the CICS server region, resulting in an abort FMH7 flow being returned to the external CICS interface.

### **Explanation**

### **System Action**

A message is returned to the client application program. This is the message that would have been issued to the terminal if the server program had been initiated from a terminal. A pointer to the message is returned to the client application program in the message pointer field of the EXCI return area. See the description of the EXCI return areas for the exact definition of the message format. The pipe is put into a "must close" state.

### **User Response**

Use the message to determine the cause of the error. A typical example is where the server transaction cannot be attached, either because it is disabled, or it has not been defined, or because of a security failure. Correct the problem, close and reopen the pipe, and reissue the DPL request.

## **415: INVALID\_CONNECTION\_DEFN**

A DPL request has been rejected by CICS because the target connection is not defined for use by an external CICS client application program.

### **Explanation**

### **System Action**

The DPL request is rejected and the pipe is put into a "must close" state.

### **User Response**

The most likely reason for this is that the connection definition in the CICS server region has been defined incorrectly as a CICS-to-CICS MRO connection, instead of an EXCI connection. Ensure that PROTOCOL(EXCI) is specified on the appropriate CONNECTION and SESSIONS resource definitions. You must close and reopen the pipe before reissuing the DPL request.

## **416: INVALID\_CICS\_RELEASE**

A DPL request has been rejected by the target CICS server region because it doesn't recognize the request.

### **Explanation**

### **System Action**

The DPL call is rejected and the pipe is put into a "must close" state.

## **User Response**

The most likely reason for this is that the client application program has specified a target CICS server region that does not support the external CICS interface. CICS regions earlier than CICS for MVS/ESA 4.1 do not recognize EXCI call requests. Correct the problem, close and reopen the pipe and then reissue the DPL request.

## **417: PIPE\_MUST\_CLOSE**

A DPL request has been issued on a pipe that is in a "must close" state.

### **Explanation**

### **System Action**

The DPL request is rejected.

### **User Response**

Some EXCI errors are serious enough to require that the pipe be closed and reopened in order to restore the pipe to a point where it can be used for further DPL requests. Others, more minor errors, allow further calls without closing and reopening the pipe. A previous error on this pipe has been of the more serious variety and the pipe is now in a "must close" state. Close and reopen the pipe and reissue the DPL request.

## **418: INVALID\_PIPE\_TOKEN**

An Open\_Pipe, Close\_Pipe, Deallocate\_Pipe, or DPL request has been issued, but the pipe token passed on the call is either not a valid pipe, or is not a valid pipe allocated for this user (that is, there is mismatch between the user token and the pipe token).

### **Explanation**

### **System Action**

The call is rejected.

### **User Response**

Ensure that the pipe token has not been overwritten and is being passed correctly on the call. Also ensure there is no mismatch between the user token and the pipe token.

## **419: CICS\_AFCB\_PRESENT**

An Initialize\_User request has been issued on a TCB that has already been used by CICS or by CICS batch shared database. The external CICS interface cannot share a TCB with CICS, ensuring that a CICS application program cannot issue EXCI requests.

### **Explanation**

### **System Action**

The Initialize\_User request is rejected.

## **User Response**

To use the external CICS interface, you must create a new TCB (or daughter TCB), and issue the EXCI calls under that unique TCB.

### **420: DFHXCOPT\_LOAD\_FAILED**

During Initialize\_User processing, the external CICS interface attempted to load its options module, DFHXCOPT. The load of this module failed.

#### **Explanation**

#### **System Action**

The Initialize\_User call is rejected. The return code from the MVS load macro (R15) is returned in the subreason field-1. The external CICS interface handles the error, and returns the abend (R0) that would have occurred in the subreason field-2.

#### **User Response**

Using the MVS reason code, determine why the load failed. The most likely reason is that DFHXCOPT is not in any library included in the STEPLIB of the batch job. Correct the problem and restart the client application program.

### **421: RUNNING\_UNDER\_AN\_IRB**

The EXCI call is issued under an MVS IRB, which is not permitted.

#### **Explanation**

#### **System Action**

The call is rejected.

#### **User Response**

Determine why the call was issued under an IRB and change the client application program.

### **422: SERVER\_ABENDED**

While processing a DPL request, the CICS server application program abended without handling the error.

#### **Explanation**

#### **System Action**

The server application program is abended and backout out. The abend code is returned in the abend code field of the EXCI return area.

#### **User Response**

Determine why the server program abended and fix the problem.



## 423: SURROGATE\_CHECK\_FAILED

### Explanation

A DPL request has been issued specifying a USERID parameter. The userid specified was subject to a surrogate user check. The surrogate user check failed. The surrogate security check verifies whether the EXCI batch region's userid is authorized as a surrogate of the userid specified on the DPL call.

### System Action

The DPL call is rejected. The MVS external security manager's return code and reason code are returned in subreason field-1 and field-2. For RACF, these are documented in the [z/OS Security Server RACROUTE Macro Reference](#).

### User Response

Ensure that the EXCI batch region's userid has READ access to the profile *userid.DFHEXCI* in the SURROGAT general resource class, where *userid* is the userid specified on the DPL call.

See [Surrogate user checking](#) for more information.

## 424: RRMS\_NOT\_SUPPORTED

A DPL request omitting the SYNCONRETURN option has been made on a system that is not running z/OS Release 5 (or a later, upward-compatible, release).

### Explanation

### System Action

The call is rejected.

### User Response

Ensure that the batch program is run on a system that is running the correct level of z/OS.

## 425: UOWID\_NOT\_ALLOWED

A DPL request omitted the SYNCONRETURN option, but specified a value of UOWID. This combination of parameters is not permitted on a DPL request.

### Explanation

### System Action

The DPL\_Request is rejected.

### User Response

Check the client application program and ensure that the correct combination of parameters is used on the DPL call.

## 426: INVALID\_TRANSID2

A DPL request has been issued with a *transid2* parameter that consists of all blanks.

### Explanation

### **System Action**

The DPL request is rejected.

### **User Response**

Check the client application program and ensure that the *transid2* parameter is specified correctly or has not been overwritten in some way.

## **427: INVALID\_CCSID**

### **Explanation**

A DPL request has been issued with a *ccsid* parameter that specifies an invalid value.

### **System Action**

The DPL request is rejected.

### **User Response**

Check the client application program and ensure that the *ccsid* parameter is specified correctly or has not been overwritten in some way.

## **428: INVALID\_ENDIAN**

### **Explanation**

A DPL request has been issued with a *endian* parameter that specifies an invalid value.

### **System Action**

The DPL request is rejected.

### **User Response**

Check the client application program and ensure that the *endian* parameter is specified correctly or has not been overwritten in some way.

## **429: DFHXCEIX\_LOAD\_FAILED**

### **Explanation**

During processing of an **EXEC CICS LINK** call, the external CICS interface attempted to load the module (DFHXCEIX). The load of this module has failed.

### **System Action**

The **EXEC CICS LINK** call is rejected.

### **User Response**

The most likely reason is that DFHXCEIX is not in any library included in the STEPLIB of the batch job. Ensure the library containing the module is included in the STEPLIB concatenation, and restart the client application program.

## 430: DFHXCPRX\_LOAD\_FAILED

### Explanation

During Initialize\_User processing, the external CICS interface attempted to load the module (DFHXCPRX). The load of this module has failed.

### System Action

The Initialize\_User call is rejected. The return code from the MVS load macro (R15) is returned in the subreason field-1. The external CICS interface handles the error, and returns the abend (R1) that would have occurred in the subreason field-2.

### User Response

Using the MVS reason code, determine why the load failed. The most likely reason is that DFHXCPRX is not in any library included in the STEPLIB of the batch job. Ensure the library containing the module is included in the STEPLIB concatenation, and restart the client application program.

## 431: COMMAREA\_LEN\_NOT\_ALLOWED

### Explanation

A DPL request that specifies a **CHANNEL** parameter and a **COMMAREA\_LEN** parameter has been issued. When a channel is used to transfer data between programs, the **COMMAREA\_LEN** parameter must be null.

### System Action

The request is rejected.

### User Response

Check your EXCI program. If it contains a DPL request that specifies a channel, ensure that the **COMMAREA\_LEN** parameter is null.

## 432: DATA\_LEN\_NOT\_ALLOWED

### Explanation

A DPL request that specifies a **CHANNEL** parameter and a **DATA\_LEN** parameter has been issued. When a channel is used to transfer data between programs, the **DATA\_LEN** parameter must be null.

### System Action

The request is rejected.

### User Response

Check your EXCI program. If it contains a DPL request that specifies a channel, ensure that the **DATA\_LEN** parameter is null.

## 433: CCSID\_NOT\_ALLOWED

### Explanation

A DPL request that specifies a **CHANNEL** parameter and a **CCSID** parameter has been issued. When a channel is used to transfer data between programs, the **CCSID** parameter must be null.

### System Action

The request is rejected.

### User Response

Check your EXCI program. If it contains a DPL request that specifies a channel, ensure that the **CCSID** parameter is null.

## 434: ENDIAN\_NOT\_ALLOWED

### Explanation

A DPL request that specifies a **CHANNEL** parameter and a **ENDIAN** parameter has been issued. When a channel is used to transfer data between programs, the **ENDIAN** parameter must be null.

### System Action

The request is rejected.

### User Response

Check your EXCI program. If it contains a DPL request that specifies a channel, ensure that the **ENDIAN** parameter is null.

## Reason codes for response: SYSTEM\_ERROR

---

## 601: WS\_GETMAIN\_ERROR

During Initialize\_User processing, a GETMAIN for working storage failed.

### System Action

Processing cannot continue without working storage, so the request is terminated. At this point the external CICS interface trace and dump services are not available to provide diagnostic information, therefore EXCI issues an MVS abend (U0408) to force a SYSMDUMP. The return code from the MVS GETMAIN request is returned in the return area.

### User Response

Locate the GETMAIN return code in the dump, and use this and the rest of the dump to determine why the GETMAIN failed. A possible reason for this is that the region size specified for the job is too small. If this is the case, increase the region size and restart the client application program.

## 602: XCGLOBAL\_GETMAIN\_ERROR

During Initialize\_User processing, a GETMAIN failed for a critical control block (XCGLOBAL).

### System Action

Processing cannot continue without this control block, and the request is terminated. At this point the external CICS interface trace and dump services are not available to provide diagnostic information, therefore EXCI issues an MVS abend (U0403) to force a SYSMDUMP. The return code from the MVS GETMAIN request is returned in the return area.

### User Response

Locate the GETMAIN return code in the dump, and use this and the rest of the dump to determine why the GETMAIN failed. A possible reason for this is that the region size specified for the job is too small. If this is the case, increase the region size and restart the client application program.

## 603: XCUSER\_GETMAIN\_ERROR

During Initialize\_User processing, a GETMAIN request failed for the user control block (XCUSER).

### System Action

Initialize\_User processing is terminated. The return code from the GETMAIN is returned in subreason field-1 of the return area. The external CICS interface issues message DFHEX0003 and issues an MVS user abend (0410) to force a SYSMDUMP.

### User Response

Use the return code from the GETMAIN, with the dump, to determine why the GETMAIN failed. A possible reason for this is that the region size of the job is too small. If this is the case, increase the region size and restart the client application program.

## 604: XCPIPE\_GETMAIN\_ERROR

During Allocate\_Pipe processing, a GETMAIN request for the pipe control block (XCPIPE) failed.

### System Action

Allocate\_Pipe processing is terminated. The return code from the GETMAIN is returned in subreason field-1 of the EXCI return area. The external CICS interface issues message DFHEX0003, and takes a system dump.

### User Response

Use the return code from the GETMAIN, and the dump, to determine why the GETMAIN failed. A possible reason for this is that the region size for the job is too small. If this is the case, increase the region size and restart the client application program.

## 605: VERIFY\_BLOCK\_GM\_ERROR

During Initialize\_User processing, a GETMAIN failed for an EXCI internal control block.

### System Action

Initialize\_User processing is terminated. The return code from the GETMAIN is returned in the subreason field-1 of the EXCI return area. This error occurs before EXCI dumping services are initialized, Therefore EXCI issues an MVS abend (U0409) to force a SYSMDUMP The return code from the MVS GETMAIN request is returned in the return area.

## User Response

Locate the GETMAIN return code in the dump, and use this and the rest of the dump to determine why the GETMAIN failed. A possible reason for this is that the region size specified for the job is too small. If this is the case, increase the region size and restart the client application program.

## 606: SSI\_VERIFY\_FAILED

A VERIFY call to the MVS subsystem interface (SSI) to obtain the current CICS SVC number failed.

### System Action

The Initialize\_User request is terminated. The return code from the SSI call is returned in subreason field-1 of the return area. This error occurs before the external CICS interface dump services are initialized, therefore EXCI issues an MVS user abend (0405) to force a SYSMDUMP.

### User Response

Locate the return code in the dump, and use this with the rest of the dump and SSI documentation to determine why the VERIFY request failed. When the problem is resolved, restart the client application program.

## 607: CICS\_SVC\_CALL\_FAILURE

During Initialize\_User processing, a call to the currently installed CICS SVC failed.

### System Action

The return code from the CICS SVC is returned in the subreason field-1 of the EXCI return area. This error occurs before the external CICS interface dump services are initialized, therefore EXCI issues an MVS user abend (0406) to force a SYSMDUMP.

### User Response

Contact your IBM support center for assistance, with the return code and the dump available.

## 608: IRC\_LOGON\_FAILURE

During Allocate\_Pipe processing, an attempt by the external CICS interface to LOGON to DFHIRP failed.

### System Action

The Allocate\_Pipe request fails. DFHIRP returns a R15 value to subreason field-1 and a R0 value (the reason code) to subreason field-2. The first two bytes of subreason field-1 are the return code qualifier and the last two bytes are the return code itself.

### User Response

For an explanation of the IRP return codes, see the interregion control blocks in the [Data areas](#). The IRP return codes are in the DFHIRSPS copybook, listed under the heading IRC. Use the return codes to determine why the logon failed, or contact your IBM support personal with details of the failure.

## 609: IRC\_CONNECT\_FAILURE

During Open\_Pipe processing, an attempt to connect to the target CICS system failed.

### System Action

The Open\_Pipe request fails. DFHIRP returns a R15 value to subreason field-1 and a R0 value (the reason code) to subreason field-2. The first two bytes of subreason field-1 are the return code qualifier and the last two bytes are the return code itself.

### User Response

For an explanation of the IRP return codes, see the interregion control blocks in the [Data areas](#). The IRP return codes are in the DFHIRSPS copybook, listed under the heading IRC.

Use the return code to determine why the logon failed, and reissue the open pipe request.

**Note:** This error is not caused by the target CICS being unavailable, which is returned as a RETRYABLE condition (NO\_CICS).

## 610: IRC\_DISCONNECT\_FAILURE

During Close\_Pipe processing, CICS issued a DFHIRP disconnect call to terminate the connection to CICS. This request has failed.

### System Action

The call fails and the pipe remains open. DFHIRP returns a R15 value to subreason field-1 and a R0 value (the reason code) to subreason field-2. The first two bytes of subreason field-1 are the return code qualifier and the last two bytes are the return code itself.. The external CICS interface takes a system dump.

Although the disconnect failed, it is possible that the pipe is still connected to CICS. However, all connections are automatically disconnected at the end of the batch program.

### User Response

For an explanation of the IRP return codes, see the interregion control blocks in the [Data areas](#). The IRP return codes are in the DFHIRSPS copybook, listed under the heading IRC. Use the return code and the dump to determine the cause of the error.

## 611: IRC\_LOGOFF\_FAILURE

During Deallocate\_Pipe processing, CICS issued a DFHIRP logoff call. This request failed.

### System Action

The Deallocate\_Pipe call fails and the pipe remains allocated. DFHIRP returns a R15 value to subreason field-1 and a R0 value (the reason code) to subreason field-2. The first two bytes of subreason field-1 are the return code qualifier and the last two bytes are the return code itself. The external CICS interface takes a system dump.

**Note:** Because it remains allocated, the pipe is available for further calls. Any storage associated with the pipe is not freed. However, this storage is freed at the end of the client application program.

### User Response

For an explanation of the IRP return codes, see the interregion control blocks in [Data areas](#). The IRP return codes are in the DFHIRSPS copybook, listed under the heading IRC. Use the return code and the dump to determine the cause of the error.

## **612: TRANSFORM\_1\_ERROR**

During DPL processing, while processing the data in preparation for sending to CICS, an internal call to program DFHXFQ resulted in an error.

### **System Action**

The DPL request is terminated.

### **User Response**

The return code from the call is returned in the EXCI subreason field-1, and the external CICS interface takes a system dump.

This is an external CICS interface error. Contact your IBM support center with details of the return code and the dump.

## **613: TRANSFORM\_4\_ERROR**

During DPL processing, while processing the data returned by the CICS server region, an internal call to module DFHXFQ resulted in an error.

### **System Action**

The DPL request is terminated. Note that the server application program has executed. The return code from the call to DFHXFQ is returned in the EXCI subreason field-1. This return code corresponds to any EIBRCODE information that was available. The external CICS interface takes a system dump.

### **User Response**

This is an external CICS interface error. Contact your IBM support center with details of the return code and the dump.

## **614: IRP\_NULL\_DATA\_RECEIVED**

During DPL processing, a request has been sent to the target CICS and this target CICS has replied without returning any data.

### **System Action**

The DPL processing is terminated and the external CICS interface takes a system dump.

### **User Response**

This is an internal protocol error. Contact your IBM support center with details of the dump.

## **615: IRP\_NEGATIVE\_RESPONSE**

An internal protocol error has occurred while trying to communicate with the target CICS region.

### **System Action**

The DPL request fails, the pipe is put into a "must close" state, and the external CICS interface takes a system dump.

### **User Response**

This is an external CICS interface error. Keep the dump and contact your IBM support center.



**Note:** The pipe is in a "must close" state. Before attempting further calls, the pipe must first be closed and reopened.

## 616: IRP\_SWITCH\_PULL\_FAILURE

An internal protocol error has occurred while trying to communicate with the target CICS region.

### System Action

The DPL request fails, the pipe is put into a "must close" state, and the external CICS interface takes a system dump. The IRP return code (R15) and reason code if any (R0) are returned in the EXCI subreason field-1 and subreason field-2.

### User Response

This is an external CICS interface error. Keep the dump and contact your IBM support center.

**Note:** The pipe is in a "must close" state, and before attempting further DPL calls, the pipe must first be closed and reopened.

## 617: IRP\_IOAREA\_GM\_FAILURE

During DPL processing, an MVS GETMAIN request for an internal control block failed.

### System Action

The DPL request is terminated. The return code from the GETMAIN is returned in the EXCI subreason field-1.

**Note:** This error occurs while processing the data returned by CICS, after the server application program has completed execution. This error results in the pipe being put into a "must close" state.

### User Response

Use the return code to determine why the GETMAIN failed. A possible reason for this is that the region size of the job is too small. If this is the case, increase the region size and restart the batch job.

## 619: IRP\_BAD\_IOAREA

During a DPL request, an I/O area has been supplied to DFHIRP that could not be used.

### System Action

The DPL request is terminated, the pipe is forced into a "must close" state, and the external CICS interface takes a system dump.

### User Response

This is an external CICS interface error. Contact the IBM support center with details of the return code and the dump.

**Note:** The pipe is in a "must close" state after this error, and before attempting further calls must first be closed and reopened.

## 620: IRP\_PROTOCOL\_ERROR

An internal protocol error has occurred while trying to communicate with the target CICS system.

### System Action

The DPL request is terminated, the pipe is forced into a "must close" state, and the external CICS interface takes a system dump.

### User Response

This is an external CICS interface error. Keep the dump and contact your IBM support center.

**Note:** The pipe is in a "must close" state after this error, and before attempting further calls must first be closed and reopened.

## 621: PIPE\_RECOVERY\_FAILURE

An error has occurred during an open pipe request. The external CICS interface attempts to recover by disconnecting the pipe again. During this disconnection, further errors have occurred.

### System Action

The Open\_Pipe call is terminated and the pipe is placed in a "must close" state. The return code from DFHIRP is returned in the EXCI subreason field-1, and a system dump is taken.

### User Response

For an explanation of the IRP return codes, see the interregion control blocks in [Data areas](#). The IRP return codes are in the DFHIRSPS copybook, listed under the heading IRC. Use the dump and IRP return codes to determine why the disconnect failed. You may also want to use the EXCI trace to determine the earlier error that caused the open pipe recovery routine to be invoked.

**Note:** The pipe is now in a "must close" state and if further calls are to be issued, the pipe must be closed and reopened again first.

## 622: ESTAE\_SETUP\_FAILURE

In order to protect itself from possible program checks the external CICS interface establishes an MVS ESTAE. In this case, the MVS ESTAE macro has failed.

### System Action

The call terminated, and the return code from the MVS ESTAE command is returned in the EXCI subreason field-1. This error may occur before EXCI dump services are initialized, therefore an EXCI issues an MVS abend (U0402) to force a SYSMDUMP.

### User Response

Use the return code and the dump to determine why the ESTAE command failed. This may be an internal EXCI error and if the problem persists, contact your IBM support center.

## 623: ESTAE\_INVOKED

A program check is encountered during call processing, and the ESTAE is invoked.

### System Action

The program check is handled by the EXCI ESTAE and an attempt is made to recover to a state that can support further EXCI calls. The MVS abend code is returned in the EXCI subreason field-1 of the return area. To aid further diagnosis, a SYSMDUMP is taken.

### User Response

Use the return code and the dump to determine why a program check occurred in the external CICS interface. The most likely reason for this is that the EXCI code abended while trying to access the client program's parameters. Use the EXCI trace to determine if any of the parameters might have caused this error. If this is not the case, this may be an error in the external CICS interface. Keep the dump and contact your IBM support center.

## 624: SERVER\_TIMEDOUT

A DPL request has been issued and the target server program has executed in the CICS server region. However, the server program has been executing for longer than the timeout value specified in the DFHXCOPT table.

### System Action

The external CICS interface stops waiting for the server program to complete. Because the server program might complete some time after the timeout, and try to respond to the DPL call, the pipe is forced into a "must close" state.

### User Response

Determine why the server application program timed out. Either there is a problem with the server program itself (for example, it might be in a loop), or the timeout value is too low.

## 625: STIMER\_SETUP\_FAILURE

In order to provide a TIMEOUT mechanism, the external CICS interface issues an MVS STIMER macro call. This call has failed.

### System Action

The return code from the call is returned in the subreason field-1 of the EXCI return area. The DPL request is terminated and the external CICS interface takes a system dump. The pipe is placed in a "must close" state.

### User Response

Use the MVS return code and the dump to determine why the call failed. This could be an external CICS interface error. Contact your IBM support center with details of the dump.

**Note:** The pipe is in a "must close" state after this error, and before attempting further calls must first be closed and reopened.

## 626: STIMER\_CANCEL\_FAILURE

On successful completion of a DPL request, the cancel of an STIMERM request issued to check the TIMEOUT value has failed with an error.

### System Action

The return code from the STIMERM CANCEL is returned in the subreason field-1 of the EXCI return area. The pipe is placed in a "must close" state, and the external CICS interface takes a system dump.

### User Response

Use the return code and the dump to determine why the MVS STIMERM CANCEL command failed. This could be an external CICS interface error. Contact your IBM support center with details of the dump.

**Note:** The pipe is in a "must close" state after this error, and before attempting further calls must first be closed and reopened.

## 627: INCORRECT\_SVC\_LEVEL

The release level of the CICS SVC (DFHCSVC) is not the same (or higher) than the release level of the external CICS interface.

### System Action

The Initialize\_User request is terminated. This error occurs before the external CICS interface SDUMP facilities are initialized, therefore EXCI issues an MVS abend (U0407) to force a SYSMDUMP.

### User Response

Determine the level of the CICS SVC being used and ensure it is the same release level as the external CICS interface, or higher. If the SVC number is allowed to default (CICSSVC=0 in DFHXCOPT), the SVC number being used is the SVC first used by a CICS region on the MVS image. That is, the SVC used by the first CICS region to open the CICS interregion communications (IRC). If the SVC number is specified on CICSSVC in DFHXCOPT, the SVC number specified is at an incorrect level. For more information, see the description of the CICSSVC parameter in [Using the EXCI options table, DFHXCOPT](#).

## 628: IRP\_LEVEL\_CHECK\_FAILURE

The release level of the module DFHIRP is not at the same, or higher, level than the release level of the external CICS interface.

### System Action

The Allocate\_pipe request is terminated. The IRP return code (R15) is returned in the EXCI subreason field-1, and the function level of DFHIRP being used is returned in the EXCI subreason field-2. Subreason field-2 is only meaningful if subreason field-1 is zero. The external CICS interface takes a system dump.

### User Response

Check the level of the DFHIRP module installed in the LPA. Ensure that it is at least the same as the external CICS interface. The installed level of DFHIRP must be the highest level of CICS or external CICS interface in use in the MVS image. For more details about installing DFHIRP, see [Installing the modules DFHIRP and DFHCSVC in the LPA in Installing](#).

## 629: SERVER\_PROTOCOL\_ERROR

A response to a DPL request has been returned by CICS but the external CICS interface does not understand the response.

### System Action

The DPL request is terminated and the external CICS interface takes a system dump.

### User Response

Use the dump to determine why the response was in error. The most likely reason for this is that the CICS application server program was not running under the control of a CICS mirror task. This can happen if the transaction definition named by the transid parameter on the DPL call does not specify DFHMIRS as the program name. This would cause unidentified responses being sent from the CICS server region.

## 630: RRMS\_ERROR

An unexpected return code was received from Recoverable Resource Management Services (RRMS) while processing a DPL\_Request.

### System Action

DPL\_Request processing is terminated.

The value in subreason field-1 of the return area indicates which RRMS interface returned the unexpected return code:

- 1  
CTXRCC
- 2  
ATTRURD
- 3  
CTXSDTA

The return code from the RRMS request is returned in subreason field-2.

The external CICS interface issues message DFHEX0002, and takes a system dump.

### User Response

Use the return code from the RRMS request and the dump, to determine why the request failed. This may be an internal EXCI error or a problem with RRMS and you may need the assistance of your IBM support center.

## 631: RRMS\_SEVERE\_ERROR

During the processing of a DPL\_Request, the EXCI code encountered an unexpected error while using its interface with Recoverable Resource Management Services (RRMS).

### System Action

DPL\_Request processing is terminated.

The external CICS interface issues message DFHEX0002, and takes a system dump.

### User Response

Use the dump, to determine why the request failed. This may be an internal EXCI error and you may need the assistance of your IBM support center.

## **632: XCGUR\_GETMAIN\_ERROR**

During DPL\_Request processing, a GETMAIN request for working storage for module DFHXCGUR failed.

### **System Action**

DPL\_Request processing is terminated.

The return code from the GETMAIN is returned in subreason field-1 of the return area. The external CICS interface issues message DFHEX0003, and takes a system dump.

### **User Response**

Use the return code from the GETMAIN, and the dump, to determine why the GETMAIN failed. A possible reason is that the region size of the job is too small. If this is the case, increase the region size and restart the client application program.

## **633: INQUIRE\_CHANNEL\_FAILED**

During DPL\_Request processing, an INQUIRE\_CHANNEL request to obtain the channel token failed.

### **System Action**

DPL\_Request processing is terminated.

The external CICS interface issues message DFHEX0002, and takes a system dump.

### **User Response**

This is an external CICS interface error. Contact your IBM support center with details of the return code and the dump.

# Chapter 7. EXCI samples: channel and containers sample applications

To show you how to code client applications that use both the **EXCI CALL** interface and **EXEC CICS LINK** command, CICS provides sample MVS client programs and a sample CICS server program. A set of EXCI channel and containers sample applications shows using channels and containers to pass data to and receive data from CICS.

## About the EXCI channel and containers sample applications

The external CICS interface sample programs include two sample MVS client programs and a sample CICS server program. Data is passed between the clients and the server program using channels and containers.

Language	Name	Type of program
Assembler <sup>1</sup>	DFH\$AXNC	Client program
COBOL <sup>2</sup>	DFH0CXNC	Client program

### Notes:

1. Assembler language programs are in source and executable form.
2. COBOL programs are provided in source form only.

### The sample CICS server program

The sample CICS server program, DFH\$AXNS, is provided in assembler only and is in source and executable form.

### The sample MVS client program

The sample client program shows you how to code a simple MVS client application using the EXCI CALL interface and the **EXEC CICS LINK** command. The internal design of both client assembler and COBOL sample programs is the same.

**Note:** The assembler version of the client program uses BSAM, which requires the programs to be link-edited in RMODE(24), as a switch to AMODE(24) is made around the BSAM call. The assembler source code includes the required RMODE(24) statement. Normally, EXCI client programs run AMODE(31),RMODE(ANY). Therefore, the assembler version of the client program is unsuitable for use as Language Environment MAIN programs.

Each version of the client is divided into three separate sections as follows:

#### Section 1

Section 1 uses the EXEC interface to send containers to the server (CICS). The request is in a container called REQUEST\_TYPE and will contain either "LINK1" or "LINK2". The server program (DFH\$AXNS), described below, uses this container. For the first LINK request, a container called EBCDIC\_DATA is set up on channel FIRST\_CHANNEL with a simple text string. This is then sent by an **EXEC CICS LINK** request.

If the request succeeds an **EXEC CICS QUERY CHANNEL** request is issued to check how many containers are on the channel. There should be three because the server program will have added an EXCI\_RESPONSE container to the channel. A browse using **EXEC CICS STARTBROWSE CONTAINER**, **EXEC CICS GETNEXT CONTAINER** and **EXEC CICS ENDBROWSE CONTAINER** requests is then

performed to browse the names of the containers on the channel. This query and browse is not necessary but is added to demonstrate how to use the EXCI SPI commands.

The final part of section 1 involves issuing a number of container commands to set up container ASCII\_DATA on channel SECOND\_CHANNEL. This is sent again by an **EXEC CICS LINK** request.

### Section 2

Section 2 uses the CALL interface. After **INIT\_USER**, **ALLOCATE\_PIPE**, and **OPEN\_PIPE** have been executed, the DPL section is in a loop that executes twice. It repeats the sending of the containers sent in section 1 but uses the CALL interface instead.

In Section 2, the REQUEST\_TYPE container will contain "CALL1" or "CALL2", not "LINK1" or "LINK2". The other containers will be as sent for Section 1.

### Section 3

Section 3 deletes the channels used. This is not required, but is done to show best practise. Then **CLOSE\_PIPE** and **DEALLOCATE\_PIPE** are executed.

The server program, DFHAXNS (in assembler) is invoked by both DFHAXNC and DFHOCXNC. It uses the contents of the REQUEST\_TYPE container to know whether this is the first or second invocation by either the EXEC or the CALL interface. If the container cannot be found, the program abends with abend code NCON, which indicates that the REQUEST\_TYPE container could not be found. If this succeeds, the server program gets the appropriate container for the indicated request and returns a response in container EXCI\_RESPONSE. This is tested by the client programs to make sure the response contains the text 'OK'. The program writes records to a TS main queue called DFHAXNSQ. This enables execution of the program to be confirmed and shows whether everything worked properly.

The assembler version of the client program is supplied pregenerated in an executable form. Both versions of the program accept two runtime parameters, as follows:

#### **TARGET\_SYSTEM**

Specifies the server region APPLID.

If you use the pregenerated assembler version, you do not need to reassemble the program to specify the APPLID of your own CICS server region. You can also use the sample client programs with different CICS regions without needing to modify the programs each time.

#### **USERID**

Specifies the user ID to be used on the call interface DPL\_request.

You specify these positional parameters on the PARM statement, separated by a comma.

## Setting up the EXCI channel and containers sample programs

---

The sample external CICS interface programs are included on the CICS Transaction Server for z/OS distribution tape. Resource definitions that support the EXCI sample programs are included in the CICS system definition file (CSD) in groups DFH\$EXCI.

### About this task

The sample programs, shown in Table 8 on page 119, are supplied in source form in CICSTS55.CICS.SDFHSAMP. The sample assembler server program is also supplied in executable form in CICSTS55.CICS.SDFHLOAD. The assembler client program is supplied in CICSTS55.CICS.SDFHEXCI.

**Note:** The resource definitions for the EXCI sample programs, while included in the CSD, are not included in the IBM-defined group list DFHLIST. Thus, if CICS is initialized with GRPLIST=DFHLIST, you must install the EXCI resource definition groups before using the samples. Alternatively, you can add the sample groups to your startup group list, so that they are installed automatically at system initialization.

### Procedure

1. Install the following resource definition group:



## DFH\$EXCI

This contains definitions for the sample server transaction, server program, EXCI connections, and sessions.

Only one server program is included—in assembler language, called DFH\$AXNS.

The sample application is designed to run the transaction EXCI, which is defined to invoke the DFHMIRS mirror program and references profile DFHCICSA. The required transaction definition for EXCI is included in the group.

Sample CONNECTION and SESSIONS definitions for specific and generic connections are included.

**Note:** Both the generic and specific connection definitions supplied in the sample group DFH\$EXCI specify ATTACHSEC(IDENTIFY). This security option causes the server program DFH\$AXNS to fail with an ATCY abend if you run the sample programs in an environment that does not have RACF, or an equivalent external security manager (ESM), installed and active.

If you want to run the external CICS interface sample programs without any security active, you must alter the connection resource definitions to specify ATTACHSEC(LOCAL).

2. For transactions that are to be linked to from the batch program, specify the mirror program DFHMIRS as the program name in their transaction definitions.
3. Ensure that interregion communication (IRC) is open.  
If IRC is not opened during CICS initialization, set it open using the **CEMT SET IRC OPEN** command.
4. If you want to use the COBOL version of the EXCI client program, translate, compile, and link-edit the program into a suitable library by using the DFHZXTCL or DFHYXTVL procedure.

## Running the EXCI channel and containers sample applications

You can create a batch job to run the client program. You can also run the client program by using the pregenerated assembler version.

### Before you begin

1. To use the COBOL version of the EXCI client program, you must translate, compile, and link-edit the program into a suitable library by using the DFHZXTCL or DFHYXTVL procedure.
2. The resource definitions for the EXCI sample programs, while included in the CSD, are not included in the IBM-defined group list DFHLIST. Thus, if CICS is initialized with GRPLIST=DFHLIST, you must install the EXCI resource definition groups before using the samples. Alternatively, you can add the sample groups to your startup group list, so that they are installed automatically at system initialization.

### Procedure

- Create a batch job to run the client program, based on the following sample JCL:

```
//EXCI    JOB (accounting_information),CLASS=A,TIME=1440,  
//        USER=userid,PASSWORD=pswd,REGION=100M  
//*****  
//*      JCL to execute an external CICS interface client program  *  
//*****  
//        EXEC   PGM=pgmname,REGION=nnM,MEMLIMIT=nnG  
//STEPLIB DD    DSN=CICSTS54.CICS.EXCI.LOADLIB,DISP=SHR  
//        DD     DSN=CICSTS54.CICS.SDFHEXCI,DISP=SHR  
//SYSPRINT DD   SYSOUT=A  
//SYSMDUMP DD   DSN=SYS1.SYSMDP00,VOL=SER=volid,SPACE=(CYL,(1,1)),  
//        DISP=OLD,UNIT=3390
```

Figure 9. Sample job for starting an EXCI client program

- If you want to use the pregenerated assembler version of the client program, issue the following EXEC statement for the client program:

```
//*****  
//ASM      EXEC  PGM=client_program_name,PARM='applid,userid',REGION=0M,MEMLIMIT=1G
```

where:

**client\_program\_name**

Specify the name of the client program, for example, DFH\$AXNC.

**applid**

Specify the APPLID of your target CICS server region.

**Note:** If you omit *applid*, you must keep the comma that precedes the user ID.

**userid**

Specify the user ID for the DPL\_request call.

## Results

Figure 10 on page 122 shows an example of the output from DFH\$AXNC if the pregenerated assembler version of the client program DFH\$AXNC is executed successfully.

```
***** EXCI Sample Batch Client Program *****  
*                                                                 *  
*   Parameters: APPLID=IYK2Z2G1 ..... *  
*                                                                 *  
* EXEC Level Processor. *  
*   Setting up the EXEC level call. *  
*   The Link Request with channel FIRST_CHANNEL has completed successfully. *  
*   Checking response container sent by server. *  
*   Response OK, continue processing. *  
*   Query channel command completed successfully. *  
*   Correct number of containers returned. *  
*   Browse of channel names completed successfully. *  
*   The Link Request with channel SECOND_CHANNEL has completed successfully. *  
*   Checking response container sent by server. *  
*   Response OK, continue processing. *  
*                                                                 *  
* CALL Level Processor. *  
*   Initialise_User call complete. *  
*   Allocate_Pipe call complete. *  
*   Open_Pipe call complete. *  
*   The connection has been successful. *  
*   Container EBCDIC_DATA was received correctly in channel FIRST_CHANNEL. *  
*   Container ASCII_DATA was received correctly in channel SECOND_CHANNEL. *  
*   Channels have been deleted. *  
*   Close_Pipe call complete. *  
*   Deallocate_Pipe call complete. *  
*                                                                 *  
***** End of EXCI Sample Batch Client Program *****
```

Figure 10. Example output from successful execution of DFH\$AXNC

## Notices

---

This information was developed for products and services offered in the United States of America. This material might be available from IBM in other languages. However, you may be required to own a copy of the product or product version in that language in order to access it.

IBM may not offer the products, services, or features discussed in this document in other countries. Consult your local IBM representative for information on the products and services currently available in your area. Any reference to an IBM product, program, or service is not intended to state or imply that only that IBM product, program, or service may be used. Any functionally equivalent product, program, or service that does not infringe any IBM intellectual property rights may be used instead. However, it is the user's responsibility to evaluate and verify the operation of any non-IBM product, program, or service.

IBM may have patents or pending patent applications covering subject matter described in this document. The furnishing of this document does not grant you any license to these patents. You can send license inquiries, in writing, to:

*IBM Director of Licensing  
IBM Corporation  
North Castle Drive, MD-NC119  
Armonk, NY 10504-1785  
United States of America*

For license inquiries regarding double-byte character set (DBCS) information, contact the IBM Intellectual Property Department in your country or send inquiries, in writing, to:

*Intellectual Property Licensing  
Legal and Intellectual Property Law  
IBM Japan Ltd.  
19-21, Nihonbashi-Hakozakicho, Chuo-ku  
Tokyo 103-8510, Japan*

INTERNATIONAL BUSINESS MACHINES CORPORATION PROVIDES THIS PUBLICATION "AS IS" WITHOUT WARRANTY OF ANY KIND, EITHER EXPRESS OR IMPLIED, INCLUDING, BUT NOT LIMITED TO, THE IMPLIED WARRANTIES OF NON-INFRINGEMENT, MERCHANTABILITY, OR FITNESS FOR A PARTICULAR PURPOSE. Some jurisdictions do not allow disclaimer of express or implied warranties in certain transactions, therefore this statement may not apply to you.

This information could include technical inaccuracies or typographical errors. Changes are periodically made to the information herein; these changes will be incorporated in new editions of the publication. IBM may make improvements and/or changes in the product(s) and/or the program(s) described in this publication at any time without notice.

Any references in this information to non-IBM websites are provided for convenience only and do not in any manner serve as an endorsement of those websites. The materials at those websites are not part of the materials for this IBM product and use of those websites is at your own risk.

IBM may use or distribute any of the information you supply in any way it believes appropriate without incurring any obligation to you.

Licensees of this program who want to have information about it for the purpose of enabling: (i) the exchange of information between independently created programs and other programs (including this one) and (ii) the mutual use of the information which has been exchanged, should contact

*IBM Director of Licensing  
IBM Corporation  
North Castle Drive, MD-NC119 Armonk,  
NY 10504-1785  
United States of America*

Such information may be available, subject to appropriate terms and conditions, including in some cases, payment of a fee.

The licensed program described in this document and all licensed material available for it are provided by IBM under terms of the IBM Client Relationship Agreement, IBM International Programming License Agreement, or any equivalent agreement between us.

The performance data discussed herein is presented as derived under specific operating conditions. Actual results may vary.

Information concerning non-IBM products was obtained from the suppliers of those products, their published announcements or other publicly available sources. IBM has not tested those products and cannot confirm the accuracy of performance, compatibility or any other claims related to non-IBM products. Questions on the capabilities of non-IBM products should be addressed to the suppliers of those products.

This information contains examples of data and reports used in daily business operations. To illustrate them as completely as possible, the examples include the names of individuals, companies, brands, and products. All of these names are fictitious and any similarity to actual people or business enterprises is entirely coincidental.

#### COPYRIGHT LICENSE:

This information contains sample application programs in source language, which illustrate programming techniques on various operating platforms. You may copy, modify, and distribute these sample programs in any form without payment to IBM, for the purposes of developing, using, marketing or distributing application programs conforming to the application programming interface for the operating platform for which the sample programs are written. These examples have not been thoroughly tested under all conditions. IBM, therefore, cannot guarantee or imply reliability, serviceability, or function of these programs. The sample programs are provided "AS IS", without warranty of any kind. IBM shall not be liable for any damages arising out of your use of the sample programs.

## Programming interface information

IBM CICS supplies some documentation that can be considered to be Programming Interfaces, and some documentation that cannot be considered to be a Programming Interface.

Programming Interfaces that allow the customer to write programs to obtain the services of CICS Transaction Server for z/OS, Version 5 Release 5 (CICS TS 5.5) are included in the following sections of the online product documentation:

- [Developing applications](#)
- [Developing system programs](#)
- [CICS security](#)
- [Developing for external interfaces](#)
- [Reference: application development](#)
- [Reference: system programming](#)
- [Reference: connectivity](#)

Information that is NOT intended to be used as a Programming Interface of CICS TS 5.5, but that might be misconstrued as Programming Interfaces, is included in the following sections of the online product documentation:

- [Troubleshooting and support](#)
- [Reference: diagnostics](#)

If you access the CICS documentation in manuals in PDF format, Programming Interfaces that allow the customer to write programs to obtain the services of CICS TS 5.5 are included in the following manuals:

- Application Programming Guide and Application Programming Reference
- Business Transaction Services

- Customization Guide
- C++ OO Class Libraries
- Debugging Tools Interfaces Reference
- Distributed Transaction Programming Guide
- External Interfaces Guide
- Front End Programming Interface Guide
- IMS Database Control Guide
- Installation Guide
- Security Guide
- CICS Transactions
- CICSplex System Manager (CICSplex SM) Managing Workloads
- CICSplex SM Managing Resource Usage
- CICSplex SM Application Programming Guide and Application Programming Reference
- Java™ Applications in CICS

If you access the CICS documentation in manuals in PDF format, information that is NOT intended to be used as a Programming Interface of CICS TS 5.5, but that might be misconstrued as Programming Interfaces, is included in the following manuals:

- Data Areas
- Diagnosis Reference
- Problem Determination Guide
- CICSplex SM Problem Determination Guide

## Trademarks

IBM, the IBM logo, and [ibm.com](http://www.ibm.com)® are trademarks or registered trademarks of International Business Machines Corp., registered in many jurisdictions worldwide. Other product and service names might be trademarks of IBM or other companies. A current list of IBM trademarks is available on the Web at [Copyright and trademark information at www.ibm.com/legal/copytrade.shtml](http://www.ibm.com/legal/copytrade.shtml).

Adobe, the Adobe logo, PostScript, and the PostScript logo are either registered trademarks or trademarks of Adobe Systems Incorporated in the United States, and/or other countries.

Apache, Apache Axis2, Apache Maven, Apache Ivy, the Apache Software Foundation (ASF) logo, and the ASF feather logo are trademarks of Apache Software Foundation.

Gradle and the Gradlephant logo are registered trademark of Gradle, Inc. and its subsidiaries in the United States and/or other countries.

Intel, Intel logo, Intel Inside, Intel Inside logo, Intel Centrino, Intel Centrino logo, Celeron, Intel Xeon, Intel SpeedStep, Itanium, and Pentium are trademarks or registered trademarks of Intel Corporation or its subsidiaries in the United States and other countries.

Java and all Java-based trademarks and logos are trademarks or registered trademarks of Oracle and/or its affiliates.

The registered trademark Linux® is used pursuant to a sublicense from the Linux Foundation, the exclusive licensee of Linus Torvalds, owner of the mark on a worldwide basis.

Microsoft, Windows, Windows NT, and the Windows logo are trademarks of Microsoft Corporation in the United States, other countries, or both.

Red Hat®, and Hibernate® are trademarks or registered trademarks of Red Hat, Inc. or its subsidiaries in the United States and other countries.

Spring Boot is a trademark of Pivotal Software, Inc. in the United States and other countries.

UNIX is a registered trademark of The Open Group in the United States and other countries.  
Zowe™, the Zowe logo and the Open Mainframe Project™ are trademarks of The Linux Foundation.  
The Stack Exchange name and logos are trademarks of Stack Exchange Inc.

## **Terms and conditions for product documentation**

Permissions for the use of these publications are granted subject to the following terms and conditions.

### **Applicability**

These terms and conditions are in addition to any terms of use for the IBM website.

### **Personal use**

You may reproduce these publications for your personal, noncommercial use provided that all proprietary notices are preserved. You may not distribute, display or make derivative work of these publications, or any portion thereof, without the express consent of IBM.

### **Commercial use**

You may reproduce, distribute and display these publications solely within your enterprise provided that all proprietary notices are preserved. You may not make derivative works of these publications, or reproduce, distribute or display these publications or any portion thereof outside your enterprise, without the express consent of IBM.

### **Rights**

Except as expressly granted in this permission, no other permissions, licenses or rights are granted, either express or implied, to the publications or any information, data, software or other intellectual property contained therein.

IBM reserves the right to withdraw the permissions granted herein whenever, in its discretion, the use of the publications is detrimental to its interest or, as determined by IBM, the above instructions are not being properly followed.

You may not download, export or re-export this information except in full compliance with all applicable laws and regulations, including all United States export laws and regulations.

IBM MAKES NO GUARANTEE ABOUT THE CONTENT OF THESE PUBLICATIONS. THE PUBLICATIONS ARE PROVIDED "AS-IS" AND WITHOUT WARRANTY OF ANY KIND, EITHER EXPRESSED OR IMPLIED, INCLUDING BUT NOT LIMITED TO IMPLIED WARRANTIES OF MERCHANTABILITY, NON-INFRINGEMENT, AND FITNESS FOR A PARTICULAR PURPOSE.

## **IBM online privacy statement**

IBM Software products, including software as a service solutions, (*Software Offerings*) may use cookies or other technologies to collect product usage information, to help improve the end user experience, to tailor interactions with the end user or for other purposes. In many cases no personally identifiable information (PII) is collected by the Software Offerings. Some of our Software Offerings can help enable you to collect PII. If this Software Offering uses cookies to collect PII, specific information about this offering's use of cookies is set forth below:

### **For the CICSplex SM Web User Interface (main interface):**

Depending upon the configurations deployed, this Software Offering may use session and persistent cookies that collect each user's user name and other PII for purposes of session management, authentication, enhanced user usability, or other usage tracking or functional purposes. These cookies cannot be disabled.

### **For the CICSplex SM Web User Interface (data interface):**

Depending upon the configurations deployed, this Software Offering may use session cookies that collect each user's user name and other PII for purposes of session management, authentication, or other usage tracking or functional purposes. These cookies cannot be disabled.

### **For the CICSplex SM Web User Interface ("hello world" page):**

Depending upon the configurations deployed, this Software Offering may use session cookies that do not collect PII. These cookies cannot be disabled.

**For CICS Explorer®:**

Depending upon the configurations deployed, this Software Offering may use session and persistent preferences that collect each user's user name and password, for purposes of session management, authentication, and single sign-on configuration. These preferences cannot be disabled, although storing a user's password on disk in encrypted form can only be enabled by the user's explicit action to check a check box during sign-on.

If the configurations deployed for this Software Offering provide you, as customer, the ability to collect PII from end users via cookies and other technologies, you should seek your own legal advice about any laws applicable to such data collection, including any requirements for notice and consent.

For more information about the use of various technologies, including cookies, for these purposes, see [IBM Privacy Policy](#) and [IBM Online Privacy Statement](#), the section entitled *Cookies, Web Beacons and Other Technologies* and the [IBM Software Products and Software-as-a-Service Privacy Statement](#).





# Index

## Special Characters

- > 32K COMMAREAs (channels)
  - DELETE CHANNEL (EXCI) command [42](#)
  - DELETE CONTAINER (EXCI) command [43](#)
  - ENDBROWSE CONTAINER (EXCI) command [44](#)
  - GET CONTAINER (EXCI) command [45](#)
  - GETNEXT CONTAINER (EXCI) command [49](#)
  - MOVE CONTAINER (EXCI) command [50](#)
  - PUT CONTAINER (EXCI) command [52](#)
  - QUERY CHANNEL (EXCI) command [55](#)
  - STARTBROWSE CONTAINER (EXCI) command [56](#)

## Numerics

- 2-phase commit
  - DPL\_Request [8](#)
  - protocol invoked by RRS [8](#)

## A

- addressing mode (AMODE)
  - client program requirements [57](#)
- allocate\_opts, parameter of ALLOCATE\_PIPE command [16](#)
- Allocate\_Pipe command [15](#)
- ALLOCATE\_PIPE command
  - invocation of DFHXCURM during [66](#)
  - security check failure [73](#)
- allocating a pipe [15](#)
- APPEND option
  - PUT CONTAINER (EXCI) command [52](#)
- application programming
  - commands [11](#)
  - copybooks [32](#)
  - DPL subset [4](#)
  - exception conditions returned on LINK command [37](#)
  - language considerations [59](#)
  - RESP and RESP2 fields [37](#)
  - restrictions for server programs [4](#)
  - stub [57](#)
  - translation required for EXEC CICS LINK command [41](#)
- applid, specifying on ALLOCATE\_PIPE command [16](#)
- AS option
  - MOVE CONTAINER (EXCI) command [50](#)
- assembler
  - CICS-supplied procedure, DFHEXTAL [59](#)
  - copybook [32](#)
  - EXCI CALL interface [11](#)
  - sample program [34](#)
- automatic retry of EXEC CICS LINK [38](#)

## B

- batch jobs, querying the status of [65](#)
- benefits of external CICS interface [1](#)
- big COMMAREAs (channels)

- big COMMAREAs (channels) (*continued*)
  - DELETE CHANNEL (EXCI) command [42](#)
  - DELETE CONTAINER (EXCI) command [43](#)
  - QUERY CHANNEL (EXCI) command [55](#)
- big COMMAREAs, channels [42–45](#), [49](#), [50](#), [52](#), [55](#), [56](#)
- bind-time security [73](#)
- BROWSETOKEN option
  - ENDBROWSE CONTAINER (CHANNEL) command [44](#)
  - GETNEXT CONTAINER (EXCI) command [49](#)
  - STARTBROWSE CONTAINER command [56](#)
- BYTEOFFSET option
  - GET CONTAINER (EXCI) command [45](#)

## C

- C language
  - CICS-supplied procedure, DFHYXTDL [59](#)
  - CICS-supplied procedure, DFHYXTEL [59](#)
  - copybook [32](#)
  - EXCI CALL interface [11](#)
  - sample program [34](#)
  - special considerations for client program [59](#)
- C versions
  - DFHZXTDL [59](#)
- C++
  - CICS-supplied procedure, DFHZXTEL [59](#)
- call\_type
  - parameter of ALLOCATE\_PIPE command [16](#)
  - parameter of CLOSE\_PIPE command [28](#)
  - parameter of DEALLOCATE\_PIPE command [30](#)
  - parameter of DPL\_Request command [20](#)
  - parameter of INITIALIZE\_USER command [12](#)
  - parameter of OPEN\_PIPE command [18](#)
- capturing dumps [78](#)
- CCSID option
  - GET CONTAINER (EXCI) command [45](#)
- ccsid, parameter of DPL\_Request command [25](#)
- CCSIDERR condition
  - GET CONTAINER (EXCI) command [47](#)
  - PUT CONTAINER (EXCI) command [54](#)
- CEMT INQUIRE EXCI command [65](#)
- channel commands
  - DELETE CHANNEL (EXCI) [42](#)
  - DELETE CONTAINER (EXCI) [43](#)
  - ENDBROWSE CONTAINER (EXCI) [44](#)
  - GET CONTAINER (EXCI) [45](#)
  - GETNEXT CONTAINER (EXCI) [49](#)
  - MOVE CONTAINER (EXCI) [50](#)
  - PUT CONTAINER (EXCI) [52](#)
  - QUERY CHANNEL (EXCI) [55](#)
  - STARTBROWSE CONTAINER (EXCI) [56](#)
- CHANNEL option
  - DELETE CHANNEL command [42](#)
  - DELETE CONTAINER (EXCI) command [43](#)
  - GET CONTAINER (EXCI) command [45](#)
  - MOVE CONTAINER (EXCI) command [50](#)
  - PUT CONTAINER (EXCI) command [52](#)

- CHANNEL option (*continued*)
  - QUERY CHANNEL command [55](#)
- CHANNELERR condition
  - DELETE CHANNEL (EXCI) command [42](#)
  - DELETE CONTAINER (EXCI) command [43](#)
  - GET CONTAINER (EXCI) command [48](#)
  - MOVE CONTAINER (EXCI) command [51](#)
  - PUT CONTAINER (EXCI) command [54](#)
  - QUERY CHANNEL command [56](#)
- channels as large COMMAREAs [42–45](#), [49](#), [50](#), [52](#), [55](#), [56](#)
- CICS system initialization parameters
  - IRCSTRT [96](#)
- CICS\_applid, parameter of ALLOCATE\_PIPE command [16](#)
- CICSSVC, parameter of DFHXCOPT [69](#)
- client program
  - addressing mode [57](#)
  - compiling [59](#)
  - definition of [3](#)
  - JCL needed
    - capturing SYSDUMPs [78](#)
    - running an EXCI client [57](#)
  - link-editing [59](#)
  - linking to server with EXEC CICS LINK [35](#)
  - MRO logon and bind-time security [73](#)
  - PL/I and C language considerations [59](#)
  - sample job for starting [58](#)
  - translating [41](#), [59](#)
  - use of multiple sessions [3](#)
- Close\_Pipe command [28](#)
- closing a pipe [28](#)
- COBOL
  - CICS-supplied procedure, DFHYXTVL [59](#)
  - CICS-supplied procedure, DFHZXTCL [59](#)
  - copybook [32](#)
  - example of EXCI DPL call [33](#)
  - EXCI CALL interface [11](#)
- CODEPAGEERR condition
  - GET CONTAINER (EXCI) command [48](#)
  - PUT CONTAINER (EXCI) command [54](#)
- COMMAREA\_len, parameter of DPL\_Request command [20](#)
- COMMAREA, parameter of DPL\_Request command [20](#)
- CONFDATA, parameter of DFHXCOPT [69](#)
- connecting an allocated pipe [17](#)
- CONNECTION definition
  - CONNTYPE attribute [62](#)
  - PROTOCOL attribute [63](#)
- CONNTYPE attribute, CONNECTION definition [62](#)
- container commands
  - DELETE CHANNEL (EXCI) [42](#)
  - DELETE CONTAINER (EXCI) [43](#)
  - ENDBROWSE CONTAINER (EXCI) [44](#)
  - GET CONTAINER (EXCI) [45](#)
  - GETNEXT CONTAINER (EXCI) [49](#)
  - MOVE CONTAINER (EXCI) [50](#)
  - PUT CONTAINER (EXCI) [52](#)
  - QUERY CHANNEL (EXCI) [55](#)
  - STARTBROWSE CONTAINER (EXCI) [56](#)
- CONTAINER option
  - DELETE CONTAINER (EXCI) command [43](#)
  - GET CONTAINER (EXCI) command [45](#)
  - GETNEXT CONTAINER command (EXCI) [49](#)
  - MOVE CONTAINER (EXCI) command [51](#)
  - PUT CONTAINER (EXCI) command [53](#)
- CONTAINERCNT option
  - QUERY CHANNEL command [56](#)
- CONTAINERERR condition
  - DELETE CONTAINER (EXCI) command [44](#)
  - GET CONTAINER (EXCI) command [48](#)
  - MOVE CONTAINER (EXCI) command [51](#)
  - PUT CONTAINER (EXCI) command [55](#)
- CONVERTST option
  - GET CONTAINER (EXCI) command [45](#)
- copybooks for assembler, C language, COBOL, PL/I [32](#)
- cross-system multiregion operation (XCF/MRO) [3](#)
- CSMI
  - attached by CICS server [37](#)
- CSMI (CICS-supplied mirror transaction)
  - authorizing the link user ID [74](#)
  - default transid [22](#)
  - security [74](#)
- CVDA values
  - NOCONVERT
    - GET CONTAINER (EXCI) command [45](#)

## D

- data\_len, parameter of DPL\_Request command [21](#)
- DATATYPE option
  - PUT CONTAINER (EXCI) command [53](#)
- Deallocate\_Pipe command [29](#)
- deallocating a pipe [29](#)
- DELETE CHANNEL (EXCI) command [42](#)
- DELETE CONTAINER (EXCI) command [43](#)
- DFHAXCC, assembler sample program [34](#)
- DFHDXCC, sample program [34](#)
- DFHPXCC, PL/I sample program [34](#)
- DFHAPPL FACILITY class profiles, defining [73](#)
- DFHAUPL procedure [68](#)
- DFHEXTAL, procedure for assembler client programs [59](#)
- DFHIRP (interregion communication program)
  - security checks performed by [73](#)
- DFHXCIE, alias for DFHCSTB stub [57](#)
- DFHXCIS, alias for DFHCSTB stub [57](#)
- DFHXCPLD, return area and equate copybook for assembler [32](#)
- DFHXCPLH, return area and equate copybook for C language [32](#)
- DFHXCPLL, return area and equate copybook for PL/I [32](#)
- DFHXCPLQ, return area and equate copybook for COBOL [32](#)
- DFHXCRCO, return code copybook for assembler [33](#)
- DFHXCRCR, return code copybook for C language [33](#)
- DFHXCRCRCL, return code copybook for PL/I [33](#)
- DFHXCRCO, return code copybook for COBOL [33](#)
- DFHXCSTB, stub for client programs [57](#)
- DFHXCTRA, EXCI service trap [78](#)
- DFHXCTRD, parameter list [79](#)
- DFHXCURM, user-replaceable module [66](#)
- DFHYXTDL, procedure for client programs [59](#)
- DFHYXTEL, procedure for ++ client programs [59](#)
- DFHYXTPL, procedure for PL/I client programs [59](#)
- DFHYXTVL, procedure for COBOL client programs [59](#)
- DFHZXTCL, procedure for COBOL client programs [59](#)
- DFHZXTDL, procedure for C client programs [59](#)
- DFHZXTEL, procedure for C++ client programs [59](#)
- DFHZXTPL, procedure for PL/I client programs [59](#)
- disconnecting a pipe [28](#)
- distributed program link (DPL)

distributed program link (DPL) (*continued*)  
API subset for server programs [4](#)  
example COBOL call without userid and uowid [33](#)  
request program call [19](#)  
DPL\_opts, parameter of DPL\_Request command [24](#)  
DPL\_Request call [19](#)  
dpl\_retarea, parameter of DPL\_Request command [23](#)  
dumps  
formatting [77](#)  
SYSMDUMP [78](#)  
DURETRY, parameter of DFHXCOPT [70](#)  
dynamic routing  
EXCI [61](#)

## E

END condition  
GETNEXT CONTAINER (CHANNEL) command [49](#)  
ENDBROWSE CONTAINER (EXCI) command [44](#)  
endian, parameter of DPL\_Request command [25](#)  
EQUATE copybooks [32](#)  
exception conditions returned on LINK command [37](#)  
EXCI  
dynamic routing [61](#)  
static routing [61](#)  
EXCI on CEMT INQUIRE command [65](#)  
EXEC CICS LINK command  
automatic retry [38](#)  
choosing between EXEC CICS and CALL interface [5](#)  
DFHAPPL profile definition [74](#)  
security checking [74](#)  
translation [41](#)  
external CICS interface (EXCI)  
benefits [1](#)  
CALL interface  
choosing between EXEC CICS and CALL interface [5](#)  
DFHAPPL profile definition [74](#)  
return area [32](#)  
syntax [11](#)  
compiling and link-editing client programs [57](#)  
defining connections [62](#)  
description of [3](#)  
inquiring on the state of connections [65](#)  
languages supported [11](#)  
PL/I and C language considerations [59](#)  
problem determination [77](#)  
programming languages supported [11](#)  
reason codes [93](#)  
resource and recovery [8](#)  
response codes [93](#)  
security [73](#)  
taking a syncpoint in the client program [11](#)  
user-replaceable module (DFHXCURM) [66](#)  
using RRMS [8](#)

## F

FACILITY class profiles, defining [73](#)  
FLENGTH option  
GET CONTAINER (EXCI) command [46](#)  
PUT CONTAINER (EXCI) command [53](#)  
freeing storage associated with a pipe [29](#)  
FROM option

FROM option (*continued*)  
PUT CONTAINER (EXCI) command [53](#)  
FROMCCSID option  
PUT CONTAINER (EXCI) command [53](#)  
FROMCODEPAGE option  
GET CONTAINER (EXCI) command [53](#)  
function call EQUATE copybooks [32](#)

## G

generic connection  
definition of [63](#)  
note about lack of security checks [73](#)  
GET CONTAINER (EXCI) command [45](#)  
GETNEXT CONTAINER (EXCI) command [49](#)  
GTF, parameter of DFHXCOPT [70](#)

## I

Initialize\_User command [12](#)  
INTO option  
GET CONTAINER (EXCI) command [46](#)  
INTOCCSID option  
GET CONTAINER (EXCI) command [46](#)  
INTOCODEPAGE option  
GET CONTAINER (EXCI) command [46](#)  
INVREQ condition  
DELETE CONTAINER (EXCI) command [44](#)  
GET CONTAINER (EXCI) command [48](#)  
MOVE CONTAINER (EXCI) command [51](#)  
PUT CONTAINER (EXCI) command [55](#)  
IRCSTRT system initialization parameter [96](#)

## J

job control language (JCL)  
for capturing SYSMDUMPs [78](#)  
for running an EXCI client program [57](#)

## L

large COMMAREAs, channels [42–45](#), [49](#), [50](#), [52](#), [55](#), [56](#)  
LENGERR condition  
GET CONTAINER (EXCI) command [48](#)  
PUT CONTAINER (EXCI) command [55](#)  
LINK command  
choosing between EXEC CICS and CALL interface [5](#)  
link-editing  
DFHXCOPT options table [68](#)  
for client program [57](#)  
translation required for EXEC CICS LINK command [41](#)  
use of DFHXCSTB stub [11](#)  
using DFHAUPLE [68](#)  
logon security [73](#)

## M

MOVE CONTAINER (EXCI) command [50](#)  
MSGCASE, parameter of DFHXCOPT [70](#)  
multiregion operation (MRO)  
cross-system (XCF/MRO) [3](#)  
logon and bind time security [73](#)

## N

NODATA option  
GET CONTAINER (EXCI) command [47](#)  
null parameters, example of EXCI CALLs with [33](#)

## O

open system interface (OSI) [1](#)  
Open\_Pipe command [17](#)  
opening a pipe [17](#)  
OSI (open system interface) [1](#)

## P

parameters  
null [33](#)  
pgmname  
parameter of DPL\_Request command [20](#)  
pipe  
allocating [15](#)  
closing [28](#)  
connecting [17](#)  
deallocating [29](#)  
definition of [3](#)  
disconnecting [28](#)  
freeing storage associated with [29](#)  
invocation of DFHXCURM during ALLOCATE\_PIPE [66](#)  
opening [17](#)  
restriction on leaving open [17](#)  
reusing a closed pipe [28](#)  
pipe\_token  
parameter of ALLOCATE\_PIPE command [16](#)  
parameter of CLOSE\_PIPE command [29](#)  
parameter of DEALLOCATE\_PIPE command [30](#)  
parameter of DPL\_Request command [20](#)  
parameter of OPEN\_PIPE command [18](#)  
PL/I  
CICS-supplied procedure, DFHYXTPL [59](#)  
CICS-supplied procedure, DFHZXTPL [59](#)  
copybook [32](#)  
EXCI CALL interface [11](#)  
sample program [34](#)  
special considerations for client program [59](#)  
plus 32K COMMAREAs (channels)  
DELETE CHANNEL (EXCI) command [42](#)  
DELETE CONTAINER (EXCI) command [43](#)  
ENDBROWSE CONTAINER (EXCI) command [44](#)  
GET CONTAINER (EXCI) command [45](#)  
GETNEXT CONTAINER (EXCI) command [49](#)  
MOVE CONTAINER (EXCI) command [50](#)  
PUT CONTAINER (EXCI) command [52](#)  
QUERY CHANNEL (EXCI) command [55](#)  
STARTBROWSE CONTAINER (EXCI) command [56](#)  
problem determination  
dumps [77](#)  
service trap [78](#)  
trace [77](#)  
programming restrictions for server programs [4](#)  
PROTOCOL attribute  
CONNECTION definition [63](#)  
SESSIONS definition [63](#)  
PUT CONTAINER (EXCI) command [52](#)

## Q

QUERY CHANNEL (EXCI) command [55](#)

## R

reason codes  
Allocate\_Pipe call [16](#)  
Close\_Pipe call [29](#)  
Deallocate\_Pipe call [30](#)  
DPL call [26](#)  
Initialize\_User call [12](#)  
Open\_Pipe call [18](#)  
RECEIVECOUNT attribute, SESSIONS definition [64](#)  
RECEIVEPFX attribute, SESSIONS definition [64](#)  
resource access control facility (RACF)  
specifying userid on DPL\_Request command [23](#)  
resource definition  
CONNECTION definition [62](#)  
SESSIONS definition [63](#)  
resource recovery services (RRS)  
2-phase commit protocol [8](#)  
RESP and RESP2 fields [37](#)  
response codes  
Allocate\_Pipe call [16](#)  
Close\_Pipe call [29](#)  
Deallocate\_Pipe call [30](#)  
DPL call [26](#)  
Initialize\_User call [12](#)  
Open\_Pipe call [18](#)  
retries on an EXEC CICS LINK command [38](#)  
return code  
clearing R15 [60](#)  
return\_area  
parameter of ALLOCATE\_PIPE command [16](#)  
parameter of CLOSE\_PIPE command [28](#)  
parameter of DEALLOCATE\_PIPE command [30](#)  
parameter of DPL\_Request command [20](#)  
parameter of INITIALIZE\_USER command [12](#)  
parameter of OPEN\_PIPE command [18](#)  
reusing a closed pipe [28](#)  
RRMS  
used by external CICS interface (EXCI) [8](#)

## S

sample programs [34](#)  
security [73](#)  
SENDCOUNT attribute, SESSIONS definition [64](#)  
SENDPFX attribute, SESSIONS definition [65](#)  
server program  
API restrictions [4](#)  
definition of [3](#)  
DPL subset [4](#)  
linking from client with EXEC CICS LINK [35](#)  
programming restrictions [4](#)  
security considerations [73](#)  
service trap [78](#)  
SESSIONS definition  
PROTOCOL attribute [63](#)  
RECEIVECOUNT attribute [64](#)  
RECEIVEPFX attribute [64](#)  
SENDCOUNT attribute [64](#)

SESSIONS definition (*continued*)  
SENDPFX attribute [65](#)  
SET option  
GET CONTAINER (EXCI) command [47](#)  
specific connection  
definition of [62](#)  
MRO logon security checks [73](#)  
STARTBROWSE CONTAINER (EXCI) command [56](#)  
static routing  
EXCI [61](#)  
storage, freeing [29](#)  
stub for client programs  
DFHXCIE [57](#)  
DFHXCIS [57](#)  
DFHXCSTB [57](#)  
suppressing user data in trace  
CONFDATA option [69](#)  
SYNCONRETURN  
DPL requests [8](#)  
omitted by DPL\_Request [8](#)  
SYSMDUMPs, capturing [78](#)  
sysplex, use of cross-system MRO [3](#)

## T

TIMEOUT, parameter of DFHXCOPT [71](#)  
TOCHANNEL option  
MOVE CONTAINER (EXCI) command [51](#)  
TOKENERR condition  
ENDBROWSE CONTAINER (CHANNEL) command [44](#)  
GETNEXT CONTAINER (CHANNEL) command [49](#)  
trace  
TRACE parameter of DFHXCOPT [71](#)  
trace points [79](#)  
TRACESIZE parameter of DFHXCOPT [71](#)  
transid, parameter of DPL\_Request command [21](#)  
transid2, parameter of DPL\_Request command [25](#)  
translation of EXEC CICS LINK command [41](#)  
trap, DFHXCTRA  
TRAP, parameter of DFHXCOPT [71](#)  
TYPE, parameter of DFHXCOPT [69](#)

## U

unit-of-work identifier, DPL\_Request [22](#)  
uowid, parameter of DPL\_Request [22](#)  
user environment, initializing [12](#)  
user security [74](#)  
user\_name, parameter of INITIALIZE\_USER command [12](#)  
user\_token  
parameter of ALLOCATE\_PIPE command [16](#)  
parameter of CLOSE\_PIPE command [28](#)  
parameter of DEALLOCATE\_PIPE command [30](#)  
parameter of DPL\_Request command [20](#)  
parameter of INITIALIZE\_USER command [12](#)  
parameter of OPEN\_PIPE command [18](#)  
user-replaceable module  
DFHXCURM [66](#)  
userid, parameter of DPL\_Request command [23](#)

## V

version\_number

version\_number (*continued*)  
parameter of ALLOCATE\_PIPE command [16](#)  
parameter of CLOSE\_PIPE command [28](#)  
parameter of DEALLOCATE\_PIPE command [30](#)  
parameter of DPL\_Request command [20](#)  
parameter of INITIALIZE\_USER command [12](#)  
parameter of OPEN\_PIPE command [18](#)

## X

XCFGROUP, parameter of DFHXCOPT [72](#)





