

IBM Z Workload Scheduler



# Quick Reference

*Version 9 Release 5*



IBM Z Workload Scheduler

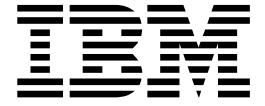

# Quick Reference

*Version 9 Release 5*

**Note**

Before using this information and the product it supports, read the information in "Notices" on page 43.

This edition applies to version 9, release 5, modification level 0 of IBM Workload Scheduler (program number 5698-WSH) and to all subsequent releases and modifications until otherwise indicated in new editions.

© **Copyright IBM Corporation 1999, 2016.**

US Government Users Restricted Rights – Use, duplication or disclosure restricted by GSA ADP Schedule Contract with IBM Corp.

---

# Contents

<b>Figures</b> . . . . .	<b>v</b>	Usage notes . . . . .	25
<b>About this publication</b> . . . . .	<b>vii</b>	SETVAR directive . . . . .	26
Support information . . . . .	vii	Usage notes . . . . .	26
<b>Chapter 1. Using the ISPF dialogs</b> . . . . .	<b>1</b>	BEGIN and END directives . . . . .	26
Specifying list criteria . . . . .	1	FETCH directive. . . . .	26
Using generic search arguments . . . . .	2	COMP keyword on BEGIN and FETCH directives . . . . .	27
Sorting list output . . . . .	2	Usage notes . . . . .	27
Locating data strings in list output . . . . .	2	<b>Chapter 6. Supplied JCL variables</b> . . . . .	<b>29</b>
Graphically displaying lists . . . . .	2	Occurrence-related JCL variables . . . . .	29
PF key assignment . . . . .	3	Operation-related JCL variables. . . . .	30
<b>Chapter 2. TSO commands</b> . . . . .	<b>5</b>	Date-related JCL variables . . . . .	30
BACKUP . . . . .	5	Dynamic-format supplied variables . . . . .	31
BULKDISC . . . . .	5	<b>Chapter 7. Codes</b> . . . . .	<b>33</b>
JSUACT . . . . .	5	Operation status codes . . . . .	33
OPINFO. . . . .	6	Extended status codes . . . . .	33
OPSTAT . . . . .	6	Error codes . . . . .	34
SRSTAT . . . . .	7	Job log retrieval status codes . . . . .	37
WSSTAT. . . . .	7	Operation reason codes . . . . .	37
<b>Chapter 3. Commands to control the scheduler</b> . . . . .	<b>9</b>	<b>Chapter 8. Free-day rule</b> . . . . .	<b>39</b>
Starting the scheduler . . . . .	9	<b>Chapter 9. Defining day to day workload</b> . . . . .	<b>41</b>
Stopping the scheduler . . . . .	9	Job related. . . . .	41
Canceling the scheduler . . . . .	10	NOERROR syntax for JCL return code management . . . . .	41
Modifying the scheduler . . . . .	10	USRREC syntax for end-to-end scheduling . . . . .	41
Modifying the data store . . . . .	19	Modeling related for end-to-end scheduling . . . . .	41
<b>Chapter 4. Automatic recovery</b> . . . . .	<b>23</b>	CPUREC . . . . .	41
RECOVER statement . . . . .	23	DOMREC . . . . .	42
<b>Chapter 5. JCL directives</b> . . . . .	<b>25</b>	<b>Notices</b> . . . . .	<b>43</b>
NOP directive . . . . .	25	Trademarks . . . . .	45
SCAN directive . . . . .	25	Terms and conditions for product documentation. . . . .	45
SEARCH directive . . . . .	25	<b>Index</b> . . . . .	<b>47</b>
TABLE directive . . . . .	25		
SETFORM directive. . . . .	25		



---

## Figures

1. EQQSOPFP - Selecting Operations . . . . . 1





---

## About this publication

*IBM Z Workload Scheduler: Quick Reference* is a handy guide to the more commonly used dialogs, commands, and directives of IBM Z Workload Scheduler.

The term *scheduler*, when used in this publication, refers to IBM Z Workload Scheduler. The term DB2<sup>®</sup>, when used in this publication, refers to DATABASE 2 and DB2 Universal Database<sup>™</sup>.

The term z/OS<sup>®</sup> is used in this publication to mean z/OS and OS/390<sup>®</sup> operating systems. Where the term OS/390 appears, the related information applies only to OS/390 operating systems.

---

## Support information

IBM provides several ways for you to obtain support when you encounter a problem.

If you have a problem with your IBM software, you want to resolve it quickly. IBM provides the following ways for you to obtain the support you need:

- Searching knowledge bases: You can search across a large collection of known problems and workarounds, Technotes, and other information.
- Obtaining fixes: You can locate the latest fixes that are already available for your product.
- Contacting IBM Software Support: If you still cannot solve your problem, and you need to work with someone from IBM, you can use a variety of ways to contact IBM Software Support.

For more information about these three ways of resolving problems, see the appendix about support information in *IBM Workload Scheduler: Troubleshooting Guide*.



# Chapter 1. Using the ISPF dialogs

Table 1. Some primary commands for panels

Command	Action
RETURN	Return to main menu. An end operation is run for each panel in the sequence leading back to the main menu (all changes on the individual panels are saved).
CANCEL	Return to the previous panel without making any changes.
RIGHT	Display the right part of the data. This is available only from panels that have the text LEFT PART in the panel title.
LEFT	Display the left part of the data. This is available only from panels that have the text RIGHT PART in the panel title.
HELP	Display help information.
SORT	Sort information in a list.
LOCATE <i>lparm</i>	Scroll to the field specified. If the field is not found, the list is displayed starting with the entry before which the specified field would have occurred. If the list is sorted by application name, <i>lparm</i> is the name of the application; if sorted by job name, <i>lparm</i> is a job name.
GRAPH	Display a network of dependencies.
GDDM	Execute Graphical Data Display Manager (GDDM) functions on a graphically displayed network.
ATTR	Set graphic attributes.

## Specifying list criteria

Limit the length of lists by using filter panels like the SELECTING OPERATIONS panel:

```

EQQSOPFP ----- SELECTING OPERATIONS -----
Command ==>>

Specify selection criteria below and press ENTER to create an operation list.

JOBNAME          => P*_____   WORK STATION NAME => _____
APPLICATION ID   => _____   OWNER ID          => _____
AUTHORITY GROUP => _____   PRIORITY         => _____
GROUP DEFINITION => _____   STATUS           => _____
CLEAN UP TYPE    => _____   CLEAN UP RESULT  => _____
OP. EXTENDED NAME => _____
OP. SE NAME      => _____
Input arrival in format YY/MM/DD HH.MM
FROM             => _____
TO              => _____

Additional Options ( Y N )
FAST PATH        => Y           Valid only along with jobname
MANUALLY HELD    => -
WAITING FOR SE   => -           Leave blank to select all
STARTED ON WAIT WS => -       Leave blank to select all
  
```

Figure 1. EQQSOPFP - Selecting Operations

You can use blanks, complete names, IDs, or search arguments in the input fields.

On some selection panels you can choose the *fastpath* option, so that IBM Z Workload Scheduler searches for matching job names on automatic workstations. If there is a matching job name, IBM Z Workload Scheduler includes all operations with that job name, whether on an automatic workstation or not.

---

## Using generic search arguments

Many of the input fields in the dialog accept generic search arguments. Use an asterisk (\*) to represent any character string or a null string. Use a percent sign (%) for any single character.

To select all application identifiers whose first three letters are PAY, enter this in the input field:

```
APPLICATION ID ==> PAY*_____
```

To select all applications where P is the first letter and Y is the third letter, enter this:

```
APPLICATION ID ==> P%Y*_____
```

---

## Sorting list output

In all list displays, enter the SORT command to display a panel where you can specify the order of the list items. The sort order you request remains in effect for that specific list type until changed.

If you sort on date fields, take into account the date format that has been specified, because this can affect the order.

---

## Locating data strings in list output

Enter LOCATE on any list display panel to find a data string in the list. The command also supports generic search strings. For example, you can enter LOCATE ABC\* to find any item in the list beginning with ABC. Locate scrolls to the field specified.

If the list is sorted by application name, request LOCATE applname; similarly, if sorted by job name, request LOCATE jobname. If you need to issue a locate command on a list that is not sorted by the item you want to locate, change the order with the SORT command.

---

## Graphically displaying lists

If you have GDDM installed and have a terminal capable of displaying graphics, you can also display lists of applications, occurrences, and operations graphically. Graphic displays contain the same information as edit or selection lists, but the format is different; you can see dependency connections that might be hard to see from a conventional list.

To see a graphically displayed list, enter GRAPH at the command prompt of a panel on which graph is an option.

---

## PF key assignment

The dialog maintains separate program function (PF) keys from your normal ISPF key assignments. Enter KEYS at the command prompt to display or change the current assignment.

You can define PF keys to run a command that you use regularly, for example, to display the ready list. To ensure that the command will be run correctly, regardless of the panel it is entered from, define the PF key like this:

```
PF5  ==> ;=4.1.cpu1
```

Where ; is your ISPF command delimiter.

You can define unique PF key assignments for different panels. For example, if you regularly use the application description dialog, you can define PF keys for the OPER and RUN commands.

It is recommended that you do not alter the key assignments for PF1 (HELP), or PF12 (RETRIEVE). The retrieve PF key returns the command you last run to the command prompt. A stack of approximately 25 commands is maintained.

The PF KEY DEFINITIONS AND LABELS panel lets you assign labels to the PF key definitions. When you enter the PFSHOW command from a panel, the PF key labels are displayed. To remove the display, enter PFSHOW OFF.



---

## Chapter 2. TSO commands

This chapter describes the syntax for the IBM Z Workload Scheduler TSO commands, BACKUP, BULKDISC, JSUACT, OPINFO, OPSTAT, SRSTAT, and WSTAT.

You can abbreviate keywords to their shortest unambiguous form. For example, you can shorten the AVAIL keyword to an 'A'. Before you invoke an IBM Z Workload Scheduler TSO command, you must allocate the EQQLIB data set to the TSO address space, either by adding DD statements to the logon procedure, or by using the ALLOC command after TSO logon. Error messages are sent directly to the terminal.

The TSO commands can be directed to a specific IBM Z Workload Scheduler subsystem (tracker). The tracker does not have to be active when you issue the command. An event is generated and queued in ECSA along with other job-tracking events.

---

### BACKUP

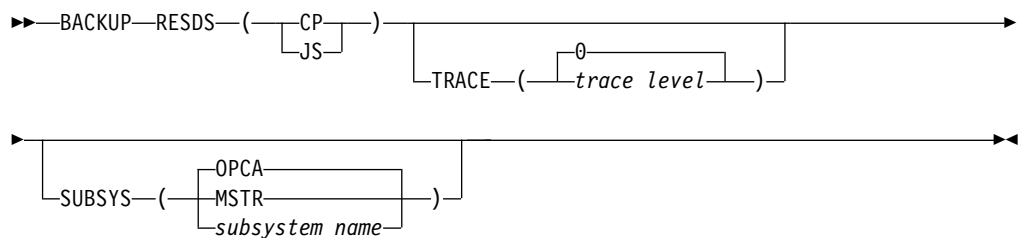

---

### BULKDISC

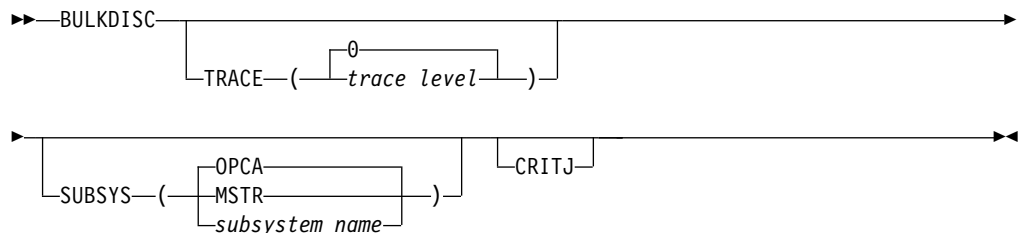

---

### JSUACT

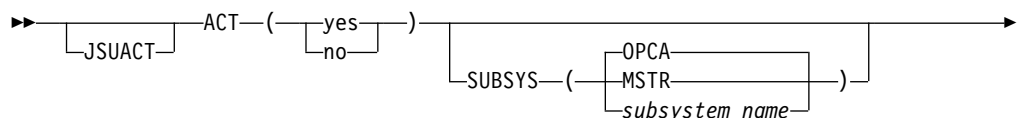

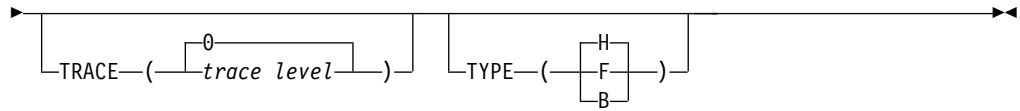

## OPINFO

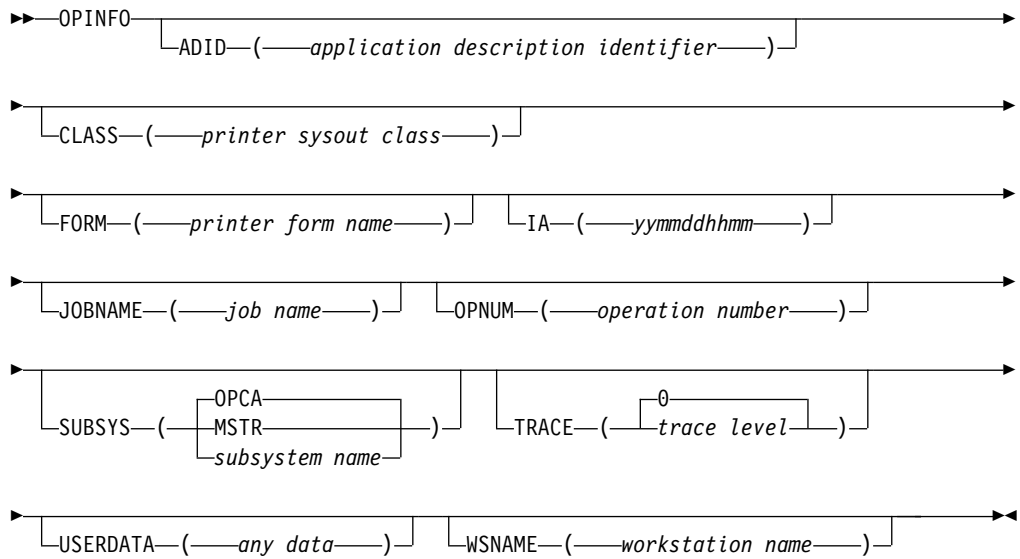

## OPSTAT

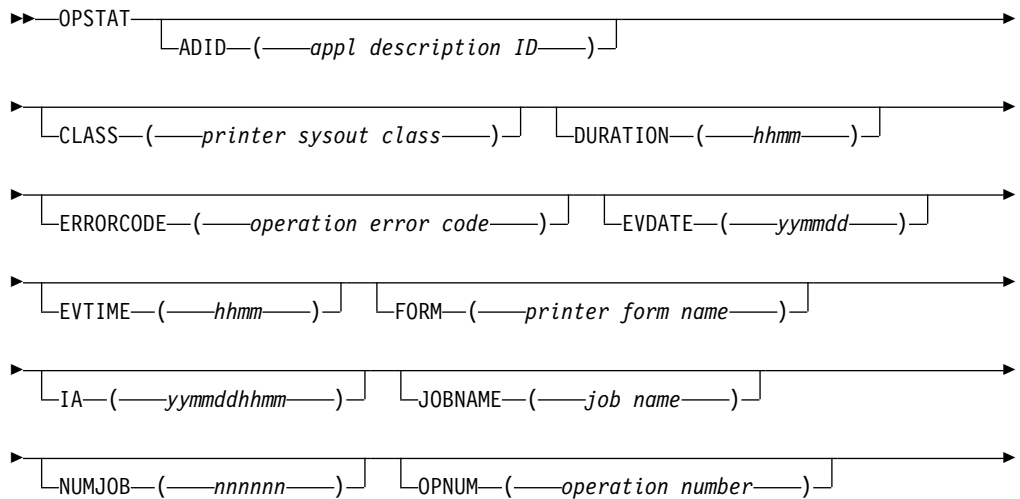



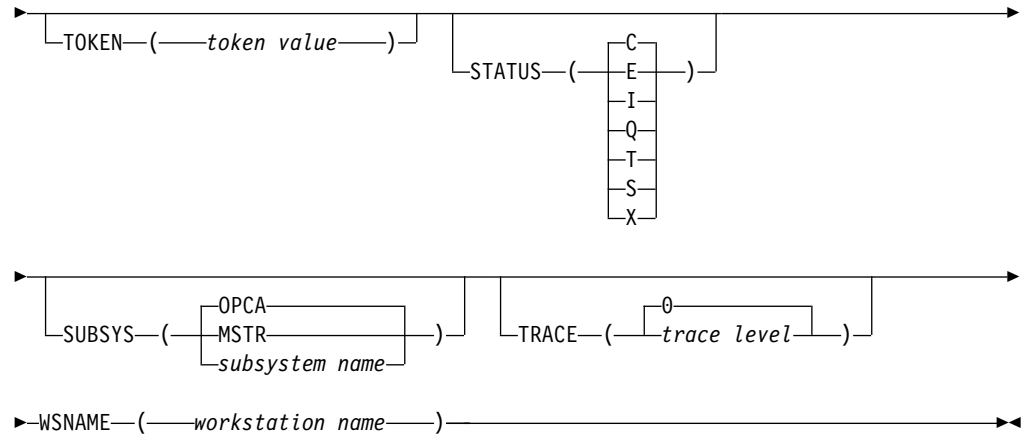

## SRSTAT

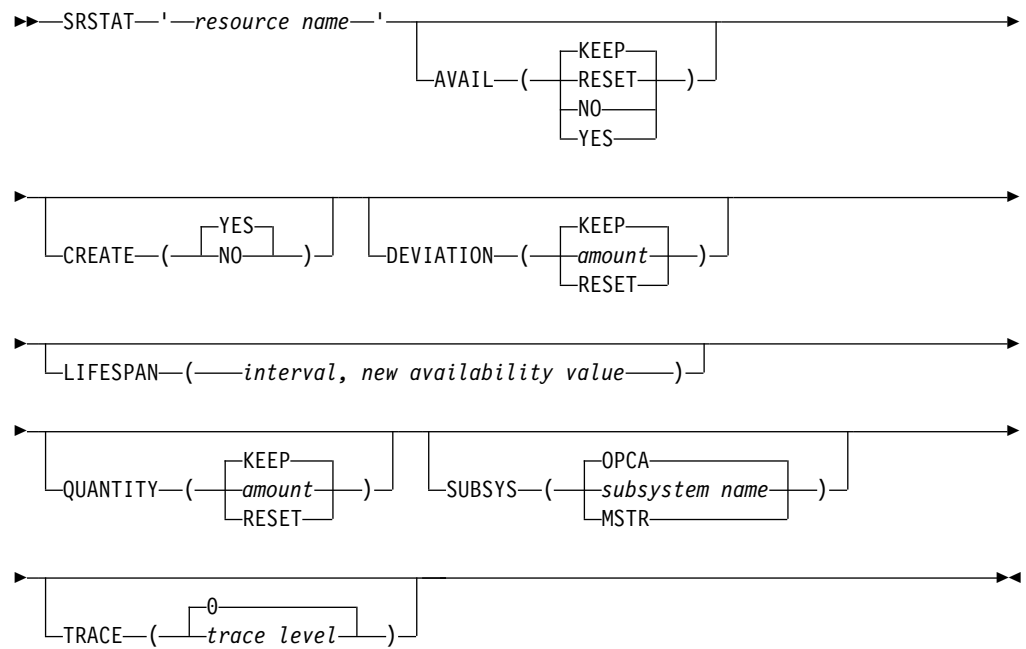

## WSSTAT

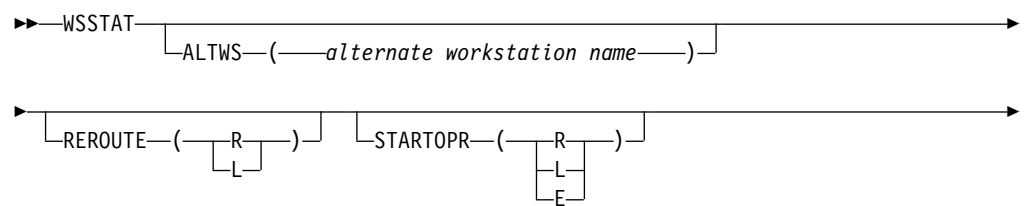

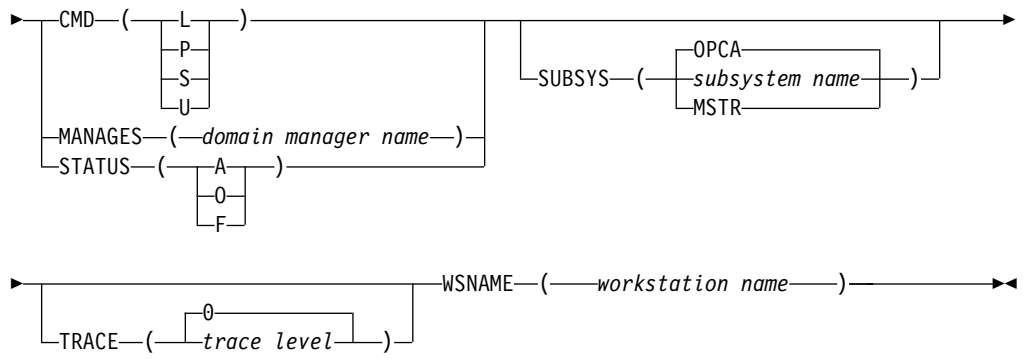

---

## Chapter 3. Commands to control the scheduler

You can start, stop, cancel, or modify the scheduler by using the following operator commands:

<b>S</b>	START
<b>P</b>	STOP
<b>C</b>	CANCEL
<b>F</b>	MODIFY

In addition, you can use the MODIFY (F) command to start and stop individual subtasks.

You can enter these commands from a multiple console support (MCS) console or from a program such as the spool display and search facility (SDSF). In both cases, the terminal or console operator must have the required authority to enter operator commands.

---

### Starting the scheduler

To start IBM® Z Workload Scheduler, enter this z/OS operator command:

```
/S procname
```

where *procname* is the IBM Z Workload Scheduler JCL procedure name.

If a started task with this name is already active, the second attempt to invoke it ends with an error message. If this happens, the started task in error cannot write an error message to the message log (DD name EQQMLOG) because the message log is already being used by the active started task. If IBM Z Workload Scheduler is to run as a batch job, do not start it with an operator command. Instead, submit a batch job with the same name as IBM Z Workload Scheduler subsystem. JES starts this job in the same manner as any ordinary job.

**Note:** Because IBM Z Workload Scheduler uses JES exits, among other things, to track the progress of z/OS jobs, it does not start before JES is active.

---

### Stopping the scheduler

To stop IBM Z Workload Scheduler, enter the following z/OS operator command:

```
/P procname
```

where *procname* is the IBM Z Workload Scheduler JCL procedure name

If you are stopping a controller, the controller creates a backup copy of the current plan data set (if required) and ends all active functions.

When IBM Z Workload Scheduler ends, it writes this message to the message log:

```
EQZ086I NO ACTIVE OPC SUBTASKS.  
OPC IS ENDING
```

---

## Canceling the scheduler

If IBM Z Workload Scheduler is still active 5 minutes after you enter the STOP operator command, you must cancel IBM Z Workload Scheduler.

You might also need to cancel IBM Z Workload Scheduler if the current plan is corrupt, because a normal shutdown causes a backup to the alternate file (refer to *Customization and Tuning* for details of current plan recovery). There are two ways to do this. The first is to enter:

```
/C procname,DUMP
```

where *procname* is the IBM Z Workload Scheduler JCL procedure name.

This causes IBM Z Workload Scheduler to end with a dump on the SYSMDUMP file (if the DD name is in the started-task JCL). The second way is to enter:

```
/C procname
```

where *procname* is the IBM Z Workload Scheduler JCL procedure name.

This causes IBM Z Workload Scheduler to end without a dump.

If the STOP command is ineffective and you have no earlier documentation of the problem, cancel IBM Z Workload Scheduler with a dump so that the error can be located.

---

## Modifying the scheduler

Use the MODIFY command to supply information to IBM Z Workload Scheduler after it has started. The syntax of the MODIFY command is:

```
/F procname,modifyoption
```

where:

*procname*

The IBM Z Workload Scheduler JCL procedure name.

*modifyoption*

Can be one of the following:

**S=taskname**

Starts the specified subtask.

**P=taskname**

Stops the specified subtask.

*taskname* can be one of the following:

**APPC** APPC subtask.

**AR** Automatic recovery subtask.

**A4** APPC tracker router subtask.

**CPH** Critical path handler subtask.

**DRT** Data router subtask.

**EMGR**

Event manager subtask.

**ERDR** All active event-reader subtasks.

**EWTR** Event writer subtask.  
**EXA** External router subtask.  
**FL** Fetch job log task.  
**GEN** General service subtask.  
**HTC** HTTP Client subtask.  
**HTS** HTTP Server subtask.  
**IP** TCP/IP router subtask.  
**JCC** Job-completion-checker subtask.  
**NMM** Normal-mode-manager subtask. The normal mode manager must be restarted as soon as possible after it has stopped. Many functions of IBM Z Workload Scheduler require an active NMM task to execute successfully.

#### **PENF53**

Deactivates the ENF mechanism implemented for the ENF 53 event. In this way, a dynamic time change for all the IBM Z Workload Scheduler subsystems cannot be performed. By default, the ENF 53 mechanism is automatically deactivated when the controller is stopped.

**PSU** Pre-submit task.

#### **RODM**

RODM subtask.

#### **SENF53**

Activates the ENF mechanism implemented for the ENF 53 event, so that a dynamic time change for all the IBM Z Workload Scheduler subsystems can be performed. By default, the ENF 53 mechanism is automatically activated at controller startup.

**SUB** Submit subtask.

**TWS** End-to-end with fault tolerance capabilities task.

#### **VTAM®**

Network communication function (NCF) subtask.

**WSA** Workstation analyzer subtask.

Only the tasks in IBM Z Workload Scheduler subtask table can be activated by a MODIFY command. The subtask table is built when IBM Z Workload Scheduler is started. This means that you can only start a task that has stopped earlier in the current session. If you attempt to start a started subtask or stop a stopped subtask, error message EQQZ049W is issued, and no action is taken.

### **BKSTATUS**

Issue this command on the primary controller or backup controller to collect detailed information about plans, JT events, and processes. By comparing the information that is returned in EQQMLOG, you can verify the alignment status between the controllers.

For example, on the primary controller, the following messages are shown in EQQMLOG:

```

EQQN133I PRIMARY CONTROLLER INFO:
EQQN133I CP INFO:
EQQN133I - CP RUN          : 00000004
EQQN133I - CP TOD         : CDDD39D2CA9AB661
EQQN133I LTP INFO:
EQQN133I - LT RUN         : 00000002
EQQN133I - LT TOD         : CDDD39D526710741
EQQN133I LATEST WRITTEN JT EVENT INFO:
EQQN133I - EVENT TYPE     : 29
EQQN133I - SEQUENCE NUMBER: 00000CD3
EQQN133I - TIME STAMP     : 141006/16522655
EQQN133I LATEST TRANSFER PLAN INFO:
EQQN133I - NCP JOB NAME   : ROZSENC
EQQN133I - NCP JOB ID     : STC00814
EQQN133I - NCP JOB STATUS : C
EQQN133I - LTP JOB NAME   : ROZSENLT
EQQN133I - LTP JOB ID     : STC00813
EQQN133I - LTP JOB STATUS : C
EQQN133I - CP1 JOB NAME   :
EQQN133I - CP1 JOB ID     :
EQQN133I - CP1 JOB STATUS :

```

On the backup controller, the following messages are shown in EQQMLOG:

```

BACKUP CONTROLLER INFO:
CP INFO:
- CP PLAN AVAILABLE       : Y
- CP PLAN DDNAME         : EQQCP1DS
- CP PLAN RUN NUMBER     : 00000004
- CP PLAN TOD KEY        : CDDD39D2CA9AB661
LTP INFO:
- LT PLAN AVAILABLE       : Y
- LT PLAN RUN NUMBER     : 00000002
- LT PLAN TOD KEY        : CDDD39D526710741
LATEST WRITTEN JT EVENT INFO:
- JT TYPE                 : 29
- JT SEQNO                : 00000C15
- JT TIMESTAMP            : 141006/16264299
SYNCHRONIZATION INFO:
- SYNC IS IN PROGRESS    : N
- SYNC TYPE               :
- NCP STATUS              : restore not needed
- CP1 STATUS              : restore not needed
- CP2 STATUS              : restore not needed
- LTP STATUS              : restore not needed
LATEST RESTORE PLAN INFO:
- NCP JOB NAME           : ROZSENC
- NCP JOB ID             : STC00805
- NCP JOB STATUS         : N
BKTAKEOVER INFO:
- POSTPONED              : N
-----

```

## **BKTAKEOVER**

Orders a backup controller to take over the functions of the primary controller. Issue this command on the backup controller.

Specify the option **BKTAKEOVER, FORCE** to force the backup controller takeover, even when the connection between the controllers is apparently up and running. Specify the option **BKTAKEOVER, NOSUB** to deactivate the job-submit option, even if **JTOPTS JOBSUBMIT(YES)** is set.

**Note:** The backup controller takeover can occur if you have set the appropriate parameters in BKPTOPTS and TRROPTS initialization statements. For details about these statements, see *Customization and Tuning*.

#### **CDP=ON**

Activates the CDP logging. This command is effective provided that OPCOPTS CDPPATH=*path\_to\_CDP\_log\_files* was already set at controller startup.

#### **CDP=OFF**

Deactivates the CDP logging.

#### **CPQSTA=ON**

Activates the STATMSG(CPLOCK) message.

#### **CPQSTA=OFF**

Deactivates the STATMSG(CPLOCK) message.

#### **DEPLOYCF**

Use this keyword to manually start the deployment process that refreshes the trackers event configuration file (member EQQEVLSST of the EQQJCLIB data set) according to the current content of the controller EQQEVLIB data set.

The process can update the event configuration file for the trackers that are currently connected. At the end of the deployment process, each connected tracker monitors for the events that match the refreshed data, based on an in-storage copy of the configuration file. If a tracker destination is referenced in the controller routing options (ROUTOPTS statement), but it is not currently connected, the tracker acquires the configuration file data when the connection is restored.

#### **DSPDEST**

Lists the HTTP destinations that are currently used by the controller. The list is stored in the message log.

#### **DSPSMOOTHSUB**

Displays all the values that are set for the smooth submission feature in the JTOPTS and BATCHOPT statements.

#### **DSPPRODD**

Lists the DD names for data sets that cannot be discarded. The list can be obtained in one of the following ways:

- In the initial parameter statements: RCLOPTS DDPROT or DDPRMEM
- With the MODIFY command /F *procname*,PROT(DD=*member*)

#### **DSPPRODS**

Lists the data sets that cannot be discarded. The list can be obtained in one of the following ways:

- In the initial parameter statements: RCLOPTS DSNPROT or DSNPRMEM
- With the MODIFY command /F *procname*,PROT(DS=*member*)

#### **DSPSTA**

Displays, in message EQQZ095, the status of statistics messaging. The message indicates whether messaging is active for EVENTS,

CPLOCKS, GENSERV, and WSATASK. It also gives the values currently set for EVELIM and STATIM. For details, refer to *Messages and Codes*.

**EVELIM=nnnn**

Sets the new value of the EVELIM keyword of the JTOPTS statement. Allowed values are 0 to 9999.

**EVESTA=ON**

Activates the STATMSG(EVENTS) message.

**EVESTA=OFF**

Deactivates the STATMSG(EVENTS) message.

**GENSTA=ON**

Activates the STATMSG(GENSERV) message.

**GENSTA=OFF**

Deactivates the STATMSG(GENSERV) message.

**JCLDBG=ON**

Activates the single JCL trace. For each job handled by WSA task information, such as the elapsed time in milliseconds needed to handle the job, retrieve the JCL, access the JS VSAM, or whatever else, will be shown.

This is a powerful trace and should be activated only for short periods of time to identify possible performance problems.

**JCLDBG=OFF**

Deactivates the single JCL trace.

**LSTNOERR**

The controller lists the NOERROR table content. An example of the command output follows:

```
EQZ024I Current NOERROR table content:
EQZ024I !-----!-----!
EQZ024I ! Statement                               ! Member  !
EQZ024I !-----!-----!
EQN067I ! ABC123.*.*.0016.GE                       ! STDCWSN !
EQN067I ! ABC123.*.*.0012.NE                       ! STDCWSN !
EQN067I ! ABC123.*.*.0016.EQ                       ! STDCWSN !
EQN067I ! ABC123.*.*.0500.TO.0610                  ! NOERR2  !
EQN067I ! ABC123.*.*.0200.TO.0210                  ! NOERR2  !
EQN067I ! ABC123.*.*.0005.LT                       ! NOERR   !
EQZ024I !-----!-----!
```

The information returned in the Member column can help you locate members to be updated.

**MAXSUB=nnnn**

Sets the new value of the MAXSUBJOBS keyword of the OPCOPTS statement. Allowed values are 0 to 9999.

**MCPDSSTART**

Use this command to create and use an MCP data space. This overrides MCPDATASPACE(NO) in the JTOPTS statement.

**MCPDSSTOP**

Use this command to stop using and delete the MCP data space. This overrides MCPDATASPACE(YES) in the JTOPTS statement.

**NEWDSLST**

Use this command on the tracker side to rebuild the triggering



selection table. The new table is read from member EQQEVLSST (or EQQDSLST, if EQQEVLSST does not exist) of the data set referenced by the EQQJCLIB DD name in the started task JCL for the tracker. The new table replaces the table in ECSA.

**Note:** If EQQJCLIB contains both EQQEVLSST and EQQDSLST member, the resulting triggering selection table is the union of EQQEVLSST and EQQDSLST. In this case, EQQEVLSST data is processed first.

## NOERROR

You can use the commands NEWNOERR and NOERRMEM() only if NOERROR entries are coded under the LIST() keyword of the NOERROR statement.

For a description of the NOERROR initialization statement, see *Customization and Tuning*.

When you enter a NEWNOERR command, the program searches the controller PARMLIB member only for NOERROR init statements. If none are found, an empty table is created, thus deleting the entries which were loaded when the CONTROLLER started. Do not use the NEWNOERR command if the NOERROR list is coded under the NOERROR() keyword of the JTOPTS initialization statement. If you enter a NOERRMEM(*membername*) command, the current table is deleted and created again. The entries that had already been specified for *membername* are replaced with the entries found in the updated member of the EQQPARM library.

When using NOERROR, consider the following:

- Use this keyword only if you are sure you can stop the controller before updating the NOERROR data.
- Initialization statements cannot exceed 32 KB or 455 72-character lines. The available space for NOERROR entries in the initialization statement is more limited compared with using this keyword in the JTOPTS statement.
- Do not mix the three options for defining NOERROR entries:
  - JTOPTS NOERROR ()
  - NOERROR LIST () in the main parmlib member
  - NOERROR LIST () in separate parmlib members identified by the INCLUDE() initialization statement

The options for dynamically updating controller data are mutually exclusive and using them incorrectly might cause the deletion of the active table.

- If you must dynamically update the NOERROR data without stopping the controller, and the NOERROR entries are defined in a separate parmlib member, place all NOERROR entries in a single parmlib member. In this way, you can use only one member name in the NOERRMEM command.

## NEWNOERR

Orders a controller to rebuild the NOERROR table, in the case NOERROR statements have been modified in the parameter library member that contains the JTOPTS statement.

## NOERRMEM(*member*)

Orders a controller to rebuild the NOERROR table, in the case

NOERROR statements have been modified in a parameter library member that was specified in an INCLUDE statement.

#### **NOERRMEM(M1)**

Order a controller to delete all NOERROR codes defined by member M1, once you have previously changed M1 to contain only comments. The modified member can contain a different number of NOERROR codes than the original member.

**Note:** The scheduler opens the EQQPARM library when IBM Z Workload Scheduler is started and parameter library members (residing in library extents), that have been created, cannot be accessed, after have been opened. To avoid this problem, the data sets that define the EQQPARM library should be allocated without any secondary extents.

#### **PROT ([DD=*mem1*], [DS=*mem2*])**

Replaces the currently used list contents of the members (*mem1* and *mem2*) inside the PDS parameter library, if DD or DSN is protected. At least one of the two keywords DD or DS must be specified. The list of protected DD and DSN is dropped when *mem1* or *mem2* is blank. Also, the keywords DD and DS remove the list of protected DD names and DS names.

For example, if DDPROT is used in the parameter library at startup of the controller, the command drops this list and replaces it with the contents of *mem1*.

#### **QUELEN=*nmmn***

Sets the new value of the QUEUELEN keyword of the JTOPTS statement. Allowed values are 0 to 9999, but a minimum value of 5 is forced.

#### **RFRDEST**

If you modify, add, or delete an HTTP or HTTPS destination in ROUTOPTS while IBM Z Workload Scheduler is running, makes your changes immediately effective. This command does *not* update any changes you make to the PROXY parameter in ROUTOPTS.

RFRDEST manages up to a total of 100 new destinations, regardless if you add them at once or at different times. For detailed information about the destinations set by ROUTOPTS, see *Customization and Tuning*.

#### **RFRUSER**

If you modify the USRREC statement while IBM Z Workload Scheduler is running, makes your changes immediately effective. For detailed information, see *Scheduling End-to-end with z-centric Capabilities*.

#### **RFRUX14T**

If you modify the criteria table pointed by the UX14IN DD name in the controller started task while the controller is running, makes your changes effective for the operations that become ready after modifying the table.

To make the changes effective also for the operations that were ready before you modified the table, you must replan the current plan.

For detailed information about the time-dependent-operation exit, see *Customization and Tuning*.

| **SETSMOOTHCRITNET=ON**

| Sets the SMOOTHCRITNET parameter in JTOPTS to YES, to  
| prioritize the submission of operations belonging to the whole  
| critical network.

| **SETSMOOTHCRITNET=OFF**

| Sets the SMOOTHCRITNET parameter in JTOPTS to NO.

| **SETSMOOTHRATE=nnnn**

| Changes the value for the SMOOTHSUBRATE parameter in the  
| JTOPTS statement. Valid values are in the range from 0 to 99999. 0  
| means that the SMOOTHSUBRATE parameter is not set.

| **SETSMOOTHSUB=ON**

| Activates the smooth submission feature. To make it effective, run  
| either a daily planning EXTEND or REPLAN.

| **SETSMOOTHSUB=OFF**

| Deactivates the smooth submission feature. To make it effective,  
| run either a daily planning EXTEND or REPLAN.

| **SKIPINC(member name)**

| Replaces the currently used list of INCLUDEs that are to be left at  
| the beginning of a JCL by the JCL tailoring process of Restart and  
| Cleanup. *member name* can be:

- The name of a member inside the PDS parameter library
- Blank or absent

When a member name is specified, the current SKIPINCLUDE list is deleted and a new SKIPINCLUDE list is built by applying the syntax described for the RCLSKIP statement to the specified member. When no member name is specified, the current SKIPINCLUDE list is removed.

For details about RCLOPTS(SKIPINCLUDE) and the RCLSKIP statement, see *Customization and Tuning*.

| **STATIM=nn**

| Sets the new value of the STATIM keyword of the JTOPTS  
| statement. Allowed values are 0 to 99.

| **STATUS**

| Returns a message on the system log with the status of IBM Z  
| Workload Scheduler subsystem. The status can be one of the  
| following:

| **FULLY\_OPERATIONAL**

| Everything is active and is working properly.

| **PARTIALLY\_OPERATIONAL**

| The scheduler subsystem has limited functionality. For  
| example, if a controller ER is stopped, the controller can  
| still schedule jobs but cannot receive their statuses.

| **NOT\_OPERATIONAL**

| The major subsystem functionality is not available. For  
| example, a controller is not able to execute a plan or to  
| submit a job.

**STATUS, DD=*ddname***

Checks for the status of IBM Z Workload Scheduler data set associated with the specified *ddname*. *ddname* can be a specific DD name, such as EQQWSDS, EQQCP1DS, or EQQLTDS, or it can assume the value ALL, CP, DB, LTP, or JTL. It returns the return code of the last I/O operation performed on that *ddname*. The status of the data set can be one of the following:

NORMAL  
WARNING  
SEVERE  
CRITICAL  
UNKNOWN

**STATUS, {OP\_COMP | OP\_ERR}, "*destination name*"**

Returns the number of completed operations (OP\_COMP) or the number of ended-in-error operations (OP\_ERR) for the specified tracker (*destination name*).

**Note:**

1. If more than one workstation is defined for tracker *tracker name*, the number of completed or in-error operations is the sum of the operations on all the workstations defined on that tracker.
2. *destination name* is the destination name of a tracker, as specified in the ROUTOPTS keyword in the initialization statements.

**STATUS, SUBTASK**

Lists all subtasks with their statuses. The status can be ACTIVE or INACTIVE.

**SWITCHMLOG**

If the MLOG switching feature is in use, forces the switch to the alternate data set (EQQMLOG or EQQMLOG2), regardless of the number of currently logged records, and starts counting from 0 again.

**TAKEOVER**

Orders a standby controller to take over the functions of the controller. This command is valid only when both systems are part of the same XCF group, and no controller is active. You can use this command only for IBM Z Workload Scheduler address spaces where OPCHOST(STANDBY) is specified in the OPCOPTS statement.

**Note:** Takeover can occur automatically if you have specified the TAKEOVER keyword in the XCFOPTS statement of a standby system. For details about the XCFOPTS statement, see *Customization and Tuning*.

**TRYNOERR(*member name*)**

Start a trial processing of the NOERROR statements contained in *member name*. The controller issues all the normal processing messages in EQQMLOG. At the end of the trial processing, the controller issues message EQQN099I, leaving unchanged the NOERROR table.

*member name* is a member of the EQQPARM library.

**VSTRC=START**

Starts a trace on the message log of all VSAM I/O requests. In a busy scheduler system, you will need a large message-log data set, and the trace will affect the performance of IBM Z Workload Scheduler system.

**VSTRC=STOP**

Stops a VSAM I/O request trace on the message log.

**WSASTA=ON**

Activates the STATMSG(WSATASK) message.

**WSASTA=OFF**

Deactivates the STATMSG(WSATASK) message.

After the STOP command is entered, the MODIFY command no longer functions, and issues the following message on SYSLOG:

```
IEE324I MODIFY REJECTED - TASK BUSY
```

---

## Modifying the data store

Use the MODIFY command to supply information to IBM Z Workload Scheduler data store after it has started. The syntax of the MODIFY command is:

```
/F procname,modifyoption
```

where:

*procname*

The IBM Z Workload Scheduler JCL procedure name.

*modifyoption*

Can be one of the following:

**S=taskname**

Start the specified data store subtask.

**P=taskname**

Stop the specified data store subtask.

*taskname* can be one of the following:

**ARRD**

Reader task.

**ARCU** Cleanup task.

**ARCM**

Communication.

**ARDYWR**

Display number of active writers.

**ARDYTW**

Display WINTERVAL value.

**ARDYNY**

Display MAXSTOL value.

**ARDYNS**

Display MAXSYSL value.

**ARDYTU**

Display CINTERVAL value.

**ARDYNS**

Display MAXSYSL value.

**ARDYPM**

Display all initialization parameters values.

**ARSTKW O=[owner],K=[keyword]**

Display the statistical data for a specific owner or single keyword. The following describes the keyword and owner combinations:

*Table 2. Keyword and owner combinations*

Owner	Keyword	Meaning
JESQUEUE	COUNTJOB	Number of jobs still in the JES Queue control block
JESQUEUE	JOBINSQU	Number of jobs inserted in the JES Queue control block
JESQUEUE	DSIDINSQ	Number of DS IDs (sysout) inserted in the JES Queue control block
JESQUEUE	JOBQUEUE	Number of jobs re-queued: deleted from the JES Queue control block after the store
JESQUEUE	JOBDISCA	Number of jobs discarded: deleted from the JES Queue control block because of an error during the store in the database
DATAFILEnnnn	CNTDPAGE	Number of data pages for the data file specified
READER	JOBQSDDB	Number of jobs requested directly to the database
READER	JOBQJES	Number of jobs requested to JES Queue because they are not stored in the database yet
COMMUNICATION	INPUTMSG	Number of input messages received
COMMUNICATION	OUTPTMSG	Number of output messages sent

**ARSTGN**

Display all the statistics for the data store.

**ARMDWR**

Modify number of active writers.

**ARMDTW=n**

Modify WINTERVAL value (seconds).

**ARMDNY=n**

Modify MAXSTOL value (number of lines).

**ARMDNS=n**

Modify MAXSYSL value (number of lines).

**ARMDTU=n**

Modify CINTERVAL value (seconds).

**ARMDNS=n**

Modify MAXSYSL value (number of lines).

**ARDGCM=on/off**

Activate or deactivate Communication task traces.

**ARDGWR=on/off**

Activate or deactivate Writer task traces.

**ARDGRD=on/off**

Activate or deactivate Reader task traces.

**ARDGJQ=on/off**

Activate or deactivate JES Queue task traces.

**ARDGDB=on/off**

Activate or deactivate Database task traces.





# Chapter 4. Automatic recovery

## RECOVER statement

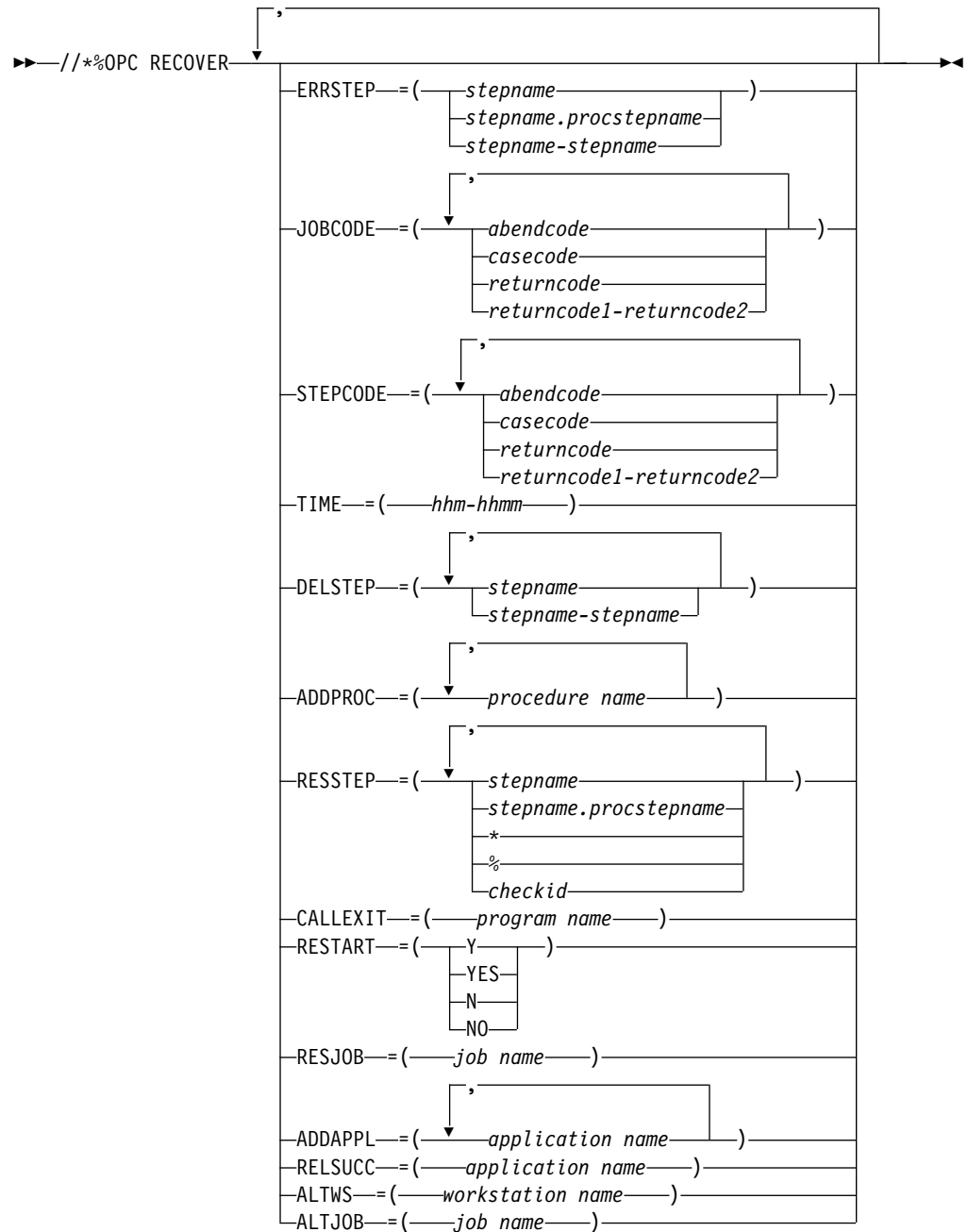

You cannot have JCL variables on the RECOVER statement.



---

## Chapter 5. JCL directives

---

### NOP directive

▶▶—//\*%OPC NOP—▶▶

---

### SCAN directive

▶▶—//\*%OPC SCAN—▶▶

---

### SEARCH directive

▶▶—//\*%OPC SEARCH—NAME=—(—▶▶

table name

APPL

NOAPPL

GLOBAL

NOGLOBAL

▶▶

---

### TABLE directive

▶▶—//\*%OPC TABLE—NAME=—(—table name—)▶▶

---

### SETFORM directive

▶▶—//\*%OPC SETFORM—dynamic-variable-name=—(—format—)▶▶

---

### Usage notes

- Choose the variable from Table 6 on page 31.
- Compose the format from one or more of these keywords and any other characters except &, %, ?, =, (, and ):

CC Century (2 digits)  
YY Year (2 digits)  
MM Month  
DDD Day in year (Julian)  
DD Day in month  
HH Hour (time variables only)  
MM Minutes (time variables only)

## SETVAR directive

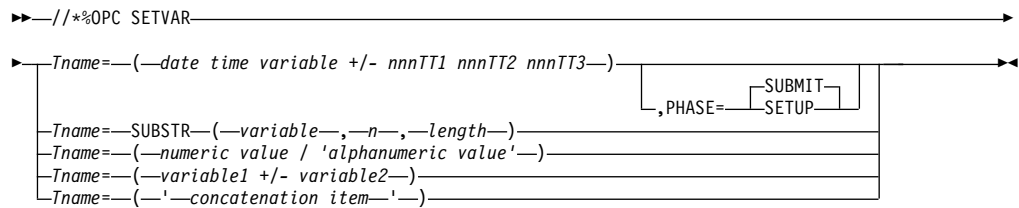

### Usage notes

- Use parentheses around the expression for the temporary variable Tname.
- Begin the variable Tname with the letter T.
- TT1 is the first possible type and can be one of the following values:
  - WD** Work days
  - CD** Calendar days
  - WK** Weeks
  - MO** Months
  - YR** Years
  - HH** Hours
  - MM** Minutes
  - SS** Seconds
- TT2 and TT3 are additional types allowed only for time-related variables. They can be one of the following values:
  - HH** Hours
  - MM** Minutes
  - SS** Seconds

## BEGIN and END directives

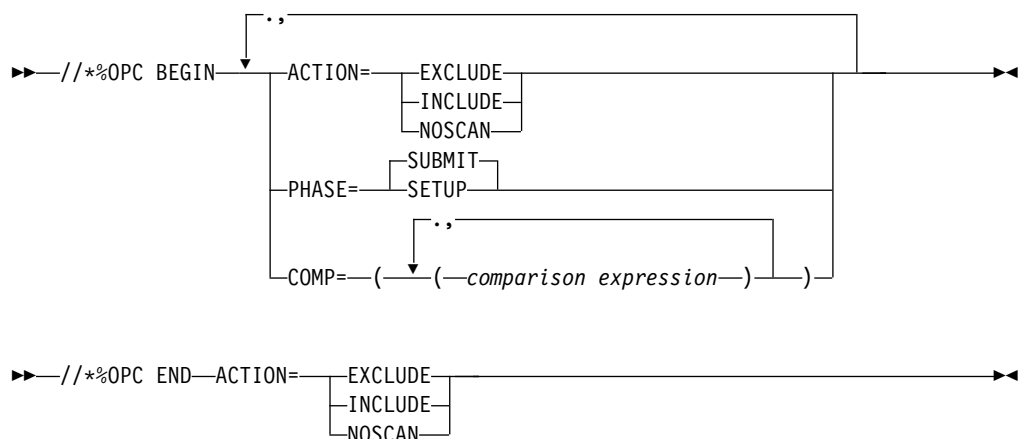

## FETCH directive

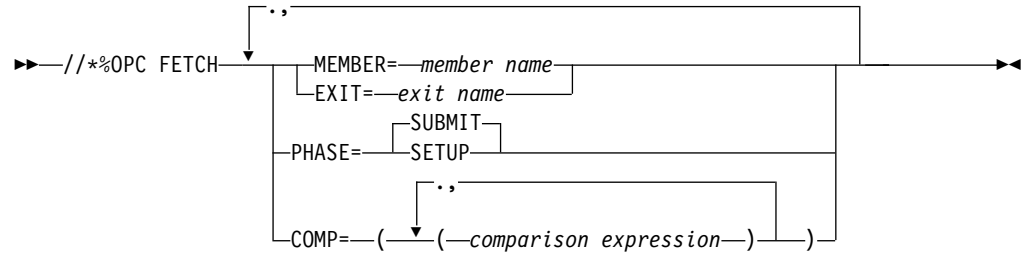

## COMP keyword on BEGIN and FETCH directives

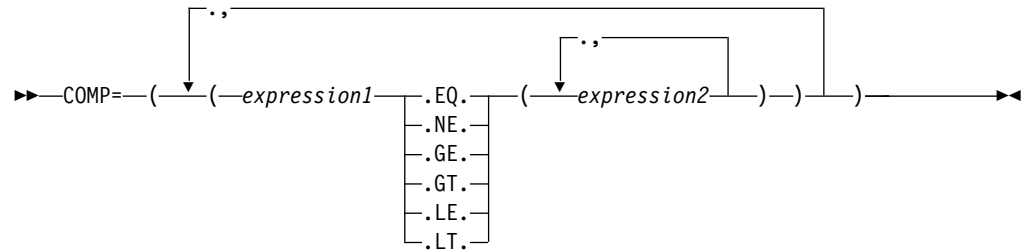

### Usage notes

Only & (ampersand) variables are valid in the COMP expressions, and embedded blanks are not allowed.



## Chapter 6. Supplied JCL variables

Note: IA = input arrival

### Occurrence-related JCL variables

Table 3. Occurrence-related supplied JCL variables

Variable name	Length (bytes)	Description								
OADID	16	Application ID								
OADOWNER	16	Occurrence owner								
OAUGROUP	8	Authority group								
OALID	16	Calendar name								
ODAY	1	Occurrence IA day of the week (1-7); 1 represents Monday								
ODD	2	Occurrence IA day of month, in DD format								
ODDD	3	Occurrence IA day of the year, in DDD format								
ODMY1	6	Occurrence IA date in DDMMYY format								
ODMY2	8	Occurrence IA date in DD/MM/YY format								
OFREEDAY	1	Denotes whether the occurrence IA date is a free day (F), or a workday (W)								
OHH	2	Occurrence IA hour in HH format								
OHHMM	4	Occurrence IA hour and minute in HHMM format								
OMM	2	Occurrence IA month in MM format								
OMMY	4	Occurrence IA month and year in MMY format								
OWW	2	Occurrence IA week of the year in WW format								
OWWD	3	Occurrence IA week, and day within week, in WWD format, where WW is the week number within the year, and D is the day within the week								
OWWLAST	1	A value, Y (yes) or N (no), that indicates whether the occurrence IA date is in the last week of the month								
OWWMONTH	1	A value between 1 and 6 that indicates the occurrence IA week-in-month, where each new week begins on a Monday. For example, consider these occurrence IA dates for the month of January in 1996:  <table border="0"> <tr> <td><b>Date</b></td> <td><b>Value</b></td> </tr> <tr> <td><b>Monday 1st</b></td> <td>1</td> </tr> <tr> <td><b>Monday 8th</b></td> <td>2</td> </tr> <tr> <td><b>Wednesday 31st</b></td> <td>5</td> </tr> </table>	<b>Date</b>	<b>Value</b>	<b>Monday 1st</b>	1	<b>Monday 8th</b>	2	<b>Wednesday 31st</b>	5
<b>Date</b>	<b>Value</b>									
<b>Monday 1st</b>	1									
<b>Monday 8th</b>	2									
<b>Wednesday 31st</b>	5									
OYMD	8	Occurrence IA date in YYYYMMDD format								
OYM	6	Occurrence IA month within year in YYYYMM format								
OYMD1	6	Occurrence IA date in YYMMDD format								
OYMD2	8	Occurrence IA date in YY/MM/DD format								

Table 3. Occurrence-related supplied JCL variables (continued)

Variable name	Length (bytes)	Description
OYMD3	10	Occurrence IA date in YYYY/MM/DD format
OYY	2	Occurrence IA year in YY format
OYYDDD	5	Occurrence IA date as a Julian date in YYDDD format
OYYMM	4	Occurrence IA month within year in YYMM format
OYYYY	4	Occurrence IA year in YYYY format, for example, 1996

## Operation-related JCL variables

Table 4. Operation-related JCL variables

Variable name	Length (bytes)	Description
OJOBNAME	8	Operation job name
OLDAY	1	Operation latest start day (1–7); 1 represents Monday, 7 represents Sunday
OLDD	2	Operation latest start day (day in the month)
OLHH	2	Operation latest start hour
OLHHMM	4	Operation latest start in hours and minutes
OLMD	4	Operation latest start time (month and day), in MMDD format
OLMM	2	Operation latest start time in month, in MM format
OLWK	2	Operation latest start week (week in the year), WW format
OLYMD	6	Operation latest start date in YYMMDD format
OLYDDD	5	Operation latest start in Julian date format (YYDDD)
OOPNO	3	Operation number within the occurrence, right-justified and padded with zeros
OWSID	4	Workstation ID for current operation
OXJOBNAM	54	Extended job name set in the current plan at operation level. If you entered any blank character in the Extended Job Name field, the OXJOBNAM value is truncated at the first blank.

## Date-related JCL variables

Table 5. Date-related JCL variables

Variable name	Length (bytes)	Description
CDAY	1	Current day of the week; 1 represents Monday, 7 represents Sunday
CDD	2	Current day of month in DD format
CDDD	3	Day number in the current year
CDDMMYY	6	Current date in DDMMYY format
CHH	2	Current time in HH format
CHHMM	4	Current hour and minute in HHMM format



Table 5. Date-related JCL variables (continued)

Variable name	Length (bytes)	Description
CHMMSSX	8	Current hour, minute, second, and hundredths of seconds in HHMMSSXX format
CMM	2	Current month in MM format
CMMYY	4	Current month within year in MMY format
CWW	2	Week number in the current year
CWWD	3	Current day within week in WWD format, where WW is the week number within the year and D is the day within the week
CYMD	8	Current date in YYYYMMDD format
CYY	2	Current year in YY format
CYDDD	5	Current Julian date in YDDD format
CYMM	4	Current month within year in YMM format
CYMMDD	6	Current date in YMMDD format
CYYY	4	Current year in YYYY format, for example, 1990
CYYYMM	6	Current month within year in YYYYMM format

## Dynamic-format supplied variables

Table 6. Dynamic-format date-related supplied variables

Variable name	Description
CDATE	Current date
CTIME	Current time
OCDATE	Occurrence IA date
OCFRSTC	First calendar day in month of the occurrence IA date
OCFRSTW	First work day in the month of the occurrence IA date
OCFRSTWY	First work day in the year of the occurrence IA date
OCLASTC	Last calendar day in the month of the occurrence IA date
OCLASTW	Last work day in the month of the occurrence IA date
OCLASTWY	Last work day in the year of the occurrence IA date
OCTIME	Occurrence IA time (hours and minutes)
OPIADATE	Operation IA date (if blank, this takes the value of the occurrence IA date)
OPIATIME	Operation IA time (if blank, this takes the value of the occurrence IA time)
OPLSDATE	Operation latest start date
OPLSTIME	Operation latest start time



---

## Chapter 7. Codes

The following is a list of the occurrence status codes:

- C Complete
- D Deleted
- E An operation in the occurrence has ended-in-error
- P A pending predecessor exists for the occurrence
- S Started
- U Undecided (the status is not known)
- W No operations in the occurrence have started.

---

### Operation status codes

When the scheduler displays the status of an operation, it uses the format *xy*, where *x* is the status code and *y*, if present, is the extended status code. The following is a list of the operation status codes:

- A Arriving. The operation is ready for processing; no predecessors were defined
- C Complete
- D Deleted
- E The operation has ended-in-error
- I The operation is interrupted
- R Ready for processing; all predecessors are complete
- S Started
- U Undecided. The operation status is not known.
- W The operation is waiting for a predecessor to complete
- X The operation is suppressed by condition.
- \* Ready. At least one predecessor is defined on a non-reporting workstation; all predecessors are complete

---

### Extended status codes

Together with the normal status codes, the scheduler maintains extended status codes that provide additional information about the status of operations. The extended status code is not always present.

The following is a list of the extended status codes:

- 3 The scheduler is sending an HTTP or HTTPS request to bind the shadow job to a real instance in the remote plan.
- 4 The scheduler is waiting to receive the result of the HTTP or HTTPS request that was sent to bind the shadow job to a real instance in the remote plan.
- 5 The bind between the shadow job and a real instance in the remote plan was established.

- A The job is waiting for a manual cleanup action to be initiated or discarded by a panel user (the cleanup type is manual).
- B The job is waiting for a cleanup action to be started (the cleanup type is automatic or immediate).
- C A restart and cleanup process is in progress (data set cleanup or step restart, or both). The job is waiting for the process to be completed.
- D Close down is in progress.
- E An error occurred during job submission or release.
- G The operation is running on a WAIT workstation (it is a dummy operation waiting for the delay period to elapse).
- H A panel user has used the HOLD command on the operation.
- L The operation is a late time-dependent operation with the suppress-if-late attribute.
- M The status of the operation has been manually set.
- N A panel user has used the NOP command on the operation.
- O Workstation is offline.
- Q For z/OS jobs the job has been added to the JES job queue. For fault-tolerant workstations, it is waiting for submission.
- R The operation has ended in error but was automatically reset (the completion code is defined in the installation options to be automatically reset).
- S The job or started task is executing.
- T Waiting until a particular time.
- U Submit is in progress.
- V The limit value of this fault-tolerant workstation was reached.
- W Waiting for scheduling environment.
- X Waiting for resource.
- Y The job ended with an error code matching a NOERROR entry.

For operations on computer workstations, a blank extended status has a particular meaning for the following statuses:

**Arrived (A) or Ready (\* or R)**

The scheduler is in the process of submitting this job. The scheduler is waiting for the availability of a parallel server or a critical resource, or the operation is not to be submitted automatically.

**Started (S)**

The job has been successfully submitted but has not yet been reported as added to the JES job queue.

---

## Error codes

The scheduler assigns error codes to certain operations and to job and started task steps. These codes are used by the automatic job recovery function to decide a recovery action.

- CAN** The job or started task was canceled by the operator or by a TSO user before execution. This code is also possible if the job-termination event (type 3P) is missing.
- CCUN** The completion code is unknown. The job or started task has ended, but no completion code is available. This code is also possible if the job-end event (type 3J) is missing.  
Check the job log and SYSLOG.
- CLNA** A failure occurred when IBM Z Workload Scheduler attempted to complete the JCL tailoring during the restart and cleanup process.
- CLNC** A failure occurred when IBM Z Workload Scheduler attempted to run the data set cleanup during the restart and cleanup process.
- CLNO** A failure occurred when IBM Z Workload Scheduler attempted to retrieve the historical job log data during the restart and cleanup process. *nnnn* Step return code. **S xxx** System abend code. **U xxx** User abend code in hexadecimal notation. For example, user abend 2750 is represented in IBM Z Workload Scheduler as UABE. *xxxx* User-defined error code.
- CLNP** A failure occurred in the EQQCLEAN step, during the run of a restarted job.
- JCCE** An error during JCC (job completion checker) processing prevented the JCC from determining an error code for the operation.
- FBND** The request to bind the shadow job with a real instance of the remote plan failed.
- JCL** A JCL error was recognized after the job or started task began to execute, or a JCL error was recognized after syntax checking in the internal reader.
- JCLI** A JCL error occurred immediately; that is, the error was detected before the job or started task began. This code is also possible when both the job-start event (type 2) and the job-end event (type 3J) are missing. On z-centric agent workstations, this code is returned when a parsing error occurs in the JOBREC statement.
- LOOP** The workstation analyzer task has tried to start the same operation repeatedly and message EQQW534E has been stored in the controller MLOG to signal a loop. To stop the loop, the operation was set to error with error code LOOP.
- MCP** The operation was manually set to error in the MCP panel. **OFxx** The system that the operation is defined on has gone offline. The WSOFFLINE parameter on the JTOPTS initialization statement specifies that started operations should be marked as ended-in-error. *xx* is the status and extended status of the failing operation. Operations that were running (status SS) have a step-code error status of OFFL.
- nnnn* Step return code.
- OAUT** While running the System Automation command specified with the operation, the System Automation exit EQQUXSAZ issued a return code

different from 0. The operation status is set to E. Check for System Automation messages in the log specified in the AUTOMATIONMSG parameter of the OPCOPTS statement.

**OFxx** The system that the operation is defined on has gone offline. The WSOFFLINE parameter on the JTOPTS initialization statement specifies that started operations should be marked as ended-in-error. *xx* is the status and extended status of the failing operation. Operations that were running (status SS) have a step-code error status of OFFL.

#### **OJCV**

An error occurred during JCL-variable substitution when the job or started task was submitted, or IBM Z Workload Scheduler detected an error in the RECOVER statement during automatic recovery. Browse the JCL for the operation or the EQQMLOG data set to find more information about the failure.

This error code can also be issued when an error occurred during variable substitution in a System Automation command text. The operation status could be set to E, based on the SAVARFAIL parameter set in the OPCOPTS initialization statement. To identify the variables not resolved and the type of error occurred, check for the messages related to occurrence variable substitution in EQQMLOG.

#### **OSEQ**

A job or started task began to execute before all its predecessors have completed. This can occur only if the job was not submitted by IBM Z Workload Scheduler and if either HOLDJOB(NO) or HOLDJOB(USER) is specified for IBM Z Workload Scheduler event writer options. For fault-tolerant workstations, the OSEQ code can indicate that a dependency on another operation or a special resource was added after the job started, but before the event reached the controller. See *Customization and Tuning*.

#### **OSUB**

A failure occurred when IBM Z Workload Scheduler attempted to submit a job or start a started task. In the case of a started task, it could be that the started task is a subsystem that is not started by JES, or IBM Z Workload Scheduler subsystem EQQSTC ddname is not allocated to a JES-defined procedure library. The operation should be marked as ended-in-error.

For jobs running on z-centric agent workstations and z/OS shadow jobs, OSUB indicates that the job submission failed.

#### **OSUF**

A failure occurred when IBM Z Workload Scheduler attempted to retrieve the JCL for a job or started task. This code is set if the SUBFAILACTION keyword of the JTOPTS initialization statement specifies that the operation should be marked as ended-in-error. This code is also caused if you have JOBCHECK(SAME) and the job name in the application description does not match the one on the job card. Another reason for this code is a job is missing JCL that was packed by ISPF in EQQJBLIB.

In end-to-end scheduling with fault tolerance capabilities, this code indicates that an error occurred while the scheduler was queuing the submission event for the job. For jobs with centralized scripts it might also show that IBM Z Workload Scheduler could not download the script to the distributed agent.

**OSUP**

A time operation is late, and the SUPPRESSACTION parameter of the JTOPTS initialization statement specified that the operation should be marked as ended-in-error.

**OSxx** The system on which the operation is defined has failed. The WSFAILURE parameter on the JTOPTS initialization statement specifies that started operations should be marked as ended-in-error. *xx* is the status and extended status of the failing operation. Operations that were running (status SS) have a step-code error of OSYS.

**PCAN**

A print operation was canceled by the operator.

*nnnn* Step return code.

**SERC** An operation submitted in a Restart and Clean up path (through a dialog but also automatically, for example, when clean up was set to AUTOMATIC) was not submitted because the required scheduling environment was not available..

**SEUN** An operation required a scheduling environment that is unknown to WLM; for this reason it was not submitted.

**SHPF** The request to bind the shadow job is rejected.

**Sxxx** System abend code.

**Uxxx** User abend code in hexadecimal notation. For example user abend 2750 is represented in IBM Z Workload Scheduler as UABE.

*xxxx* User-defined error code.

## Job log retrieval status codes

When the job log retrieval function is used, the scheduler maintains status information to report on the retrieval of the log. The following is a list of the status codes:

**C** Completed. The controller has received the log.

**E** Error. There was an error retrieving the log.

**I** Initiated. The controller has sent a retrieval request to the tracker, but the tracker has not yet processed the request.

**S** Started. The controller has sent a retrieval request to the tracker, and the tracker has started to retrieve the log.

**blank** The controller has not sent any retrieval request to the tracker.

## Operation reason codes

If you include the RSNC field in the ready list, you get these operation reason codes. The codes are listed in hierarchical order. For example, if job submission failed, and job submission is deactivated, code D is obtained, not code F.

**1** Not enough free WS resource 1

**2** Not enough free WS resource 2

**A** Automatic reset error condition

**C** Workstation is closed

<b>D</b>	Job submission deactivated
<b>F</b>	Job submission failed
<b>H</b>	Closedown in progress
<b>J</b>	No automatic job submission
<b>L</b>	Job is late
<b>O</b>	Work station is offline
<b>P</b>	All parallel servers in use
<b>S</b>	Special resource is unavailable
<b>T</b>	Start time not reached
<b>U</b>	Work station is unlinked



---

## Chapter 8. Free-day rule

### About this task

The possible values of the free-day rule are:

- E Count only work days when using the rule or offset. That is, free days are excluded. This option ensures that the scheduled day will always be a work day. This is the default for offset-based run cycles.
- 1 Count work days and free days when using the rule or offset. If this gives a free day, schedule the application on the closest work day *before* the free day.
- 2 Count work days and free days when using the rule or offset. If this gives a free day, schedule the application on the closest work day *after* the free day.
- 3 Count work days and free days when using the rule or offset. If this gives a free day, schedule the application *on* the free day. This is the default for rule-based run cycles.
- 4 Count work days and free days when using the rule or offset. If this gives a free day, *do not* schedule the application at all.

The free-day rule provides the flexibility to schedule your applications precisely when they are required. Sometimes you will find that you must work out on paper which free-day rule you should select. When you do this, consider what would happen if a normal work day is declared a holiday and, therefore, is defined in the calendar as a free day.

When an application is normally due to run but the calendar definition identifies the day as free, the free-day rule in the run cycle for that application determines the effect.



---

## Chapter 9. Defining day to day workload

---

### Job related

#### NOERROR syntax for JCL return code management

▶▶ NOERROR LIST ( ( error code entry ) )

For the parameter descriptions, refer to *Customization and Tuning*.

#### USRREC syntax for end-to-end scheduling

▶▶ USRREC USRCPU ( ( cpu name ) ) USRNAM ( ( logon ID ) )  
▶▶ USRPSW ( ( password ) )

For the parameter descriptions, refer to *Scheduling End-to-end with Fault Tolerance Capabilities*.

---

### Modeling related for end-to-end scheduling

#### CPUREC

▶▶ CPUREC CPUNAME ( ( cpu name ) ) CPUOS ( ( AIX  
HPUX  
POSIX  
UNIX  
WNT  
OTHER  
IBM i ) )

▶▶ CPUNODE ( ( node name ) )  
    CPUTCPIP ( ( port number ) )

▶▶ CPUDOMAIN ( ( domain name ) ) CPUHOST ( ( cpu name ) )

▶▶ CPUACCESS ( ( access method ) ) CPUTYPE ( ( FTA  
SAGENT  
XAGENT ) )

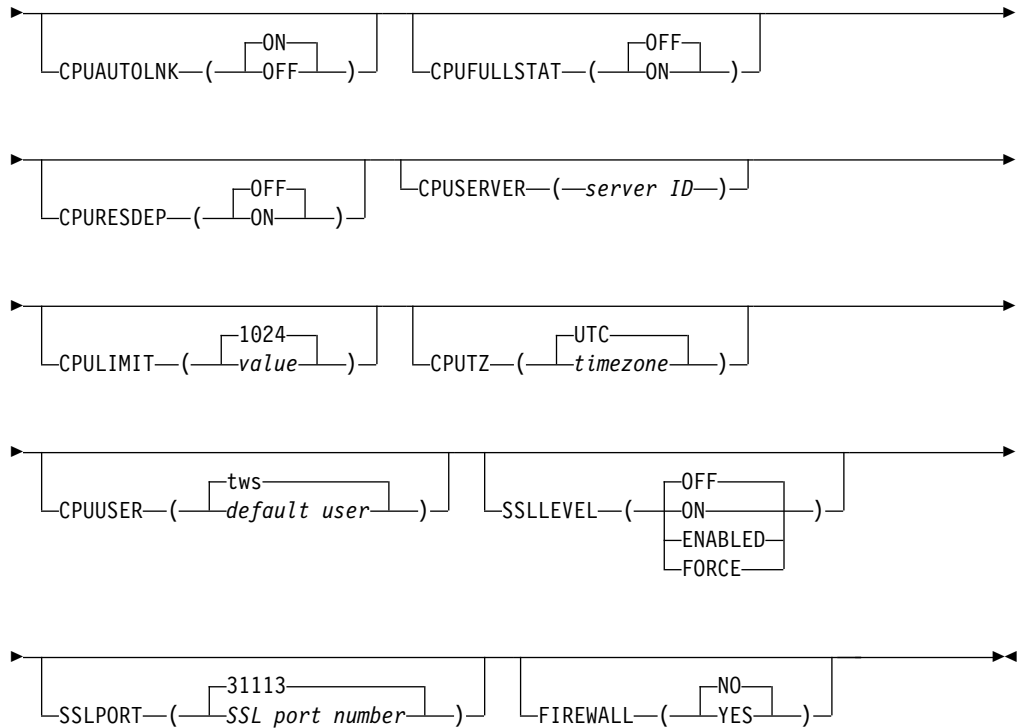

For the parameter descriptions, refer to *Scheduling End-to-end with Fault Tolerance Capabilities*.

## DOMREC

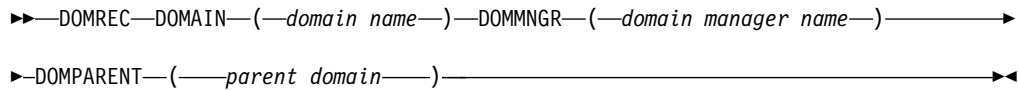

For the parameter description, refer to *Scheduling End-to-end with Fault Tolerance Capabilities*.

---

## Notices

This information was developed for products and services offered in the US. This material might be available from IBM in other languages. However, you may be required to own a copy of the product or product version in that language in order to access it.

IBM may not offer the products, services, or features discussed in this document in other countries. Consult your local IBM representative for information on the products and services currently available in your area. Any reference to an IBM product, program, or service is not intended to state or imply that only that IBM product, program, or service may be used. Any functionally equivalent product, program, or service that does not infringe any IBM intellectual property right may be used instead. However, it is the user's responsibility to evaluate and verify the operation of any non-IBM product, program, or service.

IBM may have patents or pending patent applications covering subject matter described in this document. The furnishing of this document does not grant you any license to these patents. You can send license inquiries, in writing, to:

*IBM Director of Licensing  
IBM Corporation  
North Castle Drive, MD-NC119  
Armonk, NY 10504-1785  
US*

For license inquiries regarding double-byte character set (DBCS) information, contact the IBM Intellectual Property Department in your country or send inquiries, in writing, to:

*Intellectual Property Licensing  
Legal and Intellectual Property Law  
IBM Japan Ltd.  
19-21, Nihonbashi-Hakozakicho, Chuo-ku  
Tokyo 103-8510, Japan*

INTERNATIONAL BUSINESS MACHINES CORPORATION PROVIDES THIS PUBLICATION "AS IS" WITHOUT WARRANTY OF ANY KIND, EITHER EXPRESS OR IMPLIED, INCLUDING, BUT NOT LIMITED TO, THE IMPLIED WARRANTIES OF NON-INFRINGEMENT, MERCHANTABILITY OR FITNESS FOR A PARTICULAR PURPOSE. Some jurisdictions do not allow disclaimer of express or implied warranties in certain transactions, therefore, this statement may not apply to you.

This information could include technical inaccuracies or typographical errors. Changes are periodically made to the information herein; these changes will be incorporated in new editions of the publication. IBM may make improvements and/or changes in the product(s) and/or the program(s) described in this publication at any time without notice.

Any references in this information to non-IBM websites are provided for convenience only and do not in any manner serve as an endorsement of those

websites. The materials at those websites are not part of the materials for this IBM product and use of those websites is at your own risk.

IBM may use or distribute any of the information you provide in any way it believes appropriate without incurring any obligation to you.

Licensees of this program who wish to have information about it for the purpose of enabling: (i) the exchange of information between independently created programs and other programs (including this one) and (ii) the mutual use of the information which has been exchanged, should contact:

*IBM Director of Licensing  
IBM Corporation  
North Castle Drive, MD-NC119  
Armonk, NY 10504-1785  
US*

Such information may be available, subject to appropriate terms and conditions, including in some cases, payment of a fee.

The licensed program described in this document and all licensed material available for it are provided by IBM under terms of the IBM Customer Agreement, IBM International Program License Agreement or any equivalent agreement between us.

The performance data discussed herein is presented as derived under specific operating conditions. Actual results may vary.

Information concerning non-IBM products was obtained from the suppliers of those products, their published announcements or other publicly available sources. IBM has not tested those products and cannot confirm the accuracy of performance, compatibility or any other claims related to non-IBM products. Questions on the capabilities of non-IBM products should be addressed to the suppliers of those products.

This information is for planning purposes only. The information herein is subject to change before the products described become available.

This information contains examples of data and reports used in daily business operations. To illustrate them as completely as possible, the examples include the names of individuals, companies, brands, and products. All of these names are fictitious and any similarity to actual people or business enterprises is entirely coincidental.

#### COPYRIGHT LICENSE:

This information contains sample application programs in source language, which illustrate programming techniques on various operating platforms. You may copy, modify, and distribute these sample programs in any form without payment to IBM, for the purposes of developing, using, marketing or distributing application programs conforming to the application programming interface for the operating platform for which the sample programs are written. These examples have not been thoroughly tested under all conditions. IBM, therefore, cannot guarantee or imply reliability, serviceability, or function of these programs. The sample programs are provided "AS IS", without warranty of any kind. IBM shall not be liable for any damages arising out of your use of the sample programs.

© (your company name) (year).  
Portions of this code are derived from IBM Corp. Sample Programs.  
© Copyright IBM Corp. \_enter the year or years\_.

---

## Trademarks

IBM, the IBM logo, and [ibm.com](http://ibm.com) are trademarks or registered trademarks of International Business Machines Corp., registered in many jurisdictions worldwide. Other product and service names might be trademarks of IBM or other companies. A current list of IBM trademarks is available on the web at "Copyright and trademark information" at [www.ibm.com/legal/copytrade.shtml](http://www.ibm.com/legal/copytrade.shtml).

Adobe, the Adobe logo, PostScript, and the PostScript logo are either registered trademarks or trademarks of Adobe Systems Incorporated in the United States, and/or other countries.

IT Infrastructure Library is a Registered Trade Mark of AXELOS Limited.

Linear Tape-Open, LTO, the LTO Logo, Ultrium, and the Ultrium logo are trademarks of HP, IBM Corp. and Quantum in the U.S. and other countries.

Intel, Intel logo, Intel Inside, Intel Inside logo, Intel Centrino, Intel Centrino logo, Celeron, Intel Xeon, Intel SpeedStep, Itanium, and Pentium are trademarks or registered trademarks of Intel Corporation or its subsidiaries in the United States and other countries.

Linux is a registered trademark of Linus Torvalds in the United States, other countries, or both.

Microsoft, Windows, Windows NT, and the Windows logo are trademarks of Microsoft Corporation in the United States, other countries, or both.



Java™ and all Java-based trademarks and logos are trademarks or registered trademarks of Oracle and/or its affiliates.

Cell Broadband Engine is a trademark of Sony Computer Entertainment, Inc. in the United States, other countries, or both and is used under license therefrom.

ITIL is a Registered Trade Mark of AXELOS Limited.

UNIX is a registered trademark of The Open Group in the United States and other countries.

---

## Terms and conditions for product documentation

Permissions for the use of these publications are granted subject to the following terms and conditions.

## **Applicability**

These terms and conditions are in addition to any terms of use for the IBM website.

## **Personal use**

You may reproduce these publications for your personal, noncommercial use provided that all proprietary notices are preserved. You may not distribute, display or make derivative work of these publications, or any portion thereof, without the express consent of IBM.

## **Commercial use**

You may reproduce, distribute and display these publications solely within your enterprise provided that all proprietary notices are preserved. You may not make derivative works of these publications, or reproduce, distribute or display these publications or any portion thereof outside your enterprise, without the express consent of IBM.

## **Rights**

Except as expressly granted in this permission, no other permissions, licenses or rights are granted, either express or implied, to the publications or any information, data, software or other intellectual property contained therein.

IBM reserves the right to withdraw the permissions granted herein whenever, in its discretion, the use of the publications is detrimental to its interest or, as determined by IBM, the above instructions are not being properly followed.

You may not download, export or re-export this information except in full compliance with all applicable laws and regulations, including all United States export laws and regulations.

IBM MAKES NO GUARANTEE ABOUT THE CONTENT OF THESE PUBLICATIONS. THE PUBLICATIONS ARE PROVIDED "AS-IS" AND WITHOUT WARRANTY OF ANY KIND, EITHER EXPRESSED OR IMPLIED, INCLUDING BUT NOT LIMITED TO IMPLIED WARRANTIES OF MERCHANTABILITY, NON-INFRINGEMENT, AND FITNESS FOR A PARTICULAR PURPOSE.



---

# Index

## Special characters

\* (asterisk) operation status code 33

## A

A extended status code 33

A operation status code 33

### APARs

PK24559 38

PK71539 11

PK73549 18

PK87319 38

PM01090 15

PM04927 35

PQ6977 26

PQ87904 35

asterisk (\*) operation status code 33

## B

B extended status code 33

blank, extended status code 33, 34

## C

C extended status code 33

C occurrence status code 33

C operation status code 33

CAN error code 35

CANCEL command, OS/390 10

CCUN error code 35

CDATE, JCL variable 31

CDAY, JCL variable 30

CDD, JCL variable 30

CDDD, JCL variable 30

CDDMMYY, JCL variable 30

CHH, JCL variable 30

CHHMM, JCL variable 30

CLNA error code 35

CLNC error code 35

CLNO error code 35

CMM, JCL variable 31

CMMYY, JCL variable 31

### codes

error 34

extended status codes 33

job log retrieval 37

status codes for occurrences 33

status codes for operations 33

### commands

OS/390

CANCEL 10

MODIFY 10

START 9

STOP 9

CTIME, JCL variable 31

CWW, JCL variable 31

CWWD, JCL variable 31

CYMD, JCL variable 31

CYY, JCL variable 31

CYYDDD, JCL variable 31

CYYMM, JCL variable 31

CYYMDD, JCL variable 31

CYYYY, JCL variable 31

CYYYYMM, JCL variable 31

## D

D extended status code 33

D occurrence status code 33

D operation status code 33

## E

E extended status code 33

E occurrence status code 33

E operation status code 33

error codes 34

job log retrieval 37

extended status codes 33

## F

FBND error code 35

## G

G extended status code 33

## H

H extended status code 33

## I

I operation status code 33

## J

JCCE error code 35

JCL

error code 35

JCLI error code 35

job log retrieval

status codes 37

JTOPTS initialization statement

SUBFAILACTION keyword 36

WSFAILURE keyword 37

WSOFFLINE keyword 36

## L

L extended status code 33

LOOP error code 35

## M

M extended status code 33

MCP error code 35

MODIFY command, OS/390 10

## N

N extended status code 33

nnnn error code 35, 37

normal mode manager 11

## O

O extended status code 33

OADID, JCL variable 29

OADOWNER, JCL variable 29

OAUGROUP, JCL variable 29

OAUT error code 35

OALID, JCL variable 29

occurrences

status codes 33

OCDATE, JCL variable 31

OCFRSTC, JCL variable 31

OCFRSTW, JCL variable 31

OCFRSTWY, JCL variable 31

OCLASTC, JCL variable 31

OCLASTW, JCL variable 31

OCLASTWY, JCL variable 31

OCTIME, JCL variable 31

ODAY, JCL variable 29

ODD, JCL variable 29

ODDD, JCL variable 29

ODMY1, JCL variable 29

ODMY2, JCL variable 29

OFREEDAY, JCL variable 29

OFxx error code 36

OHH, JCL variable 29

OHHMM, JCL variable 29

OJCV error code 36

OJOBNAME, JCL variable 30

OLDAY, JCL variable 30

OLDD, JCL variable 30

OLHH, JCL variable 30

OLHHMM, JCL variable 30

OLMD, JCL variable 30

OLMM, JCL variable 30

OLWK, JCL variable 30

OLYMD, JCL variable 30

OLYYDDD, JCL variable 30

OMM, JCL variable 29

OMMY, JCL variable 29

OOPNO, JCL variable 30

Operation reason codes 37

operations

extended status codes 33

status codes 33

operator commands, z/OS 9

OPIADATE, JCL variable 31

OPIATIME, JCL variable 31

OPLSDATE, JCL variable 31

OPLSTIME, JCL variable 31  
 OS/390  
   CANCEL command 10  
   MODIFY command 10  
   START command 9  
   STOP command 9  
 OSEQ error code 36  
 OSUB error code 36  
 OSUF error code 36  
 OSUP error code 37  
 OSxx error code 37  
 OWSID, JCL variable 30  
 OWWW, JCL variable 29  
 OWWD, JCL variable 29  
 OWWLAST, JCL variable 29  
 OWWWMONTH, JCL variable 29  
 OXJOBNAM, JCL variable 30  
 OYM, JCL variable 29  
 OYMD, JCL variable 29  
 OYMD1, JCL variable 29  
 OYMD2, JCL variable 29  
 OYMD3, JCL variable 30  
 OYY, JCL variable 30  
 OYYDDD, JCL variable 30  
 OYYMM, JCL variable 30  
 OYYYY, JCL variable 30

## P

P occurrence status code 33  
 PCAN error code 37

## Q

Q extended status code 33

## R

R extended status code 33  
 R operation status code 33  
 Reason codes 37  
 restart and cleanup  
   error codes 35, 37

## S

S extended status code 33  
 S occurrence status code 33  
 S operation status code 33  
 SERC error code 37  
 SHPF error code 37  
 START command, OS/390 9  
 status codes  
   extended 33  
   job log retrieval 37  
   occurrence 33  
   operation 33  
 STOP command, OS/390 9  
 SUBFAILACTION keyword of  
   JTOPTS 36  
 subsystem  
   cancelling with OS/390 10  
   modifying with OS/390 10  
   starting with OS/390 9  
   stopping with OS/390 9

Sxxx error code 37

## T

T extended status code 33

## U

U extended status code 33  
 U occurrence status code 33  
 U operation status code 33  
 Uxxx error code 37

## V

V extended status code 33

## W

W extended status code 33  
 W occurrence status code 33  
 W operation status code 33  
 WSFAILURE keyword of JTOPTS 37  
 WSOFFLINE keyword of JTOPTS 36

## X

X extended status code 33  
 xxxx error code 37

## Y

Y extended status code 33

## Z

z/OS  
   operator commands 9





Product Number: 5698-T08

Printed in USA