

z/OS



TSO/E Administration

Version 2 Release 1

Note

Before using this information and the product it supports, read the information in "Notices" on page 165.

This edition applies to Version 2 Release 1 of z/OS (5650-ZOS) and to all subsequent releases and modifications until otherwise indicated in new editions.

© **Copyright IBM Corporation 1988, 2013.**

US Government Users Restricted Rights – Use, duplication or disclosure restricted by GSA ADP Schedule Contract with IBM Corp.

Contents

Figures	vii
--------------------------	------------

Tables	ix
-------------------------	-----------

About this document	xi
Who should use this document	xi
How this document is organized	xi
Where to find more information	xiii

How to send your comments to IBM	xv
If you have a technical problem	xv

z/OS Version 2 Release 1 summary of changes	xvii
--	-------------

Part 1. Introduction 1

Chapter 1. Administering TSO/E and the Information Center Facility. 3

Administering TSO/E	3
Administering the Information Center Facility	3
Messages	5
Using the ISPF/PDF Editor	6
Displaying PF Key Definitions	6
Using Commands	7
Administering APPC/MVS Information	7
Exiting from the Information Center Facility	8

Part 2. Administering TSO/E. 9

Chapter 2. Defining Users to TSO/E 11

Overview of Defining Users to TSO/E	11
Selecting a User ID	11
Ways to Define Users	11
ENROLL Option.	12
RACF Commands	12
Converting to the RACF Data Base	13
Defining Aliases in the Master Catalog	13
TSO/E ACCOUNT Command	13

Chapter 3. Using the ACCOUNT Command 15

Overview of Using the ACCOUNT Command.	15
Structure of UADS Entries	15
Using ACCOUNT Subcommands	17
Listing Information about UADS Entries.	18
Examples	18
Adding a User Definition.	19
Examples	20
Adding New Information to an Existing User Definition	21
Examples	22

Changing Information in a User Definition	23
Examples	24
Deleting Information from a User Definition	25
Examples	25

Part 3. Administering the Information Center Facility 27

Chapter 4. Maintaining the News Service 29

Overview of Maintaining the News Service.	29
Maintaining News Items	29
Printing a News Item	30
Viewing a News Item	31
Viewing a New Item of News	31
Adding a News Item	31
Modifying a News Item	32
Deleting a News Item	33

Chapter 5. Maintaining the Names Directory 35

Overview of Maintaining the Names Directory	35
Maintaining Names in the Master Directory	36
Viewing a Name.	37
Modifying a Name	37
Deleting a Name	37
Adding a Name	38
Maintaining Groups in the Master Names Directory	38
Viewing a Group	39
Modifying a Group.	39
Deleting a Group	40
Adding a Group.	40
Processing User Requests to Update the Master Directory	41
To process a request	41
Maintaining the TRANSMIT/RECEIVE Names File	42
To update NAMES.TEXT	42

Chapter 6. Maintaining Courses 43

Overview of Maintaining Courses	43
Maintaining Course Names, Conditions, and Abstracts	44
Course Name.	44
Course Condition	44
Course Abstract	45
Displaying the Course List	45
Viewing a Course Abstract	45
Printing a Course Abstract	45
Adding a Course	46
Modifying a Course	47
Deleting a Course	48
Processing Registration Requests	48
Displaying Student Registration Requests	48

Processing Requests for Registration in Classroom Courses	49
Processing Requests for Registration in IIPS Courses.	49
Updating Course Registration Lists	51
Displaying the Course Registration List	52
Adding a Student to the Registration List	52
Deleting a Student from the Registration List	52
Invoking IIPS as an IIPS Administrator	53
To sign on	53
Modifying Administration Defaults	53
IIPS Student and Author IDs	53
High-Level Qualifier for IIPS Data Sets	53
Course Conditions Suppressed from the User List	53
Modifying the Defaults	53

Chapter 7. Enrolling Users Through the Information Center Facility 55

Overview of Enrolling Users Through the Information Center Facility	55
Procedure for Enrolling People	56
To enroll a person through the Information Center Facility	56
Setting ISPF Defaults	60
To change an ISPF default profile	60
Resynchronizing ISPF Defaults	61
To reset ISPF default profile tables.	61
ENROLL Worksheet	61
Canceling User Enrollment	62

Chapter 8. Maintaining User Type Definitions 63

Overview of Maintaining User Type Definitions	63
Accessing Currently Defined User Types	64
TSO/E User ID Information	65
TSO/E Authorization Information	67
RACF Security Information	68
Optional RACF Information	70
VSAM DEFINE ALIAS Parameters	70
Adding a User Type	71
To add a user type	71
Modifying a User Type	72
To modify the parameters	72
Deleting a User Type	73
To delete a user type	73

Chapter 9. Setting System Defaults: ISPF Profile. 75

Overview of Setting System defaults: ISPF Profile	75
Changing the System Default ISPF Profile	75

Chapter 10. Setting System Defaults: Printer Support 77

Overview of Setting System Defaults: Printer Support	77
Creating and Maintaining Default Print Definitions	77
Accessing a Print Definition	79
To access a print definition	79
Adding a Print Definition	79

Specifying a Printer Identification	80
Specifying a Print Function	82
Specifying Parameters	84
Specifying General Parameters	84
Specifying General PRINTDS Parameters	88
Specifying Fonts	95
Testing Print Definitions	96
Deleting a Print Definition	98
To delete a print definition	98
Print Definition Worksheet	98

Chapter 11. Setting System Defaults: Application Manager 101

Overview of Setting System Defaults: Application Manager	101
Managing Multiple Level Applications	102
Considerations for Multilevel Applications	102
Authority Requirements	104
Summary of Valid Operations for each Level of Administration	104
Invoking Application Manager Dialogs	105
Invoking Application Manager Dialogs at the System Level	105
Invoking Application Manager Dialogs at the Group Level.	105
Invoking Application Manager Dialogs at the Private Level	107
Displaying the List of Applications	107
To view a specific application	108
Generating a Hierarchy Display	109
To end displaying a hierarchy	111
Adding an Application	111
Adding an Application with an Installation File	111
Adding an Application without an Installation File	115
Creating an Installation File from an Existing Application	133
To create an installation file using an existing application	133
Upgrading an Installation File	135
Syntax of Upgrade Files	136
Encountering an Error in the Upgrade File	139
Copying an Application	142
To copy	142
To test.	142
To save the new application	142
To discard the new application	142
Deleting an Application	142
To delete	143
To confirm the deletion	143
To cancel the deletion	143
Testing an Application (For Panels and Functions)	143
Modifying an Application	143
To test.	143
To save the modified application	143
To discard the modifications	143
Replacing an Existing Application	144
Seeing Where an Existing Application is Used	144
To see where an application is used	144
To end seeing where an application is used	145
Sample Information Sheets	145

Information Sheet for Environments	145
Information Sheet for Functions	146
Information Sheet for Panels	147

Installation Written JCL Override Sample for Mass Export	157
---	-----

Chapter 12. Mass Installation File

Processing	149
Overview of Mass Installation File Processing . . .	149
Functions of the Mass Installation File Process . .	149
Mass Upgrade and Install	150
Mass Export	150
Messages Pertaining to Processing	151
Using the Mass Installation File Process	151
Considerations for mass installation file processing	151
Creating a Mass Export List of Applications File	152
Invoking the Mass Installation File Process . .	153
Installation Example for Mass Installation File	
Processing	155
ICQMIFP Sample	155

Part 4. Appendixes 159

Appendix. Accessibility 161

Accessibility features	161
Using assistive technologies	161
Keyboard navigation of the user interface	161
Dotted decimal syntax diagrams	161

Notices 165

Policy for unsupported hardware.	166
Minimum supported hardware	167
Trademarks	167

Index 169

Figures

1. Main Menu Panel for Administrator Tasks	4	45. Printer – Test the Print Definition	97
2. The Simplest Structure for a UADS Entry	16	46. Printer – Print Function Test Results	97
3. A More Complex Structure for a UADS Entry	16	47. Printer – Delete a Print Definition	98
4. A Subcommand for Modifying Part of a UADS Entry.	17	48. Default Operations Valid for Each Level of Administration	105
5. UADS Entry Before Additions	22	49. Programmer Services Panel	106
6. UADS Entry Before Deletions	25	50. Group Identification Panel	106
7. Printer Specification Panel	30	51. Programmer Services Panel	107
8. Printer Specification Panel	46	52. Application Manager – List of Applications	108
9. Enroll – User Identification	56	53. Example of Hierarchy Display	110
10. Enroll – List of Users	57	54. Example of an Installation File for a Function	112
11. Enroll – Add or Modify a User	57	55. Application Manager – Add an Application	114
12. Enroll – Add or Modify a User	58	56. Application Manager – Installation File	114
13. Enroll – Information Center Identification	59	57. Application Manager – Define a Function	115
14. Information Center Facility – Define User Types	64	58. Application Manager – List of Applications	116
15. User Types – List of User Types.	65	59. Application Manager – Add an Application	116
16. User Types – Select User Information	65	60. Application Manager – Define an Environment	117
17. User Types – View TSO/E User ID Information	66	61. Define an Environment – General Information	117
18. User Types – View Authorization Information	67	62. Variable Definitions	118
19. User Types – View RACF Security Information	68	63. Application Libraries	119
20. User Types – View Optional RACF Information	70	64. Environment Installation File that Includes Library Entries	121
21. User Types – View User Catalog Alias	71	65. Application Commands	121
22. User Types – Specify TSO/E User ID Information	71	66. Application Manager – List of Applications	122
23. User Types – Select Option to Modify.	72	67. Application Manager – Add an Application	122
24. User Types – Specify RACF Security Information	73	68. Application Manager – Define a Function	123
25. User Types – Delete a User Type	74	69. Define a Function – General Information	123
26. Information Center Facility – System Defaults	76	70. Variable Definitions	124
27. Information Center Facility – List of Printers for Administrators	78	71. Application Libraries	125
28. Information Center Facility – List of Printers for Users	78	72. Function Installation File that Includes Library Entries	127
29. Information Center Facility – System Defaults	79	73. Application Commands	128
30. Information Center Facility – List of Printers for Administrators	79	74. Help Text for a Function	128
31. Printer – Print Definition	80	75. Application Manager – List of Applications	129
32. Printer – Printer Identification	81	76. Application Manager – Add an Application	130
33. Printer – Print Function	83	77. Application Manager – Define a Panel	130
34. Printer – General Parameters.	84	78. Define a Panel – General Information	131
35. Printer – General Parameters.	86	79. Define a Panel – Options.	132
36. Printer – General Parameters.	87	80. Help Text for a Panel	132
37. Printer – Parameters	88	81. Application Manager – List of Applications	134
38. Printer – General PRINTDS Parameters	89	82. Application Manager – Export an Application	134
39. Printer – PRINTDS – Output Format	90	83. Example of Header Portion of Upgrade Files	136
40. Printer – PRINTDS – Content Description	92	84. Operational Entries in an Upgrade File	137
41. Printer – PRINTDS – Content Description	92	85. Application Manager – List of Applications	140
42. Printer – PRINTDS – 3800 Parameters.	93	86. Application Manager - Upgrade Installation File Panel	140
43. Printer – Parameters	95	87. Application Manager – Where Used List	144
44. Printer – Print Fonts	95	88. Example of Mass Export List of Applications File	153
		89. Sample JCL Override for Mass Export	158

Tables

1. Suggestions for Defining Users to TSO/E	11	2. Valid Course Conditions and Their Meanings	44
--	----	---	----

About this document

This document supports z/OS® (5650-ZOS).

This document is intended for anyone maintaining TSO/E user definitions or Information Center Facility services at an installation. That person might be a TSO/E administrator, an Information Center Facility administrator, a system programmer, or a person involved with security.

If you are a TSO/E administrator, this document provides information to help you define users to TSO/E and maintain those definitions.

If you are an Information Center Facility administrator, this document provides information to help you do the following tasks:

- Maintain the news service, the names directory, and education services
- Enroll users to TSO/E and RACF® through the enroll service
- Assign users to user types and maintain the user type definitions
- Maintain the model ISPF profile and printer support definitions
- Maintain Information Center Facility applications.

An administrator is not necessarily either a TSO/E administrator or an Information Center Facility administrator. A TSO/E administrator might also use the Information Center Facility enroll service to define users to TSO/E. Or, an administrator might maintain only a portion of the Information Center Facility, for example, courses, while another administrator maintains news. Or, in small installations, one person might be responsible for maintaining both TSO/E and the Information Center Facility.

This document also provides a brief description of the APPC/MVS administration dialog in Chapter 1, “Administering TSO/E and the Information Center Facility,” on page 3. For detailed information about using the APPC/MVS administration dialog, refer to *z/OS MVS Planning: APPC/MVS Management*.

Who should use this document

This document is written for people who define users to TSO/E and maintain the Information Center Facility. It assumes the reader knows how to:

- Enter TSO/E commands
- Use Information Center Facility panels.

z/OS TSO/E Primer provides that information.

How this document is organized

This document is organized into three parts. The purpose of each part and the chapters within the part are:

- Part 1, “Introduction,” on page 1, contains a chapter that describes the major tasks of administering the TSO/E system and the TSO/E Information Center Facility. The chapter included in Part 1, “Introduction,” on page 1 is:
 - Chapter 1, “Administering TSO/E and the Information Center Facility,” on page 3, presents an overview of tasks required to maintain user services.

- Part 2, “Administering TSO/E,” on page 9, contains chapters that describe the ways to define users to TSO/E and how to maintain those definitions. The chapters included in Part 2, “Administering TSO/E,” on page 9 are:
 - Chapter 2, “Defining Users to TSO/E,” on page 11, describes the ways to define users to TSO/E.
 - Chapter 3, “Using the ACCOUNT Command,” on page 15, describes how to use the ACCOUNT command to list, add, change, and delete user definitions in TSO/E.
- Part 3, “Administering the Information Center Facility,” on page 27, contains chapters that describe the maintenance of services within the Information Center Facility. The chapters included in Part 3, “Administering the Information Center Facility,” on page 27 are:
 - Chapter 4, “Maintaining the News Service,” on page 29, describes how to view, add, modify, delete, and print online news using the Information Center Facility news service.
 - Chapter 5, “Maintaining the Names Directory,” on page 35, describes how to use the Information Center Facility names service to view, add, modify, and delete names directory entries, and to process user requests for master directory changes.
 - Chapter 6, “Maintaining Courses,” on page 43, describes how to use the Information Center Facility to provide online course information about classroom courses and provide access to computer courses, such as courses created by the Interactive Instructional Authoring System (IIAS) and presented using the Interactive Instructional Presentation System (IIPS).
 - Chapter 7, “Enrolling Users Through the Information Center Facility,” on page 55, describes how to define users to TSO/E, RACF, and the VSAM master catalog using the Information Center Facility enroll service.
 - Chapter 8, “Maintaining User Type Definitions,” on page 63, describes how to view, add, modify, and delete user type definitions. Administrators assign user types to people when enrolling them through the Information Center Facility.
 - Chapter 9, “Setting System Defaults: ISPF Profile,” on page 75, describes how to change the model ISPF profile through the Information Center Facility.
 - Chapter 10, “Setting System Defaults: Printer Support,” on page 77, describes how to create and manage print definitions for your installation's printers through the Information Center Facility.
 - Chapter 11, “Setting System Defaults: Application Manager,” on page 101, describes how to use Application Manager to add, change, and delete services in the Information Center Facility. You can also view, replace, and upgrade applications, generate a hierarchy display of applications, and create installation files from existing applications.
 - Chapter 12, “Mass Installation File Processing,” on page 149, describes how to use the mass installation file process to process multiple installation files, including the upgrade of these files, and to create multiple installation files from a list of applications to be exported.

The design of this document allows you to add chapters for functions unique to your installation and set aside chapters for functions not used by your installation. It is recommended that you save unused chapters in case your installation restores functions that were removed.

Where to find more information

Please see *z/OS Information Roadmap* for an overview of the documentation associated with z/OS, including the documentation available for z/OS TSO/E.

How to send your comments to IBM

We appreciate your input on this publication. Feel free to comment on the clarity, accuracy, and completeness of the information or provide any other feedback that you have.

Use one of the following methods to send your comments:

1. Send an email to mhvrcfs@us.ibm.com.
2. Send an email from the "Contact us" web page for z/OS (<http://www.ibm.com/systems/z/os/zos/webqs.html>).
3. Mail the comments to the following address:
IBM Corporation
Attention: MHVRCFS Reader Comments
Department H6MA, Building 707
2455 South Road
Poughkeepsie, NY 12601-5400
US
4. Fax the comments to us, as follows:
From the United States and Canada: 1+845+432-9405
From all other countries: Your international access code +1+845+432-9405

Include the following information:

- Your name and address.
- Your email address.
- Your telephone or fax number.
- The publication title and order number:
z/OS V2R1.0 TSO/E Administration
SA32-0977-00
- The topic and page number that is related to your comment.
- The text of your comment.

When you send comments to IBM, you grant IBM a nonexclusive right to use or distribute the comments in any way appropriate without incurring any obligation to you.

IBM or any other organizations use the personal information that you supply to contact you only about the issues that you submit.

If you have a technical problem

Do not use the feedback methods that are listed for sending comments. Instead, take one of the following actions:

- Contact your IBM service representative.
- Call IBM technical support.
- Visit the IBM Support Portal at z/OS support page (<http://www.ibm.com/systems/z/support/>).

z/OS Version 2 Release 1 summary of changes

See the following publications for all enhancements to z/OS Version 2 Release 1 (V2R1):

- *z/OS Migration*
- *z/OS Planning for Installation*
- *z/OS Summary of Message and Interface Changes*
- *z/OS Introduction and Release Guide*

Part 1. Introduction

The major tasks of a TSO/E administrator involve administering the TSO/E element of z/OS and the TSO/E Information Center Facility. The chapter provides an overview of these tasks and refers you to other chapters for more information.

Chapter 1, “Administering TSO/E and the Information Center Facility,” on page 3, defines the tasks and responsibilities of a TSO/E administrator which include defining, maintaining and deleting user definitions, and maintaining the services in the Information Center Facility.

Chapter 1. Administering TSO/E and the Information Center Facility

Administering TSO/E

If you are responsible for maintaining TSO/E user definitions, tasks you might perform include:

- **Defining users to TSO/E** – You can define users by one of the following:
 - ENROLL option of the Information Center Facility
 - RACF commands
 - TSO/E ACCOUNT command
 - Installation-written procedure
- **Maintaining user definitions** – Using the ENROLL option, RACF commands, and the ACCOUNT command, you can:
 - Add new information to a user definition
 - Change information for a user definition
 - Delete information from a user definition
- **Deleting user definitions** – Using RACF commands or the ACCOUNT command, you can remove users from TSO/E.

For information about these tasks, see Chapter 2, “Defining Users to TSO/E,” on page 11.

Administering the Information Center Facility

The Information Center Facility provides panels for six major administrative tasks.

NEWS

Maintaining the news service. As an administrator, you are responsible for adding, modifying, and deleting online news items for Information Center Facility users.

NAMES

Maintaining the master names directory. The names directory contains entries for everyone enrolled in the Information Center Facility and possibly for other people as well. You are responsible for keeping the master directory up-to-date.

ENROLL

Enrolling people through the Information Center Facility. The enrollment service is a simplified way of adding users to TSO/E and identifying them to the Information Center Facility names directory and, if installed, to RACF. You can also use the enrollment service to create a user catalog alias for the person's TSO/E user ID.

USERTYPE

Maintaining User Type definitions. When enrolling a person through the Information Center Facility, an administrator assigns that person a user type. The user type identifies a class of users, such as administrator or user. Associated with each user type are the parameters the system uses when issuing the TSO/E ACCOUNT ADD, RACF ADDUSER, and VSAM DEFINE ALIAS commands during enrollment processing. You can use Information Center Facility panels to add, modify, delete, or view User Type definitions.

Administering the Information Center Facility

SYSDEF

Setting the system defaults. The Information Center Facility has default definitions for the user ISPF profile, for printer support, and for applications in the Information Center Facility.

User ISPF profile – During enrollment, the system copies the default user profile to create a new ISPF profile for the user being enrolled.

Printer support – The Printer Support definition describes the printers available to your facility and their print characteristics.

Applications – The Application Manager allows you to add, modify, or delete products and services in the Information Center Facility.

COURSES

Maintaining educational services. This task involves maintaining online course information for computer and classroom courses and providing access to courses your installation offers using the Interactive Instructional Presentation System (IIPS) and the Interactive Instructional Authoring System (IIAS).

The Information Center Facility is divided into panels for *user* tasks and panels for *administrator* tasks. Each set of tasks starts on a main menu panel that shows a list of options with descriptions and characters for selecting the options. If your installation has not customized the Information Center Facility, your main menu panel for administrator tasks might look something like this:

```
TSO/E Information Center Facility Administration
Option ===>

Select one of the following options. To scroll, press UP or DOWN.

 0 DESCRIBE - Read a short description of the options on this panel
 1 NEWS     - Maintain System News
 2 NAMES    - Maintain the name/phone directory
 3 ENROLL   - Enroll users in the Information Center Facility
 4 USERTYPE - Set defaults for user types
 5 SYSDEF   - Set system defaults
 6 ICFUSER  - Use Information Center Facility user services
 7 COURSES  - Maintain education services
 8 PDF      - Use ISPF/PDF services
 9 PROBLEM  - Use problem reporting services
 I INTRO    - Learn to use the Information Center Facility
 T TUTORIAL - Read detailed descriptions of options on this panel
 X EXIT     - Exit

To view PF key definitions, type KEYS on COMMAND or OPTION line of any panel.
```

Figure 1. Main Menu Panel for Administrator Tasks

In addition to those options for administrative tasks, your main menu panel probably has options for:

- The main menu panel for user tasks, to give you access to services available to users, as well as allow you to check information or options you have added or changed.
- The Interactive System Productivity Facility/Program Development Facility, to let you use ISPF/PDF. From this facility, you can invoke the APPC/MVS administration dialog, which gives you access to the functions provided by the APPC/MVS administration utility. See “Administering APPC/MVS Information” on page 7 for a brief description of these functions.

- The administrator tutorial, to provide you with instructions about performing particular administrative tasks. You can read detailed information about the fields on a particular panel while using that panel by pressing the HELP PF key.
- The EXIT option, to take you out of the Information Center Facility and out of ISPF/PDF. When you exit, the system processes any log or list data sets created during your session using the preset (default) information in your profile. To return to the Information Center Facility, wait for the word READY to appear and type ICQICF below it. (ICQICF is the default command; your installation might have changed it.)

Messages

While using the Information Center Facility, you can receive three types of messages:

- Information Center Facility messages
 - Informational
 - Error
- Short error messages from ISPF
- User/system messages

Information Center Facility Messages

Information Center Facility messages provide feedback about the work you are doing. If your COMMAND/OPTION line is at the top of the panel, the message appears below it. If your COMMAND/OPTION line is at the bottom of the panel, the message appears above it.

For an explanation of a message, you can press the HELP PF key or type HELP on the COMMAND/OPTION line while the message is displayed. You can also look up the explanation in *z/OS TSO/E Messages*. To locate the explanation in the book, use the 8-character ID that follows the message, for example ICQAN100.

- *Informational* messages, such as messages reporting that a task completed successfully, generally require no response:

The news item was added. ICQAN402

Some messages, however, tell you how to retry your request:

Resource in use. To retry, press ENTER; to cancel, END. ICQCA141

- *Error* messages from the Information Center Facility report errors that you must correct before you can continue. Some errors you can correct yourself, such as mistakes in typing information on a panel. Other errors are system-related and require help from a system programmer. A message that reports an error you cannot fix instructs you to get help. For example:

Request failed; system error. Press HELP. ICQAN100

Some messages say to contact an administrator. Usually, these messages are displayed when the situation requires an experienced person. You can then take note of the explanation and, if necessary, give that explanation to a system programmer.

Short Error Messages

You might occasionally see short error messages to the right of the panel title. They generally report errors you can correct, for example:

```
"DOWN" IS NOT ACTIVE.
```

Help is available for short error messages also. The help is a one-line explanation of the error:

```
THE COMMAND OR PF KEY ENTERED IS NOT DEFINED.
```

User/System Messages

Messages from the operator, another user, or the system cause the panel you are looking at to be temporarily replaced by the message and three asterisks below it. For example:

```
The system will shut down at 23:00 tonight.  CN(01)
***
```

After reading the message, press the Enter key to resume what you were doing. None of your work is lost.

Using the ISPF/PDF Editor

You need to use the ISPF/PDF editor to perform some administrative tasks, such as adding and modifying news items and course abstracts. The system invokes ISPF/PDF and begins the edit session for you. You simply type in the information on the panel that is displayed.

The ISPF/PDF editor has simple commands for inserting, deleting, copying, moving, and splitting lines. If you are unfamiliar with these commands, you might want to read the section of the online ISPF/PDF tutorial that describes them.

To see the editing information in the ISPF/PDF tutorial, either:

- Press the HELP PF key twice while a panel that allows you to type text is displayed.
- Select the PDF option on the main menu panel for administrators (Figure 1 on page 4). The PDF option invokes ISPF/PDF and displays the first ISPF/PDF panel. Select the TUTORIAL option on that panel. A few pages into the tutorial you see a table of contents and can select the EDIT option.

Displaying PF Key Definitions

You can see the commands associated with the program function (PF) keys at any time. Simply type KEYS on the COMMAND/OPTION line of any panel and press the Enter key. You might want to write down the command each PF key issues and keep the list beside your terminal for quick reference, or if it is provided, use a template for the PF keys.

The online tutorial for administrators describes the function each command performs. To read about the program function keys in the tutorial:

- On the main menu panel, select the TUTORIAL option. You see a panel showing the table of contents for the administrator tutorial.
- On the panel showing the tutorial table of contents, select the INTRO option. You see a menu panel for reading about using the tutorial.
- On the menu panel for reading about using the tutorial, select the PFKEYS option.

Using Commands

Some commands to keep in mind while using the Information Center Facility are:

KEYS Use KEYS to display the PF key settings. You can type KEYS on the COMMAND/OPTION line of any Information Center Facility panel.

ADMIN

Use ADMIN to display the main menu panel for administrators (Figure 1 on page 4) without exiting the service you are using. You can then select and use other services. To return to the panel on which you typed ADMIN, press the END or RETURN PF key one or more times. You can type ADMIN on the COMMAND/OPTION line of any Information Center Facility panel.

IC Use IC to display the main menu panel for users without exiting the service you are using. The IC command is similar to the ADMIN command in that you can temporarily leave one service and go to one or more other services, but you must always return through the route you came. You can type IC on the COMMAND/OPTION line of any Information Center Facility panel.

GO Use GO together with the keyword of an option to go to that option. For example, you can type go enroll on the COMMAND/OPTION line of any Information Center Facility panel to go directly to the ENROLL option.

AMSELECT

Use AMSELECT from outside the Information Center Facility together with the keyword of an Information Center Facility option to go to that option. For example, you can type amselect enroll at the READY mode message or tso amselect enroll on an ISPF/PDF panel to go directly to the ENROLL option.

AMSELECT and GO select only products and services that were defined by Application Manager. They do not select the options DESCRIBE, TUTORIAL, and EXIT.

In addition, you can use:

- Any valid ISPF or TSO/E command or subcommand. Note that, to enter TSO/E commands, you must type tso and a blank before the command. You can also enter any of the commands the PF keys are set to issue, such as END or HELP, on the COMMAND line instead of using the PF key.
- Commands mentioned in panel instructions, such as:

NEW The NEW command displays news items added since you last viewed news. NEW is valid only on the first menu panel for news.

CANCEL

The CANCEL command discards changes you made but do not want to save. CANCEL is not valid on all panels. Panel instructions tell you when you can use it.

Administering APPC/MVS Information

The Information Center Facility also provides access to the APPC/MVS administration dialog. The APPC/MVS administration dialog is an ISPF panel interface that invokes the APPC/MVS administration utility, allowing you to administer APPC/MVS information. Using a series of panels, you can define transaction program profiles, side information, and data base tokens to the system.

Administering the Information Center Facility

A *transaction program profile* contains identification, security, and scheduling information for a target transaction program residing in MVS™. Each transaction program profile consists of a profile key, a program attributes section, and a transaction scheduler section.

Side information contains the translation of a symbolic destination name that can be used on outbound allocate requests. When source transaction programs in MVS issue an outbound allocate request, they can specify a symbolic destination name that represents the transaction program name, logon mode, and partner transaction program name on the allocate call.

The *data base token* represents the system file name. Using data base tokens allows your installation to protect individual transaction programs within a single VSAM data file.

The APPC/MVS administration dialog:

- Lets you add, edit, copy, browse, and delete transaction program profiles and side information, as well as add aliases for transaction program profiles. It also allows you to change the data base token associated with the system data file.
- Performs some data validation and formats information the user enters onto panels into an input request to the APPC/MVS administration utility.
- Provides output (such as confirmation and error messages, transaction program profile and side information listings) to the TSO/E user when the APPC/MVS administration utility is completed. The output is copied to the TSO/E user's ISPF log data set, where the TSO/E user can print or browse the output.

The APPC/MVS administration dialog can be installed in the Information Center Facility using Application Manager and the installation file provided by TSO/E. Or, it can be invoked as a REXX exec from any ISPF panel if the Information Center Facility is installed.

For detailed information on the APPC/MVS administration dialog, including how to maintain transaction program profiles, transaction program profile aliases, side information, and data base tokens, refer to *z/OS MVS Planning: APPC/MVS Management*.

Exiting from the Information Center Facility

To exit from any Information Center Facility panel, press the END PF key or the RETURN PF key. On main menu panels, you can either select the EXIT option or press the END or RETURN PF key.

To return to the Information Center Facility after exiting, wait for the word READY to appear and type ICQICF below it. (ICQICF is the default command; your installation might have changed it.)

Part 2. Administering TSO/E

The TSO/E administrator is responsible for defining users to TSO/E and for maintaining those user definitions.

Chapter 2, “Defining Users to TSO/E,” on page 11, describes the ways to define users to TSO/E and suggests the best way for various situations.

Chapter 3, “Using the ACCOUNT Command,” on page 15, describes how to use the ACCOUNT command to list, add, change, and delete user definitions in TSO/E.

Chapter 2. Defining Users to TSO/E

Overview of Defining Users to TSO/E

There are several ways to define users to TSO/E. Depending on the products available at your installation and how your installation is set up, you can use:

- The ENROLL option of the Information Center Facility
- RACF commands
- The TSO/E ACCOUNT command

Selecting a User ID

TSO/E and the z/OS operating system require that each user be assigned a unique user ID. This ID must be unique to the system's node, but can be a duplicate of another ID used by another node. The ID can either be chosen by the user or the system administrator depending on your installation's administrative guidelines. However, a number of operating system restrictions apply to the ID naming convention; your administrative policy may have defined others.

A user ID is often the user's name, initials, or department number, or any combination of valid characters you and the user choose with the following restrictions:

- Length - no longer than seven characters
- First character - must be an alphabetic (A through Z) character
- Second through seventh character - any combination of alphabetic (A through Z) and numeric (0 through 9) characters. Special characters are not allowed.
- With JES2 a user ID:
 - Cannot be in the format Rnnnnnn or Nnnnnnn, where nnnnnn is a number in the range 1 through 999999. These identifiers are reserved for JES2-defined remote printers and networking nodes.
 - Should not be in the format Unnnnnn, where nnnnnn is a number in the range 1 through 999999. These IDs should be reserved for local JES2 printer definitions; however, the actual range of numbers reserved is specified by your installation and may not be U1-U999999. Contact your JES2 system programmer if you need to define user IDs with this naming convention or refer to the LOCALNUM parameter on the JES2 OUTDEF initialization statement in *z/OS JES2 Initialization and Tuning Reference*.

When using education services in the Information Center Facility, a user ID of EQ is not allowed. The system programmer must provide a different user ID for any user of education services with that ID.

Ways to Define Users

The following chart suggests ways to define users to TSO/E depending on the level of RACF at your installation.

Table 1. Suggestions for Defining Users to TSO/E

Task	With RACF	Without RACF
To add a few users	Use the ENROLL option	Use the ENROLL option

Ways to Define Users

Table 1. Suggestions for Defining Users to TSO/E (continued)

Task	With RACF	Without RACF
To add a large number of users	Use RACF ADDUSER TSO command in a CLIST	Use ACCOUNT ADD command in a CLIST
To modify a user definition	Use the ENROLL option	Use the ENROLL option
To delete a user from TSO/E	Use RACF ALTUSER NOTSO command	Use ACCOUNT DELETE command

ENROLL Option

The Information Center Facility ENROLL option uses panels to gather information about a user you want to define to TSO/E. The ENROLL option relies on the USERTYPE option, which defines classes of users. Associated with each user type is the information necessary to define a user to TSO/E and define the type of access the user has to system resources. When you choose the ENROLL option, you supply unique information about the user as well as the user type.

Using the ENROLL option to add users has the following advantages:

- You can define users to both TSO/E and RACF at the same time, no matter what level of RACF is used at your installation.
- You can easily define users to the VSAM master catalog.
- You can include information about the user in the Information Center Facility names directory.
- You can easily add an ISPF/PDF user profile from the ENROLL option.

To enroll users in RACF, certain RACF resources must be defined for the users. To define those resources, you must issue authorized RACF commands. If you do not have authority, have your system programmer issue them. For more information about RACF resources and how to define them, see *z/OS Security Server RACF Security Administrator's Guide*.

Your installation can use security labels if RACF is installed. To define security labels for users, you must use RACF commands. The Information Center Facility does not support security labels. See *z/OS Security Server RACF Security Administrator's Guide* for information about defining security labels for users. For more information about defining users through the Information Center Facility, see Chapter 7, "Enrolling Users Through the Information Center Facility," on page 55 and Chapter 8, "Maintaining User Type Definitions," on page 63.

RACF Commands

If your installation has RACF active, you can use RACF commands to define users to both TSO/E and RACF, and maintain those definitions in the RACF data base. The RACF commands are:

- ADDUSER TSO – To add a new user to TSO/E.
- ALTUSER TSO – To change information about a previously-defined user.
- ALTUSER NOTSO – To remove a user from TSO/E.
- LISTUSER TSO – To list information from the RACF data base about a user.

Using the RACF commands to add and maintain users has the following advantages:

- You can use one set of commands to add, change, or delete information about TSO/E user IDs and RACF security.

- You need maintain only one data set, the RACF data base, for user information.

For more information about RACF commands, see *z/OS Security Server RACF Command Language Reference*. For information about adding users to the RACF data base, see *z/OS Security Server RACF Security Administrator's Guide*.

Converting to the RACF Data Base

If you have information about users in both the UADS and the RACF data base, you can merge the information into the RACF data base with the RACONVRT command. You can then maintain the one data base with RACF commands. For more information about using the RACONVRT command, see *z/OS TSO/E Customization*.

Defining Aliases in the Master Catalog

If you define aliases in the master catalog for user IDs referring to user catalogs, distribute new user IDs and their corresponding passwords after the aliases have been defined. For information on defining aliases, refer to *z/OS DFSMS Access Method Services Commands*.

TSO/E ACCOUNT Command

The ACCOUNT command and its subcommands define users to TSO/E and maintain those definitions in the user attributes data set (UADS). If you do not have the Information Center Facility or RACF, you must use the ACCOUNT command to define users to TSO/E. For more information about using the ACCOUNT command, see Chapter 3, "Using the ACCOUNT Command," on page 15.

Note

When using a command to enroll users (either the RACF commands or the ACCOUNT command), you can easily add a large number of users by putting the command in a CLIST and running the CLIST in the background. For information about writing CLISTs, see *z/OS TSO/E CLISTs*.

Ways to Define Users

Chapter 3. Using the ACCOUNT Command

Overview of Using the ACCOUNT Command

You can use the ACCOUNT command and its subcommands to define users to TSO/E. When you use the ACCOUNT command, user definitions are stored in the user attributes data set (UADS) and can include:

- The user ID
- Passwords associated with the user ID
- Account numbers associated with the passwords
- LOGON procedure names associated with the account numbers and other attribute information associated with the LOGON procedures

You can use the ACCOUNT command and its subcommands to maintain user definitions in the UADS. Some of the maintenance tasks are:

- Listing the user definition (LIST subcommand)
- Adding users (ADD subcommand)
- Deleting users (DELETE subcommand)
- Changing information in a user definition (ADD, DELETE, and CHANGE subcommands)

The remainder of this chapter covers the basic tasks of defining and maintaining user definitions with the ACCOUNT command. Your installation might have written programs to help you maintain user IDs, so you might not need to use the ACCOUNT command directly. If you must use the ACCOUNT command directly, see *z/OS TSO/E System Programming Command Reference* for the complete syntax of the ACCOUNT command and its subcommands.

Structure of UADS Entries

Each entry in the UADS must contain:

- A user ID
- A password, or a null field
- An account number, or a null field
- A procedure name

An entry containing only required information would have the following structure:

Structure of UADS Entries

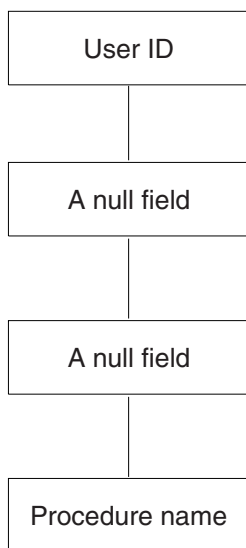

Figure 2. The Simplest Structure for a UADS Entry

A more complicated entry, with several passwords, account numbers, and LOGON procedures, might have the following structure:

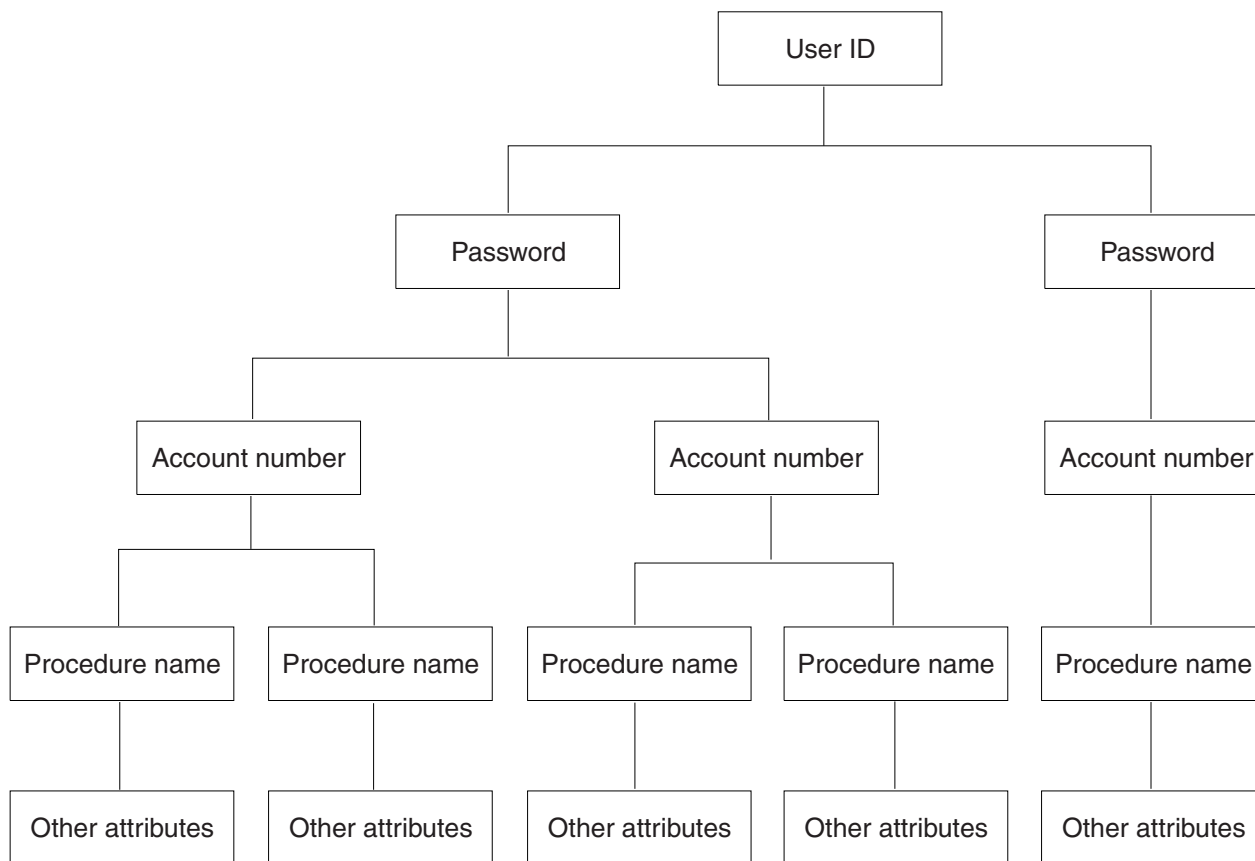

Figure 3. A More Complex Structure for a UADS Entry

The information in a UADS entry forms a tree structure. When specifying information to be added, changed, or deleted, all information (such as password, account number, and procedure name) below the level specified is affected. Thus, if

you specify that you want to delete a password, all the account numbers and procedures under that password are also deleted.

Using ACCOUNT Subcommands

When you maintain user IDs with the ACCOUNT command, you actually use the ACCOUNT subcommands. The subcommands you use most frequently are:

- LIST – to display information about a user in the UADS.
- ADD – to add a new user or add information about an existing user.
- DELETE – to delete a user or delete information about a user.
- CHANGE – to change existing information about a user

Each of these subcommands has positional parameters for specifying the information to be maintained. The order of the parameters is the same for each subcommand:

1. User ID
2. Password
3. Account number
4. LOGON procedure

Example

The ACCOUNT subcommand to add a user with user ID USER5, a password of NEW5, an account number of 7653, and the LOGON procedure PROC00, is as follows:

```
ADD (user5 new5 7653 proc00)
```

You can use the ADD, CHANGE, and DELETE subcommands to maintain either entire entries or parts of entries. When you are maintaining entire entries (adding, changing, or deleting user IDs), you need to supply only the user ID, in parentheses, with the subcommand. When you are maintaining parts of the entries, you must identify what parts of what entries you want to change.

When you use the ADD, CHANGE, or DELETE subcommand to modify part of an existing entry in the UADS, the subcommand is divided into two segments: positional parameters (the nodelist) and keyword parameters. Positional parameters indicate where the modification is to occur. Keyword parameters supply the information to be added, changed, or deleted.

```
subcmd (userid password acctnum) data(datanum )
           └──────────────────┘ └──────────┘
           positional parameters  keyword parameters
```

Figure 4. A Subcommand for Modifying Part of a UADS Entry

In Figure 4, the positional parameters supply the user ID, password, and account number under which the modification is to occur. The way the keyword parameters are interpreted depends on the subcommand. If the subcommand is ADD, *datanum* is added as a LOGON procedure under the account number. If the subcommand is DELETE, *datanum* is a LOGON procedure to be deleted. If the subcommand is CHANGE, the account number is renamed to *datanum*.

For subcommands ADD and CHANGE, you can supply additional attributes. These attributes are described in “Adding a User Definition” on page 19.

Using ACCOUNT Subcommands

1. Log on to TSO/E with a user ID that has account authority and allocate SYS1.UADS to the ddname SYSUADS as SHR in the LOGON procedure or in your TSO/E session.
2. If you are modifying an existing user ID, the user with that ID must be logged off. You might need to send a message to the user asking the user to log off.
3. Type ACCOUNT.
4. You then see the ACCOUNT mode message and can enter ACCOUNT subcommands.

To leave ACCOUNT: Type the END subcommand and press the Enter key.

For Help with ACCOUNT Subcommands

If you need help while under ACCOUNT, you can use the HELP subcommand of ACCOUNT to see information about a subcommand. To see all of the help information for a subcommand, enter:

```
help subcommand_name
```

For more information about using the HELP subcommand, see *z/OS TSO/E System Programming Command Reference*.

Listing Information about UADS Entries

When you are maintaining user IDs, you might occasionally need to know something about an entry or group of entries in the UADS. You can find this information using the LIST and LISTIDS subcommands of ACCOUNT.

The LISTIDS subcommand has no parameters. When you enter LISTIDS, you see a list of the user IDs in the UADS. No other information from the UADS entries is displayed.

The LIST subcommand has four positional parameters in the following order: the user ID, the password, the account number, and the LOGON procedure. You can set each of these parameters to either a specific value or an asterisk. Specific values limit the information you receive. For example, to see all the account numbers and LOGON procedures under password **MYPSWORD** for user ID **MYID**, you would enter:

```
list (myid mypsword)
```

When you do not set all four parameters, the remaining parameters are set to asterisks automatically. The LIST subcommand in the previous example would display the same information as the following:

```
list (myid mypsword * *)
```

If you do not want to limit the information you receive for one or more of the parameters, substitute an asterisk. For example, to see all the user IDs using LOGON procedure LOGPROC, you would enter:

```
list (* * * logproc)
```

Examples

List All User IDs in the UADS:

```
listids
```

List All UADS Information:

list (*)

List IDs Associated with an Account Number: List all user IDs with account number **DEPT34**.

list (* * dept34)

List Information Associated with a LOGON Procedure Under a User ID: List all passwords and account numbers associated with LOGON procedure **PROC00** under user ID **MYID**.

list (myid * * proc00)

Display All Information for a User ID: List all information in the UADS for user ID **MYID**.

list (myid)

Adding a User Definition

When you add a user ID, you must supply:

- The user ID
- A password, or an asterisk to indicate a null field
- An account number, or an asterisk to indicate a null field
- A LOGON procedure

Note: If you set the password or account number to an asterisk, you *cannot* later add a password or account number by using the **CHANGE** subcommand. On any future **ACCOUNT** subcommands, you must use asterisks in place of the password and account number for that user ID.

You can also supply the following attributes:

MAXSIZE

The maximum region size that a user can request when logging on. If you set **MAXSIZE** to 0, or do not supply a maximum region size, TSO/E does not restrict the region size. **MAXSIZE** specifies the maximum number of 1024-byte units of virtual storage the system assigns to a user.

SIZE The minimum region size, used if the user does not request a specific region size when logging on. **SIZE** specifies the minimum number of 1024-byte units of virtual storage the system assigns to a user. If you set **SIZE** to 0, or do not supply a minimum region size, TSO/E uses the minimum region size set by your installation. If you set **SIZE** larger than the maximum region size for the user ID, TSO/E resets **SIZE** to the maximum.

UNIT The default specification of a device type when the user allocates data sets, but does not specify a volume.

ACCT Allows the user to use the **ACCOUNT** command.

DEST Allows dynamically allocated **SYSOUT** data sets to default to the remote destination for processing. If you do not supply **DEST**, the user must route **SYSOUT** data sets explicitly for processing.

JCL Allows the user to use the commands **SUBMIT**, **STATUS**, **CANCEL**, and **OUTPUT**.

MOUNT

Allows the user to make allocation requests that require volume mounting.

Adding a User Definition

OPER Allows the user to use the OPERATOR command.

HOLD

Allows the job output from a job submitted with the HOLD keyword on the SUBMIT command to be placed in the hold queue.

JOBCLASS

The default job class for jobs submitted without a JOB statement. If you do not supply JOBCLASS, JES2 or JES3 assigns the default job class.

MSGCLASS

The default output class for jobs without a JOB statement or without the specification of the MSGCLASS parameter on the JOB statement, and if the job was submitted with the NOHOLD keyword on the SUBMIT command. If you do not supply MSGCLASS, JES2 or JES3 assigns the default output class.

SYSOUT

The default SYSOUT class if you do not specify a class with the SYSOUT keyword on the ALLOCATE command.

RECOVER

Allows the user to use the EDIT recovery facility.

PERFORM

Allows the user to request a performance group when logging on.

USERDATA

Two hex bytes of installation-defined data. Your installation might use USERDATA to pass information to a LOGON pre-prompt exit.

Examples

Simplest UADS Entry: Add the user ID **USER1**, and have the user ID use **PROC00** as a LOGON procedure. Do not define a password or account number for USER1.

```
add (user1 * * proc00)
```

Password and Account Number: Add the user ID **USER2**, and have the user ID use **PROC00** as a LOGON procedure. Give the user ID the password **XYZABC**, and associate **PROC00** with the account number **D721234**. Do not assign any minimum region size or any device to the LOGON procedure.

```
add (user2 xyzabc d721234 proc00)
```

MAXSIZE, SIZE, and UNIT: Add the user ID **USER3**, with LOGON procedure **PROC00**, password **XYZABC**, and account number **D721234**. Include the following other attributes:

- **MAXSIZE:** Set to **200**
- **SIZE:** Set to **100**
- **UNIT:** Set to **SYSDA**

```
add (user3 xyzabc d721234 proc00) maxsize(200) size(100) unit(sysda)
```

DEST, HOLD, JOBCLASS, MSGCLASS, and SYSOUT: Add the user ID **USER4**, with LOGON procedure **PROC00**, password **XYZABC**, and account number **D721234**. Include the following other attributes:

- **DEST:** Set to node **NYNET**
- **HOLD:** Set to class **H**
- **JOBCLASS:** Set to class **G**
- **MSGCLASS:** Set to class **A**
- **SYSOUT:** Set to class **A**

```
add (user4 xyzabc d721234 proc00) dest(nynet) hold(h) jobclass(g)+  
msgclass(a) sysout(a)
```

ACCT, JCL, MOUNT, OPER, and RECOVER: Add the user ID USER5, with LOGON procedure PROC00, password XYZABC, and account number D721234. Give the user authority to:

- Use the ACCOUNT command (ACCT)
- Use the SUBMIT, STATUS, CANCEL, and OUTPUT commands (JCL)
- Make allocation requests requiring volume mounting (MOUNT)
- Use the OPERATOR command (OPER)
- Use the EDIT recovery facility (RECOVER).

```
add (user5 xyzabc d721234 proc00) acct jcl mount oper recover
```

PERFORM and USERDATA: Add the user ID USER6, with LOGON procedure PROC00, password XYZABC, and account number D721234. Include the following other attributes:

- Allow the user to request one of the performance groups 4, 10, 30, 45, or 100 (PERFORM)
- Pass the data 1F09 (USERDATA).

```
add (user6 xyzabc d721234 proc00) perform(4,10,30,45,100)+  
userdata(1F09)
```

Adding New Information to an Existing User Definition

In addition to using the ADD subcommand to add new entries to the UADS, you can use the ADD subcommand to add new information to existing UADS entries. You would use the ADD subcommand, for example, to add a new account number to a UADS entry.

When you add to an existing entry, you can:

- Add a new password, account number, and LOGON procedure for the user ID
- Add a new account number and LOGON procedure under an existing password
- Add a new LOGON procedure under an existing account number

You *cannot* insert new information into an existing branch of the entry's structure. For example, if a user has been using a LOGON procedure with one account number, and now needs to use an additional account number with the same LOGON procedure, you must add both the new account number *and* the LOGON procedure under the password:

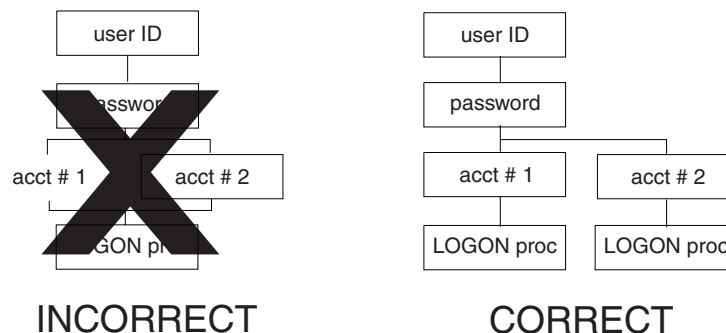

You can use only the following parameters when you are adding to an existing UADS entry:

Adding New Information to an Existing User Definition

- DATA** Supplies the new password, account number, and/or LOGON procedure.
- SIZE** Supplies the minimum region size for the LOGON procedure, if the user does not request a specific region size when logging on. SIZE specifies the minimum number of 1024-byte units of virtual storage the system assigns to a user. If you set SIZE to 0, or do not supply a minimum region size, TSO/E uses the minimum region size set by your installation. If you set SIZE larger than the maximum region size for the user ID, TSO/E resets SIZE to the maximum.
- UNIT** Supplies the default specification of a device type when the user allocates data sets, but does not specify a volume.

Examples

Figure 5 shows the structure of an existing entry in a UADS. The following examples add to the entry. The new structure of the entry is shown with the subcommand used to make the addition.

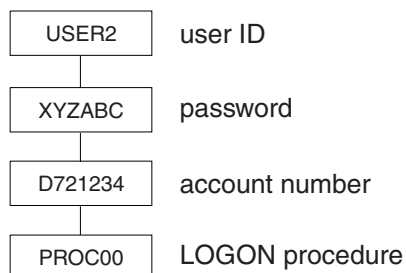
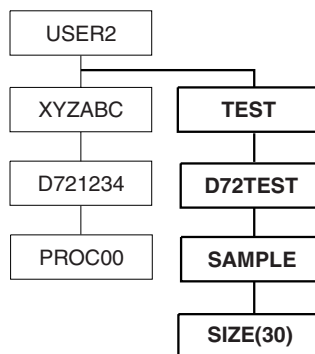

Figure 5. UADS Entry Before Additions

Add a New Password, Account Number, and LOGON Procedure: Add password **TEST**, with account number **D72TEST** and LOGON procedure **SAMPLE**, to user ID **USER2**. Give procedure **SAMPLE** a minimum region size of **30** 1024-byte units of virtual storage.

```
add (user2) data(test d72test sample) size(30)
```



Add a New Account Number: Add account number **D725678** under password **XYZABC**. Associate LOGON procedure **PROC00** with the new account number.

```
add (user2 xyzabc) data(d725678 proc00)
```

Adding New Information to an Existing User Definition

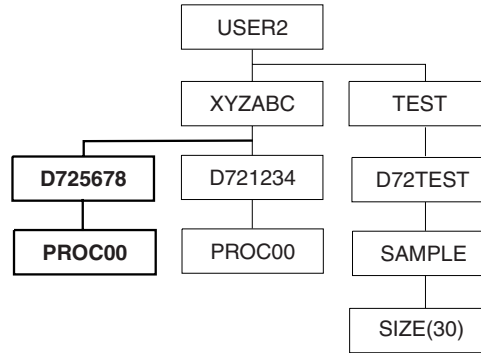

Add a LOGON Procedure Under All Account Numbers: Add LOGON procedure ICFPROC under all account numbers for USER2. Have ICFPROC use device SYSDA as the default for allocation.

```
add (user2 * *) data(icfproc) unit(sysda)
```

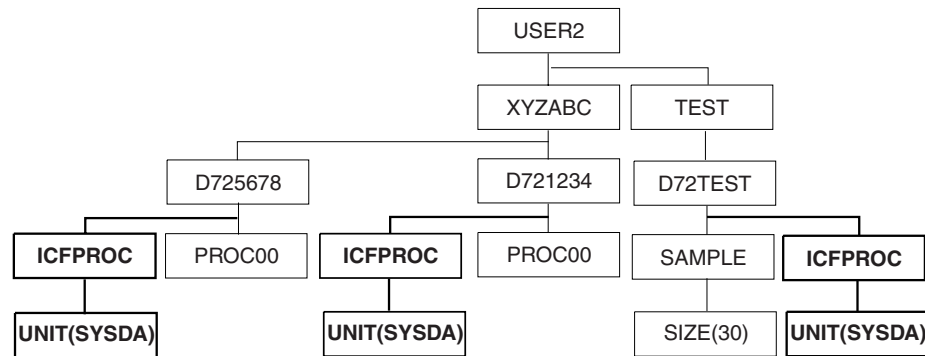

Changing Information in a User Definition

Using the CHANGE subcommand of ACCOUNT, you can change user IDs, passwords, account numbers, and LOGON procedures. (Note that you cannot use the CHANGE subcommand to change passwords or account numbers originally set to asterisks.) You can also change existing attributes by supplying the following attributes:

Attribute	Meaning	Turn Off With:
MAXSIZE	The maximum region size that a user can request when logging on. If you set MAXSIZE to 0, or do not supply a maximum region size, TSO/E does not restrict the region size. MAXSIZE specifies the maximum number of 1024-byte units of virtual storage the system assigns to a user.	NOLIM
ACCT	Allows the user to use the ACCOUNT command.	NOACCT
DEST	Allows dynamically allocated SYSOUT data sets to default to the remote destination for processing. If you do not supply DEST, the user must route SYSOUT data sets explicitly for processing.	NODEST
JCL	Allows the user to use the commands SUBMIT, STATUS, CANCEL, and OUTPUT.	NOJCL
MOUNT	Allows the user to make allocation requests that require volume mounting.	NOMOUNT
OPER	Allows the user to use the OPERATOR command.	NOOPER

Changing Information in a User Definition

Attribute	Meaning	Turn Off With:
HOLD	Allows the job output from a job submitted with the HOLD keyword on the SUBMIT command to be placed in the hold queue.	NOHOLD
JOBCLASS	The default job class for jobs submitted without a JOB statement. If you do not supply JOBCLASS, JES2 or JES3 assigns the default job class.	NOJOBCLASS
MSGCLASS	The default output class for jobs without a JOB statement or without the specification of the MSGCLASS parameter on the JOB statement, and if the job was submitted with the NOHOLD keyword on the SUBMIT command. If you do not supply MSGCLASS, JES2 or JES3 assigns the default output class.	NOMSGCLASS
SYSOUT	The default SYSOUT class if you do not specify a class with the SYSOUT keyword on the ALLOCATE command.	NOSYSOUT
RECOVER	Allows the user to use the EDIT recovery facility.	NORECOVER
PERFORM	Allows the user to request a performance group when logging on.	NOPERFORM
USERDATA	Two hex bytes of installation-defined data. Your installation might use USERDATA to pass information to a LOGON pre-prompt exit.	_____

If you are using the CHANGE subcommand to change a LOGON procedure, the following attributes apply to the new LOGON procedure.

SIZE The minimum region size, used if the user does not request a specific region size when logging on. SIZE specifies the minimum number of 1024-byte units of virtual storage the system assigns to a user. If you set SIZE to 0, or do not supply a minimum region size, TSO/E uses the minimum region size set by your installation. If you set SIZE larger than the maximum region size for the user ID, TSO/E resets SIZE to the maximum.

UNIT The default specification of a device type when the user allocates data sets, but does not specify a volume.

If you use SIZE and UNIT, you must identify the LOGON procedure or procedures to which they apply.

Examples

The following examples show how to change a UADS entry originally created with the ADD subcommand of ACCOUNT:

```
add (user0 mypasswd myacct myproc) maxsize(100) size(50)+
  unit(sysda) acct oper jcl mount recover dest(a) hold(h)+
  jobclass(g) msgclass(a) sysout(a)
```

Change a User ID: Change user ID **USER0** to **MYID**.

```
change (user0) data(myid)
```

Change a LOGON Procedure: Change LOGON procedure **MYPROC** to **NEWPROC**. Set the default region size for **NEWPROC** to **50** and the default unit to **DEPTUNIT**. Change the maximum region size to **200**.

```
change (myid mypasswd myacct myproc) data(newproc) size(50)+
  unit(deptunit) maxsize(200)
```

Change Other Attributes: Change the attributes for user ID **MYID** as follows:

- Turn off attributes **ACCT**, **OPER**, **MOUNT**, **RECOVER**, and **DEST**
- Change the **SYSOUT** class to **H**.

```
change (myid) noacct nooper nomount norecover nodest+
  sysout(h)
```

Changing an Attribute Globally: Make sure all users have the authority to use SUBMIT, OUTPUT, STATUS, and CANCEL.

```
change (*) jcl
```

Deleting Information from a User Definition

Using the DELETE subcommand, you can delete user IDs, passwords, account numbers, and LOGON procedures. When you delete an element in an entry (for example, an account number), all of the information under that element is also deleted. If you delete the only password, account number, or LOGON procedure for a user ID, that user ID is automatically deleted.

Examples

Figure 6 shows the structure of an existing entry in a UADS. The following examples delete parts of the structure. The new structure of the entry is shown with the subcommand used to make the deletion.

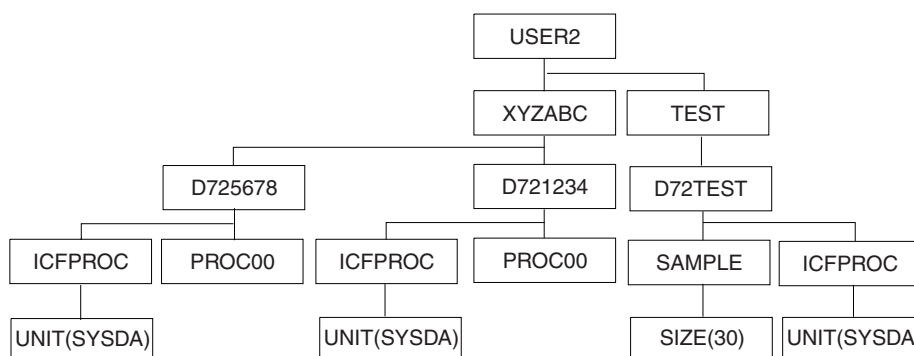
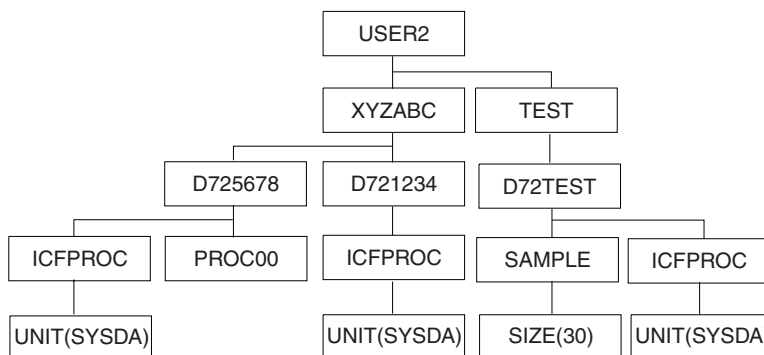

Figure 6. UADS Entry Before Deletions

Delete a LOGON Procedure: Delete LOGON procedure **PROC00** from under account number **D721234**.

```
delete (user2 xyzabc d721234) data(proc00)
```



Deleting Information from a User Definition

Delete an Account Number: Delete account number **D721234** from under password **XYZABC**.

```
delete (user2 xyzabc) data (d721234)
```

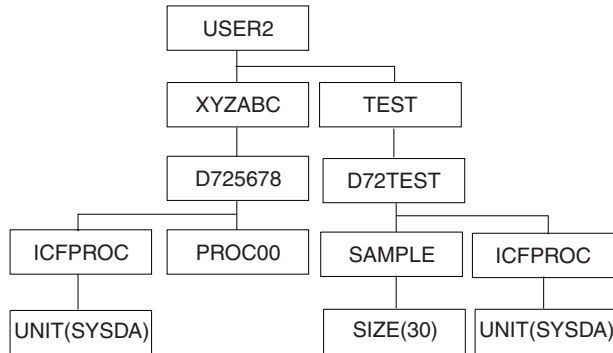

Delete a LOGON Procedure Throughout an Entry: Delete LOGON procedure **ICFPROC** wherever it occurs in the entry for **USER2**.

```
delete (user2 * *) data(icfproc)
```

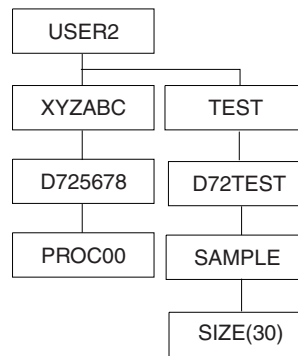

Delete a Password: Delete password **TEST** from under user ID **USER2**.

```
delete (user2) data(test)
```

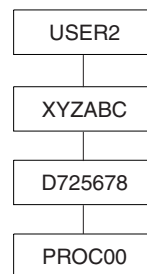

Delete a User ID: Delete user ID **USER2** from the UADS.

```
delete (user2)
```

Part 3. Administering the Information Center Facility

Administering the Information Center Facility consists of maintaining the services within the Information Center Facility. Each chapter in this part covers a standard service the way it is shipped. Your installation might have customized these standard services or added other services.

Chapter 4, “Maintaining the News Service,” on page 29, describes how to view, add, modify, delete, and print online news using the Information Center Facility news service.

Chapter 5, “Maintaining the Names Directory,” on page 35, describes how to maintain the Information Center Facility names directory by viewing, adding, modifying, and deleting names directory entries.

Chapter 6, “Maintaining Courses,” on page 43, describes how you can use the Information Center Facility to provide online course information about both computer and classroom courses.

Chapter 7, “Enrolling Users Through the Information Center Facility,” on page 55, describes how to define users to TSO/E, RACF, and the VSAM master catalog using the enroll service.

Chapter 8, “Maintaining User Type Definitions,” on page 63, describes how to view, add, modify, and delete user type definitions. User types define a class of users and contain specific information used to control access to TSO/E. Administrators assign user types to people when enrolling them through the Information Center Facility.

Chapter 9, “Setting System Defaults: ISPF Profile,” on page 75, describes how to change the model ISPF profile through the Information Center Facility.

Chapter 10, “Setting System Defaults: Printer Support,” on page 77, describes how to create and manage print definitions for your installation's printers through the Information Center Facility.

Chapter 11, “Setting System Defaults: Application Manager,” on page 101, describes how to use Application Manager to add, change, and delete services in the Information Center Facility. You can also view, replace, and upgrade applications, generate a hierarchy display of applications, and create installation files from existing applications.

Chapter 12, “Mass Installation File Processing,” on page 149, describes how to use the mass installation file process to process multiple installation files including the upgrade of these files and to create multiple installation files from a list of applications to be exported.

Chapter 4. Maintaining the News Service

Overview of Maintaining the News Service

Through the news service, Information Center Facility users can read up-to-date news about courses, new products, operational changes, or other topics of interest at their terminals. As a news administrator, you can make news immediately available to users by adding or modifying a news item.

As an administrator, you:

- Add new items
- Modify existing items
- Delete old items
- View news items
- Print news items

Each news item consists of:

- **Category** – The general subject of a news item. The category can be up to 20 characters long.
- **Item** – The title or headline of the news item.
- **Begin Date** – The first day users can read the news item.
- **End Date** – The last day users can read the news item.
- **Priority** – Y (yes) or N (no) to indicate whether the news is of major importance.
- **Text** – The content of the news.

Users can use the category, the item or title, and the date to see subsets of news items. Therefore, it is important that you follow conventions for these fields. Before creating the first news item, determine the number and type of category names to use. Decide also the kinds of news that are priority news.

Before You Begin

Before you begin maintaining the news service, read the online tutorial. The tutorial describes how to perform the tasks for maintaining the news service. To read the tutorial:

1. On the main menu panel for administrators, select the option for maintaining the news service.
2. Type T on the COMMAND line of the first news panel, and press the Enter key.

For detailed information about using a particular panel, press the HELP PF key while you are on that panel.

Maintaining News Items

1. Select the option for maintaining the news on the main menu panel.
2. Do one of the following:
 - Supply enough information about the news item on the first panel for news to identify the item.
 - Request a list.
To see a list of all the names, leave the asterisk (*) or blanks in each field. (Blank fields default to an asterisk.) To see only news meeting certain

Maintaining News Items

conditions, supply information to restrict the list. For example, for a list of news items added on or after June 10, 1987, you would supply the following:

```
ICQANE00          INFORMATION CENTER FACILITY - NEWS
COMMAND ==>>

To take the tutorial for NEWS, type T on the COMMAND line. For a list of new
news items, type NEW on the COMMAND line. To view, modify, copy, or delete a
news item, type the information where requested.
To add a news item, type A on the COMMAND line.

CATEGORY          ==>> * _____ Name (or part with * suffix)
ITEM              ==>> * _____ Name (or part with * suffix)
BEGIN DATE        ==>> 6/10/87_ (mm/dd/yy) Earliest date of news item(s),
or *
PRIORITY          ==>> * (Y/N/*) Priority item, non-priority item,
or either
```

If a list is too long to fit on one panel, press the UP and DOWN PF keys to go backward and forward in the list. All priority items appear before non-priority items. Within each group, priority or non-priority, the most recent news items appear first. If there is more than one news item for a given date, the items are alphabetized by category name and then by item name.

3. Type V, C, M, or D next to an existing news item to view, copy, modify, or delete it. To add a news item, type A on the COMMAND line and press the Enter key.

Printing a News Item

You can print a news item from the List of News Items panel and from the View a News Item panel. The printer that you select must be defined to the Information Center Facility or the print request cannot be completed. See Chapter 10, "Setting System Defaults: Printer Support," on page 77, for more information about defining printers to the Information Center Facility.

To print a news item

1. To print a news item from the List of News Items panel, type P to the left of the news item. To print a news item from the View a News Item panel, type P on the COMMAND line. Press the Enter key.

The Printer Specification panel appears. Figure 7 shows the Printer Specification panel.

```
ICQCNE30          Information Center Facility - Printer Specification
COMMAND ==>>>

Type the information where requested and press ENTER.

Printer Location ==>> * _____ Printer location or *
Print Format      ==>> * _____ Document format or *
Printer Type     ==>> * _____ Printer type or *

Number of copies ==>> 1                               Specify 1 to 255 copies
```

Figure 7. Printer Specification Panel

2. You can either specify a particular printer, or obtain a printer selection list. Specify a particular printer on the printer selection entry lines, or type a partial

value with an asterisk (*) suffix, or an asterisk (*) by itself on any of the three data entry fields to obtain a list of available printers.

A previously-selected printer, if any, remains as the default until you change the printer identification.

3. Use the NUMBER OF COPIES field to request several copies of the news item. The default for the number of copies is 1.

Viewing a News Item

To view

Type a V in the field to the left of the news item and press the Enter key. If the news item does not fit on the screen press the UP and DOWN PF keys to scroll backward and forward.

To end viewing

Press the END PF key.

Viewing a New Item of News

New news items are items added since you last viewed news. If new news items have been added, you see a message telling you that there are new items when you first enter the Information Center Facility.

To view new news items

1. Type NEW on the COMMAND line of the first news service panel and press the Enter key. You see a list of new items only.
2. Type a V in the field to the left of the item you want to view, and press the Enter key.

To end viewing

Press the END PF key.

Adding a News Item

You can add a news item by either:

- Creating a new item, or
- Copying an existing news item and then changing it for the new item

Creating a New Item

To create a new item: Type A on the COMMAND line of the first news service panel or the list panel and press the Enter key. Supply the description of the news item you want to add. You must fill in the ITEM, BEGIN DATE, and PRIORITY fields. Make the begin date either the current date or a future date, so that end users and administrators are properly notified of the new items. To make an item available indefinitely, leave the END DATE field blank.

To save the new item: Press the Enter key on the panel for adding a news item. After you press the Enter key, you see a panel on which you can supply text for the news item.

To cancel creating a new item: Press the END PF key on the panel for adding a news item.

To supply text for the item: Type the text of the news on the panel for adding text to the news item. (For information on typing text using the ISPF/PDF editor, read the ISPF online tutorial.)

Maintaining News Items

To save the text of the news item: Press the END PF key.

To cancel adding text to the news item: Type CANCEL on the COMMAND line and press the Enter key. The news item is added as an item without text.

Copying an Existing News Item

If a news item exists that is similar to one you want to add, you can copy the existing item and change it to create the new item.

To copy a news item: Type C next to the news item you want to copy, and press the Enter key. Update the old description for the new news item. You must change at least one of the CATEGORY, ITEM, BEGIN DATE, or PRIORITY fields.

To save the new item: Press the Enter key on the panel for adding a news item. After you press the Enter key, you see a panel showing the text of the copied news item.

To cancel creating a new item: Press the END PF key on the panel for adding a news item.

To change the text for the new item: Type over the text of the old news item where required.

To save the text of the news item: Press the END PF key.

To cancel adding text to the news item: Type CANCEL on the COMMAND line and press the Enter key. The news item is added as an item without text.

Modifying a News Item

To modify

Type M in the field to the left of the news item you want to modify and press the Enter key. You then see the description of that item.

To change the description for the item

Type over the parts of the description you want to change on the panel for modifying the description of a news item. If you want to modify the text of the news item, leave Y (for yes) in the MODIFY TEXT field. If you don't want to modify the text, type N (for no).

To save changes to the description

Press the Enter key on the panel for modifying the description.

To cancel modifying the item

Press the END PF key on the panel for modifying the description.

To modify the text of the item

If you left the MODIFY TEXT field set to Y, you see the text. Type your changes over the existing text as required.

To save changes to the text

Press the END PF key on the panel for modifying the text.

To cancel changing the text

Type CANCEL on the COMMAND line of the panel for modifying the text, and press the Enter key.

Deleting a News Item

To delete

Type a D next to the news item you want to delete. You then see the delete confirmation panel.

To view before deleting

Leave Y (for yes) in the VIEW ITEM BEFORE DELETE field and press the Enter key.

To end viewing

Press the END PF key. You return to the delete confirmation panel. The VIEW ITEM BEFORE DELETE field is reset to N (for no).

To confirm the deletion

Type N in the VIEW ITEM BEFORE DELETE field if it is not set to N already, and press the Enter key.

To cancel the deletion

Press the END PF key.

Maintaining News Items

Chapter 5. Maintaining the Names Directory

Overview of Maintaining the Names Directory

The names directory contains information about both individuals and groups of people. A group might contain the names of everyone in a department. Each set of information about a person or a group is an *entry*.

A user can use the names directory directly, to see information about other people, or indirectly, through Information Center Facility services. As an administrator, you maintain a master copy of the names directory that all users can view. Users can request that you add, modify, or delete entries in the master directory. Users also have private directories that they maintain.

When you finish changing the master names directory, update the master NAMES.TEXT data set for TRANSMIT and RECEIVE. TRANSMIT and RECEIVE can then use the changes you made to the master names directory.

Each entry for an individual can contain:

- Name
 - Last name (required)
 - First name
 - Nickname
 - Middle name
 - Suffix (such as Jr., III, Ph.D.)
 - Title (such as Mr., Mrs., Dr.)
- Address
 - Internal address
 - External address
- Telephone number
- Job title
- Department
 - Name of department
 - Number of department
- IDs
 - Directory ID (required) – a unique “nickname” to identify a person
 - User ID
 - System node
 - DISOSS user ID (for users in a DISOSS system)
 - DISOSS system
- User type (for example, administrator or user)

Each entry for a group can contain:

- Group name (required)
- Description of the group
- List of entries in the group

Groups can be made up of names of individuals and names of other groups.

To make entries in the directory similar, decide with any other names administrators the format and content of each field in an entry.

Overview of Maintaining the Names Directory

Before You Begin

Before you begin maintaining the names directory, read the online tutorial. The tutorial describes how to perform the tasks for maintaining the names directory. To read the tutorial, select:

1. The option for maintaining the names directory on the main menu panel for administrators
2. The TUTORIAL option on the Names Directory Menu panel.

For detailed information about using a particular panel, press the HELP PF key while you are on that panel.

Note: Sometimes, to improve performance, an installation customizes the names directory to leave open the ISPF tables containing names. If you update the master names directory while the tables are open, users do not see the updates immediately. Users see the updated tables only after they do one of the following:

- Close the tables by selecting the CLOSE option on the user names menu panel
- Exit to the TSO/E READY message
- Log off

Maintaining Names in the Master Directory

1. On the main menu panel, select the option for maintaining the names directory.
2. On the Names Directory Menu panel, select the NAMES option.
3. Do one of the following:
 - On the name identification panel, supply enough information about the name to uniquely identify the name.
 - Request a list.

To see a list of all the names in the directory, leave the asterisk (*) or blanks in each field. (Blank fields default to an asterisk.) To see only names meeting certain conditions, supply information to restrict the list. For example, for a list of names beginning with "Sm", you would supply the following on the Names Identification panel:

```
ICQAAE10          NAMES - NAME IDENTIFICATION
COMMAND ==>>>

To find, modify, or delete a name, type the information where requested.
All information is optional. To request a list, "*" may be used.
To add a name, type A on the COMMAND line.

  LAST NAME          ==>> sm* _____
  FIRST OR NICKNAME  ==>> * _____
  USER ID           ==>> * _____

Additional search information
  DEPARTMENT NUMBER ==>> * _____
  DEPARTMENT NAME   ==>> * _____
  JOB TITLE         ==>> * _____

  DIRECTORY ID      ==>> * _____ Unique identifier for names directory
  SYSTEM NODE       ==>> * _____ System ID used for electronic mail
  USER TYPE        ==>> * _____ User type for Information Center Facility
```

If a list is too long to fit on one panel, press the UP and DOWN PF keys to go up and down the list.

4. To view, modify, or delete an existing name, type V, M, or D next to it. If the name you are looking for does not exist, you can add it by typing A on the COMMAND line and pressing the Enter key.

Viewing a Name

To view

Type a V in the field to the left of the name and press the Enter key. The information for the name is displayed on two panels.

To see the second panel

Press the Enter key.

To return to the first panel

Type BACK on the COMMAND line, and press the Enter key.

To end viewing

Press the Enter key on the second panel.

Modifying a Name

When you modify a name, the name is also modified in all groups in the master directory that include it. You do not need to modify the name in the groups.

To modify

Type an M in the field to the left of the name and press the Enter key. The information for the name is displayed on two panels.

To change information

Type over existing information, or add new information in blank fields. Remember to follow the conventions of your installation regarding content and format.

To see the second panel

Press the Enter key.

To return to the first panel

Type BACK on the COMMAND line, and press the Enter key.

To save changes

Press the Enter key on the second panel.

To cancel changes

Press the END PF key on either panel.

Deleting a Name

When you delete a name, it is removed from the master directory and from all groups in the master directory that include it. You do not need to delete the name from the groups. The name is not removed from users' private directories.

To delete

Type a D in the field to the left of the name and press the Enter key. After you press the Enter key, you see a panel asking you to confirm that you want the name deleted.

To confirm the deletion

Press the Enter key.

Maintaining Names in Master Directory

To cancel the deletion

Press the END PF key.

Adding a Name

You do not need to add to the names directory the name of a person enrolled in the Information Center Facility. When a person is enrolled, that person's name is added automatically to the names directory. You might want to add the names of some people not enrolled in the Information Center Facility to the names directory.

To add

Type A on the COMMAND line of the Name Identification panel or on the panel showing a list of names, and press the Enter key. You see the first of two panels on which you can supply information about the name.

To see the second panel

Press the Enter key.

To return to the first panel

Type BACK on the COMMAND line, and press the Enter key.

Information to supply

You must supply a last name and a directory ID. (The directory ID is a unique identifier of up to seven characters, which can be A-Z, 1-9, \$, #, and @. The first character cannot be a number.) If your installation uses Personal Services/TSO/E for office and mail services, supply information in the following fields:

If you use...

Then supply...

DISOSS network

DISOSS USER ID and DISOSS SYSTEM fields

NJE network

SYSTEM NODE and DIRECTORY ID fields

Follow your installation's conventions regarding the content and format of each field.

To save the addition

Press the Enter key on the second panel.

To cancel the addition

Press the END PF key on either panel.

Maintaining Groups in the Master Names Directory

1. On the main menu panel, select the option for maintaining the names directory.
2. On the Names Directory Menu panel, select the GROUPS option.
3. Do one of the following:
 - On the Group Identification panel, supply enough information about the group to uniquely identify the group.
 - Request a list.

To see a list of all the groups, leave the asterisk (*) or blanks in each field. (Blank fields default to an asterisk.) To see only groups meeting certain

conditions, supply information to restrict the list. For example, for a list of groups beginning with "Dept", you would supply the following on the Group Identification panel:

```
ICQAAE20          NAMES - GROUP IDENTIFICATION
COMMAND ===>

To find, modify, or delete a group, type the information where requested.
All information is optional. To request a list, "*" may be used.
To add a group, type A on the COMMAND line.

GROUP NAME      ===> dept*_
DESCRIPTION     ===> * _____
```

If a list is too long to fit on one panel, press the UP and DOWN PF keys to go up and down the list.

4. To view, modify, or delete an existing group, type V, M, or D next to it. If the group you are looking for does not exist, you can add it by typing A on the COMMAND line and pressing the Enter key.

Viewing a Group

To view

Type a V in the field to the left of the group and press the Enter key. All the entries in the group are displayed in a list. Some of the entries in the group might be groups. The type of entry (name or group) is listed under the heading TYPE.

To view an entry in the group

Type a V in the field to the left of the entry and press the Enter key.

To end viewing

Press the END PF key.

Modifying a Group

To modify

Type an M in the field to the left of the group and press the Enter key. You see a panel listing the group name, the group description, and the entries in the group.

Restrictions on modifying

You cannot modify a name entry from the GROUPS option. To modify a name in a group, choose the NAMES option and modify the names entry.

To change the group name or description

Type over the information.

To view an entry in the group

Type V next to it and press the Enter key.

To delete an entry from the group

Type D next to it and press the Enter key.

To add entries to the group

Type A on the COMMAND line and press the Enter key. Supply information on the next panel that appears.

Entries can be names or other groups, and all entries must be in the names directory. Before you can add to the group a name or group not in the names

Maintaining Groups in Master Names Directory

directory, you must define the entry to the names directory as described in “Adding a Name” on page 38 for a name or in “Adding a Group” for a group.

Because the entries are in the names directory, you can use an asterisk (*) in one or more fields to request a list of entries and select from the list. To see only entries that satisfy certain conditions, supply information to restrict the list. For example, to see entries with the last name of “Smith” and a first name beginning with “D”, type `smith` and `d*`.

To save additions to the group

Press the END PF key.

To cancel the additions

Type CANCEL on the COMMAND line and press the Enter key.

To save modifications

Press the END PF key.

To cancel modifications

Type CANCEL on the COMMAND line and press the Enter key.

Deleting a Group

When you delete a group, the group is deleted from all other master directory groups that include it. You do not need to delete the group from groups containing it. (To delete entries from a group without deleting the entire group, see “Modifying a Group” on page 39.)

To delete

Type a D in the field to the left of the group and press the Enter key. After you press the Enter key you see the Delete Confirmation panel.

To confirm deletion

Press the Enter key.

To cancel deletion

Press the END PF key.

Adding a Group

To add

Type A on the COMMAND line of the Group Identification panel or the List of Groups panel and press the Enter key.

To supply entries for the group

Type the information that defines the group you want to add. The group name is required. The group name can be up to seven characters long, and must not duplicate either another group name or a directory ID. (The group name can use characters A-Z, 1-9, \$, #, and @. The first character cannot be a number.)

Entries can be names or other groups, and all entries must be in the names directory. Before you can add to the group a name or group not in the names directory, you must add the name or group to the names directory. See “Adding a Name” on page 38 for information on adding a name.

Because the entries are in the names directory, you can use an asterisk (*) in one or more fields to request a list of entries and select from the list. To see only entries

that satisfy certain conditions, supply information to restrict the list. For example, to see entries with the last name of "Smith" and a first name beginning with "D", type smith and d*.

To save the addition

Press the END PF key.

To cancel the addition

Type CANCEL on the COMMAND line and press the Enter key.

Processing User Requests to Update the Master Directory

Users can request changes to the master directory. You, as administrator, must view these change requests and decide whether to accept or reject them.

To process a request

1. On the Names Directory Menu panel, select the REQUESTS option and press the Enter key.
2. To view a request before processing it, type V in the field to the left of the request and press the Enter key. If you view a delete request, you see an entry from the names directory that a user wants to delete. If you view an add or modify request, you see information for the entry with the requested additions or changes in the appropriate fields.

To compare information for an add or modify request with what is currently in the master directory, use the SPLIT PF key and view the entry in the master directory through the user services. To do this:

- a. Move the cursor to the top of the screen.
 - b. Press the SPLIT PF key. You see the main Information Center Facility Administrator selection panel.
 - c. Select the option for using the user services and press the Enter key.
 - d. Select the option for using the names directory.
 - e. If the request is a name, select the NAMES option. If the request is a group, select the GROUPS option. Press the Enter key.
 - f. Find the name or group you want to view. Type V next to the name or group and press the Enter key.
 - g. Swap back and forth between the master directory entry and the request using the SWAP PF key.
 - h. When you are finished comparing the two entries, swap to the master directory entry and keep pressing the END PF key until you are back to the request in an unsplit screen.
3. After you finish viewing the request, press the Enter key to return to the request list. Then do one of the following:
 - Accept the request by typing A next to the entry and pressing the Enter key.
 - Reject the request by typing R next to the entry and pressing the Enter key.

When you are finished processing a request, a message appears telling you whether the master directory was updated with the request. The originator of the request also receives a message.

Note: Requests must be processed one at a time. You cannot type a letter (V, A, or R) next to more than one request.

Maintaining the TRANSMIT/RECEIVE Names File

The TSO/E TRANSMIT and RECEIVE commands use a names file (NAMES.TEXT) to send messages and data. This NAMES.TEXT file uses information from the master names directory, but is not the same as the master names directory. Names from the master names directory are defined in the NAMES.TEXT file, but groups are not defined.

If you change names in the master names directory, also update the NAMES.TEXT file with the changes.

To update NAMES.TEXT

Select the NAMESTEXT option on the Names Directory Menu panel before you exit the names directory option. A message appears telling you whether the NAMES.TEXT file was updated.

For more information about using the TRANSMIT/RECEIVE commands, see *z/OS TSO/E User's Guide*.

Chapter 6. Maintaining Courses

Overview of Maintaining Courses

Education services give users access to three types of courses:

1. **IIPS courses.** IIPS courses are created using the Interactive Instructional Authoring System (IIAS) and presented by the Interactive Instructional Presentation System (IIPS).
2. **Computer courses.** Users take computer courses at a terminal. These courses do not use the IIPS and IIAS program products. Instead, they use other program products your installation provides.
3. **Classroom courses.** Users take these courses in a classroom, not at their terminals.

Using education services, users can:

- View a list of courses, including course names, conditions and types
- Read online course descriptions called abstracts
- Request registration in available courses
- Take, audit or produce (write) courses
- Print course abstracts

As administrator for education services, you

- Maintain the list of courses and course abstracts by:
 - Maintaining course names
 - Changing course conditions
 - Specifying the maximum number of students to be registered in a classroom or IIPS course
 - Maintaining course abstracts
 - Specifying the TSO/E user ID for IIPS course authors
 - Specifying an IIPS course alias
 - Specifying computer course invocation parameters
- Access the course list and course abstracts to:
 - Add a course
 - Modify a course
 - Delete a course
 - Print a course abstract
- Process registration requests from users
- Maintain course registration lists, so users know in which courses they are registered
- Modify the administration defaults the Information Center Facility uses in maintaining education services

Note: As the administrator for education services, you can get the IIPS administrator ID from the system programmer who installed the product. You can then maintain IIPS courses and register and delete students for IIPS courses through the Information Center Facility.

Overview of Maintaining Courses

Before You Begin

Before you begin maintaining education services, read the online tutorial. The tutorial describes how to perform the tasks for maintaining the names directory. To read the tutorial, select:

1. The option for maintaining education services on the main menu panel for administrators.
2. The TUTORIAL option on the Education Services Menu panel.

For detailed information about using a particular panel, press the HELP PF key while you are on that panel.

Maintaining Course Names, Conditions, and Abstracts

Using the ABSTRACT option of education services, you can maintain the names of courses, their conditions, and abstracts of the courses.

Course Name

The course name is the title of the course. The names of IIPS and classroom courses are closely connected to the registration lists for the courses. When you modify the name of one of these courses, you also modify the name of the course in the registration list.

Because of this connection, use caution when changing a course name. Students registered for the course see REGISTERED next to the new course name. Seeing this, they might think they have been registered in a new course and deleted from the old one.

Course Condition

Every course in the course list has a condition associated with it. The condition indicates whether the course is installed and whether users can register for, take, or audit the course. The following table shows valid course conditions, the types of courses to which they apply, and the circumstances under which you would assign each condition.

Table 2. Valid Course Conditions and Their Meanings

Course Condition	Applies To:	Meaning
AVAILABLE	Computer IIPS	The course has been installed successfully. For computer courses, use only after installing and testing the course. For IIPS courses, use only after an IIPS administrator has installed the course and given it a guest ID. (The guest ID allows users to audit the course.)
UNAVAILABLE	Any course	The course is temporarily unavailable. Use only to prevent students temporarily from taking, auditing, or registering for a valid, active course (for example, to allow the author to update the course).
VIEW ABSTRACT	Any course	The course is not installed or available for registration, but users can view an abstract.

Table 2. Valid Course Conditions and Their Meanings (continued)

Course Condition	Applies To:	Meaning
REGISTER ONLY	IIPS Classroom	Students can register to take the course, but cannot audit it.
NEW	Any course	The course is under development. By default, only administrators and the author can see the course name when viewing the list of courses.

The list of courses that users see is usually only part of the list you see as administrator. Those courses with the condition NEW are, by default, not visible to users. Your installation can change this default as described in “Modifying Administration Defaults” on page 53.

Course Abstract

A course abstract is a brief description of a course. Some abstracts list course objectives and materials required for the course.

IBM® supplies course abstracts with the Information Center Facility. Initially, these abstracts have the condition NEW. To allow users to see them, you must change the course condition.

Displaying the Course List

You maintain course names, conditions, and abstracts from the course list.

To display the course list

1. On the main menu panel, select the option for maintaining education services. You see the menu panel for education services.
2. On the Education Services Menu panel, select the ABSTRACT option. You see the course list.

Viewing a Course Abstract

To view

Type a V in the field to the left of the course name and press the Enter key. You see the panel for viewing the course abstract. If text does not fit on one panel, use the UP and DOWN PF keys to read the entire abstract.

To end viewing

Press the END PF key on the panel for viewing the course abstract.

Printing a Course Abstract

You can print a course abstract from the Course Abstracts panel and from the View a Course Abstract panel. The printer that you select must be defined to the Information Center Facility or the print request cannot be completed. See Chapter 10, “Setting System Defaults: Printer Support,” on page 77, for more information about defining printers to the Information Center Facility.

To print a course abstract

1. To print a course abstract from the Course Abstracts panel, type P to the left of the abstract. To print a course abstract from the View a Course Abstract panel, type P on the COMMAND line. Press the Enter key.

Maintaining Names, Conditions, Abstracts

The Printer Specification panel appears. Figure 8 shows the Printer Specification panel.

```
ICQCNE30      Information Center Facility – Printer Specification
COMMAND ==>>

Type the information where requested and press Enter.

Printer Location ==> * _____ Printer location or *
Print Format      ==> * _____ Document format or *
Printer Type      ==> * _____ Printer type or *

Number of copies ==> 1                      Specify 1 to 255 copies
```

Figure 8. Printer Specification Panel

2. You can either specify a particular printer, or obtain a printer selection list. Specify a particular printer on the printer selection entry lines, or type a partial value with an asterisk (*) suffix, or an asterisk (*) by itself on any of the three data entry fields to obtain a list of available printers.
A previously-selected printer, if any, remains as the default until you change the printer identification.
3. Use the NUMBER OF COPIES field to request a number of copies of the course abstract. The default for the number of copies is 1.

Adding a Course

When you add a course, you can supply the following information:

- A unique course name (required).
- The maximum number of spaces for the course (does not apply to computer courses). This number is informational only. If you supply a maximum number of spaces, you can still register more than the maximum number of students. However, the Information Center Facility notifies you that the maximum number has been reached every time you try to register another student.
IIPS courses have a registration limit, so you must not specify a maximum larger than the registration limit.
- For IIPS courses only:
 - The IIPS course alias. The alias must match the course name the IIPS administrator used when adding the course to your system. You must supply the IIPS course alias before supplying the author's TSO/E ID or changing the course condition to AVAILABLE, UNAVAILABLE, or REGISTER ONLY.

Note: The Information Center Facility does not check to see if the alias matches the course name the IIPS administrator used. However, if the two names do not match, you cannot register students in the course. In addition, users who try to audit, take, or produce (write) the course, see a message that the course is not registered while in IIPS.
 - The TSO/E ID of the course's author. When you supply the author's ID, the user with that ID sees AUTHOR after the course name in the course list. This user can edit the course. Note that the author can see the course name in the course list even if the course condition is NEW.
- For computer courses only:
 - The name of the CLIST, TSO/E command, or program to be invoked. If the invocation requires any parameters, you must supply the values of the parameters also.

- Whether to test the invocation. If you decide to test the invocation and the invocation is successful, you enter the course just as a user would. If the invocation fails, results are unpredictable. The system might return diagnostic messages. Contact your system programmer to resolve any problems.

When you add a course, the Information Center Facility assigns the course the condition NEW. If courses with the condition NEW are not visible to users (the default), you must change the course condition for users to see it.

Do not try to create a new course by modifying an existing one. If you do, people registered in the existing course are transferred to the new course.

To add a course

1. Type an A on the COMMAND line of the panel displaying the list of courses, and press the Enter key. You see a menu panel allowing you to choose the type of course you want to add.
2. Select the option for the type of course you want to add, and press the Enter key. You see the panel for adding that type of course.
3. Supply the course name and any other information needed, and press the Enter key.

To cancel adding the course

Press the END PF key on the panel for adding the course.

To add the course abstract

Type the abstract on the panel for supplying the abstract. Press the END PF key when finished supplying the abstract.

To cancel adding a course abstract

Type CANCEL on the COMMAND line of the panel for supplying the abstract, and press the Enter key.

If the IIPS Courses Data Set is Full

If the current data set for IIPS courses is full, your system programmer must:

- Allocate a new data set according to specific naming conventions.
- Set a variable in panel ICQSIECB so that courses in the new data set, as well as those in the previous data sets, are displayed.

For specific information about naming the data set and setting the variable, see *z/OS TSO/E Customization*.

Modifying a Course

Do not try to create a new course by modifying an existing one. If you do, people registered in the existing course are transferred to the new course.

To modify

On the panel displaying the list of courses, type an M next to the course you want to modify and press the Enter key. You see the panel for modifying the course.

To change information for the course

Type over the information displayed for the course on the panel for modifying the course. If you want to change the abstract, leave the Y in the MODIFY ABSTRACT field. If you do not want to change the abstract, change the Y in the MODIFY ABSTRACT field to N. Press the Enter key. If you left the Y in the MODIFY ABSTRACT field, you see the panel for modifying the abstract.

Maintaining Names, Conditions, Abstracts

To cancel modifying the course

Press the END PF key on the panel for modifying the course.

To change the text of the abstract

Type over the existing text for the abstract.

To save changes to the abstract

Press the END PF key on the panel for modifying the abstract.

To cancel changing the abstract

Type CANCEL on the COMMAND line of the panel for modifying the abstract, and press the Enter key.

Deleting a Course

Deleting a course from the course list deletes all of the records the Information Center Facility keeps for the course. Specifically, it:

- Deletes the course name from the course list displayed to users and administrators
- Deletes the associated course registration list, which the Information Center Facility keeps to support the REGISTERED condition on the course list users see

Deleting a course does not, however, delete the associated IIPS or computer course from the system.

To delete

On the panel displaying the list of courses, type a D next to the course you want to delete, and press the Enter key. After you press the Enter key, you see the panel for deleting a course. This panel allows you to confirm that you want to delete the course. The panel also lets you choose to view the abstract before deleting the course.

To view the abstract before deleting

Leave the Y in the VIEW ABSTRACT BEFORE DELETING field. Press the Enter key. You see the panel for viewing the abstract.

To end viewing the abstract

Press the END PF key on the panel for viewing the abstract.

To delete the course

If the VIEW ABSTRACT BEFORE DELETING field is set to Y, change the Y to N and press the Enter key. If the field is already set to N, just press the Enter key.

To cancel deleting the course

Press the END PF key on the panel for deleting a course.

Processing Registration Requests

Users can request registration in IIPS or classroom courses. Periodically, you need to process these registration requests.

Displaying Student Registration Requests

To display requests

1. On the main menu panel, select the option for maintaining education services. You see the Education Services Menu panel.

2. On the Education Services Menu panel, select the REQUESTS option. You see a panel displaying registration requests.

Processing Requests for Registration in Classroom Courses

To accept

Type an R next to the registration request on the panel displaying registration requests, and press the Enter key.

To delete

Type a D next to the registration request on the panel displaying registration requests, and press the Enter key. The person requesting registration receives a message that registration was denied.

Processing Requests for Registration in IIPS Courses

When you accept a request for registration in an IIPS course, education services requests the following information:

- Your IIPS administrator's ID and password, if you have not already supplied them. If you do not know your ID and password, you can get them from the system programmer who installed IIPS.
- The IIPS student number. IIPS uses the student number for record keeping. Frequently, installations use an S followed by the student's TSO/E user ID. (For information on changing the default student number that appears on the screen, see "Modifying Administration Defaults" on page 53.)
- Whether the registration is to be marked permanent. To remove a permanent registration, an IIPS administrator must supply the student's student number on the IIPS REMOVE STUDENT command. If the registration is not permanent, you can remove the registration after a certain date, after the student completes the course, or after a certain length of time has elapsed since the student last accessed the course.
- The location number and area number. The location and area numbers are installation-dependent information that usually identifies the geographic location of the student. However, the numbers can represent any kind of division among students. Your installation defines valid location and area numbers using the IIPS LOC command. The system treats the location as a category under the area.
- The type of recording. This is a number from 0–15, and indicates the type of student responses to be recorded. The statistics from the recorded responses are intended for the author's use in course maintenance. For more information, see *IIPS/IIAS Administrator's Guide*.

The following table shows what types of answers are recorded for each number.

Processing Registration Requests

Type of Answers Recorded					
	None	Correct	Incorrect	Anticipated	Unanticipated
0	x				
1		x			
2			x		
3		x	x		
4				x	
5		x		x	
6			x	x	
7		x	x	x	
8					x
9		x			x
10			x		x
11		x	x		x
12				x	x
13		x		x	x
14			x	x	x
15		x	x	x	x

Before Processing Your First IIPS Registration Request

If the system fails at some points while processing an IIPS registration request, the request might be lost. You can see what processing did occur by browsing your ISPF log.

To have an ISPF log, your primary page specification for the log data set must be greater than zero. Make sure that the page specification is not zero. You can see the log data set parameters in your profile by selecting the ISPF PARMS option on the ISPF/PDF Primary Option Menu panel.

To accept

1. Type an R next to the registration request on the panel displaying registration requests, and press the Enter key.
2. If you have not yet entered your IIPS administrator's ID since logging on, you see a panel for entering your IIPS ID and password. Supply your ID and password, and press the Enter key.

If this is the first registration request, you might notice a delay. Subsequent requests will be faster.

You see a panel requesting the following information: (1) the IIPS student number, (2) the type of recording, (3) whether the registration is permanent, (4) the location number and area number.

Supply the requested information and press the Enter key.

To delete

Type a D next to the registration request on the panel displaying registration requests, and press the Enter key. The person requesting registration receives a message that registration was denied.

If you accept a request for registration, and the registration is successful, the registration list for the course is updated. When the student displays the course list, the student will see REGISTERED next to the course name.

If the registration request fails, you usually see output from the IISBATCH program. You must use the diagnostic information to determine why the request failed and to correct the problem.

If the system fails at certain points while processing the request, the request might be lost. To determine what processing occurred, you can browse the ISPF log. (Select the DIALOG TEST option on the ISPF/PDF Primary Option Menu, and the LOG option on the panel you see after that.) The system records in the ISPF log the critical steps of the registration process.

If you have some experience using TSO/E and IIPS, or you are using Session Manager, you might find additional information from WTP (write-to-programmer) messages helpful. To see these messages, type the following TSO/E command on the COMMAND or OPTION line of any Information Center Facility panel:
PROFILE WTPMSG.

If an IIPS Registration Request Fails

If your request fails, your system programmer might need the following information:

- The education services issue an IIPS REGISTER STUDENT command using information supplied by the administrator. If education services does not issue the command correctly, the problem might be the BCONFIG member of the IIPS.OS.CTLCARD data set. (Your installation might use a qualifier other than IIPS in the data set name.)
- The Information Center Facility uses the IISBATCH program to process registration requests for IIPS courses. BCONFIG contains control statements for IISBATCH. BCONFIG must contain the statement DISK nn =YES, where nn corresponds to the number of the data set in which the course resides. The DISK nn statement identifies the course data set to IISBATCH. If the statement is omitted, registration fails. Therefore, make sure that BCONFIG contains a DISK nn =YES statement for each data set that might contain a course in which students can request registration using the Information Center Facility.

Updating Course Registration Lists

Every IIPS or classroom course in the Information Center Facility has a registration list. Users on the registration list for a course see the word REGISTERED instead of the course condition on the panel for selecting courses.

You must update these registration lists directly to add a student to a list without a registration request, or to delete a student from a list. You might also need to update registration lists for IIPS courses directly.

IIPS has its own set of registration lists for IIPS courses. If your IIPS administrator uses IIPS commands to update these registration lists directly, the registration lists the Information Center Facility maintains will not reflect the updates. You must update the registration lists in the Information Center Facility to keep them accurate.

Updating Course Registration Lists

It is important that you update the Information Center Facility's version of the course registration list at the right time:

- Add a student to the registration list *after* the IIPS administrator registers the student.
- Delete a student from the registration list *before* the IIPS administrator cancels the student's registration.

Timing is important to prevent a user from trying to enter a course when the user is not registered in the course.

Displaying the Course Registration List

To display a registration list

1. On the main menu panel, select the option for maintaining education services. You see the Education Services Menu panel.
2. On the Education Services Menu panel, select the LISTS option. You see a list of course names.
3. Type S next to a course. You see the registration list for that course.

Adding a Student to the Registration List

To add

1. Type an A on the COMMAND line of the panel showing the registration list, and press the Enter key.
2. Type the person's user ID in the USERID field, and press the Enter key. If the student's user ID is in the names directory, the Information Center Facility adds the name to the registration list.

If the user ID is not in the names directory, you see a message to that effect. The student's user ID must be added to the names directory before you can add the student to the registration list. You must reenter the LISTS option before trying to add the student again to ensure that the Information Center Facility uses the updated version of the names directory.

To save the addition

Press the END PF key on the panel showing the registration list.

To cancel the addition

Type CANCEL on the COMMAND line of the panel showing the registration list, and press the Enter key.

Deleting a Student from the Registration List

To delete

Type a D next to the name of the student you want to delete, and press the Enter key. You see the panel for confirming the deletion.

To confirm the deletion

Press the Enter key on the panel for confirming the deletion.

To cancel the deletion

Press the END PF key on the panel for confirming the deletion.

Invoking IIPS as an IIPS Administrator

You can sign on to the IIPS system as an administrator using Information Center Facility panels.

To sign on

1. On the main menu panel, select the option for maintaining education services. You see the Education Services Menu panel.
2. On the Education Services Menu panel, select the IIPS option. You see a panel for supplying the IIPS administrator ID.
3. Type the ID and press the Enter key. You are signed on to IIPS and can issue IIPS commands. When you sign off IIPS, the system returns you to the Education Services Menu panel.

For more information about IIPS and the role of the IIPS administrator, see:

- *IIPS IAS Administrator's Guide*
- *IIPS IAS General Information Manual*
- *IIPS IAS Operator's Guide*.

Modifying Administration Defaults

The administration defaults you can change are the:

- IIPS student and author IDs
- High-level qualifier for IIPS data sets
- Course conditions suppressed from the course list that *users* see

IIPS Student and Author IDs

For the IIPS student and author IDs, the IBM-supplied default is an S (for student) or an A (for author) followed by the TSO/E user ID. This default appears in fields prompting you for an IIPS student or author number. To use this default, keep the IIPS = USERID field on the defaults panel set to Y. If you set IIPS = USERID to N, fields prompting you for a student or author number will contain an S or an A followed by blanks.

High-Level Qualifier for IIPS Data Sets

All IIPS data sets have the same high-level qualifier. The IBM-supplied default for this qualifier is IIPS. If your installation uses a different high-level qualifier, change the default in the IIPS DATA SET QUALIFIER field, or you will not be able to process registration requests.

Course Conditions Suppressed from the User List

By default, courses with the course condition NEW do not appear on the list of courses that users see. To allow users to see all courses with a particular condition, type a Y after the course condition on the defaults panel. To suppress from the user list all courses with a particular condition, type an N after the course condition.

Modifying the Defaults

To modify the defaults

1. On the main menu panel, select the option for maintaining education services. You see the Education Services Menu panel.
2. On the Education Services Menu panel, select the DEFAULTS option. You see a panel showing the current administrator defaults.

Modifying Administration Defaults

3. Type over the defaults you want to change.

To keep the changed defaults

Press the Enter key on the panel showing the defaults.

To cancel changing the defaults

Press the END PF key on the panel showing the defaults.

Chapter 7. Enrolling Users Through the Information Center Facility

Overview of Enrolling Users Through the Information Center Facility

The Information Center Facility's user enrollment service is a simple way to add users to TSO/E and identify them to the Information Center Facility

If a person already has a TSO/E user ID, you can still follow the enrollment process explained later in the chapter. The enrollment process takes you through the necessary steps to achieve the following results:

1. **Create or update an Information Center Facility names directory entry** for the person.
2. **Assign a user type to define the user to various components of the system**, such as TSO/E, RACF, and the VSAM master catalog.
3. **Create or update the Information Center Facility/ISPF user profile.** The Information Center Facility creates the user's profile by copying the system default ISPF profile. The user profile controls communication between the user and the system by setting:
 - Terminal characteristics, such as the type of terminal, the number of PF keys, and the screen format.
 - Log and list parameters that determine how information in the log and list data sets are processed (such as printed or filed) when a user exits from the Information Center Facility.
 - Program function (PF) keys. These keys can be set to issue one or more commands or subcommands such as END, PRINT, or SPLIT screen.

At the end of this chapter is an enrollment worksheet. You can make a copy of the worksheet on which to write specific information necessary to enroll a person.

Your installation can use security labels if RACF is installed. To define security labels for users, you must use RACF commands. The Information Center Facility does not support security labels. See *z/OS Security Server RACF Security Administrator's Guide* for information about defining security labels for users.

Two other Information Center Facility services are related to enrollment:

- **Maintaining user type definitions** (the USERTYPE option). A user type defines how a person uses TSO/E and the Information Center Facility, for example, as an administrator or as a user. This service allows you to add, modify, delete, or view user type definitions. User type definitions specify information used in enrollment. When enrolling a person, instead of specifying the information directly, you assign the person a user type. To read more about user types, see Chapter 8, "Maintaining User Type Definitions," on page 63.
- **Setting the system default ISPF profile** (the ISPFDEF option, which is available from the SYSDEF option). Using the ISPFDEF option, you can change the model profile the system copies during enrollment. For more information, see Chapter 9, "Setting System Defaults: ISPF Profile," on page 75.

Overview of Enrolling Users Through the Information Center Facility

Before You Begin

Before you begin the enrollment process, read the online tutorial. The tutorial describes how to perform the tasks necessary in enrolling people in the Information Center Facility. To read the tutorial, select:

1. The ENROLL option on the main menu panel for administrators
2. The TUTORIAL option on the Enroll Menu panel.

For detailed information about using a particular panel, press the HELP PF key while you are on that panel.

Procedure for Enrolling People

To enroll a person through the Information Center Facility

1. Select the ENROLL option on the first administrator selection panel, and press the Enter key.

Type information to see if the person's name is already in the names directory. (If you know the person is not in the names directory, type E on the COMMAND line.)

```
ICQAE10          ENROLL - USER IDENTIFICATION
COMMAND ==>>

To take the tutorial for enrollment, type T on the COMMAND line and press
Enter; to find, modify, or enroll a user, type the information where
requested. All information is optional. To request a list, "*" may be used.
To enroll a user not in the Names directory, type E on the COMMAND line.

  LAST NAME      ==> smith_____
  FIRST OR NICKNAME ==> *_____
  USER ID       ==> *_____

Additional search information
  DEPARTMENT NUMBER ==> *_____
  DEPARTMENT NAME   ==> *_____
  JOB TITLE         ==> *_____

  DIRECTORY ID     ==> *_____ Unique id for names directory
  SYSTEM NODE      ==> *_____ System ID used for electronic mail
  USER TYPE       ==> *_____
                                     User type for Information Center Facility
```

Figure 9. Enroll – User Identification

2. If the information you typed matches entries in the names directory, you see a list of the entries that match.

```

ICQAE11          ENROLL - LIST OF USERS          SCROLL ==> PAGE
COMMAND ==> E

To enroll, E , view, V , or modify, M , a user, type the letter to the left
of the selected user.
To enroll a user not in the Names directory, type E on the COMMAND line.

  LAST NAME      FIRST NAME      USER ID  TYPE
-   Smith        Glenn          GWS2
-   Smith        Manny
-   Smith        Mario          MAS
  SEC
-   Smith        Roy            SMITTY
  MGR
  
```

Figure 10. Enroll – List of Users

- If one of the entries matches the name you want to enroll, type E to the left of it and press the Enter key. If essential information is missing from the names directory, a message appears. To modify the names directory entry and add the essential information, type M next to the name.
 - If no entry matches the name, a message appears. Type E on the COMMAND line and press the Enter key.
3. Type the appropriate names directory information for the new user. To ensure that all directory entries are uniform, follow your installation's conventions for content and format.

```

ICQCAE12          ENROLL - ADD OR MODIFY A USER          Page 1 of 2
COMMAND ==>

Type the information where requested, or change the information shown by
typing over it. Only LAST NAME is required. To continue to page 2, press ENTER.

LAST NAME          ==> Smith_____
FIRST NAME         ==> Sharon_____
NICKNAME           ==> Sheri_____
MIDDLE NAME        ==> L._____
LAST NAME SUFFIX   ==> _____ For example: Jr., III, Ph.D., etc.
TITLE              ==> Ms.____ For example: Mr., Mrs., Ms., Dr., etc.

INTERNAL ADDRESS   ==> 920/S10 _____
EXTERNAL ADDRESS   ==> 220 Old Mill Rd._____
                   Weston, N.Y._____
                   _____
                   _____
  
```

Figure 11. Enroll – Add or Modify a User

4. Press the Enter key to see the second names directory panel. Type additional information or change the information displayed.

Procedure for Enrolling People

```
ICQAEE13                      ENROLL - ADD OR MODIFY A USER                      Page 2 of 2
COMMAND ==>>>

Type the information where requested, or change the information shown by
typing over it. Only DIRECTORY ID, USER ID, and USER TYPE are required.
To go back to Page 1, type BACK on the COMMAND line.

NAME..... Smith, Sharon
TELEPHONE    ==>> 6321_

JOB TITLE    ==>> Programmer_
DEPARTMENT NAME ==>> Product Development_
DEPARTMENT NUMBER ==>> D90_

DIRECTORY ID ==>> SHAR_ Unique identifier for names directory
USER ID      ==>> SLS4_
SYSTEM NODE  ==>> PLPSC_ System ID used for electronic mail
DISOSS USER ID ==>> _ User ID used for DISOSS
DISOSS SYSTEM ==>> _ System ID used for DISOSS
USER TYPE    ==>> User_
                                     Information Center Facility user type, or
                                     "*" for list of user types
```

Figure 12. Enroll – Add or Modify a User

If your installation uses Personal Services/TSO for office and mail services with a DISOSS network, fill in the DISOSS USER ID and DISOSS SYSTEM fields for distribution of notes and documents. If your installation uses Personal Services/TSO with a NJE network, it uses the SYSTEM NODE and DIRECTORY ID fields for the distribution of notes and documents. In either case, the DIRECTORY ID field is required.

5. When both enrollment panels are completed, press the Enter key. You then see a panel that uses the user definition to identify the person to the Information Center Facility, RACF, and the master catalog. All of the information shown is required except the RACF name and, in some cases, the master catalog password.

Note: Figure 13 on page 59 shows panel ICQAEE41. If you are not using both RACF and UADS, panel ICQAEE40 is displayed instead of ICQAEE41. The only difference is that panel ICQAEE40 does not contain the UPDATE RACF and UPDATE UADS fields.

```

ICQAE41          ENROLL - INFORMATION CENTER IDENTIFICATION
COMMAND ==>>
The entry was added to the master directory.  ICQCA121
Type the information where requested, or change the information shown by typing
over it.

USERID ..... SLS4
USER TYPE ..... USER

NEW TSO ID      ==> Y          (Y/N)
RACF NAME       ==>
OPERATOR ID CARD ==> N          (Y/N)
PASSWORD        ==> ICQICF
ACCOUNT NUMBER  ==> D90ICF
MASTER CATALOG
PASSWORD        ==>

CHANGE ISPF DEFAULTS
NEW USER        ==> Y          (Y/N)
ADMINISTRATOR   ==> N          (Y/N)
UPDATE RACF     ==> Y (Y/N)  Enroll user in the RACF data base
UPDATE UADS     ==> N (Y/N)  Enroll user in the UADS data set
    
```

Figure 13. Enroll – Information Center Identification

The following list describes the information you are asked to enter.

NEW TSO ID

Type Y or N (yes or no) to indicate whether the person needs a TSO/E ID (Y) or already has one (N).

RACF NAME

Type the name that RACF is to associate with the person's TSO/E user ID. The RACF name is optional. If you supply none, RACF uses a default (20 # signs).

OPERATOR ID CARD

- Type Y or N to indicate whether the person you are enrolling will be required to insert an operator ID card when logging onto the system. (Some terminals have a card reader attachment for reading operator ID cards during LOGON processing. Operator ID cards are a security feature.)

The value in this field must match the value in the OPERATOR ID CARD field in the user type definition you select (the OPERATOR ID CARD field on any panel that displays the RACF ADDUSER parameters for the user type).

If you typed Y in this field, after you press the Enter key, a message appears that tells you to insert the operator ID card to continue. Inserting the card associates the card with the user.

PASSWORD

Type the password the person must enter when accessing TSO/E. It need not be unique.

ACCOUNT NUMBER

- Type the number to which the person's computer time is to be charged. If the person has an existing TSO/E user ID, you must enter a different account number from the one specified previously.

MASTER CATALOG

PASSWORD

Type the password, if any, required to access the master catalog. If your installation's master catalog is password-protected and the user type you

Procedure for Enrolling People

assign specifies parameters for the DEFINE ALIAS command, you must enter the master catalog password. (The DEFINE ALIAS command updates the master catalog.)

CHANGE ISPF DEFAULTS

NEW USER

- If the person that you are enrolling has a new TSO/E user ID, you can change that user's ISPF defaults. Type Y or N (yes or no) to indicate whether you want to change any of the options in the new user's default ISPF profile. The system initializes the user's profile by copying the system default ISPF profile.

The system default ISPF profile is either:

- The default profile supplied by ISPF/PDF
- The Information Center Facility customized default profile if you used the SYSDEF option to modify the ISPF system defaults

See "Setting ISPF Defaults" for more information about changing a user's ISPF defaults.

Note: To modify the system default ISPF profile itself, select the SYSDEF option on the main menu panel for administrators and then select the ISPFDEF option.

CHANGE ISPF DEFAULTS

ADMINISTRATOR

You, as the administrator, have the option of editing your own ISPF defaults. Type Y or N (yes or no) to indicate whether you want to change any of the options in your default ISPF profile.

UPDATE RACF

- This field is displayed only if your installation provides a choice of where to store user information. Type Y or N (yes or no) to indicate whether you want to store a TSO/E segment for a user in the RACF data base with the user profile.

For more information about where to define users, see Chapter 2, "Defining Users to TSO/E," on page 11.

UPDATE UADS

- This field is displayed only if your installation provides a choice of where to store user information. Type Y or N (yes or no) to indicate whether you want to store TSO/E user information in the SYS1.UADS data set and a user profile in the RACF data base.

For more information about where to define users, see Chapter 2, "Defining Users to TSO/E," on page 11.

Setting ISPF Defaults

When you enroll a user, the system uses the system default ISPF profile to create a profile for the user. During the enroll process, you can change the ISPF default profile for the user being enrolled.

To change an ISPF default profile

1. Type Y in the CHANGE ISPF DEFAULTS for the USER and/or ADMINISTRATOR field on the Enroll Identification panel to access the ISPF parameter options panel. The ISPF parameter options panel is the ISPF/PDF panel ISPOPTA.

The ISPF parameter options panel contains categories of defaults. Choose the categories of defaults you want to change.

Notes for changing a USER's default profile:

- a. You cannot access the ISPF parameters options panel if you are in split-screen mode. If you type a Y to change a user's ISPF defaults, and your screen is split, you will receive an error message.
 - b. You cannot split the screen when you are using the ISPF/PDF defaults dialog to change a user's ISPF defaults.
 - c. Do not use the KEYS command to update your own keys when you are customizing a user's ISPF profile. If you are in the process of changing a user's ISPF profile, modifications to the key settings using the KEYS command are made to the user's profile. You can use the KEYS command to update your keys at this time.
2. Type over the default information you want to change. Press the END PF key and you are returned to the default selection panel. You can then select another set of defaults to change.
 3. After making all your updates, press the END PF key to save the changes.

Although you might have made changes on several panels, the system saves the changes only after you press the END PF key while the ISPF parameter options panel is displayed. You can cancel all of your changes by typing CANCEL after the OPTION arrow on that panel.

For a detailed explanation of setting ISPF defaults, see *z/OS ISPF User's Guide Vol I*.

Resynchronizing ISPF Defaults

Whenever a new release of ISPF/PDF is installed, you must reset the ISPF default profile tables. If you have customized the Information Center Facility system defaults, you should use the SYSDEF option to re-customize the default profile for enrolled users.

To reset ISPF default profile tables

Use the ISPF/PDF Library utility (usually option 3.1 on the ISPF/PDF main menu panel) to delete the members ISPSPROF and ICQZPROF. The default data set that these tables reside in is ICQ.ICQTLIB. This data set is defined in the ICQISPFDEF function.

ENROLL Worksheet

Information you need to enroll a new user is below. Required information is preceded by an R.

Information	Specific Value	Notes
R Last name		
First name		
Nickname		
First name		
Middle name		
Last name suffix		
Title		

ENROLL Worksheet

Information	Specific Value	Notes
Internal Address		
External Address		
Telephone		
Job Title		
Department name		
Department number		
R Directory ID		
R TSO/E User ID		
System node		
R User type		
RACF name		
R Is it a new TSO/E user ID?		
R Does the user need an operator ID card?		
R Logon password		
R Account number that pays for computer time		
Master catalog password		
R Do you want to change the ISPF defaults?		
If given a choice, enroll in RACF?		
If given a choice, enroll in UADS?		
R jobname		
R account number		
R user's name		
class		
msgclass		
parameters		

Cancelling User Enrollment

The Information Center Facility provides no panels for cancelling user enrollment. To delete a user's access to TSO/E, use the DELETE subcommand of ACCOUNT or, if your installation has RACF, the RACF ALTUSER NOTSO command. You can then remove the appropriate entry from the Information Center Facility names directory.

For information about the DELETE subcommand of ACCOUNT, see "Deleting Information from a User Definition" on page 25. For information about RACF commands, see *z/OS Security Server RACF Command Language Reference*.

Chapter 8. Maintaining User Type Definitions

Overview of Maintaining User Type Definitions

A user type defines a class of users, such as administrators, ordinary users, operators, and so on. When enrolling a user through the Information Center Facility ENROLL option, an administrator specifies a user type. Associated with each user type is the following information the system needs to define the user to the system and define the type of access the user has to various parts of the system.

USERID Information

When you use Information Center Facility panels to define a user to TSO/E, you supply user ID information that automatically becomes the parameters for the TSO/E ACCOUNT command and/or RACF commands, depending on how your installation is set up. If your installation uses the ACCOUNT command, the user ID information is stored in the user attributes data set (UADS) named SYS1.UADS. If your installation uses RACF commands, the user ID information is stored in the RACF data base. For more information about the ways to define users to TSO/E, see Chapter 2, “Defining Users to TSO/E,” on page 11.

RACF Security Information

RACF is an optional security server that protects system resources. You can supply information on Information Center Facility panels to define a user to an existing RACF group. A RACF group is a collection of RACF users who have the same access requirements to protected resources. A RACF administrator gives the appropriate access authority to each group.

VSAM Master Catalog Information

The master catalog keeps track of data sets in the system. You can use Information Center Facility panels to supply information for the VSAM DEFINE ALIAS command that puts a user catalog alias for the user's TSO/E ID into the master catalog. This action can improve performance by decreasing the time required to locate the user's data sets.

One of your jobs as an administrator is to maintain a set of user type definitions. The Information Center Facility supplies two pre-defined user types: USER and ADMINISTRATOR. If they are not suitable for all users at your installation, you can add new user types. You can also modify current user type definitions and delete those that are no longer needed. To aid in choosing and maintaining user types, you can display either a list of the currently defined user types, which includes a brief description of each, or a particular user type definition (that is, the information it specifies). For descriptions of the information each user type can include, see:

- “TSO/E User ID Information” on page 65
- “TSO/E Authorization Information” on page 67
- “RACF Security Information” on page 68
- “Optional RACF Information” on page 70
- “VSAM DEFINE ALIAS Parameters” on page 70

Overview of Maintaining User Type Definitions

Before You Begin

Before you begin maintaining user type definitions read the online tutorial. The tutorial describes how to perform the tasks for maintaining user type definitions. To read the tutorial, select:

1. The USERTYPE option on the main menu panel for administrators
2. The TUTORIAL option on the User Type Definitions menu panel.

For detailed information about using a particular panel, press the HELP PF key while you are on that panel.

Accessing Currently Defined User Types

You can display a list of all user types currently defined, a subset of that list, or the parameters in a specific user type definition. The following steps describe how to display this information using the Usertype panels. You can also display a list of user types while using the enrollment service.

1. Select the USERTYPE option on the first administrator selection panel. You then see:

```
ICQADE00      INFORMATION CENTER FACILITY - DEFINE USER TYPES
COMMAND =====>

To take the tutorial for defining user types, type T on the COMMAND line and
press ENTER; to begin using DEFINE USER TYPES, type the information where
requested or change the information shown by typing over it:

ACTION          =====> _      Add (A), Delete (D), Modify (M),
                                   View (V)

USER TYPE        =====> _____
                                   For Add specify the full name; otherwise
                                   part of the name with * suffix is permitted

USER DESCRIPTION =====> _____
                                   Only used for Add
```

Figure 14. Information Center Facility – Define User Types

2. Type V or leave a blank in the ACTION field.
3. In the USER TYPE field, identify the user type or types you want to see.
To display all that are currently defined, type an asterisk * or leave a blank in the field. After pressing the Enter key, you see all user types listed alphabetically. If the list continues on to another panel, use the UP and DOWN PF keys to see the entire list.

To see only the user types that start with a specific letter or letters, type those letters followed by an asterisk (*), for example:

```
USER TYPE =====> adm*
```

After you press the Enter key, the matching user types are displayed. You see a panel similar to the following one.

```

ICQADE02          USER TYPES - LIST OF USER TYPES          SCROLL ==>> PAGE
COMMAND ==>>>

To delete, D, Modify, M, or view, V, the commands that define the user
types, type the letter to the left of the selected user type and press ENTER.

      USER TYPE          DESCRIPTION
_ Administrator      Information Center Facility administrators
_ Admissions         Admissions advisors
  
```

Figure 15. User Types – List of User Types

To see the information in a specific user type definition either:

- Enter the complete name of the user type.
- Request a list of user types and type V in the Action field to the left of the one whose parameters you want to see.

In either case, after pressing the Enter key, you see:

```

ICQADM16          USER TYPES - SELECT USER INFORMATION
OPTION ==>>>

Select the desired option:

USER TYPE ..... user

  1  USERID   - TSO/E user ID information
  2  RACF     - RACF security information
  3  ALIAS    - VSAM define user catalog alias
  
```

Figure 16. User Types – Select User Information

4. Choose the information you want to see. After pressing the Enter key, you see one or more panels with the specific information used to define the user type. The following sections describe the information associated with each user type.

TSO/E User ID Information

User type definitions can specify the following information that becomes parameters for the TSO/E ACCOUNT command and/or RACF commands, depending on how your installation is set up. In addition, they can specify the authorization information listed in “TSO/E Authorization Information” on page 67. If the definition omits information, the system uses default values. The default values give the user authorization to use your installation's LOGON procedure.

Accessing Currently Defined User Types

```
ICQADE04          USER TYPES - VIEW TSO/E USER ID INFORMATION
COMMAND ==>>>

To view the next panel, press ENTER.

USER TYPE ..... User

LOGON PROCEDURE ..... ICQAPROC
MIN. REGION SIZE .... 0
MAX. REGION SIZE .... 0

HOLD CLASS .....
JOB CLASS .....
MESSAGE CLASS .....
SYSOUT CLASS .....

UNIT .....
DESTINATION ID .....
PERFORMANCE GROUP ...
USERDATA .....
```

Figure 17. User Types – View TSO/E User ID Information

LOGON PROCEDURE

The LOGON PROCEDURE field specifies the name of the procedure the system is to execute when the user logs on. The procedure defines the system resources available to the user. It might also specify which program the system is to invoke after LOGON processing is completed.

TSO/E supplies a sample logon procedure in ICQ.ICQSAMP(ICQAPROC). You can use a modified version of this procedure or one your installation has written.

MIN. REGION SIZE

The MIN. REGION SIZE field specifies the minimum amount of virtual storage the system can assign to the user's private area during LOGON processing. The number is in 1024-byte units.

If the field is blank or contains 0, the system assigns the minimum amount of storage. If the value in this field is greater than the value in the MAX. REGION SIZE field, the system uses the MAX. REGION SIZE value instead of the value in MIN. REGION SIZE.

MAX. REGION SIZE

The MAX.REGION SIZE field specifies the maximum amount of virtual storage the system can assign to the user's private area during LOGON processing. The number is in 1024-byte units. If this field is blank, the user profile specifies no upper limit on the region size.

HOLD CLASS

The HOLD CLASS field specifies the reserved output class the system assigns to jobs the user submits using SUBMIT commands that specify the HOLD parameter. The hold class determines on which hold queue the system places the job.

If this field is blank, the system assigns no default reserved output class. To have jobs held, either the user must specify HOLD=YES on the DD statement associated with the output data set, or the user's message class must be a held class.

JOB CLASS

The JOB CLASS field specifies the job class the system assigns to jobs if the user specifies none. The job class determines the priority at which jobs are executed. If this field is blank, the system assigns the job class.

MESSAGE CLASS

The MESSAGE CLASS field specifies the output class to which the system writes system messages and JCL statements for certain jobs the user submits, specifically, jobs submitted: (a) with NOHOLD specified on the SUBMIT command, and (b) without a JOB statement that specifies the MSGCLASS keyword. If this field is blank, the system assigns the message class.

SYSOUT CLASS

The SYSOUT CLASS field specifies the output class the system assigns to SYSOUT (output) data sets the user allocates without specifying an output class. If this field is blank, the system assigns the output class.

UNIT The UNIT field specifies the name of a device or group of devices on which the system puts data sets the user creates without specifying a volume. If this field is blank, the user must specify a volume or unit when creating a data set.

DESTINATION ID

The DESTINATION ID field specifies the ID of either a system output device or a remote workstation. The ID indicates where the system is to route SYSOUT (output) data sets the user dynamically allocates but does not explicitly route. If this field is blank, the user must explicitly route all output data sets.

PERFORMANCE GROUP

The PERFORMANCE GROUP field specifies the performance group the person can request when logging onto the system. If this field is blank, the person has no choice. The system always assigns an installation-defined performance group.

A performance group associates the user's work with a set of performance characteristics that determine how the system treats the work.

USER DATA

The USER DATA field specifies the installation-defined data to be added to the user's entry in the SYS1.UADS data set or the RACF data base.

TSO/E Authorization Information

User type definitions also include the following authorization information. This information controls whether the user can issue various TSO/E commands. Each field contains either Y (for yes) or N (for no). Y grants authorization to use the associated commands, N denies authorization. The fields are all preset to N.

```

ICQADE05          USER TYPES - VIEW AUTHORIZATION INFORMATION
COMMAND ===>

  USER TYPE ..... User

  ACCOUNT ..... N
  JCL ..... N
  MOUNT ..... N
  OPERATOR ..... N
  EDIT RECOVER ..... N
    
```

Figure 18. User Types – View Authorization Information

ACCOUNT

The ACCOUNT field specifies whether the user can issue the ACCOUNT command. Information Center Facility administrators who will be enrolling users must be authorized to use ACCOUNT.

Accessing Currently Defined User Types

JCL The JCL field specifies whether the user can issue the SUBMIT, STATUS, CANCEL, and OUTPUT commands.

MOUNT

The MOUNT field specifies whether the user's dynamic allocation requests are authorized to cause volume mounting, as necessary.

OPERATOR

The OPERATOR field specifies whether the user can issue the OPERATOR command.

EDIT RECOVERY

The EDIT RECOVERY field specifies whether the user can issue the RECOVER parameter on the EDIT command.

RACF Security Information

RACF security information determines the system resources a new user can access. The user is assigned a group and given specific group authority to perform functions within the default group. For more information about RACF groups, see either *z/OS Security Server RACF Security Administrator's Guide*, or your systems support group.

Your installation can use security labels if RACF is installed. To define security labels for users, you must use RACF commands. The Information Center Facility does not support security labels. See *z/OS Security Server RACF Security Administrator's Guide* for information about defining security labels for users.

```
ICQADE08          USER TYPES - VIEW RACF SECURITY INFORMATION
COMMAND ---->

To view the next panel, press ENTER.

USER TYPE ..... User
GROUP OWNER .....
GROUP AUTHORITY ..... U
GROUP ACCESS ..... N
DEFAULT GROUP .....
UNIVERSAL ACCESS ..... N

AUTO DS PROTECT ..... N
OPERATOR ID CARD ..... N
SPECIAL AUTH ..... N
OPERATIONS AUTH ..... N
AUDITOR AUTH ..... N

MODEL DATA SET .....
```

Figure 19. User Types – View RACF Security Information

GROUP OWNER

The GROUP OWNER field identifies the owner of the RACF profile that was created for the user during enrollment. The owner can be a person or a group. If the owner is a person, the field contains that person's user ID. If the owner is a group, it contains the group name. If the GROUP OWNER field is blank, the system uses the user ID of the administrator who enrolls the person.

GROUP AUTHORITY

The GROUP AUTHORITY field specifies the functions the user can perform within the default group (the group identified in the DEFAULT GROUP field). Valid options and the authority each grants are:

- U** USE allows the person to access data sets the group is authorized to access, and to create and RACF-protect data sets.
- CR** CREATE grants USE authority and allows the person to create RACF profiles for data sets that other group members can use.
- CO** CONNECT grants CREATE authority and permits the person to connect other users to the group and to assign any group authority except JOIN.
- J** JOIN grants CONNECT authority and allows the person to add new subgroups to the group and to assign group authorities to new members.

GROUP ACCESS

The GROUP ACCESS field indicates whether group data sets the person creates are to be automatically accessible to other users in the group. Y grants automatic access, N denies it. The field is preset to N.

DEFAULT GROUP

The DEFAULT GROUP field specifies the RACF-defined group to which the person is assigned by default. If the field is blank, the person is assigned to the current connect group of the administrator who enrolls the person.

UNIVERSAL ACCESS

The UNIVERSAL ACCESS field specifies the type of access the system grants all users by default to the data sets the person creates while connected to the default group. Valid options and the type of access each grants are:

- N** NONE prevents other users from accessing the data sets.
- R** READ allows other users to read the data sets.
- U** UPDATE allows other users to update the data sets.
- C** CONTROL allows other users to access VSAM data sets at the control interval (block) level instead of the data set level.
- A** ALTER gives other users full control of the data sets.

AUTO DS PROTECT

The AUTO DS PROTECT field indicates whether the system automatically creates a discrete data set profile for each data set the person creates. Y causes the system to create the profiles, N prevents their creation. The field is preset to N.

OPERATOR ID CARD

The OPERATOR ID CARD field indicates whether the user must insert an operator ID card in a card reader when logging onto the system. (Some terminals have a card reader attachment for reading operator ID cards during LOGON processing. Using operator ID cards is a security feature.) If the field specifies Y, the administrator enrolling the person must insert the same card during enrollment to associate the card with the user. The field is preset to N, which indicates no card is required.

SPECIAL AUTH

The SPECIAL AUTH field indicates whether the user can issue all RACF commands and use all keywords except those that require AUDITOR authority. Y grants SPECIAL authority, N denies it. If the field is set to Y, only administrators who have SPECIAL authority themselves can assign the user type during enrollment. The field is preset to N.

Accessing Currently Defined User Types

OPERATIONS AUTH

The OPERATIONS AUTH field indicates whether the user is authorized to do maintenance on RACF-protected DASD data sets, tape volumes, and DASD volumes. OPERATIONS authority, however, does not override access restrictions imposed by access lists. Y grants OPERATIONS authority, N denies it. The field is preset to N.

AUDITOR AUTH

The AUDITOR AUTH field indicates whether the person can log attempts to access RACF-protected resources and the RACF data set. Y grants AUDITOR authority, N denies it. This field is preset to N.

MODEL DATA SET

The MODEL DATA SET field specifies the name of a data set profile the system is to use when creating new profiles that have the person's user ID as the first-level qualifier. If the field is blank, the system uses no model.

Optional RACF Information

User Type definitions can also contain the following optional RACF information:

```
ICQADE09      USER TYPES - VIEW OPTIONAL RACF INFORMATION
COMMAND ==>>

  USER TYPE ..... User
  Class-authority classes:

Installation data:
```

Figure 20. User Types – View Optional RACF Information

CLASS-AUTHORITY CLASSES

This field contains the names of classes in which the user can define profiles to RACF for protection. Classes you can specify are USER and the classes defined in the RACF Class Descriptor Table.

INSTALLATION DATA

This field contains installation-defined data of up to 255 characters that the system copies into the user's profile.

VSAM DEFINE ALIAS Parameters

User Type definitions can specify two DEFINE ALIAS parameters. If the definition specifies none, the system does not issue the DEFINE ALIAS command when enrolling people assigned the user type. For more information about the DEFINE ALIAS command, see your system support group.

```

ICQADE12          USER TYPES - VIEW USER CATALOG ALIAS
COMMAND ==>>>

USER TYPE ..... User
USER CATALOG NAME .... Fully-qualified name without quotes
MASTER CATALOG NAME .... Fully-qualified name without quotes
    
```

Figure 21. User Types – View User Catalog Alias

USER CATALOG NAME

This field contains the name of the user catalog the ALIAS identifies.

MASTER CATALOG NAME

This field contains the name of the master catalog in which the system puts the ALIAS.

Adding a User Type

To add a user type

1. Type A in the ACTION field of the first user type panel.
2. Type the name and a description of the user type in the USER TYPE and USER DESCRIPTION fields. Your description appears next to the user type name on the panel that lists currently defined user types. Therefore, enter a description that distinguishes the user type from all others.
When finished, press the Enter key.
3. Select the user information you want to specify. After pressing the Enter key, you see fields for that information. For example, if you select the USERID option, you see:

```

ICQADE06          USER TYPES - SPECIFY TSO/E USER ID INFORMATION
COMMAND ==>>>

Type the information where requested, or change the information shown
by typing over it. To proceed to the next panel, press ENTER.

USER TYPE ..... operator

LOGON PROCEDURE  ==>> _____ Required
MIN. REGION SIZE ==>> _____
MAX. REGION SIZE ==>> _____

HOLD CLASS      ==>> -
JOB CLASS       ==>> -
MESSAGE CLASS   ==>> -
SYSOUT CLASS    ==>> -

UNIT            ==>> _____
DESTINATION ID  ==>> _____
PERFORMANCE GROUP ==>> _____
USERDATA       ==>> _____
    
```

Figure 22. User Types – Specify TSO/E User ID Information

4. In the fields displayed, enter the information you want included in the User Type definition. Press the Enter key to temporarily save the information and go to the next panel. Press the Enter key again to return to the User Information

Adding a User Type

Menu panel where you can select another option. When you are finished adding all of the information, press the END PF key to save the User Type definition.

You need not specify information for all three options. If you specify no information for the TSO/E USERID option, the system uses default information during enrollment. If you specify no information for the RACF option or the VSAM DEFINE ALIAS command, the system does not include that information when enrolling people assigned the user type.

Both the TSO/E USERID and the RACF options require two panels. After typing information on the first panel, press the Enter key to see the second panel.

To cancel the additions you have made, type CANCEL after the OPTION arrow on the User Type – Select User Information panel. (You cannot type CANCEL on any of the panels that display information in fields.)

For a description of the information you can specify in a User Type definition, see:

- “TSO/E User ID Information” on page 65
- “TSO/E Authorization Information” on page 67
- “RACF Security Information” on page 68
- “Optional RACF Information” on page 70
- “VSAM DEFINE ALIAS Parameters” on page 70

Modifying a User Type

You can modify any of the information in a User Type definition. Changing the name or description of the user type, however, without considering the people who have already been assigned that user type, can result in inaccurate information in the names directory.

To modify the parameters

1. Type M in the ACTION field of the first user type panel.
2. In the USER TYPE field, identify the user type to be modified. Either type the name of the user type, or request a list of user types and choose one to modify from the list.

After pressing the Enter key, you see:

```
ICQADM17          USER TYPES - SELECT OPTION TO MODIFY
OPTION  ===>  _

Select the desired option:

USER TYPE ..... Administrator

  1  USERID      - TSO/E user ID information
  2  RACF        - RACF security information
  3  ALIAS       - VSAM define user catalog alias
  4  TYPE        - User type and description
```

Figure 23. User Types – Select Option to Modify

3. Select an option to modify. After pressing the Enter key, you see information about that option. For example, if you select the RACF SECURITY option, you see:

```

ICQADE10      USER TYPES - SPECIFY RACF SECURITY INFORMATION
COMMAND =====>

Type the information where requested, or change the information shown
by typing over it. To proceed to the next panel, press ENTER.

USER TYPE .....
GROUP OWNER    =====>
GROUP AUTHORITY =====> U_      Use (U), Create (CR), Connect (CO), Join (J)
GROUP ACCESS   =====> N        (Y/N)
DEFAULT GROUP  =====>
UNIVERSAL ACCESS =====> N      None(N), Read(R), UPDATE(U), CONTROL(C)
                                           or Alter(A)
AUTO DS PROTECT =====> N      (Y/N)
OPERATOR ID CARD =====> N      (Y/N)
SPECIAL AUTH.  =====> N      (Y/N)
OPERATIONS AUTH. =====> N      (Y/N)
AUDITOR AUTH.  =====> N      (Y/N)

MODEL DATA SET =====>
  
```

Figure 24. User Types – Specify RACF Security Information

4. Type over the information to be changed and press the Enter key. When you see the Modify User Information Menu panel, you can select another option to modify. When you are finished making changes, press the END PF key to save them.

Both the TSO/E USERID and the RACF options require two panels. After typing information on the first panel, press the Enter key to see the second.

To cancel the changes you have made, type CANCEL after the OPTION arrow on the User Type Menu panel. (You cannot type CANCEL on any of the panels that display information in fields.)

The following topics describe the parameters each User Type definition can include:

- “TSO/E User ID Information” on page 65
- “TSO/E Authorization Information” on page 67
- “RACF Security Information” on page 68
- “Optional RACF Information” on page 70
- “VSAM DEFINE ALIAS Parameters” on page 70

Deleting a User Type

To delete a user type

1. Type D in the ACTION field of the first user type panel.
2. In the USER TYPE field, identify the user type to be deleted. Either type the name of the user type, or request a list of currently defined user types and select the one to be deleted from the list.

Find the user type you want to delete and type D in the Action field to the left of it. Press the Enter key to see the delete confirmation panel.

Deleting a User Type

```
ICQADE14          USER TYPES - DELETE A USER TYPE
COMMAND ==>>>

The user type to be deleted is displayed below.
To delete the user type, press Enter; to cancel the deletion, press END.

USER TYPE ..... userm
USER DESCRIPTION... user for newproc
```

Figure 25. User Types – Delete a User Type

To delete the user type displayed, press the Enter key. To cancel the delete, press the END PF key.

Chapter 9. Setting System Defaults: ISPF Profile

Overview of Setting System defaults: ISPF Profile

System defaults are preset values the system uses when setting up a user profile in the Information Center Facility. As an administrator, you can create or modify these defaults.

The user's ISPF profile controls communication between the system and the user's terminal. The system copies the system default ISPF profile during enrollment. You can then tailor the copied information to suit the person being enrolled. Among other information, the profile contains:

- Terminal characteristics
- Parameters the Information Center Facility uses when allocating, formatting, and processing the ISPF log and list data sets
- PF key settings

The Information Center Facility uses the system default ISPF profile. ISPF/PDF maintains a set of values that can be modified for each user. Each ISPF/PDF user can modify these defaults by selecting the PDF profile option (usually option 0). The enroll process of the Information Center Facility creates this default set of values for the user being enrolled. You can modify the defaults for the user during the enroll process. You can also modify the initial set of defaults supplied by ISPF/PDF using the SYSDEF option on the Administration main menu panel. When you modify the initial defaults supplied by ISPF/PDF, a local copy of the profile is maintained by the Information Center Facility. In this case, the defaults supplied by ISPF/PDF are no longer used. You may want to change the defaults when the standard defaults no longer apply to the average user being enrolled. Changing the system defaults will require you to do less customization when enrolling users.

For more information about how your profile tables are reset and how the ISPF default profiles are re-synchronized, see “Resynchronizing ISPF Defaults” on page 61.

Before You Begin

Before you begin maintaining the System Default definitions, read the online tutorial. The tutorial describes how to perform the tasks for maintaining the System Default definitions. To read the tutorial, select:

1. The SYSDEF option on the main menu panel for administrators
2. The TUTORIAL option on the System Defaults Menu panel
3. The ISPFDEF option on the Tutorial Menu panel.

For detailed information about using a particular panel, press the HELP PF key while you are on that panel.

Changing the System Default ISPF Profile

To initialize a profile for a new user, the system copies the system default ISPF profile. The system default ISPF profile is either (1) the default profile supplied by ISPF/PDF, or (2) the Information Center Facility customized default profile, if you used the SYSDEF option to modify the ISPF system defaults.

Changing the System Default ISPF Profile

To change the system default ISPF profile:

1. Select the SYSDEF option on the first administrator selection panel and then select the ISPFDEF option.

You must be in full-screen mode when you select the ISPFDEF option. If you attempt to select the ISPFDEF option when you are in split-screen mode, you will receive an error message.

```
ICQAMED1      INFORMATION CENTER FACILITY - SYSTEM DEFAULTS
OPTION  ==>> 1

Select one of the following options.  To scroll, press UP or DOWN.

 0 DESCRIBE   - Read a short description of the options on this panel
 1 ISPFDEF    - Set ISPF system defaults
 2 PRINTER    - Set printer defaults for system
 3 APPLMGR    - System Application Manager
 T TUTORIAL   - Read a detailed description of the options on this panel
```

⋮

To view PF key definitions, type KEYS on COMMAND or OPTION line of any panel.

Figure 26. Information Center Facility – System Defaults

2. Press the Enter key. The ISPF parameter options panel appears. This panel is the ISPF/PDF panel ISPOPTA. Select the category of information you want to change from the list of items on the panel. When you press the Enter key, you will see the current defaults in that category. See *z/OS ISPF User's Guide Vol I* for more information about changing the ISPF defaults.

Note:

- a. You cannot split the screen when you are using the ISPF/PDF defaults dialog to change the system defaults.
- b. Do not use the KEYS command to update your own keys when you are changing the system defaults. During this process, your own profile is inactive. Any modifications to the settings will be made to the currently active profile. When you exit the ISPF/PDF defaults dialog, your own profile will be active again, and you can use the KEYS command to update your keys at this time.

Chapter 10. Setting System Defaults: Printer Support

Overview of Setting System Defaults: Printer Support

The Information Center Facility supplies a printer support service that enables your installation to set up one or more specific print formats for a physical printer. Each print format/physical printer combination is called a *print definition*. When users want to send information to a printer, they can select from a list of print definitions, one that prints their information in an appropriate format.

You can set up a print definition by entering information about print characteristics on Information Center Facility panels. This information is used later as parameters in the TSO/E ALLOCATE or PRINTDS commands, and in JCL OUTPUT and DD statements. Print definitions are stored in the printer support table, an ISPF table named ICQAPT10.

Some of the print characteristics you can use in a print definition are:

- Function – a print routine that can take control when a printer is selected.
- Parameters – parameters for the TSO/E ALLOCATE command or PRINTDS command, and JCL statements.
- Fonts – a list of fonts for the printer.

As an administrator, you can add a new print definition, copy, modify, delete, or test an existing print definition.

The use of the News and Course Abstract printing services requires that printers be defined to the Information Center Facility. If a user attempts to use a print service and a printer is not defined, an error message appears.

Before You Begin

Before you begin maintaining printer support, read the online tutorial. The tutorial describes how to perform the tasks for maintaining the print definitions. To read the tutorial, select:

1. The SYSDEF option on the main menu panel for administrators
2. The TUTORIAL option on the System Defaults Menu panel
3. The PRINTER option on the Tutorial Menu panel.

For detailed information about using a particular panel, press the HELP PF key while you are on that panel.

Creating and Maintaining Default Print Definitions

You can define sets of characteristics for each printer at your installation through Information Center Facility panels. Each definition consists of the printer location, (for example, NY/Bldg-A/Rm-9), a print format (report), and a description of the printer and format (6670 printer, standard reports). By filling in the panels as described in “Adding a Print Definition” on page 79, you can define characteristics for each printer in your installation. These print definitions appear on a list for administrators as follows:

Default Print Definitions

```

ICQAPE00          Printer Support - List of Print Definitions
Command ==>>>                                     Scroll ==>> PAGE

Type an action character in ACTION column or type T (tutorial), A or ADD on the
command line. Action characters: A (add) C (copy) D (delete) M (modify)

Action   Location      Format   Type   System   Printer Name
-   NJ/321/SYS      MAIL    3800   NJTS0/E
-   NJ/321/R88      MAIL    6670   NJVM    LU75$1
-   NJ/321/R88      MEMO    6670   NJVM    LU75$1
-   NJ/327/R12      MAIL    6670   NJTS0/E
-   NY/701/R09      LETTER  6670   NYTS0/E  RMT001
-   NY/922/R23      GENERAL 6670   MVS
-   RI/070/R105     NOTE    6670   MVS
-   RI/127/SYS      REPORT  3800   NJTS0/E  3800
***** END OF LIST *****

```

Figure 27. Information Center Facility – List of Printers for Administrators

When a user wants to print a job, the system can then display these definitions in a list from which the user can select. If a user chose to send mail from a New Jersey printer and requested a list by typing, NJ*, the following list might appear:

```

ICQCPE00          INFORMATION CENTER FACILITY - LIST OF PRINTERS      ROW 11 OF 13
COMMAND ==>>>                                     SCROLL ==>>

To select a printer, type S to the left of the selected printer.

LOCATION      FORMAT      DESCRIPTION
- NJ/321/SYS  MAIL        3800 printer, hand-delivered output
- NJ/321/R88  MAIL        6670 printer, letter with logo
- NJ/327/R12  MAIL        6670 printer, confidential
***** END OF LIST *****

```

Figure 28. Information Center Facility – List of Printers for Users

More than one print definition can apply to one physical printer. Thus, you can have separate definitions specifying different print characteristics for use on the same printer.

You can add a print definition by choosing the Add (A) option, or you can modify an existing print definition by choosing the Modify (M) option. Your installation will, most likely, establish standards on how to fill the various fields of the definition. You should be familiar with these standards before you define or modify a print definition. For example, whoever integrates your existing printing applications with the Information Center Facility can tell you the SYSOUT classes available to you.

At the end of this chapter is a worksheet you can use to plan how to define printers for your installation. For more detailed information on installation and use of print definitions, see *z/OS TSO/E Programming Services*.

Accessing a Print Definition

To access a print definition

1. Select the SYSDEF option on the first administrator selection panel and then select the PRINTER option (option 2).

```

ICQAMED1      INFORMATION CENTER FACILITY - SYSTEM DEFAULTS
OPTION  =====> 2

Select one of the following options.  To scroll, press UP or DOWN.

0  DESCRIBE   - Read a short description of the options on this panel
1  ISPFDEF   - Set ISPF system defaults
2  PRINTER   - Set printer defaults for system
3  APPLMGR   - System Application Manager
T  TUTORIAL  - Read a detailed description of the options on this panel
    
```

To view PF key definitions, type KEYS on COMMAND or OPTION line of any panel.

Figure 29. Information Center Facility – System Defaults

2. After you press the Enter key, you usually see a full list of printers available to your installation. If there are no print definitions, you see a panel where you can add the name of a printer.

```

ICQAPE00      Printer Support - List of Print Definitions
Command =====>                               Scroll =====> PAGE

Type an action character in ACTION column or type T (tutorial), A or ADD on the
command line.  Action characters:  A (add)  C (copy)  D (delete)  M (modify)

Action   Location      Format   Type    System   Printer Name
-----
_  NJ/321/SYS      MAIL    3800    NJTS0/E
_  NJ/321/R88      MAIL    6670    NJVM     LU75$1
_  NJ/321/R88      MEMO    6670    NJVM     LU75$1
_  NJ/327/R12      MAIL    6670    NJTS0/E
_  NY/701/R09      LETTER  6670    NYTS0/E  RMT001
_  NY/922/R23      GENERAL 6670    MVS
_  RI/070/R105     NOTE    6670    MVS
_  RI/127/SYS      REPORT  3800    NJTS0/E  3800
***** END OF LIST *****
    
```

Figure 30. Information Center Facility – List of Printers for Administrators

You can add to the list, modify a printer from the list, delete a printer, or copy the definition of a listed printer.

Adding a Print Definition

To add a new print definition, you generally copy an existing definition. You then modify the copied information to accurately describe the new definition. It is helpful to have available a sample definition to copy for each type of print format.

Adding a Print Definition

After you enter information on the panels, it is stored in the printer support table, ICQAPT10. For more information about the printer definition variables, see *z/OS TSO/E Programming Services*.

When you add, copy, or modify a print definition, information you type is stored only temporarily as you press the Enter key on each of the panels. To finalize additions or modifications, press the END PF key when you return to the panel below.

If you typed M next to a listed definition to modify it, you see:

```
ICQAPM20                      Print Definition
Option ==>>>

Printer Location ..... NY/701/R09
Print Format ..... LETTER
Printer Type..... 6670
Description ..... 6670 printer

Select one of the following options.
To exit press END. To exit without saving, type CANCEL.

1 Identification - Enter or change the printer identification
2 Function       - Choose the print function
3 Parameters     - Enter or change the print function parameters
4 Fonts         - Choose character sets
5 Test          - Test print specifications
```

Figure 31. Printer – Print Definition

The top half of the panel identifies the printer. The bottom half of the panel allows you to select which part of the print definition you want to work with. IDENTIFICATION is the only required option. The other options allow you to specify default values for characteristics such as number of lines per page, tabs, and fonts.

Specifying a Printer Identification

If you typed A or C on the List of Printers panel to add or copy a print definition, or if you selected the IDENTIFICATION option (option 1) from the previous panel, you see:

```

ICQAPE30                               Printer Identification
Command ==>>

Type or change the following information as required.
To continue press ENTER. To exit without saving, press END.

Printer Location ==> NY/701/R09_____ * for list of printer locations
Print Format      ==> LETTER__          * for list of print formats

Printer Type     ==> 6670_____      * for list of printer types
Description      ==> 6670 printer, letter with logo_____

Online          ==> N                (Y/N) Y if print definition available

If the DEST keyword is required, type the following information:
System Name     ==> NYTSO__          System to which printer is attached
Printer Name    ==> RMT001__        Printer name on specified system

```

Figure 32. Printer – Printer Identification

To add a print definition, fill in the fields. To change a copied definition or modify an existing one, type over the information in the fields. Use your installation's established conventions to define printers. Only the PRINTER LOCATION and PRINT FORMAT fields are required. Information from these two fields and from the DESCRIPTION field appears in the list of print definitions that users see.

PRINTER LOCATION

Give the printer's location such as the geographic location (country, state, or city), building, and room number. You can use up to 16 of any characters except single quotes, parentheses, and embedded asterisks.

Note: Information from this field becomes part of the definition displayed to users, so choose a location name that is meaningful.

To see a list of locations used by your installation in other print definitions, type an asterisk (*). To see a partial list, specify part of a location followed by an asterisk, such as ny*. You can then select a location from the list.

For indexing purposes, the combination of PRINTER LOCATION and PRINT FORMAT values must be unique. No other print definition can have the same values for both PRINTER LOCATION and PRINT FORMAT.

PRINT FORMAT

Type a one-word description of the output format. Usually upon installation, your system programmer sets up and names formats available to you. The names are made up of eight alphanumeric and/or special characters with no leading numbers.

Note: Information from this field becomes part of the definition displayed to users.

To see a list of print formats used by your installation in other print definitions, type an asterisk (*). To see a partial list, specify part of a print format followed by an asterisk, such as doc*. You can then select a print format from the list.

PRINTER TYPE

Specify the printer type, such as 6670 or 3800, using up to eight alphanumeric and/or special characters. You may also use one dash (-).

Adding a Print Definition

To see a list of printer types used in other print definitions, type an asterisk (*). To see a partial list, specify part of a printer type followed by an asterisk, for example 66*. You can then select a printer type from the list.

DESCRIPTION

Type information that will help identify the printer to the user. The description might include the printer type and model, and information about how the output will appear. You can type up to 42 characters.

Note: This information appears on the user's Printer Selection panel along with information from the PRINT FORMAT and PRINTER LOCATION fields, so choose a description that is meaningful.

ONLINE

Type Y to specify that the printer is ready for use. Type N to specify that the printer is not ready for use.

When the ONLINE condition is N, the printer will not appear on the user's printer selection list, unless the calling routine (CLIST, TSO/E command, or program) specifies that offline printers be displayed.

SYSTEM NAME

If the remote printer is attached to another system, type the name of the system as it is defined to the JES subsystem. You might need to ask your system programmer for this information. If you specify a name in this field, you must also specify the following one, PRINTER NAME.

PRINTER NAME

Type the name of the remote printer as it is defined to the JES subsystem. You might need to ask your system programmer for this information.

Note: The contents of the two previous fields are used for the TSO/E ALLOCATE DEST parameter. When you specify the system name, the destination is in the format *system name.printer name*. For more information about the format, see *z/OS JES2 Initialization and Tuning Reference*, or *z/OS JES3 Initialization and Tuning Reference*.

Specifying a Print Function

Select the FUNCTION option (option 2) from the Print Definition panel to specify a CLIST, TSO/E command, or program that will send data to the printer when the user selects the print definition. You can also enter any parameters required by the CLIST, command, or program. If your application uses the PRINT option with CLIST ICQCPC10 or ICQCPC15, then you need not enter any parameters on this panel. Instead, you can specify parameters on panels that are displayed when you select the PARAMETERS option shown in Figure 31 on page 80. From those panels, ICQCPC10 automatically retrieves parameters of the TSO/E ALLOCATE command, and ICQCPC15 automatically retrieves parameters of the PRINTDS command.

When you select the FUNCTION option, you see:

```

ICQAPE80                                Print Function
Command ==>>

Printer Location ..... NJ/324
Print Format ..... REPORT
Printer Type ..... 6670
Description ..... Central Computer site

Indicate whether the Print Function uses the PRINTDS command.
To continue press ENTER. To exit without saving, press END.

PRINTDS used ==>> _      If Y, ICQCPC15 can be entered as CLIST Name.
                               If N, ICQCPC10 can be entered as CLIST Name.

Enter or change CLIST, Command or Program name.
CLIST Name ==>> _____ If invoked by a CLIST
Command Name ==>> _____ If invoked by a command
Program Name ==>> _____ If invoked by a program
Parameters ==>> _____

_____

Test ==>> N      (Y/N) Y to test the function
  
```

Figure 33. Printer – Print Function

The Print Function panel fields allow you to specify the calling function whether it is a CLIST, TSO/E command, or a program.

PRINTDS USED

Type Y

To print with parameters of the TSO/E PRINTDS command. If you type Y, you can specify ICQCPC15 as the print function CLIST and you can specify general PRINTDS parameters that are displayed when you select the PARAMETERS option shown in Figure 31 on page 80.

Type N

To specify ICQCPC10 as the print function CLIST and specify parameters of the TSO/E ALLOCATE command and JCL OUTPUT and DD statements that are displayed when you select the PARAMETERS option shown in Figure 31 on page 80.

CLIST NAME

If a CLIST invokes the function, type the CLIST name. IBM supplies two print CLISTs that you can specify: ICQCPC15, which uses the PRINTDS command, and ICQCPC10, which uses the print utility IEBGENER.

COMMAND NAME

If a TSO/E command invokes the function, type the command name.

PROGRAM NAME

If a program invokes the function, type the program name.

PARAMETERS

Type the parameters associated with the CLIST, TSO/E command, or program specified. Do not enter parameters with subfields. (If you are using CLIST ICQCPC10 or ICQCPC15, you do not need to specify parameters in this field.)

TEST The TEST field allows you to invoke the CLIST, TSO/E command, or program to print a data set at the printer so you can verify that it works properly.

Adding a Print Definition

Type Y

To test the print function with its parameters. You then see a panel where you can specify a data set to be printed. If you do not want to test the print function, type N.

Specifying Parameters

To specify print parameters to be used with the print function, select the PARAMETERS option (option 3) from the Print Definition panel. Print parameters are not required information. If you do not type information in the PARAMETER option, the fields default to predetermined system-defined values.

Parameters that you specify are stored as variables in the printer support table. The printer definition variables are listed in *z/OS TSO/E Programming Services*. For information about parameters contained in the variables, see *z/OS MVS JCL Reference*.

The IBM-supplied print functions, ICQCPC10 and ICQCPC15, obtain their parameters from entries on the Parameters panels of the print definition. If you specified a print function and typed N in the PRINTDS USED field shown in Figure 33 on page 83, you see the panels described below in “Specifying General Parameters.”

If you specified a print function and typed Y in the PRINTDS USED field, you see the panels described in “Specifying General PRINTDS Parameters” on page 88.

Specifying General Parameters

The General Parameters panels let you specify print parameters of the TSO/E ALLOCATE command and the JCL OUTPUT and DD statements. The following panel is the first of four panels.

```
ICQAPE50                      General Parameters                      Page 1 of 4
Command ==>>>

Printer Location ..... NY/701/R09
Print Format..... LETTER
Printer Type..... 3380
Description..... 3380 printer, letter with logo

Enter or change the following information as required.
To continue press ENTER. To exit without saving, press END.

SYSOUT Class    ==>> A          A-Z, 0-9, or *
SYSOUT Writer   ==>> _____ SYSOUT writer (if other than JES)
SYSOUT Forms    ==>> W          Forms name for OUTPUT JCL card
OUTDES         ==>> _____ Output descriptor
Data Control    ==>> -          ANSI (A) or MACHINE (M)
UCS            ==>> _____ Character set name to print with
FORMS          ==>> STD3       SYSOUT forms name if special paper required
FCB           ==>> STD3       Forms control image or module name
Line Count     ==>> _____ JES2 maximum number of lines per page
HOLD          ==>> -          (Y/N)
```

Figure 34. Printer – General Parameters

SYSOUT CLASS

Specify the SYSOUT class associated with this printer. Choose from among the output classes that have been established at your location. Valid entries are a single character: A-Z, 0-9, or *. Type * (for JCL OUTPUT and DD statements only) to use the class listed in the MSGCLASS parameter on the job statement.

SYSOUT WRITER

Specify the name of a writer program that modifies system defaults for printing data sets. Valid names have up to eight characters, A-Z, 0-9, \$, #, or @. The first character cannot be 0-9.

SYSOUT FORMS

Specify the name of the forms on which the output data set is to be printed or punched. Valid names have up to eight characters, A-Z, 0-9.

OUTDES

Use this field to specify the name of an OUTPUT statement that you want used with the print definition. The name must be specified in the user's LOGON procedure. Names may have up to 8 characters, A-Z, 0-9, \$, #, or @. The first character cannot be 0-9.

DATA CONTROL

Specify the format of a data control character that appears as the first character of each line of the output data:

- A** – ANSI format
- M** – Machine format.

If no data control character is used, leave this field blank.

UCS Specify the universal character-set (UCS) name for a special character set to be used on a 3211, 3203 Model 5, or 1403 printer. Valid names can have up to four characters: A-Z or 0-9. For a list of the UCS names, see *z/OS MVS JCL Reference*.

FORMS

Type the name of the form on which the output data set is to be printed or punched. Valid form names have up to four characters, A-Z, 0-9, \$, #, @.

FCB Specify a forms control buffer (FCB) specification that stores vertical formatting information for printing. The FCB is the four-character ID of the particular FCB image in SYS1.IMAGELIB. That buffer specifies the lines per inch and page length to be used. IBM provides standard FCB images for specific printers. Valid names can have up to four characters, A-Z, 0-9, \$, #, or @.

LINE COUNT

Type the maximum number of lines JES2 is to print on each page. This number can be from 0 to 255. If you do not specify a number, JES2 will use the default specified at initialization. You can type 0 to keep JES2 from starting a new page when the number of lines exceeds the installation default.

HOLD

If you want the data set to be placed on a HOLD queue before printing, type Y. If you do not want the data set to be placed on a HOLD queue, type N or leave a blank.

Note: If the pre-defined SYSOUT class has a HOLD/NOHOLD condition associated with it, that condition overrides what you type here.

The second panel of the General Parameters is as follows:

Adding a Print Definition

```
ICQAPE51                      General Parameters                      Page 2 of 4
Command ==>>

Printer Location ..... NY/701/R09
Print Format ..... LETTER
Printer Type ..... 3380
Description ..... 3380 printer, letter with logo

Enter or change the following information as required.
To continue press ENTER. To exit without saving, press END.

Module Name      ==> HDS1      Copy-modification module name
Translate Code   ==> _        Table reference character for above
TRC              ==> _        (Y/N) Y indicates OPTCD J
Flash Name       ==> RPT1     Forms Overlay Name
Flash Count      ==> 5_      Number of copies to be flashed
Burst            ==> Y_      (Y/N) Y to burst output
```

Figure 35. Printer – General Parameters

MODULE NAME

Specify the name of a module that will be used to modify and print copies of data sets on the 3800 printer. (Other printers ignore this parameter.) The name can have up to four characters, A-Z, 0-9, @, #, or \$. The module must be predefined with modification information and stored in the SYS1.IMAGELIB data set.

TRANSLATE CODE

Specify a font to be used with the Modify module. The entries are related to the font order numbers used on the Printer – Add or Modify a Font panel. Type 0 for font number 1, 1 for font number 2, 2 for font number 3, and so on.

TRC This option is for the 3800 printer. Type Y to indicate that each line of output data begins with a print control character followed by a table reference character (0, 1, 2, 3, and so on). The table reference character corresponds to a font to be used to print that line.

FLASH NAME

Type the name of the 3800 forms overlay that this output requires to be printed over each page of the output data set. The name can have up to four characters, A-Z, 0-9, @, #, or \$.

FLASH COUNT

Type the number (from 1 – 255) of copies to be printed with the overlay, beginning with the first copy printed. This is only for use with FLASH.

BURST

Type Y

To request that 3800 output be burst (separated at the perforation), trimmed, and stacked. If you do not want the BURST option, type N or leave a blank. This option is ignored for other printers.

The third panel of the General Parameters is as follows:

ICQAPE52		General Parameters		Page 3 of 4	
COMMAND ==>					
Printer Location	NY/701/R09			
Print Format	LETTER			
Printer Type	3380			
Description	3380 printer, letter with logo			
Enter or change the following information as required. To continue press ENTER. To exit without saving, press END.					
Total Copies	==>	___	Total number of copies		
Per Group	==>	___	Copy group values (Sum not to exceed 255)		
Groupid Name	==>	_____	JES2 output group name		
Formdef Name	==>	_____	3800-3 formatting member name		
Pagedef Name	==>	_____	3800-3 page formatting member name		
Index	==>	___	1 to 31 column offset to right		
Left Index	==>	___	1 to 31 column offset to left		

Figure 36. Printer – General Parameters

The fields for the Number of Copies parameter are:

TOTAL COPIES

Type the number of copies of the data set to be printed. Use a number from 1 to 255 in a JES2 system and from 1 to 254 in a JES3 system.

PER GROUP

Use this option with the 3800 when you want to print each page a specified number of times before the next page is printed.

Type the number of times you want each page printed in a complete copy of the data set. You can enter up to eight group values.

Group values can be from 1 to 255 with JES2 and from 1 to 254 with JES3. For 3800 output, this option overrides any entry in the TOTAL COPIES field.

GROUPID NAME

Type the name of an output group to which this output data set belongs. The name can have up to eight characters, A-Z, or 0-9.

FORMDEF NAME

Type the name of a SYS1.IMAGELIB member that contains statements specifying forms to be used in printing the output data set on a 3800-3 printer. The name can have up to six characters, A-Z, 0-9, @, #, or \$.

The member can specify the following:

- Overlay forms to be used in printing
- Location on the page where overlays are to be placed
- Suppressions that can be activated for specified page formats

PAGEDEF NAME

Type the name of a SYS1.IMAGELIB member that contains statements specifying page characteristics for printing the output data set on a 3800-3 printer. The name can have up to six characters, A-Z, 0-9, @, #, or \$.

The page characteristics include logical page length and width, line lengths and lines per page, fonts, page types, and formats.

INDEX

The Index parameter sets the left margin for output on a 3211 printer with the Indexing feature. The width of the line is reduced by the parameter value.

Adding a Print Definition

Type a number from 1 to 31. Type 1 to indicate flush left; type numbers 2 through 31 to indent the print line between 1 and 30 positions to the right. The default is 1, flush left.

The INDEX entry is supported only on JES2 and is only for printing on a 3211 with the Indexing feature.

LEFT INDEX

The Left Index parameter sets the right margin for output on a 3211 printer with the Indexing feature. The width of the line is reduced by the parameter value.

Type a number from 1 to 31. Type 1 to indicate flush right; type number 2 through 31 to move the right margin over by 1 to 30 positions. The default is 1; flush right.

The LEFT INDEX entry is supported only on JES2 and is only for printing on a 3211 with the Indexing feature.

The fourth panel of the General Parameters is as follows:

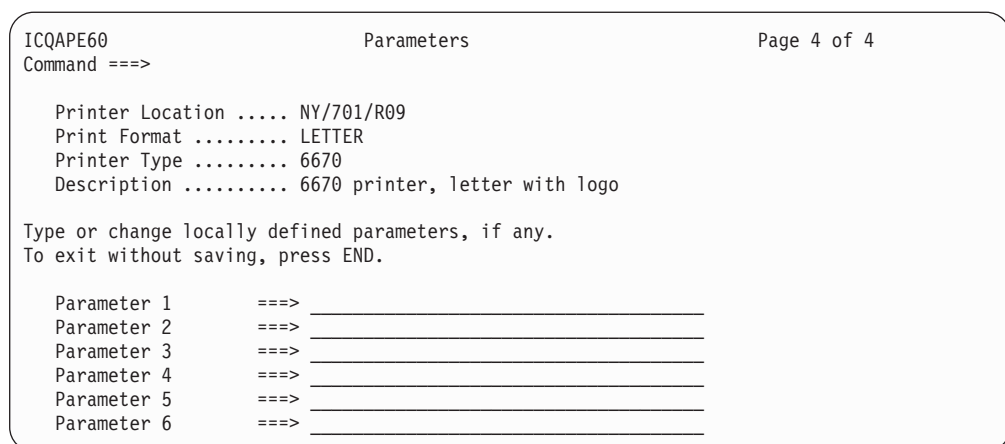

```
ICQAPE60                               Parameters                               Page 4 of 4
Command ===>

Printer Location ..... NY/701/R09
Print Format ..... LETTER
Printer Type ..... 6670
Description ..... 6670 printer, letter with logo

Type or change locally defined parameters, if any.
To exit without saving, press END.

Parameter 1      ===> _____
Parameter 2      ===> _____
Parameter 3      ===> _____
Parameter 4      ===> _____
Parameter 5      ===> _____
Parameter 6      ===> _____
```

Figure 37. Printer – Parameters

This panel allows you to store information about the print definition for use by the calling application or print function.

The information at the top of the panel identifies the print definition. Below it are fields where you can type print parameters specific to this print definition.

Be sure to type parameters and values in their required format.

Specifying General PRINTDS Parameters

The General PRINTDS Parameters panels let you specify parameters of the TSO/E PRINTDS command. For more information about the PRINTDS command, see *z/OS TSO/E Command Reference*.

To view the General PRINTDS Parameters

1. Type Y in the PRINTDS USED field on Figure 33 on page 83.
2. Then type ICQCPC15 in the CLIST NAME field. Press the Enter key to return to Figure 31 on page 80.
3. Select the PARAMETERS option (option 3) in Figure 31 on page 80.

These actions bring you into the series of panels for General PRINTDS Parameters and you see the following panel, the first of six.

```

ICQAPE53          General PRINTDS Parameters          Page 1 of 6
Command ==>>>

Printer Location ..... NY/701/R09
Print Format ..... LETTER
Printer Type ..... 6670
Description ..... 6670 printer, letter with logo

Enter or change the following optional information.
To continue press ENTER. To exit without saving, press END.

OUTDES          ==>> _____ Output descriptor
FORMS          ==>> _____ Special paper required. SYSOUT forms name
DCF            ==>> _ (Y/N) Input is formatted by DCF (SCRIPT)

Members        ==>> _ (Y/N) Y to print members of a PDS
Directory      ==>> _ (Y/N) Y to print PDS directory

To Dataset     ==>> _____
                (Output is directed to dataset without printing)
HOLD           ==>> _ (Y/N) Y to hold data set before printing
    
```

Figure 38. Printer – General PRINTDS Parameters

OUTDES

The OUTDES field allows you to specify the name of an output descriptor that you want used with the print definition. The name must be defined in the user's LOGON procedure or using the TSO/E OUTDES command (JES2 only). Valid names may have up to 8 characters, A-Z, 0-9, \$, #, or @. The first character cannot be 0-9. For information about defining output descriptors on OUTPUT JCL statements, see *z/OS MVS JCL Reference*. For more information about using the TSO/E OUTDES command to dynamically define output descriptors, see *z/OS TSO/E Command Reference*.

FORMS

To specify that the output be printed on a special form, type the name of the form. Valid form names have up to four characters, A-Z, 0-9, \$, #, or @.

DCF

Type Y

If you want data sets formatted by the script command's Document Control Facility (DCF) to be printed using the font information from DCF.

Type N

If you do not want any DCF font information used in printing.

If you do not type a value, Y is assumed. If a data set is not formatted by DCF, or does not have ANSI or machine code carriage control characters, this field is ignored when the data set is printed.

MEMBERS DIRECTORY

These fields correspond to the MEMBERS/DIRECTORY/ALL parameter of the TSO/E PRINTDS command.

To print the members and directory of a partitioned data set (PDS), type Y in both fields or leave them blank. (The directory is a list of the members in the PDS.) To prevent printing either PDS members or directories, type N

Adding a Print Definition

in the appropriate field. DO NOT type N in both fields as this would prevent the printing of any part of a PDS.

TO DATASET

If you want output data to go to a data set instead of being printed, specify the data set in this field. Output data replaces any existing data in the data set. If the specified data set does not exist, the PRINTDS command will attempt to allocate it.

HOLD

Type Y

If you want the data set to be placed in the JES Held Output queue before printing.

Type N

Or leave a blank if you want the data set to be available for printing immediately.

Note: If the pre-defined SYSOUT class has a HOLD/NOHOLD condition associated with it, that condition overrides any value in this field.

The second panel of the General PRINTDS Parameters is as follows:

```
ICQAPE54                PRINTDS - Output Format                Page 2 of 6
Command ==>>>

Printer Location ..... NY/701/R09
Print Format ..... LETTER
Printer Type ..... 6670
Description ..... 6670 printer, letter with logo

Enter or change the following optional information.
To continue press ENTER. To exit without saving, press END.

SYSOUT Class    ==>> _      A-Z, 0-9
Page Length    ==>> _____ Number of lines including margins
Title          ==>> _____ (Y/N) Y to print title on every page
Top Margin     ==>> _____ Number of blank lines at top of page
Bottom Margin  ==>> _____ Number of blank lines at bottom of page
Left Margin    ==>> _____ Number of columns indented on left of page
Maximum Length ==>> _____ Maximum length of the output line
Excess Length  ==>> _____ FOLD or TRUN(truncate) if max length exceeded
Line Spacing   ==>> _____ SINGLE, DOUBLE, TRIPLE space output,
                                     or CONTROL if spacing specified in column 1
```

Figure 39. Printer – PRINTDS – Output Format

SYSOUT CLASS

Type the SYSOUT class that you want used when this print definition is selected. Choose from among the output classes that have been established at your location. Valid entries are a single character: A-Z, 0-9. If you leave a blank, a SYSOUT class of A is assumed, unless TO DATASET was specified on the previous panel.

PAGE LENGTH

Type the number of lines that you want to appear on a page. You can type a number from 1 to 4095. If you do not type a number, a page length of 60 lines is assumed. The page length must include any lines specified in the

TOP MARGIN and BOTTOM MARGIN fields. The page length, less the TOP and BOTTOM MARGIN values, must be at least 3, or at least 6 if a title is printed on each page.

TITLE To print a title on every page of the printed output, type Y. The title includes the name of the data set being printed and the page number. To omit the title, type N. If you leave the TITLE field blank, Y is assumed, unless the data set has carriage control characters or the LINE SPACING field is set to C. If the TITLE field is blank in either of those cases, N is assumed.

TOP MARGIN

Type the number of lines to be left blank at the top of each printed page. You can type a number from 0 to 99. Typing 0 is the same as leaving the field blank. Any TOP MARGIN value other than 0 or a blank is mutually exclusive with a value of C in the LINE SPACING field.

BOTTOM MARGIN

Type the number of lines to be left blank at the bottom of each printed page. You can type a number from 0 to 99. Typing 0 is the same as leaving the field blank. Any BOTTOM MARGIN value other than 0 or a blank is mutually exclusive with a value of C in the LINE SPACING field.

LEFT MARGIN

Type the number of columns that you want the printed output to be indented from the left side of the page. You can type a number from 0 to 99. Typing 0 is the same as leaving the field blank. When printing a partitioned data set (PDS) directory, this margin is ignored.

MAXIMUM LENGTH

This field corresponds to the FOLD/TRUNCATE parameters of the TSO/E PRINTDS command. Type the maximum number of characters that you want to appear in the printed line. If you type FOLD in the following field, lines of input data will continue on the next printed line when they exceed this number. If you type TRUN in the following field, lines of input data will be truncated when they exceed this number.

EXCESS LENGTH

This field corresponds to the FOLD/TRUNCATE parameters of the TSO/E PRINTDS command. Type FOLD if you want the lines of input data to continue on the next printed line when they exceed the value in MAXIMUM LENGTH. Type TRUN if you want the lines of input data to be truncated when they exceed the value in MAXIMUM LENGTH. If you leave the field blank, lines of input data will be truncated when they exceed the output record length as determined by the printer.

LINE SPACING

This field corresponds to the CCHAR/SINGLE/DOUBLE/TRIPLE parameter of the TSO/E PRINTDS command. Use this field to specify line spacing in the printed output. For single spacing, type SINGLE, for double spacing type DOUBLE, for triple spacing, type TRIPLE. If you want ANSI or machine code carriage control characters in the data set to determine line spacing, type CONTROL. If the input data set contains carriage control characters, CONTROL is assumed.

The third panel of the General PRINTDS Parameters is as follows:

Adding a Print Definition

```
ICQAPE55          PRINTDS - Content Description          Page 3 of 6
Command ==>>>

Printer Location ..... NY/701/R09
Print Format ..... LETTER
Printer Type ..... 6670
Description ..... 6670 printer, letter with logo

Enter or change the following optional information.
To continue press ENTER. To exit without saving, press END.

First Line      ==>> ___      Line number of first line to be printed
Last Line       ==>> ___      Last line to be printed or LAST

If printing is to be based on embedded line numbers, enter the following:

First Column    ==>> ___      First column containing embedded line number
Length          ==>> ___      Length of embedded line number
```

Figure 40. Printer – PRINTDS – Content Description

FIRST LINE/LAST LINE

To specify a range of lines to be printed, type the numbers of the first and last lines in the range. To print the first line of a data set, type 1 in the FIRST LINE field. To print to the end of a data set, type LAST in the LAST LINE field. If you are specifying a range of lines using embedded line numbers, fill in the FIRST COLUMN and LENGTH fields.

FIRST COLUMN/LENGTH

These fields correspond to the NUM parameter of the TSO/E PRINTDS command. To print lines based on embedded line numbers, do the following:

- In the FIRST COLUMN field, type the number of the column where embedded line numbers begin.
- In the LENGTH field, type the number of columns that the line number field occupies. The length may not be greater than 8.

The fourth panel of the General PRINTDS Parameters is as follows:

```
ICQAPE56          PRINTDS - Content Description          Page 4 of 6
Command ==>>>

Printer Location ..... NY/701/R09
Print Format ..... LETTER
Printer Type ..... 6670
Description ..... 6670 printer, letter with logo

To print only selected columns, enter or change the following information.
To continue press ENTER. To exit without saving, press END.

From Column    ==>> ___      To Column      ==>> ___
From Column    ==>> ___      To Column      ==>> ___
From Column    ==>> ___      To Column      ==>> ___
From Column    ==>> ___      To Column      ==>> ___
From Column    ==>> ___      To Column      ==>> ___
From Column    ==>> ___      To Column      ==>> ___
From Column    ==>> ___      To Column      ==>> ___
From Column    ==>> ___      To Column      ==>> ___
From Column    ==>> ___      To Column      ==>> ___
From Column    ==>> ___      To Column      ==>> ___
```

Figure 41. Printer – PRINTDS – Content Description

Adding a Print Definition

command. Use this option with the 3800 printer to print each page a specified number of times before the next page is printed. For example, if a data set has five pages and you type:

```
Per Group ==> 2 3
```

the resulting pages are printed in the following order:

```
1,1,2,2,3,3,4,4,5,5, and 1,1,1,2,2,2,3,3,3,4,4,4,5,5,5
```

This option overrides any number in the TOTAL COPIES field.

FCB Specify the name of a forms control buffer (FCB) or image used to store vertical formatting information for printing. The FCB information includes the lines per inch and page length to be used. IBM provides standard FCB images for specific printers. Valid names can have up to four characters, A-Z, 0-9, \$ #, or @.

MODIFY

Specify the name of a module that modifies and prints copies of data sets on the 3800 printer. Other printers ignore this parameter. Valid names can have up to four characters, A-Z, 0-9, \$, #, or @. The module must be predefined with modification information and stored in the SYS1.IMAGELIB data set.

TRANSLATE CODE

This field corresponds to the TRC operand on the MODIFY parameter of the TSO/E PRINTDS command. Specify a font to be used with the Modify module named in the preceding field. The font must be in the list of fonts for the print definition and must have a font order number of 1, 2, 3, or 4. Type 0 to specify font number 3, or 3 to specify font number 4.

TRC For the 3800 printer, to indicate that each line of data begins with a print control character followed by a table reference character (0, 1, 2, or 3), type Y. The table reference character (TRC) corresponds to a font to be used to print that line. To indicate that the data set does not contain TRCs, type N.

Y is assumed if any fonts are defined.

FLASH

Specify the name of a 3800 forms overlay to be printed over each page of the output data set. Valid names can have up to four characters, A-Z, 0-9, \$, #, or @.

FLASH COUNT

Type the number, 0 to 255, of copies to be printed with the overlay on the 3800 printer, beginning with the first copy printed. Leave the field blank to flash all copies.

BURST

To request that output from the 3800 printer be burst into separate sheets, type Y. If you do not want the BURST option, type N or leave a blank. This field requires special hardware on the 3800 and is ignored for other printers.

The sixth panel of the General PRINTDS Parameters is as follows:

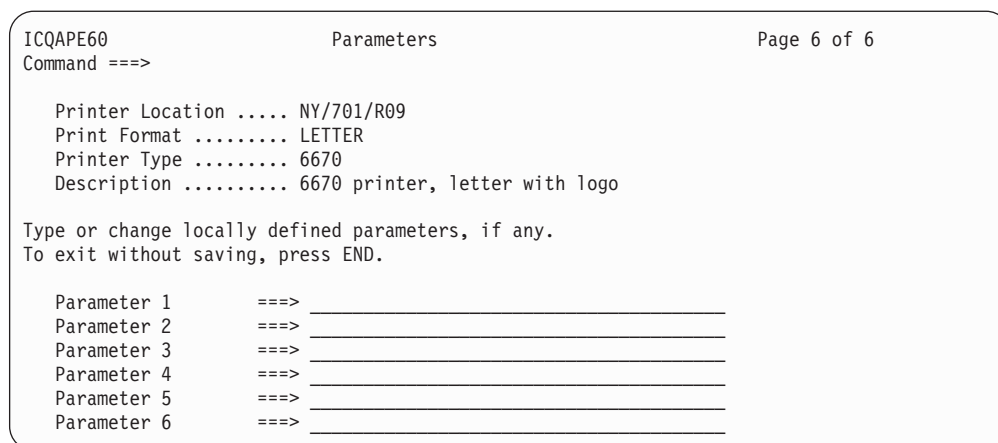

Figure 43. Printer – Parameters

This panel allows you to store information about the print definition for use by the calling application or print function.

The information at the top of the panel identifies the print definition. Below it are fields where you can type print parameters specific to this print definition. Be sure to type parameters and values in their required format.

Specifying Fonts

To change a list of fonts for a print definition, select the FONTS option (option 4) from the Print Definition panel. It is not required information. If you do not type information in the FONTS option, the fields default to predetermined system-defined values.

When you select the FONTS option, you can add, view, modify, or delete fonts. You can specify the fonts to be used with a printer and the default order in which they are to be loaded.

In addition, this option lets you specify whether users who select the print definition may select fonts from the list, and how many they can select.

When you select the FONTS option, you see:

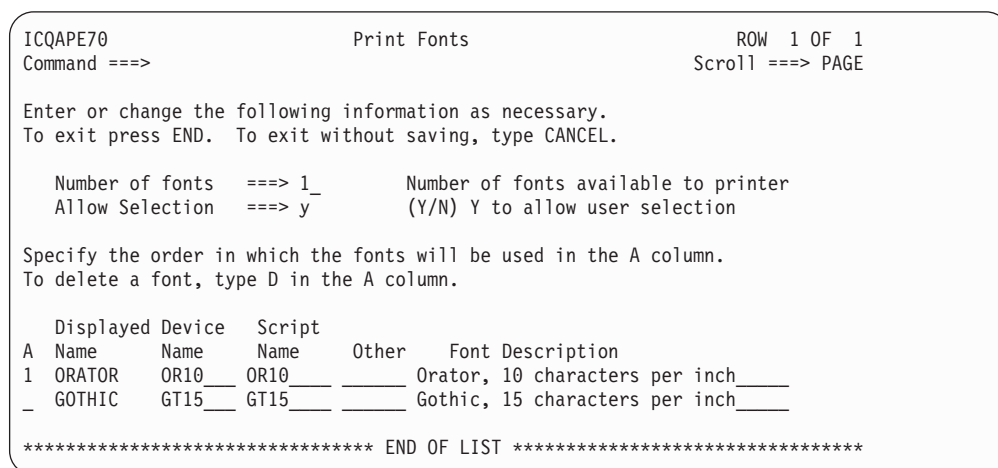

Figure 44. Printer – Print Fonts

Adding a Print Definition

NUMBER OF FONTS

Type the number of fonts from 1 to 99 that the printer can use at one time. Refer to the printer operation instructions for this number. If the field is blank, the maximum of 99 is allowed.

ALLOW SELECTION

Type Y to let users select fonts, or type N to prevent users from seeing a list of fonts. If you type Y, the calling routine (CLIST, TSO/E command, or program) must also specify that the user can select fonts.

Use the following fields to modify or change a list of fonts.

A column

To delete a font, type D in this field next to the font. To record the default font order, type a number in this field beside the desired font. Font order numbers can go up to the limit set in the NUMBER OF FONTS field. Those fonts with order numbers are displayed sequentially at the top of the font list. They are loaded in that order when the printer is selected, unless users change the order.

DISPLAYED NAME (Required field)

Enter the font name as it is to appear to the user. Examples are Courier, Gothic, Orator. You must fill in this field whether or not you permit users to select fonts.

DEVICE NAME (Required field)

Enter the font name as it is known to the system. Refer to printer instructions for the device names of fonts. For example, the device name for Orator on a 3800 printer is OR10.

SCRIPT NAME

Enter the font name that SCRIPT/VS uses to identify the font. For example, Gothic Bold 10 pitch on a 3800 is defined to SCRIPT as GB10. See *DCF SCRIPT/VS Language Reference* for a list of SCRIPT/VS font names. If your installation has created a font that SCRIPT/VS does not know, type an equivalent font name with similar formatting characteristics.

OTHER

Use this field to record special characteristics of the font. For example, use it to indicate that a font is resident or can be loaded for a 6670 printer.

FONT DESCRIPTION

If font selection is permitted, this entry appears on the user's Font Selection panel, along with the font's displayed name. Type a description that will help the user decide whether to choose this font. Include information such as the size of the font, the number of characters per inch, or the use of proportionally spaced characters.

Testing Print Definitions

After adding or modifying a print definition, you should test it by selecting the TEST option (option 5) on the Print Definition panel. If a message appears that tells you the printing was successful, you should verify that the output is at the intended printer before you allow users to access that printer.

The TEST option also tests the print function defined in the FUNCTION option. (You can test the print function directly through the FUNCTION option.) When you select the TEST option, you see:

```

ICQAPE90          Test the Print Definition
Command ==>>>

Enter or change the data set to be printed.  To exit press END.

Project          ==>> _____
Group            ==>> _____
Type             ==>> _____
Member          ==>> _____ Optional if data set is partitioned

Or other partitioned or sequential data set:
Data Set Name   ==>> _____
  
```

Figure 45. Printer – Test the Print Definition

Type the name of a data set to be printed. The data set must be cataloged and not password-protected. When you press the Enter key, the print function is invoked to print the specified data set at the printer.

Use the first four fields to identify a data set and a specific member in it. For example to print JONES.TEST.DATA(MARCH05), type:

```

PROJECT  ==>> jones
FILE NAME ==>> test
FILE TYPE ==>> data
MEMBER   ==>> march05
  
```

Use the last field to specify a data set with more than or fewer than three qualifiers. For example:

```

Other data set
==>> 'jones.test.data.memo(march05)' _____
  
```

This field overrides whatever is in the other fields on the panel.

After you press the Enter key, you see the following panel with information about the test. If an error occurred, error messages are displayed and you can press the HELP PF key to obtain more information.

```

ICQAPE91          Print function test results
Command ==>>>

The test of the print function is completed.  In case of an
error, please take note of the error message (if any) and the
information below for the system programmer.

Printer location..
Print format.....
Print function....
Return code.....
Print data set....
Invocation.....
  
```

Figure 46. Printer – Print Function Test Results

When you leave the Print Function Test Results panel, you return to the panel from which you selected the TEST option.

Deleting a Print Definition

To delete a print definition

1. Select the SYSDEF option on the first administrator selection panel.
2. Select the PRINTER option on the next selection panel. You see a list of print definitions. Type D next to the printer you want to delete and press the Enter key. You then see the Delete Confirmation panel.

```

ICQAPE10                                Delete a Print Definition
Command ==>>

The print definition listed below is to be deleted.
To delete the definition, press ENTER;
to cancel the deletion, press END.

Printer Location ..... NY/701/R09
Print Format ..... LETTER
Printer Type ..... 6670
Description ..... 6670 printer, letter with logo

System Name ..... 6670
Printer Name ..... NYTS0/E
    
```

Figure 47. Printer – Delete a Print Definition

3. To delete the print definition, press the Enter key. If you decide not to delete the print definition, press the END PF key.

Print Definition Worksheet

To determine what print definitions you want, answer the following questions. You might need to discuss some of them with your system programmer.

1. What printers do you use?

*PRINTER NAME	PRINTER LOCATION	**FORMAT	TYPE	DESCRIPTION
RMT001	geo.loc/bldg/rm	letter	6670	letter with logo

Note:

- * The name of the printer as it is known to JES.
- ** One print format of the printer. Upon installation, a system programmer identifies formats available to you. Each line of the above information becomes one print definition. Type the information in the NAME option.

2. Do you want to override the system defaults that control print characteristics, such as lines per page, tabs, output forms, and so on? If so, see “Specifying Parameters” on page 84.
3. Do you want to override the system defaults that control fonts? If so, see “Specifying Fonts” on page 95.
4. Do you have your own CLIST, TSO/E command, or program to send data to the printer? If so, see “Specifying a Print Function” on page 82. For more information, see *z/OS TSO/E Programming Services*.

If you do not have your own CLIST, you may use the supplied CLISTs, ICQCPC10 or ICQCPC15.

Chapter 11. Setting System Defaults: Application Manager

Overview of Setting System Defaults: Application Manager

The Information Center Facility is made up of different services (products and application programs) that users can access. These services can be defined to the Information Center Facility by Application Manager. To be defined by Application Manager, a service must be broken down into parts called applications.

There are three kinds of applications; they are: environments, functions, and panels.

Environments

Support information for the service, such as:

- Commands for setup, invocation, and termination
- Libraries to be allocated
- ISPF shared variables.

Functions

The CLIST, REXX exec, command, program, or menu panel that invokes the service.

Panels The interface allowing users to select different services, tutorials, and HELP information.

Three levels of Application Manager definitions can be available during application invocation or run-time processing. The definitions available at the various levels allow departments, groups, and individual users, to create or tailor their own panels, functions, and environments. The three levels of application definitions are:

System level

Supported for applications that are defined for an entire system.

Group level

Supported for user groups to override system application definitions with definitions tailored to a specific group, and to provide access to applications that are unique to a specific group. (See *z/OS TSO/E Primer* for information about accessing application definitions tailored for a specific group.)

Private level

Supported for individual users to override their group and system application definitions with definitions tailored for their own use. The private level also allows users to create and access application definitions that are unique.

You can add a service to the Information Center Facility by loading installation files that define the service in terms of its applications (environment, function, and panels). You can also add a service by entering specific information on Application Manager panels. After the service is added, you can copy, modify, and delete its applications, and determine where the applications are used. You can also view, replace, and upgrade applications, and generate a hierarchy display for panel applications.

Overview of Setting System Defaults: Application Manager

You can create an installation file from an existing application using the export function. This function copies an existing application into a data set that can be kept on the same system or sent to another system.

You can process multiple installation files with or without upgrade files, and export a list of applications without the use of Application Manager panels. See Chapter 12, “Mass Installation File Processing,” on page 149 for more information.

Before You Begin

Before you begin maintaining Information Center Facility applications, read the online tutorial for Application Manager. The tutorial describes how to perform the tasks for maintaining Information Center Facility applications. To read the tutorial, select:

1. The SYSDEF option on the main menu panel for administrators
2. The TUTORIAL option on the System Defaults Menu panel
3. The Application Manager option on the Tutorial Menu panel.

To read the tutorial for group and private Application Manager, select:

1. The ICFUSER option on the main menu panel for administrators
2. The TUTORIAL option on the Programmer Services panel
3. The Application Manager option for either group or private administrators on the Tutorial Menu panel.

For detailed information about using a particular panel, press the HELP PF key while you are on that panel.

Note:

1. You cannot split the screen while managing applications under Application Manager. You can split the screen while using the other options in the Information Center Facility.
2. Sometimes required libraries for a service defined by Application Manager cannot be accessed and a user cannot invoke the service. The user might also receive a message, such as “Command not found.”. When this situation occurs, see your system programmer. For more information about setting up libraries for invoking an application, see *z/OS TSO/E Customization*.

Managing Multiple Level Applications

During application invocation or run-time processing, up to three levels of application libraries (system, group, private) can be active. The system level library is always active. See *z/OS TSO/E Customization* for more information about activating Application Manager table libraries.

Considerations for Multilevel Applications

The system-level panels, functions, and environments form the base repository for all of the applications that can be invoked. Only one system level repository exists. The system level is activated when you log on to your system.

The group-level panels, functions, and environments form the intermediate repository. There can be many groups defined, but an individual user can use only one group at a time. Any specified group can be used concurrently by numerous users.

To access group level application definitions, you must specify a group name that is used to determine the data set name of a group user library. This option

selection, GROUPSPEC, is available from the Programmer Services panel (Figure 49 on page 106). See *z/OS TSO/E Primer*, for more information about accessing group level application definitions.

The applications at the group level can be definitions that are:

- Copies of system definitions
- Unique group definitions.

The private-level panels, functions, and environments form the lowest-level repository. The applications at this level can be definitions that are:

- Copies of the system or group definitions
- Unique private definitions.

Note: Application selection time increases when you use group and private application definitions.

Applications that Use Other Applications

An application *uses* another application if the first application is defined explicitly to use that application as an option, a startup or terminate function, or an environment. To specify that an application use another application, the application to be used must be defined at the same level or above. For example, a Group Administrator defines a group level function and chooses a system level environment; the system level environment is used by the group level function.

An application can be inherently used during application invocation. For example, if a system level environment for a system level function is copied down to the private level, the system level function, when invoked, can use the private level environment (if the private application library is active). In this case, when you request a 'Where Used List' for the private level environment, the system level function is listed.

When administering at the private level, note that if your applications are dependent on applications defined at the group level, these applications might not be invocable if you run under a different group.

Copying from Level to Level

Application selection time increases when the process of invoking applications crosses from one application level to another. When copying from one level to another, you should copy clusters of applications rather than copying applications that require crossing levels several times. For example, if you plan to copy three applications down to another level, and the three applications are attached to the same panel, you should also copy that panel.

Application Search Order

When you invoke an application using an application name, the order of searching the three levels of administration is from private to group to system. Within the three levels of administration, the order of searching for a matching application name first uses the application and session language among the three levels, then the name and default language among the three levels, and finally the name and no language among the three levels.

Finding the application and the desired language takes precedence over finding the application at the lowest level. The lowest-level application name with the correct language is invoked.

Managing Multiple Level Applications

When you make a selection on an Application Manager panel to invoke options, searching for the application is the same as a search using the application name. Again, the lowest-level application with the correct language is invoked.

When an application keyword is used to invoke an application, the search process is similar to using the application name. The search order among the levels is from private, to group, to system, respective of the language order. If more than one application among the three levels is found to match the keyword, the Applications Matching Keyword panel appears. This panel contains one row for each unique application name and keyword, with the lower-level applications superseding higher-level applications with the same name, language, and keyword.

When an Application Cannot be Executed

Sometimes a user may make a selection and the required applications cannot be executed. When an application is selected, the information required by that application and any applications it uses, must be accessible. For example, a function is dependent on an environment, thus the environment must be accessible. If all the associated information for an application cannot be accessed, invocation does not occur for the selected application. The following situations can cause an individual application to not be executed:

- The application is not verified.
- The application cannot be found.
- An application at the group or private level requires an application at a higher level that does not exist.
- The application is marked 'unavailable'.

Application Manager can be customized to resolve applications differently when unavailable or unverified applications are encountered. See *z/OS TSO/E Customization* for more information.

When an application is not found or is not verified, an invocation error occurs. The Invocation Error panel displays an appropriate error message that identifies the application that cannot be invoked.

Authority Requirements

With a security server such as RACF installed, you need the appropriate authorization to administer the applications that you select.

To administer an existing set of applications, you must have Update authority. To create a new set at the group or private level, you must have Alter authority. The application definitions reside in specific data sets that require you have the appropriate authority.

See *z/OS TSO/E Customization* for a description of how data set names are derived for each application level.

Summary of Valid Operations for each Level of Administration

Valid operations exist for each level of administration on the various levels of applications. You can alter the operations that are valid for applications defined at higher levels than your current level of administration. See *z/OS TSO/E Customization* for more information.

Figure 48 summarizes the operations that are valid, based on the default settings of Application Manager.

	Copy	Modify	Delete	Where	View	Export	Hierarchy
Applications at the Same Level							
Available	Y	Y	Y	Y	Y	Y	Y
Unavailable	Y	Y	Y	Y	Y	Y	Y
Unverified	Y	Y	N	Y	Y	Y	N
Applications at a Higher Level							
Available	Y	N	N	Y	Y	Y	Y
Unavailable	N	N	N	Y	N	N	N
Unverified	N	N	N	N	N	N	N

Figure 48. Default Operations Valid for Each Level of Administration

Invoking Application Manager Dialogs

You use the Application Manager dialogs to define and maintain applications at each administration level (system, group, or private). The following sections describe how to invoke these dialogs depending on your administration level.

Invoking Application Manager Dialogs at the System Level

To administer system applications, you invoke the Application Manager dialogs using the following steps:

1. On the main menu panel for administrators, select the option for setting system defaults (SYSDEF). The System Defaults panel appears in Figure 29 on page 79.
2. On the System Defaults panel, select System Application Manager (APPLMGR). The List of Applications panel (see Figure 52 on page 108) appears with all the system level applications listed in alphabetical order.

You can perform all of the operations listed on the List of Applications panel.

Invoking Application Manager Dialogs at the Group Level

To administer group applications, you invoke the Application Manager dialogs using the following steps:

1. On the User Services panel, select the option for Program Creation/Execution Services (PROGRAM). The Programmer Services panel appears in Figure 49 on page 106.

Invoking Application Manager Dialogs

```
ICQAMED1      TSO/E Information Center Facility - Programmer Services
Option ==>>

Select one of the following options.  To scroll, press UP or DOWN.

0 DESCRIBE    - Read a short description of the options on this panel
1 BASIC       - Program in IBM BASIC/MVS environment
2 APL2        - Program in the APL2 environment
3 VSAPL       - Program in VSAPL environment
4 TIF         - Use the Information Center Facility
5 AS          - Use the Application System
6 GROUPSPEC   - Select the Group Application for the next session
7 GROUP       - TSO/E Group Application Manager
8 PRIVATE     - TSO/E Private Application Manager
T Tutorial    - Read a detailed description of the options on this panel

To view PF key definitions, type KEYS on COMMAND or OPTION line of any panel.
```

Figure 49. Programmer Services Panel

- From the Programmer Services panel, select the option for TSO/E Group Application Manager (GROUP). The Group Identification panel appears in Figure 50.

```
ICQAMEA2      Application Manager - Group Identification
Command ==>>

Type the group ID to administer and press Enter.
To exit, press END.

Group ID ==>> *   Group name, * , or part of name with a * suffix
```

Figure 50. Group Identification Panel

Selecting an Existing Group to Administer

- Enter the GROUP ID of the group you want to administer.

The group identification that you enter can be a complete group ID name, a partial group ID followed by an asterisk (*), or an asterisk (*) by itself.

When you enter a complete group ID on the Group Identification panel, the ID is verified and the List of Applications panel (Figure 52 on page 108) appears with both group and system applications listed in alphabetical order. When you enter an asterisk (*) by itself or as part of the group identification, the List of Groups panel appears.

- On the List of Groups panel, select the group that you want to administer and press the Enter key. The List of Applications panel (Figure 52 on page 108) appears with both group and system applications listed in alphabetical order.

For group level applications, you can perform all of the operations listed on the List of Applications panel. For system level applications, you can only copy, view, export, and generate hierarchy displays and Where Used Lists.

Creating a New Group to Administer

Enter a group name. The group name that you enter must be a valid high-level data set qualifier. The group name is verified and the List of Applications panel (Figure 52 on page 108) appears with system applications listed in alphabetical

order. For group level applications, you can perform all of the operations listed on the List of Applications panel. For system level applications, you can only copy, view, export, and generate hierarchy displays and Where Used Lists.

Invoking Application Manager Dialogs at the Private Level

To administer private applications, you invoke the Application Manager dialogs using the following steps:

1. On the User Services panel, select the option for Program Creation/Execution Services (PROGRAM). The Programmer Services panel appears in Figure 51.

```

ICQAMED1      TSO/E Information Center Facility - Programmer Services
Option  =====>

Select one of the following options.  To scroll, press UP or DOWN.

    0 DESCRIBE      - Read a short description of the options on this panel
    1 BASIC         - Program in IBM BASIC/MVS environment
    2 APL2          - Program in the APL2 environment
    3 VSAPL         - Program in VSAPL environment
    4 TIF           - Use the Information Center Facility
    5 AS            - Use the Application System
    6 GROUPSPEC    - Select the Private Application for the next
                    session
    7 GROUP         - TSO/E Private Application Manager
    8 PRIVATE      - TSO/E Private Application Manager
    T Tutorial     - Read a detailed description of the options on this panel

To view PF key definitions, type KEYS on COMMAND or OPTION line of any panel.
  
```

Figure 51. Programmer Services Panel

2. From the Programmer Services panel, select the option for TSO/E Private Application Manager (PRIVATE).

The List of Applications panel (see Figure 52 on page 108) appears with private, group, and system level applications listed in alphabetical order.

Note: The group applications that appear in the list are derived from the group that is currently active. It is possible to have no group library allocated.

For private level applications, you can perform all of the operations listed on the List of Applications panel. For higher-level applications, you can only copy, view, export, and generate hierarchy displays and Where Used Lists.

Displaying the List of Applications

Administrators at each level (system, group, or private) can invoke the List of Applications panel. The List of Applications panel shows applications that are defined for your administration level and above. The LEVEL column on the panel contains the level of the application.

System Administration

LEVEL column indicates a SYSTEM value for all applications. The applications are listed in alphabetical order by application name.

Displaying the List of Applications

Group Administration

LEVEL column indicates either a GROUP or SYSTEM value depending on the ownership of the application in that row. The applications are listed in alphabetical order by application name. Group level applications are listed above system level applications of the same name.

Private Administration

LEVEL column indicates either a PRIVATE, GROUP, or SYSTEM value depending on the ownership of the application in that row. The applications are listed in alphabetical order by application name. Private level applications are listed first, then group level applications, followed by system-level applications of the same name.

To display the list of applications, invoke the Application Manager dialog for your administrative level. See “Invoking Application Manager Dialogs” on page 105.

Figure 52 shows the List of Applications panel for the private administration level.

```
ICQAME10          Application Manager - List of Applications      ROW 1 OF 10
Command ==>>>                                         SCROLL ==>>>

Type an action character in the A column, or type A or ADD on the command line or
type U or UPGRADE on the command line.
Actions: V (view) C (copy) D (delete) M (modify) W (where used) X (export)
         H (hierarchy)
Note: > before Name indicates application is not available.

==> * _____ * _____ * _____ * _____      For a subset list
                                         or part of field with * suffix

A  Name           Type           Language     Level     Description
-  ADMIN          PANEL          ENGLISH      SYSTEM    Panel for admin personnel
-  CONTROL        ENVIRONMENT    ENGLISH      SYSTEM    Setup for financial programs
-  > ICQENVIRON    ENVIRONMENT    ENGLISH      SYSTEM    ICF Environment
-  ICQFUNC1       FUNCTION       ENGLISH      PRIVATE   This is an ICF function
-  ICQFUNC1       FUNCTION       ENGLISH      GROUP     This is an ICF function
-  ICQFUNC1       FUNCTION       ENGLISH      SYSTEM    This is an ICF function
-  ICQUSER        FUNCTION       ENGLISH      PRIVATE   TSO/E User Services
-  ICQUSER        FUNCTION       ENGLISH      GROUP     TSO/E User Services
-  ICQUSER        FUNCTION       ENGLISH      SYSTEM    TSO/E User Services
-  > MANAGEMENT   PANEL          ENGLISH      SYSTEM    Panel for Managers
*****END OF LIST*****
```

Figure 52. Application Manager – List of Applications

Note:

1. > next to an application name indicates that the application is unavailable to users. To make an application available to users, choose to modify the application and on the first panel displayed, type a Y (yes) in the AVAILABLE field.
2. + next to an application name indicates an application that was loaded with an installation file, but never verified. You must verify the application before it can be made available to users. To find out how to verify an application, see “Adding an Application with an Installation File” on page 111.

Press the END PF key.

To view a specific application

Type V in the Action (A) field next to the application you want to view. You then see a panel from which you can select options to view specific information for that application.

Information you can view depends on the type of application (environment, function, or panel), as follows:

- For an environment:
 - General information
 - Variables defined
 - Libraries required
 - Initialization, invocation, and termination commands provided.
- For a function:
 - General information
 - Variables defined
 - Libraries required
 - Initialization, invocation, and termination commands provided
 - Help text provided.

You can also select an option to test or invoke the specified function.

- For a panel:
 - General information
 - Options defined
 - Help text provided.

You can also select an option to test or invoke the specified panel.

Generating a Hierarchy Display

The Hierarchy Display (H) option is available on the List of Applications panel (see Figure 52 on page 108) and the Where Used List panel (see Figure 87 on page 144). Use the hierarchy display to help you visualize the current display structure of any defined panel application. It can be very helpful when you are managing application definitions.

Type H in the field next to the panel application for which you want the hierarchy display.

Note: If you enter H next to a function or an environment, a message is displayed that indicates hierarchy displays can be derived only from panel applications.

You can then see the Hierarchy Display panel that lists all the panels, functions, and environments (used by the functions) that can be reached from that panel.

Figure 53 on page 110 is an example of a hierarchy display.

Generating a Hierarchy Display

```

ICQAME19  USERID.ICFHIER.LIST - 01.05 -----LINE 000000 COL 001 080
Command ==>>>                                SCROLL ==>> HALF

Name                                         Type           Language      Level
-----
ICQUSER                                     PANEL          ENGLISH      PRIVATE
ICQDESCRIBE                                FUNCTION       ENGLISH      SYSTEM
ICQDESCRIBE                                FUNCTION       ENGLISH      SYSTEM
ICQNAMES                                    FUNCTION       ENGLISH      SYSTEM
  ICQENVIRON                                ENVIRONMENT   ENGLISH      SYSTEM
ICQANALYSIS                                 PANEL          ENGLISH      SYSTEM
  ICQDESCRIBE                                FUNCTION       ENGLISH      SYSTEM
> ICQADRS                                    FUNCTION       ENGLISH      SYSTEM
  ICQCHART                                    PANEL          ENGLISH      SYSTEM
    ICQDESCRIBE                                FUNCTION       ENGLISH      SYSTEM
    ICQICU                                     FUNCTION       ENGLISH      SYSTEM
      ICQENVIRON                                ENVIRONMENT   ENGLISH      SYSTEM
    ICQIMAGE                                    FUNCTION       ENGLISH      SYSTEM
      ICQENVIRON                                ENVIRONMENT   ENGLISH      SYSTEM
    ICQTUTOR                                    FUNCTION       ENGLISH      SYSTEM
  ICQCOURSES                                 FUNCTION       ENGLISH      SYSTEM
    ICQENVIRON                                ENVIRONMENT   ENGLISH      SYSTEM
  ICQPROBLEM                                 FUNCTION       ENGLISH      SYSTEM
  ICQTUTOR                                    FUNCTION       ENGLISH      SYSTEM
  ICQEXIT                                    FUNCTION       ENGLISH      SYSTEM
  
```

Figure 53. Example of Hierarchy Display

Note: > next to an application name indicates that the application is unavailable to users.

The hierarchy is presented in list form with the applications appearing as they would be invoked at run-time. All levels of ownership (system, group, private) currently allocated are shown in the list. When the application is defined for more than one level of administration, only the lowest occurrence equal to or above your level of administration is listed.

By default, when an application on the Hierarchy Display panel is unavailable or is not verified, the application is listed, and processing continues to the next application with no further nesting under the unavailable or unverified application.

If your installation has customized the application search process, and an application on the Hierarchy Display panel is unavailable or is not verified, the system conducts a search to locate the next higher-level library that contains an application with the same name and language. If an application is found, processing continues for any nested applications, and those applications are listed.

When the hierarchy display listings exceed the allowed horizontal space, the generated hierarchy is depicted as:

```

ICQPANEL          PANEL          ENGLISH      SYSTEM
  ICQPANEL2       PANEL          ENGLISH      SYSTEM
    ICQFUNCTION   FUNCTION       ENGLISH      SYSTEM
      *APPLICATION(S) NOT SHOWN
  
```

When a hierarchy display is requested for a panel application that references an application that does not exist, the generated hierarchy is depicted as:

```

ICQPANEL          PANEL          ENGLISH      SYSTEM
  ICQPANEL2       PANEL          ENGLISH      SYSTEM
    ICQFUNCTION   FUNCTION       ENGLISH      *DELETED
  ICQPANELABCD    PANEL          ENGLISH      SYSTEM
  
```

To end displaying a hierarchy

Press the END PF key.

Adding an Application

You can add an application in two ways:

1. **With an Installation File** – Enter the name of the installation file that contains all the information needed to define an application to the Information Center Facility. See *z/OS TSO/E Customization* for an explanation of creating installation files.

You can optionally use the mass installation file process to add applications. See Chapter 12, “Mass Installation File Processing,” on page 149.

2. **Without an Installation File** – Enter the specific information needed to define the application through the Application Manager dialogs.

Each application that you intend to add to your level of administration must be unique in its name and language combination. If this combination is not unique, you can specify a new name and language on the General Information panel for the application to be added.

Adding an Application with an Installation File

The easiest way to add an application is with an installation file. An installation file contains all of the information needed to define an application to the Information Center Facility. A new service might come with installation files. Your system programmer might also create installation files to simplify adding a service to the Information Center Facility. After you load and verify these files, the service can be made available to users as an option on a menu panel.

There are three kinds of installation files, one for each type of application. A line near the beginning of the file indicates whether the installation file is for an environment, a function, or a panel. Other lines in the installation file supply the necessary information to define the application.

Figure 54 on page 112 is an example of an installation file for a function.

Adding an Application

```
*APPLICATION MANAGER INSTALLATION FILE
*SYSTEM                MVS TSO/E
*FUNCTION
*FUNCTION_NAME         ABCLOC
*LANGUAGE              ENGLISH
*KEYWORD               LOCATE
*ENVIRONMENT_NAME     LOCENV
*INVOKING_PANEL       ICQPSTSO
    ENGLISH
    LOC
*POSITION 5
*INVOKING_PANEL       OTHERPAN
    ENGLISH
    1
*AFTER ICQDESCRIBE
    ENGLISH
*ADMIN_DESC            Locate Service
*USER_DESC_1          Find a person's room and floor number
*INVOCATION_COMMAND
    CMD(%LOCATE)
*ISPTUTOR_PANEL       ABCLOC00
*HELP_TEXT
    Select this option to find a person's room and floor number.
    The service prompts you for the person's last name followed by
    the first name or the initial.
```

Figure 54. Example of an Installation File for a Function

When you are adding a service to the Information Center Facility, you will probably have more than one installation file to load. Be sure to load installation files in the following order:

1. Files for environments
2. Files for functions
3. Files for panels

If you do not load files in this order, one of the applications might require a file that has not yet been loaded.

Using the INVOKING_PANEL Entry

Panel and function installation files can include an entry that allows the automatic integration of applications on existing panels. This entry is valid when you are adding and upgrading installation files. The INVOKING_PANEL entry can appear in the file as many times as is necessary to cause the installed application to become an option on panels.

Use INVOKING_PANEL entries to do the following:

- Specify the name and language of the panel on which the application is to become an option.
- Assign a selection identification to the option.
- Designate the location of the option among the existing options.

The following example shows the keywords that are required when using the INVOKING_PANEL entry.

```
*INVOKING_PANEL    panel-name
panel-appl-language
selection-id
*AFTER application-name
application-language
```

OR

```
*INVOKING_PANEL    panel-name
panel-appl-language
selection-id
*POSITION number
```

The following list describes the keywords on the INVOKING_PANEL entry:

panel-name

specifies the name of an existing panel that will include this application as an option. Because attachment is allowed only on panels, no application type is required. If you specify a *panel-name* that does not exist, you receive an error message.

panel-appl-language

specifies the language of the existing panel. This information is required because two panels may exist with the same names but different languages.

selection-id

specifies the selection identification for this application that will appear on the invoking panel. The placement of the option on the panel can be specified using either the *AFTER or the *POSITION keywords.

application-name/application-language

Use the *AFTER keyword to specify the name and language of an existing option on the invoking panel.

number

Use the *POSITION keyword to specify the numeric position of the application to be installed on the panel. If the *POSITION number specified is greater than the number of existing options, the application is placed at the end of the list.

Three conditions must be verified before each INVOKING_PANEL entry is successfully processed. If any of the required conditions are not satisfied, the installation proceeds but the application does not become an option on the specified invoking panel. These conditions are:

- The specified invoking panel must exist on the same administration level as the administrator initiating the installation.
- The selection identification must be unique on the invoking panel.
- The application name and language, used with the *AFTER keyword for placement of the option, must represent an existing option on the invoking panel.

For more information about creating an installation file, see *z/OS TSO/E Customization*.

To load an installation file:

1. Type A on the COMMAND line of the List of Applications panel, and press the Enter key. See Figure 52 on page 108 for an example of the List of Applications panel.
2. You see the menu panel for adding an application. Select the FILE option (option 4) from the menu.

Adding an Application

```
ICQAME13          Application Manager - Add an Application
Option ==> 4

Select one of the following options.  To exit press END.

 1 ENVIRONMENT - Add an environment
 2 FUNCTION    - Add a function
 3 PANEL      - Add a menu panel
 4 FILE       - Add an application using an installation file
```

Figure 55. Application Manager – Add an Application

3. You then see a panel for supplying the name of the data set that contains the installation file. To load the installation file without editing it, type N in the EDIT DATA field.

```
ICQAME80          Application Manager - Installation File
Command ==>

Installation Level.....PRIVATE

Enter or change the following information as necessary.
When finished loading or editing installation data, press END.

Data set:
Project          ==> prefix_   Project owner or data set
File Name        ==> install_  Name or part of name with * suffix
File Type        ==> file_     Name or part of name with * suffix
Member           ==> icqgf004  Member name or part of name with * suffix

Other data set:
==> _____

Edit Data        ==> N          (Y/N) Type Y to edit installation data
```

Figure 56. Application Manager – Installation File

4. After Application Manager finishes loading the installation file, you see a menu panel for defining the application. For example, the figure below shows the menu panel for a function. Select the VERIFY option to guarantee that the information in the installation file is valid, and that all required information is present.

```

ICQAME30          Application Manager - Define a Function
Option ==> 5

Function name ..... ICFFUNC1
Language ..... ENGLISH
Level..... PRIVATE
Description ..... This is an ICF function

Available          ==> N (Y/N) Type Y to make the function available
                   to users

Select one of the following options.
To exit and save changes, press END. To exit without saving, type CANCEL.

 1 GENERAL      - Maintain name, description and other information
 2 VARIABLES    - Maintain variables required by the function
 3 LIBRARIES    - Maintain libraries required by the function
 4 COMMANDS     - Maintain commands which invoke the function
 5 VERIFY       - Verify installation file
 6 HELPTXT      - Maintain help text for the function
 7 TEST         - Invoke the function
    
```

Figure 57. Application Manager – Define a Function

5. If all information in the installation file is valid, and all the needed information is present, you see a message that the verification completed successfully. If some information is not valid, or not all needed information is present, you see additional panels, with messages indicating corrections or additions you must make before you can save the application.

To save the new application: If the verification completed successfully, press the END PF key.

If messages requested changes in or additions to the information from the installation file, make the requested changes or additions on the panel displayed with the message, then press the END PF key.

To cancel verifying the new application: Type CANCEL on the COMMAND line, and press the Enter key. You can later re-verify the application.

To make the application available to users: After the verification has completed and before you press the END PF key to save the application, you make it available to users by changing the N in the AVAILABLE field to Y.

Adding an Application without an Installation File

If you are adding a service to the Information Center Facility, and the service has no installation files, you probably will need a system programmer to provide you with certain information about the service. Use the sample sheets in “Information Sheet for Environments” on page 145 to identify the information you need from a system programmer.

When you are adding a service to the Information Center Facility, you will probably have to define more than one application. Be sure to define applications for a service in the following order:

1. Environments
2. Functions
3. Panels.

If you do not add the applications in this order, one of the applications might require an application that you have not yet added.

Adding an Application

Adding an Environment

1. On the List of Applications panel, type an A on the COMMAND line, and press the Enter key.

Note: The list shows applications that are defined for your level of administration and above. Figure 58 shows the List of Applications panel for the private administration level.

```
ICQAME10          Application Manager - List of Applications      ROW 1 OF 10
Command ==>>>                                         SCROLL ==>>>

Type an action character in the A column, or type A or ADD on the command line or
type U or UPGRADE on the command line.
Actions: V (view) C (copy) D (delete) M (modify) W (where used) X (export)
         H (hierarchy)
Note: > before Name indicates application is not available.

==> * _____ * _____ * _____ * _____ For a subset list
                                         or part of field with * suffix
A  Name          Type          Language   Level      Description
-  ADMIN         PANEL         ENGLISH    SYSTEM     Panel for admin personnel
-  CONTROL       ENVIRONMENT  ENGLISH    SYSTEM     Setup for financial programs
-  > ICQENVIRON   ENVIRONMENT  ENGLISH    SYSTEM     ICF Environment
-  ICQFUNC1      FUNCTION     ENGLISH    PRIVATE    This is an ICF function
-  ICQFUNC1      FUNCTION     ENGLISH    GROUP      This is an ICF function
-  ICQFUNC1      FUNCTION     ENGLISH    SYSTEM     This is an ICF function
-  ICQUSER       FUNCTION     ENGLISH    PRIVATE    TSO/E User Services
-  ICQUSER       FUNCTION     ENGLISH    GROUP      TSO/E User Services
-  ICQUSER       FUNCTION     ENGLISH    SYSTEM     TSO/E User Services
-  > MANAGEMENT  PANEL         ENGLISH    SYSTEM     Panel for Managers
*****END OF LIST*****
```

Figure 58. Application Manager – List of Applications

2. You then see the menu panel for adding an application. Select the ENVIRONMENT option from the menu.

```
ICQAME13          Application Manager - Add an Application
Option ==>> 1

Select one of the following options. To exit press END.

 1 ENVIRONMENT - Add an environment
 2 FUNCTION    - Add a function
 3 PANEL       - Add a menu panel
 4 FILE        - Add an application using an installation file
```

Figure 59. Application Manager – Add an Application

3. You then see the menu panel for defining an environment. Select the options that correspond to input from your information sheet for the environment (see “Information Sheet for Environments” on page 145). The sections below describe each option. You do not need to select the VERIFY option. The VERIFY option applies only to adding environments with installation files.

```

ICQAME35      Application Manager - Define an Environment
Option ==>>

Environment name .....
Language .....
Level ..... PRIVATE
Description .....

Available      ==>> N (Y/N) Type Y to make the environment available
                to users

Select one of the following options.
To exit and save changes, press END. To exit without saving, type CANCEL.

1 GENERAL      - Maintain name, description and other information
2 VARIABLES    - Maintain variables required by the environment
3 LIBRARIES    - Maintain libraries required by the environment
4 COMMANDS     - Maintain commands which invoke the environment
5 VERIFY       - Verify installation file
    
```

Figure 60. Application Manager – Define an Environment

4. To make the environment unavailable to users, change the Y in the AVAILABLE field to N.

Specifying General Information About the Environment: On the menu panel for defining an environment, select the GENERAL option (option 1). You then see a panel on which you can enter general information about the environment from the information sheet for the environment (see “Information Sheet for Environments” on page 145).

```

ICQAME39      Define an Environment - General Information
Command ==>>

Enter or change information as necessary.
To exit and save changes, press END. To exit without saving, type CANCEL.

Environment Name   ==>> ICQENVIRON__
Language           ==>> ENGLISH _
Description        ==>> TSO/E ICF Environment_____
ISPF Application ID ==>> ____

REPLACE application ==>> N (Y/N) Type Y to replace existing application
                    when environment is saved
    
```

Figure 61. Define an Environment – General Information

To save the general information: Press the END PF key on the panel for general information.

To discard the general information: Type CANCEL on the COMMAND line of the panel, and press the Enter key.

To replace the existing general information: Change the N in the REPLACE APPLICATION field to Y.

Setting Variables for the Environment: On the menu panel for defining an environment, select the VARIABLES option (option 2). Type in the names, values, and descriptions of the variables from the information sheet for the environment (see “Information Sheet for Environments” on page 145).

Adding an Application

```
ICQAME32          Variable Definitions          ROW 1 OF 13
Command ==>>>          SCROLL ==>> PAGE

  Application Name .... ICQENVIRON
  Application Type .... ENVIRONMENT

Type an action character in the A column or edit information below.
To exit and save changes, press END. To exit without saving, type CANCEL.
Action Characters: D (delete variable)  M (modify longer value)

  A Name      Value (Line 1)
  Description (Line 2)                                     Trunc
_ QCCDFMT_   mm/dd/yy_____
  Date format as displayed to user_____

_ QCCDFMTX  mm/dd/yy_____
  Date format used internally_____

_ QAMLANGL  DANISH ENGLISH FRENCH GERMAN HANGDBCS ITALIAN KANJDBCS SPANISH
  List of valid languages for applications_____

_____

_____

_____
```

Figure 62. Variable Definitions

To save the variable definitions: Press the END PF key on the panel for variable definitions.

To discard the variable definitions: Type CANCEL on the COMMAND line of the panel for variable definitions, and press the Enter key.

To modify the variable definitions: Type M in the Action (A) field to the left of the variable name, and press the Enter key. You see a panel that allows you to:

- Add more value data for the variable when it exceeds one line.
- View the value data on second or subsequent lines.
- Modify a variable with a long value that contains characters of the double-byte character set (DBCS).
- Modify a variable with a long value so that it can include DBCS characters.

To delete the variable definitions: Type D in the Action (A) field to the left of the variable name, and press the Enter key.

Variables that are truncated: If the variable contains more information than can be displayed on the panel, a T is displayed in the TRUNC field.

Defining Libraries for the Environment: You can define any library required by the environment. To differentiate the libraries specified, a library TYPE column is included on the Application Libraries panel. When defining libraries, you must specify their types. The valid library types are:

- ISPF (for ISPF files)
- CLIST (for CLIST files)
- EXEC (for REXX files)
- INPUT (for any other file with the intended use of input during invocation)

Adding an Application

- OUTPUT (for any other file type with the intended use of output during invocation). Only one data set can be specified for the OUTPUT library type.

To define libraries: On the menu panel for defining an environment, select the LIBRARIES option (option 3). You see the panel for defining application libraries. Type in the information from the information sheet for the environment (see “Information Sheet for Environments” on page 145).

Note: All libraries that you specify must be cataloged in the system before the invocation of the application.

Enter the library type in the TYPE column, ddnames in the NAME column, and the corresponding data sets in the DATA SET column.

If you enclose the data set name in quotes, that name is the fully-qualified data set name that is used during allocation. If you do not enclose the data set name in quotes, the user's TSO/E prefix is used as the high-level qualifier of the data set to be allocated. If the user has used the PROFILE NOPREFIX command, the data set name is used as specified, no matter whether it is enclosed in quotes or not.

Figure 63 shows examples of data sets on the Application Libraries panel.

```

ICQAME33                               Application Libraries                               ROW 1 OF 10
Command ==>>>                           SCROLL ==>>> PAGE

      Application Name .... ICQENVIRON
      Application Type .... ENVIRONMENT

Type an action character in the A column or edit information below.
To exit and save changes, press END. To exit without saving, type CANCEL.
Action Characters: D (delete)  I (insert)  R (repeat)

-----ALLOCATIONS-----
A Type   Name           Data Set (One per line)
-  ISPF__ ISPPLIB       'ICQ.V2R2.ICQPLIB'_____
-                                     'ICQ.V2R1.ICQPLIB'_____
-  CLIST_ SYSPROC      'ICQ.V2R2.ICQACLIB'_____
-                                     'ICQ.GENERAL.CLIB'_____
-  EXEC__ SYSEXEC      'ICQ.V2R2.EXEC'_____
-  INPUT_ ABCLOAD      'ICF.D2.LLIB'_____
-                                     'ICF.GENERAL.LOAD'_____
-  OUTPUT ABCTBLS      'ICF.D2.TLIB'_____
-  INPUT_ USER1_____ USER.REFERENCE_____
-                                     _____
*****END OF LIST*****

```

Figure 63. Application Libraries

To concatenate data sets under one ddname, type:

- A library type in the TYPE column
- The ddname for the list in the NAME column next to the first data set in the list
- A list of data set names, one on each line, in the DATA SET column

To save the application libraries: Press the END PF key on the panel for application libraries.

To discard the application libraries: Type CANCEL on the COMMAND line of the panel for application libraries, and press the Enter key.

Adding an Application

Library Type Characteristics:

For an ISPF library: The ISPF LIBDEF command is used to allocate the ddname for an ISPF library when the application is invoked.

For a CLIST or REXX exec library: The TSO/E ALTLIB command is used to allocate the ddname SYSPROC when the application is invoked.

For a REXX exec library: The TSO/E ALTLIB command is used to allocate the ddname SYSEXEC when the application is invoked.

For an INPUT library: The library is defined using the Supervisory Call for Dynamic Allocation (SVC99) with a disposition of SHR.

For an OUTPUT library: The library is defined using the Supervisory Call for Dynamic Allocation (SVC99) with a disposition of OLD.

During definition, only one data set can be specified for the OUTPUT library type. If OUTPUT is entered and more than one data set is specified, an error message appears.

Invocation Considerations:

For library type INPUT: When an INPUT library is allocated, the file name and list of data sets are recorded. Subsequent applications that reference the same INPUT file name are invoked only when their list of concatenated data sets is an exact match of the initial application. When the last application using that INPUT library terminates, the library is deallocated.

When the library type is INPUT, and the data set information does not match, the second application is not invoked. An error message appears indicating that the requested function cannot be invoked because the required file is in use.

For library type OUTPUT: When the application is finished using a library type OUTPUT, the library is deallocated.

Library type values in installation files: The library type value is also supported in environment installation files.

When an application is exported to create an installation file, the library type value is retrieved and positioned in the LIBRARY entries of the created file. See Figure 64 on page 121 for an example of an environment installation file that includes LIBRARY entries.

Adding an Application

Saving Or Discarding the New Environment:

To save the new environment: Press the END PF key on the panel for defining an environment, Figure 60 on page 117.

To discard the new environment: Type CANCEL on the COMMAND line of the panel for defining an environment, Figure 60 on page 117, and press the Enter key.

Adding a Function

1. On the List of Applications panel, type an A on the COMMAND line, and press the Enter key.

Note: The list shows applications that are defined at your level of administration and above. Figure 66 shows the List of Applications panel for the private administration level.

```
ICQAME10          Application Manager - List of Applications          ROW 1 OF 10
Command ==>>>                                         SCROLL ==>>>

Type an action character in the A column, or type A or ADD on the command line or
type U or UPGRADE on the command line.
Actions: V (view) C (copy) D (delete) M (modify) W (where used) X (export)
         H (hierarchy)
Note: > before Name indicates application is not available.

==> * _____ * _____ * _____ * _____      For a subset list
                                         or part of field with * suffix
A   Name           Type           Language   Level   Description
-   ADMIN          PANEL           ENGLISH    SYSTEM  Panel for admin personnel
-   CONTROL        ENVIRONMENT    ENGLISH    SYSTEM  Setup for financial programs
-   > ICQENVIRON    ENVIRONMENT    ENGLISH    SYSTEM  ICF Environment
-   ICQFUNC1       FUNCTION       ENGLISH    PRIVATE This is an ICF function
-   ICQFUNC1       FUNCTION       ENGLISH    GROUP   This is an ICF function
-   ICQFUNC1       FUNCTION       ENGLISH    SYSTEM  This is an ICF function
-   ICQUSER        FUNCTION       ENGLISH    PRIVATE TSO/E User Services
-   ICQUSER        FUNCTION       ENGLISH    GROUP   TSO/E User Services
-   ICQUSER        FUNCTION       ENGLISH    SYSTEM  TSO/E User Services
-   > MANAGEMENT   PANEL           ENGLISH    SYSTEM  Panel for Managers
*****END OF LIST*****
```

Figure 66. Application Manager – List of Applications

2. You then see the menu panel for adding an application. Select the FUNCTION option (option 2).

```
ICQAME13          Application Manager - Add an Application
Option ==>>> 2

Select one of the following options. To exit press END.

 1 ENVIRONMENT - Add an environment
 2 FUNCTION    - Add a function
 3 PANEL      - Add a menu panel
 4 FILE       - Add an application using an installation file
```

Figure 67. Application Manager – Add an Application

3. You then see the menu for defining a function. Select the options that correspond to input from your information sheet for the function (see “Information Sheet for Functions” on page 146). The sections below describe each option. You do not need to select the VERIFY option. The VERIFY option applies only to adding environments with installation files.

```

ICQAME30          Application Manager - Define a Function
Option ==>>

Function name .....
Language .....
Level ..... PRIVATE
Description .....

Available        ==>> N (Y/N) Type Y to make the function available
                  to users

Select one of the following options.
To exit and save changes, press END. To exit without saving, type CANCEL.

1 GENERAL      - Maintain name, description and other information
2 VARIABLES    - Maintain variables required by the function
3 LIBRARIES    - Maintain libraries required by the function
4 COMMANDS     - Maintain commands which invoke the function
5 VERIFY       - Verify installation file
6 HELPTEXT     - Maintain help text for the function
7 TEST        - Invoke the function
    
```

Figure 68. Application Manager – Define a Function

4. To make the function unavailable to users, change the Y in the AVAILABLE field to N.

Specifying General Information About the Function: On the menu panel for defining a function, select the GENERAL option (option 1). You then see a panel on which you can enter general information about the function from the information sheet for functions (see “Information Sheet for Functions” on page 146).

```

ICQAME31          Define a Function - General Information
Command ==>>

Enter or change information as necessary.
To exit and save changes, press END. To exit without saving, type CANCEL.

Function Name      ==>> ICQNAMES__
Language           ==>> ENGLISH_
Keyword            ==>> NAMES____ Keyword to use on selection panels
Environment Name   ==>> ICFENVIRON Name or part of name with * suffix
ISPF Application ID ==>> _____

Descriptions:
Administrator ==>> Information Center Facility Names
User Panels      ==>> Find a name/phone number_____

REPLACE application ==>>> N (Y/N) Type Y to replace existing application
                    when the function is saved
    
```

Figure 69. Define a Function – General Information

To save the general information: Press the END PF key on the panel for general information.

To discard the general information: Type CANCEL on the COMMAND line of the panel, and press the Enter key.

To replace the existing general information: Change N in the REPLACE APPLICATION field to Y.

Adding an Application

Setting Variables for the Function: On the menu panel for defining a function, select the VARIABLES option. Type in the names, values, and descriptions of the variables from the information sheet for the function (see “Information Sheet for Functions” on page 146).

```
ICQAME32          Variable Definitions          ROW 1 OF 13
Command ==>>>          SCROLL ==>> PAGE

  Application Name .... ICQNAMES
  Application Type .... FUNCTION

Type an action character in the A column or edit information below.
To exit and save changes, press END. To exit without saving, type CANCEL.
Action Characters: D (delete variable) M (modify longer value)

  Value (Line 1)
A Name  Description (Line 2)                               Trunc
ri20AADNUB NO _____
          Administrator Flag _____

_ QAENROLL NO _____
          Enroll Flag _____

- - - - -
          _____
          _____

- - - - -
          _____
          _____

- - - - -
          _____
          _____
```

Figure 70. Variable Definitions

To save the variable definitions: Press the END PF key on the panel for variable definitions.

To discard the variable definitions: Type CANCEL on the COMMAND line of the panel for variable definitions, and press the Enter key.

To modify the variable definitions: Type M in the Action (A) field to the left of the variable name, and press the Enter key. You see a panel that allows you to:

- Add more value data for the variable when it exceeds one line.
- View the value data on second or subsequent lines.
- Modify a variable with a long value that contains characters of the double-byte character set (DBCS).
- Modify a variable with a long value so that it can include DBCS characters.

To delete the variable definitions: Type D in the Action (A) field to the left of the variable name, and press the Enter key.

Variables that are truncated: If the variable contains more information than can be displayed on the panel, a T is displayed in the TRUNC field.

Defining Libraries for the Function: You can define any library required by the function. To differentiate the libraries specified, a library TYPE column is included on the Application Libraries panel. When defining libraries, you must specify their types. The valid library types are:

- ISPF (for ISPF files)
- CLIST (for CLIST files)
- EXEC (for REXX files)
- INPUT (for any other file with the intended use of input during invocation)
- OUTPUT (for any other file type with the intended use of output during invocation). Only one data set can be specified for the OUTPUT library type.

To define libraries: On the menu panel for defining a function, select the LIBRARIES option (option 3). You see the panel for defining application libraries. Type in the information from the information sheet for the function (see “Information Sheet for Functions” on page 146).

Note: All libraries that you specify must be cataloged in the system before the invocation of the application.

Enter the library type in the TYPE column, ddnames in the NAME column, and the corresponding data sets in the DATA SET column.

If you enclose the data set name in quotes, that name is the fully-qualified data set name that is used during allocation. If you do not enclose the data set name in quotes, the user's TSO/E prefix is used as the high-level qualifier of the data set to be allocated. If the user has used the PROFILE NOPREFIX command, the data set name is used as specified, no matter whether it is enclosed in quotes or not.

Figure 71 shows examples of data sets on the Application Libraries panel.

```

ICQAME33                Application Libraries                ROW 1 OF 10
Command ===>                SCROLL ===> PAGE

      Application Name .... ICQNAMES
      Application Type .... FUNCTION

Type an action character in the A column or edit information below.
To exit and save changes, press END. To exit without saving, type CANCEL.
Action Characters: D (delete)  I (insert)  R (repeat)

-----ALLOCATIONS-----
A Type   Name           Data Set (One per line)
-  ISPF__ ISPPLIB        'ICQ.V2R2.ICQPLIB'_____
-  CLIST_ SYSPROC        'ICQ.V2R1.ICQPLIB'_____
-  EXEC__ SYSEXEC        'ICQ.V2R2.ICQACLIB'_____
-  INPUT_ ABCLOAD        'ICQ.GENERAL.CLIB'_____
-  OUTPUT ABCTBLS        'ICQ.V2R2.EXEC'_____
-  INPUT_ USER1_        'ICF.D2.LLIB'_____
-  OUTPUT ABCTBLS        'ICF.GENERAL.LOAD'_____
-  INPUT_ USER1_        'ICF.D2.TLIB'_____
-  INPUT_ USER1_        USER.REFERENCE_____

*****END OF LIST*****

```

Figure 71. Application Libraries

To concatenate data sets under one ddname, type:

- A library type in the TYPE column
- The ddname for the list in the NAME column next to the first data set in the list.
- A list of data set names, one on each line, in the DATA SET column.

To save the application libraries: Press the END PF key on the panel for application libraries.

Adding an Application

To discard the application libraries: Type CANCEL on the COMMAND line of the panel for application libraries, and press the Enter key.

Library Type Characteristics:

For an ISPF library: The ISPF LIBDEF command is used to allocate the ddname for an ISPF library when the application is invoked.

For a CLIST or REXX exec library: The TSO/E ALTLIB command is used to allocate the ddname SYSPROC when the application is invoked.

For a REXX exec library: The TSO/E ALTLIB command is used to allocate the ddname SYSEXEC when the application is invoked.

For an INPUT library: The library is defined using the Supervisory Call for Dynamic Allocation (SVC99) with a disposition of SHR.

For an OUTPUT library: The library is defined using the Supervisory Call for Dynamic Allocation (SVC99) with a disposition of OLD.

During definition, only one data set can be specified for the OUTPUT library type. If OUTPUT is entered and more than one data set is specified, an error message appears.

Invocation Considerations:

For library type INPUT: The file name and list of data sets are recorded. Subsequent applications that reference the same INPUT file name are invoked only when their list of concatenated data sets is an exact match of the initial application. When the last application using that INPUT library terminates, the library is deallocated.

When the library type is INPUT, and the data set information does not match, the second application is not invoked. An error message appears indicating that the requested function cannot be invoked because the required file is in use.

For library type OUTPUT: When the application is finished using a library type OUTPUT, the library is deallocated.

Library type values in installation files: The library type value is also supported in function installation files.

When an application is exported to create an installation file, the library type value is retrieved and positioned in the LIBRARY entries of the created file. See Figure 72 on page 127 for an example of a function installation file that includes LIBRARY entries.

```

*APPLICATION MANAGER INSTALLATION FILE
*SYSTEM              MVS TSO/E
*FUNCTION
*FUNCTION_NAME       ABCLOC
*LANGUAGE            ENGLISH
*KEYWORD             LOCATE
*ENVIRONMENT_NAME    LOCENV
*ADMIN_DESC          Locate Service
*USER_DESC_1        Finds a person's room and floor number
:
:
*LIBRARY             ISPPLIB             ISPF
'ICQ.V2R2.ICQPLIB'
'ICQ.V2R1.ICQPLIB'
*LIBRARY             ISPMLIB             ISPF
'ICQ.MLIB'
*LIBRARY             ICQTABL             ISPF
'ICQ.ICQTABLS'
*LIBRARY             SYSPROC             CLIST
'ICQ.V2R2.ICQACLIB'
'ICQ.GENERAL.CLIB'
*LIBRARY             SYSEXEC             EXEC
'ICQ.V2R2.EXEC'
*LIBRARY             ABCLOAD             INPUT
'ICF.D2.LOAD'
'ICF.GENERAL.LOAD'
*LIBRARY             ABCTBLS             OUTPUT
'ICF.D2.TLIB'
:
:
*HELP_TEXT
Select this option to find a person's room and floor number.
The service prompts you for the person's last name followed by
the first name or the initial.

```

Figure 72. Function Installation File that Includes Library Entries

Defining Commands for the Function: On the menu panel for defining a function, select the COMMANDS option (option 4). You then see the panel for defining application commands. Type in the commands from the information sheet for the function (see “Information Sheet for Functions” on page 146).

Adding an Application

```
ICQAME34                Application Commands                SCROLL ==> PAGE
Command ==>

    Application Name .... ICQNAMES
    Application Type .... FUNCTION

Edit ISPEXEC SELECT command below.
To exit and save changes, press END.  To exit without saving, type CANCEL.

Initialization:
Command ==> _____
_____
_____

Invocation:
Command ==>ICQCAC00_____
_____
_____

Termination:
Command ==> _____
_____
_____
```

Figure 73. Application Commands

To save the application commands: Press the END PF key on the panel for application commands.

To discard the application commands: Type CANCEL on the COMMAND line of the panel for application commands, and press the Enter key.

Providing Help Text for the Function: On the menu panel for defining a function, select the HELPTTEXT option (option 6). You see a panel for providing help text for the function. Type the ISPTUTOR panel name or tutorial command in the appropriate fields and below those fields, type the help text from the information sheet for the function (see “Information Sheet for Functions” on page 146).

```
ICQAME51                Help Text for a Function                Columns 001 058
Command ==>

Enter or change the following information as necessary.  To exit and
save changes, press END.  To exit without saving, type CANCEL.

    ISPTUTOR Panel      ==> ICQTA__  or
    Tutorial Command    ==> _____
_____

***** ***** TOP OF DATA *****
000001 Select this option to view the names directory or to
000002 add, delete, or modify an entry in your private
000003 directory.
***** ***** BOTTOM OF DATA *****
```

Figure 74. Help Text for a Function

To save the help text information: Press the END PF key on the panel for providing help text for the function.

To discard the help text information: Type CANCEL on the COMMAND line of the panel for providing help text for the function, and press the Enter key.

Testing the function: Select the TEST option on the panel for defining a function. The function is invoked just as it would be if a user selected the function from a panel. See “Testing an Application (For Panels and Functions)” on page 143 for more information.

Saving Or Discarding the New Function:

To save the new function: Press the END PF key on the panel for defining a function, Figure 71 on page 125.

To discard the new function: Type CANCEL on the COMMAND line of the panel for defining a function, Figure 71 on page 125, and press the Enter key.

Adding a Panel

1. On the List of Applications panel, type an A on the COMMAND line, and press the Enter key.

Note: The list shows applications that are defined at your level of administration and above. Figure 75 shows the List of Applications panel for the private administration level.

```

ICQAME10          Application Manager - List of Applications      ROW 1 OF 10
Command =====>                                           SCROLL =====>

Type an action character in the A column, or type A or ADD on the command line or
type U or UPGRADE on the command line.
Actions: V (view) C (copy) D (delete) M (modify) W (where used) X (export)
         H (hierarchy)
Note: > before Name indicates application is not available.

==> * _____ * _____ * _____ * _____ For a subset list
or part of field with * suffix
A  Name           Type           Language      Level  Description
-  ADMIN          PANEL          ENGLISH       SYSTEM Panel for admin personnel
-  CONTROL        ENVIRONMENT   ENGLISH       SYSTEM Setup for financial programs
-  > ICQENVIRON    ENVIRONMENT   ENGLISH       SYSTEM ICF Environment
-  ICQFUNC1       FUNCTION      ENGLISH       PRIVATE This is an ICF function
-  ICQFUNC1       FUNCTION      ENGLISH       GROUP   This is an ICF function
-  ICQFUNC1       FUNCTION      ENGLISH       SYSTEM  This is an ICF function
-  ICQUSER        FUNCTION      ENGLISH       PRIVATE TSO/E User Services
-  ICQUSER        FUNCTION      ENGLISH       GROUP   TSO/E User Services
-  ICQUSER        FUNCTION      ENGLISH       SYSTEM  TSO/E User Services
-  > MANAGEMENT   PANEL          ENGLISH       SYSTEM  Panel for Managers
*****END OF LIST*****

```

Figure 75. Application Manager – List of Applications

2. You then see the menu panel for adding an application. Select the PANEL option (option 3).

Adding an Application

```
ICQAME13          Application Manager - Add an Application
Option ==> 3

Select one of the following options.  To exit press END.

  1 ENVIRONMENT - Add an environment
  2 FUNCTION    - Add a function
  3 PANEL      - Add a menu panel
  4 FILE       - Add an application using an installation file
```

Figure 76. Application Manager – Add an Application

3. You then see the menu panel for defining a panel. Select the options that correspond to input from your information sheet for the panel (see “Information Sheet for Panels” on page 147). The sections below describe each option. You do not need to select the VERIFY option. The VERIFY option applies only to adding environments with installation files.

```
ICQAME20          Application Manager - Define a Panel
Option ==>>

Panel name .....
Language .....
Level ..... PRIVATE
Description .....

Available      ==> N (Y/N) Type Y to make the panel available
                to users

Select one of the following options.
To exit and save changes, press END.  To exit without saving, type CANCEL.

  1 GENERAL    - Maintain name, description and other information
  2 OPTIONS    - Maintain options for the panel
  3 VERIFY     - Verify installation file
  4 HELPTEXT   - Maintain help text for the panel
  5 TEST      - Display the panel as the user would see it
```

Figure 77. Application Manager – Define a Panel

4. To make the function unavailable to users, change the Y in the AVAILABLE field to N.

Specifying General Information About the Panel: On the menu panel for defining a panel, select the GENERAL option (option 1). You then see a panel on which you can enter general information from the information sheet for panels (see “Information Sheet for Panels” on page 147).

```

ICQAME21          Define a Panel - General Information
Command ==>>

Enter or change the following information as necessary.
To exit and save changes, press END.  To exit without saving, type CANCEL.

Panel Name       ==>> ICQADMIN_
Language         ==>> ENGLISH_
Keyword          ==>> ICFADMIN_____ Keyword to use on other panels
Panel Title      ==>> TSO/E Information Center Facility Administration
Primary Panel    ==>> Y
Model ISPF Panel ==>> ICQAMED1

Descriptions:
Administrator ==>> TSO/E - Administration_____
User Panels    ==>> Use Information Center Facility Administration_____

Functions:
Startup        ==>> _____ Name or part of name with * suffix
Termination    ==>> _____ Name or part of name with * suffix

REPLACE application ==>> N (Y/N) Type Y to replace existing application
when the panel is saved
  
```

Figure 78. Define a Panel – General Information

To save the general information: Press the END PF key on the panel for general information.

To discard the general information: Type CANCEL on the COMMAND line of the panel, and press the Enter key.

To replace the existing application: Change N in the REPLACE APPLICATION field to Y.

Providing Options for the Panel: On the menu panel for defining a panel, select the OPTIONS option (option 2). You then see a panel for choosing the options. All of the currently defined panels and functions are listed on this panel. At the top of the list are three default options, DESCRIBE, TUTORIAL, and EXIT. You can include any of the other listed panels and functions as options on the new panel.

Note: The options that appear represent the applications that are defined at your level of administration and above. Only the lowest-level application is displayed for applications defined at more than one level. Figure 79 on page 132 shows the Define a Panel – Options panel for the private administration level.

Adding an Application

```
ICQAME26                Define a Panel - Options                ROW 1 OF 7
Command ==>

To add options, type an ID. To remove options, blank the ID.
Action characters: V (view) M (move) with B (before) or A (after).
To exit and save changes, press END. To exit without saving, type CANCEL.

A  ID  Keyword  Name           Language  Level      Description
-  0__ DESCRIBE  ICQDESCRIBE ENGLISH   SYSTEM    Read a short description
-  T__ TUTORIAL  ICQTUTOR    ENGLISH   SYSTEM    Tutorial
-  X__ EXIT      ICQEXIT     ENGLISH   SYSTEM    Exit
-  ___ FIN      FINANCE     ENGLISH   SYSTEM    Panel for financial program
-  ___ FUNC1   ICFFUNC1    ENGLISH   PRIVATE   This is an ICF function
-  ___ PANEL1 ICFPANEL1   ENGLISH   PRIVATE   This is an ICF panel
-  ___ MANAGEMENT PANEL      ENGLISH   SYSTEM    Panel for managers
*****END OF LIST*****
```

Figure 79. Define a Panel – Options

To select an option, type an ID in the ID field next to the function or panel you want. The ID can be one to three characters long and can be any combination of alphabetic A-Z, numeric 0-9, and the special characters #, \$, @. When you press the Enter key, the function or panel is moved up to the beginning of the list.

To view an option: Type a V in the Action (A) field next to the option you want to view. If higher-level applications have been altered or deleted since you last saved this panel, the changes will not be reflected.

To move an option: Type an M in the Action (A) field next to the option you want to move. Type a B or an A next to the option you want to move the other option before or after, and press the Enter key.

To discard an option: Type spaces over the ID next to the option you want to discard, and press the Enter key.

To save the options: Press the END PF key on the panel for providing options for the panel.

To discard the options: Type CANCEL on the COMMAND line of the panel for providing options for the panel, and press the Enter key.

Providing Help Text For the Panel: On the menu panel for defining a panel, select the HELPTXT option (option 4). You see a panel for providing help text for the panel. Type the help text from the information sheet for the panel (see “Information Sheet for Panels” on page 147).

```
ICQAME50                Help Text for a Panel                Columns 001 058
Command ==>

Edit the help text below. To exit and save changes, press END.
To exit without saving, type CANCEL.

***** TOP OF DATA *****
000001 Select this option to access the Information Center
000002 Facility administration services.
***** BOTTOM OF DATA *****
```

Figure 80. Help Text for a Panel

To save the help text information: Press the END PF key on the panel for providing help text for the panel.

To discard the help text information: Type CANCEL on the COMMAND line of the panel for providing help text for the panel, and press the Enter key.

Testing the panel: Select the TEST option on the panel for defining a panel. The panel is displayed with the options you selected. See “Testing an Application (For Panels and Functions)” on page 143 for more information.

Saving Or Discarding the New Panel:

To save the new panel: Press the END PF key on the panel for defining a panel, Figure 77 on page 130.

To discard the new panel: Type CANCEL on the COMMAND line of the panel for defining a panel, Figure 77 on page 130, and press the Enter key.

Creating an Installation File from an Existing Application

You can use the EXPORT (X) option to create an installation file from an existing application. EXPORT copies an application into a data set you name. This data set is *outside* the Application Manager. When the application is in that data set, you can either use it, as is, or edit it to create a new installation file.

You can either keep the installation file on your system or send it to another system. One of the advantages of using the export function is that you can copy an application installed on one system to another system without having to repeat a lengthy installation process. That is, the receiving system can add an application by using the installation file (see “Adding an Application with an Installation File” on page 111).

If this application is already installed across several locations, you can create an upgrade file and distribute or send upgrades to the other locations where local modifications may have been done. See “Upgrading an Installation File” on page 135.

To create an installation file using an existing application

1. From the List of Applications panel, type X in the Action (A) field to the left of the application you want to export, and press the Enter key.

Note: The list shows applications that are defined at your level of administration and above. Figure 81 on page 134 shows the List of Applications panel for the private administration level.

Creating an Installation File

```

ICQAME10          Application Manager - List of Applications      ROW 1 OF 10
Command ==>>>                                           SCROLL ==>>>

Type an action character in the A column, or type A or ADD on the command line or
type U or UPGRADE on the command line.
Actions: V (view) C (copy) D (delete) M (modify) W (where used) X (export)
         H (hierarchy)
Note: > before Name indicates application is not available.

==> * _____ * _____ * _____ * _____      For a subset list
                                           or part of field with * suffix
A  Name          Type          Language   Level   Description
-  ADMIN         PANEL          ENGLISH   SYSTEM  Panel for admin personnel
-  CONTROL       ENVIRONMENT   ENGLISH   SYSTEM  Setup for financial programs
-  > ICQENVIRON   ENVIRONMENT   ENGLISH   SYSTEM  ICF Environment
-  ICQFUNC1      FUNCTION      ENGLISH   PRIVATE  This is an ICF function
-  ICQFUNC1      FUNCTION      ENGLISH   GROUP   This is an ICF function
-  ICQFUNC1      FUNCTION      ENGLISH   SYSTEM  This is an ICF function
-  ICQUSER       FUNCTION      ENGLISH   PRIVATE  TSO/E User Services
-  ICQUSER       FUNCTION      ENGLISH   GROUP   TSO/E User Services
-  ICQUSER       FUNCTION      ENGLISH   SYSTEM  TSO/E User Services
-  > MANAGEMENT  PANEL          ENGLISH   SYSTEM  Panel for Managers
*****END OF LIST*****

```

Figure 81. Application Manager – List of Applications

2. You then see the panel you use to specify the data set into which the application is to be exported. Also, on the panel, you indicate whether you want to replace or edit the data.

```

ICQAME85          Application Manager - Export an Application
Command ==>>>

Application to be exported:
Name .....ICQBASIC
Type .....FUNCTION
Language .....ENGLISH
Level .....SYSTEM
Description .....IBM BASIC/MVS

Specify the data set name into which the application is to be exported:

Data set:
Project          ==> ADMIN4_   Project or owner of data set
File Name        ==> CHANGED_  Name or part of name with * suffix
File Type        ==> FILES_    Name or part of name with * suffix
Member           ==> _____ Member name or part of name with * suffix

Other data set:
==> _____

Replace          ==> Y          (Y/N) Type Y to replace existing data
Edit Data        ==> Y          (Y/N) Type Y to edit installation data

```

Figure 82. Application Manager – Export an Application

Either type the *required* data for DATA SET or OTHER DATA SET. For DATA SET, supply project, file name, file type, and optionally member. If you fill in both DATA SET and OTHER DATA SET, the data set specified for OTHER DATA SET overrides the data set specified for DATA SET.

You can specify either a sequential data set or a partitioned data set (PDS). To display an entire list of data sets, type part of the file name or file type with an asterisk (*) suffix. You see a List of Files panel from which you can select the data set to contain the exported application.

To display an entire list of members for a PDS, leave the MEMBER field blank. Or, to display a partial list of members for a PDS, type part of the member name with an asterisk (*) suffix. You see a List of Members panel from which you can select the member to contain the exported application.

To replace existing data

Type Y in the REPLACE field to replace existing data in the data set or member with the installation file that is created.

To edit the installation file

Type Y in the EDIT DATA field to modify the installation file that is created. If you leave N (no) in this field and press the Enter key, the installation file is stored in the data set.

To save the exported installation file

Press the END PF key after you finish editing the file. A message on the List of Applications panel informs you that the application is exported to the specified data set.

To cancel the creation of an installation file

Type CANCEL on the COMMAND line, and press the Enter key during the edit session. Note that if you type CANCEL after the data set is created (after you press the END PF key), the newly created data set is *not* deleted and remains empty. You can either use this data set at a later time or delete it.

Upgrading an Installation File

You can send services or application definitions to other locations using installation files. Distributing updates to these services at a later time can be done by sending either a new installation file or an upgrade file. An upgrade file is in the format of an installation file and contains instructions for adding, deleting, and replacing portions of an existing installation file.

The following list suggests steps to follow to create an upgrade file:

1. Export the new application definition.
2. Compare the generated installation file with the original installation file that was distributed to your location. Identify the changed entries.
3. Use the ISPF/PDF editor to merge the original and modified entries into a new installation file.
4. Modify the syntax to reflect the syntax of an upgrade file. See “Syntax of Upgrade Files” on page 136 for information.

If you use the upgrade file to apply the changes to the customized application, it is less likely any conflicts will be found between the customization and the upgrade entries.

The following steps describe the process to perform an upgrade on an application:

1. Export the application that you intend to upgrade.
2. Type U or UPGRADE on the COMMAND line of the List of Applications panel.
3. Resolve any conflicts due to the customizing of the application.
4. Type ADD on the COMMAND line of the List of Applications panel to reinstall the upgraded installation file.

Syntax of Upgrade Files

Entries and values in upgrade files and installation files are similar. An asterisk precedes each entry in the upgrade file and each upgrade file begins with a header. Figure 83 shows the header portion of a function, environment, and panel upgrade file.

```
*APPLICATION MANAGER UPGRADE FILE
*SYSTEM          MVS TSO/E
*FUNCTION
*FUNCTION_NAME   ABCFUNCT
*LANGUAGE        ENGLISH
```

OR

```
*APPLICATION MANAGER UPGRADE FILE
*SYSTEM          MVS TSO/E
*ENVIRONMENT
*ENVIRONMENT_NAME ABCENVIR
*LANGUAGE        ENGLISH
```

OR

```
*APPLICATION MANAGER UPGRADE FILE
*SYSTEM          MVS TSO/E
*PANEL
*PANEL_NAME      ABCPANEL
*LANGUAGE        ENGLISH
```

Figure 83. Example of Header Portion of Upgrade Files

All of the entries that follow the header section in an upgrade file specify an operation to add, replace, or delete an entire entry in an installation file. The entry keyword is formed by prefixing ADD_, REPLACE_, or DELETE_ to the name of the entry type on the installation file.

Figure 84 on page 137 shows examples of the general format of operational entries in an upgrade file.

```

*ADD_LIBRARY          ISPPLIB          ISPF
'ICF.V2R2.PLIB'
'ICF.V2R1.PLIB'

      OR

*REPLACE_LIBRARY     ISPPLIB          ISPF
'ICF.V2R1.PLIB'
'ICF.V2R2.PLIB'
*WITH
*LIBRARY              ISPPLIB          ISPF
'ICF.V2R3.PLIB'
'ICF.V2R2.PLIB'
'ICF.V2R1.PLIB'

      OR

*DELETE_LIBRARY      ISPPLIB          ISPF
'ICF.V2R1.PLIB'
'ICF.V2R2.PLIB'

```

Figure 84. Operational Entries in an Upgrade File

Specifying an ADD_ operation

Specify an ADD_ operation in the upgrade file for any existing entry that pertains to the ADD type of entry in the installation file. When you specify an ADD_ operation, the following steps are performed:

1. A search is made of the installation file for any existing entries that conflict with the entry you want to add.

A conflict arises when another entry is found with the same unique values (for example, DDNAME is the unique value for *LIBRARY entries). For entry types that can occur only once (for example, *INIT_COMMAND or any required entry), no unique values exist because the entry itself is unique. If a conflict arises, message lines stating that a duplicate entry was found are added after the lines where the conflicting entry resides. The entry intended to be added is inserted (as comments) into the installation file after the message lines.

The following example shows lines that appear when an *ADD_LIBRARY conflict is encountered:

```

000120 *LIBRARY          ISPPLIB          ISPF
000121 'ICF.FIRST.PLIB'
000122 'ICF.SECOND.PLIB'
==MSG> ADD NOT PERFORMED. DUPLICATE ENTRY FOUND. ICQAM906
000123 /* *LIBRARY      ISPPLIB          ISPF*/
000124 /* 'ICF.OTHER.PLIB'

```

2. If no conflict arises with existing entries, the entry is added. A note line appears preceding the added lines.

The following example shows lines that appear when the *ADD_LIBRARY operation is successful:

```

000122
=NOTE> ADD PERFORMED. THE ENTRY ADDED WAS:   ICQAM905
000123 *LIBRARY          ISPPLIB          ISPF*/
000124 'ICF.OTHER.PLIB'

```

Specifying a REPLACE_ operation

Specify a REPLACE_ operation in the upgrade file with values that match an existing entry of the installation file, the conjunction keyword WITH, and the new

Upgrading an Installation File

entry (entry type and keyword). You do not need to specify the existing text when specifying a REPLACE_ operation for text entries.

When you specify a REPLACE_ operation, the following steps are performed:

1. A search is made of the installation file for the same type entry as the suffix of the REPLACE_ keyword; an entry that also matches the first set of values before the WITH keyword of the upgrade file entry. If no match is found, message lines are added stating the entry that was not located. Text, representing what was to be the new values, is inserted (as comments) into the installation file after the message lines.

The following example shows the lines that appear when a REPLACE_ operation is not successful:

```
000242
==MSG> REPLACE NOT PERFORMED. ENTRY NOT FOUND:    ICQAM909
==MSG> *LIBRARY          ISPPLIB          ISPF
==MSG. 'ICF.V2R2.PLIB'
==MSG> 'ICF.V2R1.PLIB'
==MSG> WAS TO BE REPLACED BY:    ICQAM914
000243 /* *LIBRARY          ISPPLIB          ISPF*/
000244 /* 'ICF.NEW1.PLIB'
000245 /* 'ICF.NEW2.PLIB'
```

2. If the entry that is specified as the first part of the REPLACE_ operation in the upgrade file is found, the entry is replaced with the second set of values from the upgrade file entry. A note line is inserted into the text to indicate that the REPLACE_ operation occurred, and the replaced entry is echoed in note lines.

An example of the lines that appear when a REPLACE_ operation is successful is:

```
000119
=NOTE> REPLACE PERFORMED. THE ENTRY REPLACED WAS:    ICQAM912
=NOTE> *LIBRARY          ISPPLIB          ISPF
=NOTE> 'ICF.OLD1.PLIB'
=NOTE> 'ICF.OLD2.PLIB.'
=NOTE> ENTRY REPLACED WITH:    ICQAM913
000120 *LIBRARY          ISPPLIB          ISPF
000121 'ICF.NEW1.PLIB'
000122 'ICF.NEW2.PLIB'
```

3. If the entry that is specified as the first part of the REPLACE_ operation in the upgrade file is a text entry (ADMIN_DESC, USER_DESC1, USER_DESC2, HELP_TEXT, or ENVIRONMENT_DESC), you do not need to specify the existing text. The new text that is supplied after the WITH entry replaces the previous text. A note line is inserted into the upgraded file to indicate that text was replaced. The replaced text is echoed in note lines, and you can check the old text for customization.

An example of the lines that appear when a REPLACE_ADMIN_DESC is successful is:

```
000119
=NOTE> REPLACE PERFORMED. THE ENTRY REPLACED WAS:    ICQAM912
=NOTE> *ADMIN_DESC          old administrator description
=NOTE> ENTRY REPLACED WITH:
000120 *ADMIN_DESC          new administrator description
```

Specifying a DELETE_ operation

Specify a DELETE_ operation in the upgrade file with values that match an entry of the installation file.

When you specify a DELETE_ operation, the following steps are performed:

1. A search is made of the installation file for an entry of the same type as the suffix of the DELETE_ entry type name; an entry that matches the values specified in the upgrade file entry. If no match is found, message lines are added that show the entry which could not be found.

An example of the lines that appear when a DELETE_ operation is unsuccessful is:

```
000242
==MSG> DELETE NOT PERFORMED. ENTRY NOT FOUND.   ICQAM907
==MSG> *LIBRARY           ISPLLIB           ISPF
==MSG> 'ICF.GONE.PLIB'
000243
```

2. If the entry that is specified is found in the installation file, the entry is replaced by note lines indicating a deletion took place, and the deleted entry is echoed in note lines.

An example of the lines that appear when a DELETE_ operation is successful is:

```
000242
=NOTE> DELETED PERFORMED. THE ENTRY DELETED WAS:   ICQAM908
=NOTE> *LIBRARY           ISPLLIB           ISPF
=NOTE> 'ICF.V2R2.PLIB'
=NOTE> 'ICF.V2R1.PLIB'
000243
```

Encountering an Error in the Upgrade File

If an error is encountered in the upgrade file, you are placed in ISPF Edit for the *upgrade file*. An initial message is displayed indicating that the upgrade failed because the upgrade file contains an error. The cursor is placed on the line of the error (highlighted line) indicating the nature of the error. After you correct the error, the Upgrade File Specification panel is redisplayed and the upgrade process can be reinitiated.

Note: When you are placed in EDIT mode, only one error shows at a time. If more than one error occurred, you must first correct the initial error before a second one will appear.

Initiating the Upgrade Process

Upgrades always process against installation files and are usually performed on exported files. To ensure you use the most current version of your application, select the EXPORT option on the List of Applications panel to create the installation file. After the export is successfully completed, you can select the upgrade process. See “Creating an Installation File from an Existing Application” on page 133 for more information about the export function.

1. To initiate the upgrade process, type U or UPGRADE on the COMMAND line of the List of Applications panel.

Note: The list shows applications that are defined at your level of administration and above. Figure 85 on page 140 shows the List of Applications panel for the private administration level.

Upgrading an Installation File

```

ICQAME10      Application Manager - List of Applications      ROW 1 OF 10
Command ==> U                                          SCROLL ==>

Type an action character in the A column, or type A or ADD on the command line or
type U or UPGRADE on the command line.
Actions: V (view) C (copy) D (delete) M (modify) W (where used) X (export)
         H (hierarchy)
Note: > before Name indicates application is not available.

==> * _____ * _____ * _____ * _____      For a subset list
                                          or part of field with * suffix
A  Name      Type      Language  Level  Description
-  ADMIN     PANEL     ENGLISH  SYSTEM Panel for admin personnel
-  CONTROL   ENVIRONMENT ENGLISH  SYSTEM Setup for financial programs
-  > ICQENVIRON ENVIRONMENT ENGLISH  SYSTEM ICF Environment
-  ICQFUNC1  FUNCTION   ENGLISH  PRIVATE This is an ICF function
-  ICQFUNC1  FUNCTION   ENGLISH  GROUP   This is an ICF function
-  ICQFUNC1  FUNCTION   ENGLISH  SYSTEM  This is an ICF function
-  ICQUSER   FUNCTION   ENGLISH  PRIVATE TSO/E User Services
-  ICQUSER   FUNCTION   ENGLISH  GROUP   TSO/E User Services
-  ICQUSER   FUNCTION   ENGLISH  SYSTEM  TSO/E User Services
-  > MANAGEMENT PANEL     ENGLISH  SYSTEM  Panel for Managers
*****END OF LIST*****

```

Figure 85. Application Manager – List of Applications

- The Application Manager - Upgrade Installation File panel appears in Figure 86.

```

ICQAME88      Application Manager - Upgrade Installation File
Command ==>

Installation file data set:
  Project      ==> Project or owner of data set
  File name    ==> Name or part of name with * suffix
  File Type    ==> Name or part of name with * suffix
  Member       ==> Member name or part of name with * suffix

Other data set:
==>

Edit Data      ==> N          (Y/N) Type Y to edit installation data

Upgrade file data set:
  Project      ==> Project or owner of data set
  File Name    ==> Name or part of name with * suffix
  File Type    ==> Name or part of name with * suffix
  Member       ==> Member name or part of name with * suffix

Other data set:
==>

Edit Data      ==> N          (Y/N) Type Y to edit upgrade data

```

Figure 86. Application Manager - Upgrade Installation File Panel

- On the Upgrade Installation File panel, specify the installation file that is to be upgraded (usually the file that is exported), and the upgrade file itself. An option is provided on this panel to allow you to edit either file. For the EDIT DATA entry, either Y or N must be specified or an error message appears.
- Press the Enter key to initiate the upgrade process. When the upgrade is complete, you are placed in an edit session of the upgraded installation file.

Message lines or note lines appear at the beginning of the upgraded installation file indicating whether the upgrade was successful. Note lines are informational. Message lines indicate that conflicts are found. Two examples are:

```
=NOTE> ----- ICQAM901
=NOTE>   UPGRADE OF THE INSTALLATION FILE ICQFF000 ICQAM902
=NOTE>   WAS SUCCESSFULLY COMPLETED. ICQAM903
=NOTE> ----- ICQAM901

==MSG> ----- ICQAM901
==MSG>   UPGRADE OF THE INSTALLATION FILE ICQFF000 ICQAM902
==MSG>   CONFLICTS FOUND. ICQAM904
==MSG> ----- ICQAM901
```

You can restore the original installation file at any time during the upgrade process. You can either cancel the edit session (no changes are saved), or save the upgrade file and start again by exporting the application.

When the specifications for both files are complete, press the Enter key to initialize the upgrade.

Entries that Can be Upgraded in Function, Environment, and Panel Files

The entries that can be upgraded for the function, environment, and panel files vary. For the required fields, the only valid upgrade action is REPLACE. If you specify an ADD_ or a DELETE_ operation on a required entry, the operation will not be successful and an error message appears.

Either an ADD_, REPLACE_, or DELETE_ operation is executed for each entry in the upgrade file.

Entries that can be updated for Function Installation files are:

```
*KEYWORD                (Required)
*ENVIRONMENT_NAME
*ISPF_APPL_ID
*INVOKING_PANEL
*ADMIN_DESC
*USER_DESC1
*USER_DESC2
*VARIABLE
*LIBRARY
*INIT_COMMAND
*INVOC_COMMAND
*TERM_COMMAND
*HELP_TEXT
*ISPTUTOR_PANEL
*TUTORIAL_COMMAND
```

Entries that can be updated for Environment Installation files are:

```
*ENVIRONMENT_DESC
*ISPF_APPL_ID
*VARIABLE
*LIBRARY
*INIT_COMMAND
*INVOC_COMMAND
*TERM_COMMAND
```

Upgrading an Installation File

Entries that can be updated for Panel Installation files are:

*KEYWORD	(Required)
*PANEL_TITLE	(Required)
*PRIMARY_PANEL	(Required)
*MODEL_ISPF_PANEL	(Required if not ICQAMED1)
*INVOKING_PANEL	
*ADMIN_DESC	
*USER_DESC1	
*USER_DESC2	
*STARTUP_FUNCTION	
*TERM_FUNCTION	
*OPTION	
*HELP_TEXT	

Copying an Application

If an existing application at your administration level or higher is similar to the application you want to add, you can copy the existing application. You must supply a unique name and language combination for the copy of the application at your level. All other changes are optional.

To copy

Type a C on the List of Applications panel, next to the application you want to copy, and press the Enter key. You see the panel for defining the type of application you are copying.

Select the GENERAL option (option 1) and supply a name for the application. If desired, change any of the other information on the panel for supplying general information, and press the END PF key.

Select other options as needed to change the information for the new application.

To test

Select the TEST option on the panel for defining the application. See "Testing an Application (For Panels and Functions)" on page 143 for more information on the TEST option.

To save the new application

Press the END PF key on the panel for defining the application.

To discard the new application

Type CANCEL on the COMMAND line of the panel for defining the application, and press the Enter key.

Note: You cannot copy an unverified application based on the default settings of the Application Manager.

Deleting an Application

You can delete only applications that appear at your level of administration. In addition, the application cannot be used by any other applications at your level. If the application is used by another application on the same level, an error message appears, and the application is not deleted.

To delete

Type a D on the List of Applications panel, next to the application you want to delete, and press the Enter key. If the application doesn't have dependent applications, you see the panel for confirming the deletion of an application.

To confirm the deletion

Press the Enter key on the panel for deleting an application.

To cancel the deletion

Press the END PF key on the panel for deleting an application.

Note: No verification is possible for dependent lower-level applications when applications referenced at a higher level are deleted. You should request a Where Used List or a Hierarchy Display to see dependencies and relationships to other applications before deleting applications.

Testing an Application (For Panels and Functions)

If the application you are copying or modifying is a function or a panel, you can select the TEST option from either the panel for defining panels or the panel for defining functions to invoke the application. The panel or function is invoked just as if you had selected it as an option on a panel.

When you select the TEST option, the application invocations would conform as if they were running outside the Application Manager. A panel being tested can, from one of its options, invoke a panel which internally invokes the original panel being tested.

You cannot test an environment by itself. You can test an environment only through a function that uses it.

Note: If you make changes to the options on a panel, you might see unexpected results under the TEST option until after you save the application.

Modifying an Application

Type an M on the List of Applications panel, next to the application you want to modify, and press the Enter key. You see the panel for defining the type of application you are modifying. Select options as needed to modify the application.

To test

Select the TEST option on the panel for defining the application. See "Testing an Application (For Panels and Functions)" for more information on the TEST option.

To save the modified application

Press the END PF key on the panel for defining the application.

To discard the modifications

Type CANCEL on the COMMAND line of the panel for defining the application, and press the Enter key.

Modifying an Application

Note: If you are modifying a function's keyword (the “word” next to the option number on a menu panel), consider making the modification at a time of day when fewer users are logged on. Users might be confused by a sudden change in the keyword.

Replacing an Existing Application

To replace an existing application, the replacement must have the same name and language combination. Type Y in the REPLACE APPLICATION field on the panel used to define the application (environment, function, or panel).

You can replace an application at your level with an application from your level or from a higher level. You might want to replace an existing application to:

- Make updates, such as a new release
- Use a test version of an application
- Correct an error.

Seeing Where an Existing Application is Used

To see where an application is used

Type a W on the List of Applications panel, next to the application about which you want information, and press the Enter key. You then see a list of applications that use the application you selected. For example, Figure 87 shows a list of applications that use the function, ICQFUNC1.

Note: The applications that appear depend on the level of the application for which you chose the list and whether you have copied the application down from a higher level. An application at a lower level can never be an option for an administrator at a higher level. If you select an application at a higher level, all applications show for your selection.

```
ICQAME17          Application Manager - Where Used List
Command ===>                                           Scroll ===> PAGE

The following FUNCTION is used by the applications listed below.

Name ..... ICQFFUNC1
Level ..... PRIVATE
Description ..... This is an ICF function

Type an action character in the A column. To exit press END.
Action characters: V (view) D (delete) M (modify) W (where used) H (hierarchy)
Note: > before Name indicates application is not available.

==> * _____ * _____ * _____ For a subset list, type field
or part of field with * suffix
A  Name      Type      Language  Level    Description
-  FINANCE   PANEL    ENGLISH   SYSTEM   Financial panel
-  MANAGEMENT PANEL    ENGLISH   SYSTEM   Management panel
-  ICQPANEL1 PANEL    ENGLISH   PRIVATE  An ICF panel
-  ICQPANEL1 PANEL    ENGLISH   GROUP    An ICF panel
-  > SPREADSHEET PANEL    ENGLISH   SYSTEM   Spreadsheet panel
*****END OF LIST*****
```

Figure 87. Application Manager – Where Used List

You can modify or delete these applications in the same way you modify or delete applications from the full list of applications. For information about modifying and deleting applications, see “Modifying an Application” on page 143 and “Deleting

an Application” on page 142. You can see where an application in the Where Used List is used by typing W in the Action (A) field to the left of the application.

You can view the application by typing V in the Action (A) field to the left of the application. You can request to display the hierarchy of a panel by typing H in the Action field. See “Generating a Hierarchy Display” on page 109 for more information.

To end seeing where an application is used

Press the END PF key.

Sample Information Sheets

On the following pages are sample sheets showing information necessary to define an environment (“Information Sheet for Environments”), function (“Information Sheet for Functions” on page 146), and panel (“Information Sheet for Panels” on page 147). This information is necessary only if you do not have installation files for the applications.

You can photocopy these sheets and give them to your system programmer to write down the information you need. Each heading (such as General Information) corresponds to the panel on which you enter the information.

Information Sheet for Environments

General Information:		
Environment Name (required)	...	(1-12 alphanumeric or special characters (\$, #, @), first character alphabetic or special)
Language (required)	...	
Brief Description (required)	...	
ISPF Application ID (optional)	...	(1-4 alphanumeric or special characters (\$, #, @), first character must be alphabetic)

Variables the Environment Sets (optional):		
The following variables are set in the ISPF shared variable pool when a function using this environment is invoked.		
Variable Name	Value	Description
...
...
...
...
...
...

Libraries the Environment Requires (optional):
Fill in the libraries the environment requires. Include the library type, ddname, and the data set name. Indicate concatenation by including more than one data set for one ddname.

Sample Information Sheets

Libraries the Environment Requires (optional):		
Library Type	Ddname	Data Set Name

Commands the Environment Executes (optional):		
Fill in the ISPEXEC SELECT commands the environment executes. The environment must have an invocation command if functions using it do not.		
Initialization Command		...
Invocation Command		...
Termination Command		...

Information Sheet for Functions

General Information:		
Function Name (required)		...
Language (required)		...
Keyword (option name on a panel) (required)		...
Name of Environment Function Requires (optional)		
ISPF Application ID (optional)		...
Descriptions on administrator panels (required)		...
Descriptions on user panels (required)		...

Variables the Function Sets (optional):		
The following variables are set in the ISPF shared variable pool when this function is invoked.		
Variable Name	Value	Description

Libraries the Function Requires (optional):
 Fill in the libraries the function requires. Include the library type, ddname, and the data set name. Indicate concatenation by including more than one data set for one ddname.

Library Type	Ddname	Data Set Name

Commands the Function Executes (optional):
 Fill in the ISPEXEC SELECT commands the function executes. The function must have an invocation command if functions using it do not.

Initialization Command	...
Invocation Command	...
Termination Command	...

Help and Tutorial For the Function (optional):
 If a tutorial exists for the function, either supply the ISPTUTOR panel name for the first panel in the tutorial, or supply the command to invoke the tutorial.

ISPTUTOR panel or Invocation Command for Tutorial	...
HELP Text For Function (used in the DESCRIBE option)	...

Information Sheet for Panels

General Information:

Panel Name (required)	...	(1-12 alphanumeric or special characters (\$, #, @), first character alphabetic or special)
Language (required)	...	
Keyword (option name on a panel) (required)	...	(1-11 alphanumeric or special characters (\$, #, @), first character alphabetic)
Panel Title (required)	...	
Is this a primary panel (main menu)? (required)	...	
Model ISPF Panel (if not ICQAMED1) (required)	...	
Descriptions on administrator panels (required)	...	
Descriptions on user panels (required)	...	
Startup functions (optional)	...	
Termination functions (optional)	...	

Sample Information Sheets

Options (optional): Write in the functions and panels that are to appear as options on the panel.	
Option ID	Keyword
...	...
...	...
...	...
...	...
...	...
...	...

Help For the Panel (optional): HELP Text Used in the DESCRIBE option
--

Chapter 12. Mass Installation File Processing

Overview of Mass Installation File Processing

The mass installation file process simplifies both the installation of applications and the maintenance of these applications across several locations. It allows you to upgrade and/or install multiple installation files at one time and export a list of applications without the use of Application Manager panels. This process can save you time and effort when sets of applications that are defined at one location must be installed at another location.

The mass installation file process operates under the batch terminal monitor program (TMP) in an ISPF environment, but the process does not require administration panel interaction. This process can be submitted to run in MVS batch. In addition, if ISPF is not currently active, the mass installation file process will activate ISPF.

Note: To use the mass installation file process, you must have the appropriate access to the specified application tables.

The mass installation file process is capable of the following:

- Loading one or more installation files into the Application Manager administrator and user table data sets
- Verifying loaded applications
- Making applications available to you and other users
- Automatically replacing applications of the same name, type, and language
- Performing backup of any replaced applications
- Upgrading one or more installation files
- Automatically exporting an application into an installation file
- Exporting a list of applications from the Application Manager administrator and user table data sets
- Documenting all successful operations
- Documenting all exceptions

Functions of the Mass Installation File Process

The mass installation file process provides two separate functions. The functions are:

- **Mass upgrade and install**

This function uses upgrade and/or installation files to upgrade or replace existing applications and install new applications. The updated and new installation files are placed into the Application Manager administrator's and users' table data sets. Each installed application is verified and made available.

You can mass process installation files with or without corresponding upgrade files. You can also mass process upgrade files with or without corresponding installation files.

- **Mass export**

This function uses a list of applications to drive an automated export process. Applications are exported to the output installation library.

Functions of Mass Installation File Process

The mass installation file process terminates when all of the operations are completed or a severe error occurs. When an individual operation (upgrade, install, export) is not successful, messages that document the operation are written as inline messages to the ISPF log and processing continues with the next file. If processing is run in batch, inline messages are written to the SYSTSPRT file and processing continues.

You can invoke the mass installation file process in the batch TMP (no active terminal) or in the foreground (active terminal). If you run the process in an interactive session, the messages appear on the terminal.

Mass Upgrade and Install

The upgrade and installation process depends on whether upgrade and/or installation files exist.

When both upgrade and installation files exist, upgrade files are processed against matching installation files and then the updated installation files are installed. Each installed application is verified and made available. Matching is done on the application name, language, and type. If conflicts are found during the upgrade of an installation file, the conflict is documented in the ISPF log and also in the terminal output stream. Processing of the current installation file is discontinued. Processing continues with the next installation file.

When an upgrade file exists without a matching installation file, the identified application is automatically exported, upgraded, installed, verified, and made available. The application is exported to the output installation library with a unique member name.

When an installation file exists without a matching upgrade file, the installation file is installed. Each installed application is verified prior to being made available.

When you request backup and an application in the Application Manager administrator and user table data sets is to be replaced during an installation, that application is exported to the backup installation library with a unique member name before it is replaced.

When the mass upgrade and installation process is complete, the successfully processed applications are available to on-line users. Each of the applications has a corresponding file in the output installation library that is equivalent to the final contents of the modified application. If BACKUP(YES) was specified, the backup files will be installation files corresponding to the original version of each application that was modified during the process.

Mass Export

The mass export function exports applications from the Application Manager administrator and user table data sets into the output installation library. The applications to be exported are specified in the mass export list of applications file. The member names that are assigned to the installation files placed in the output installation library by the export process may be specified in the mass export list of applications file. If the member name is not specified in the file or if that member name is not unique, a unique member name is constructed.

The mass export list of applications file must be a sequential file containing one record for each application to be exported. See "Creating a Mass Export List of Applications File" on page 152 for more information.

Messages Pertaining to Processing

The results of all mass installation file processing are directed to your ISPF log and to the terminal output stream. This includes any informational and error messages that you would receive when you export, upgrade, or load applications using the Information Center Facility Application Manager. Other messages identify successful exports, upgrades to installation files, updates to the Application Manager administrator and user table data sets, and unsuccessful operations. See *z/OS TSO/E Messages* for explanations of these messages.

Using the Mass Installation File Process

The following sections describe considerations for using the mass installation file process, and list the required and optional input, and the output.

Considerations for mass installation file processing

Consider the following before you attempt to process multiple installation files:

- Installation files must reside in a partitioned data set.
- The output installation library must be a partitioned data set.
- Upgrade files must reside in a partitioned data set.
- If MODE(EXP) is specified, the export list file must be a sequential file and must contain at least one entry.
- Required files and application repositories must be pre-allocated.
- The process cannot be used when Application Manager administrator and user table data sets are being updated.
- Administrator and user table libraries must be paired.
- The process does not initialize Application Manager table data sets.
- The process does not provide error correction capabilities.
- Detail message lines or note lines that appear in the upgraded installation file are not available.

Input for mass installation file processing

The following lists the required and optional input for mass installation file processing:

- Installation file data set (OPTIONAL)
- System Application Manager administrator and user table data sets (REQUIRED)
- Other system files (OPTIONAL)
- Upgrade file data set (OPTIONAL)
- Backup file data set (OPTIONAL); REQUIRED if you specify BACKUP
- List of applications file for mass export (OPTIONAL); REQUIRED if you specify MODE(EXP)

Output for mass installation file processing

The mass installation file process has the following output:

- Original installation files and upgrade files
- New and upgraded installation files
- New and modified tables within the Application Manager administrator and user table data sets
- Backup installation files, if requested
- ISPF log list
- Terminal output stream documenting successful operations and all exceptions

Creating a Mass Export List of Applications File

When you specify the MODE(EXP) parameter, the mass installation file process exports applications in the form of installation files. The exported installation files are placed in the partitioned data set that is used for the output installation files. The names of the applications to be exported are listed in a control file specified by the file name (ddname) ICQEXPT.

The control file, ICQEXPT, has the following format requirements:

- The file must be a sequential, fixed, or variable file. If a partitioned data set is allocated, the allocation must be on a member basis. For example:

```
//ICQEXPT DD DSN=ICQ.EXPORT.LIST(MEMBER1),DISP=SHR:
```
- Each record in the file denotes a single export request, and continuation is not allowed.
- Up to four parameters per record make up the individual export request. The parameters are positional but not column sensitive. The first three parameters are required.
- Each parameter is a sequential character string bounded by one or more blanks.
- The parameters must be specified in the first 72 characters of the record.
- If all four parameters are specified, any character strings beyond the fourth parameter are ignored.
- If /* are the first characters in the record, the record is ignored and treated as a comment.
- Blanks are ignored.

There can be up to four positional parameters on each export request record. The first three parameters are required. These parameters must be specified in the following order:

1. Application name (Required)
Specifies the name of the application to be exported as it is specified in the Application Manager tables.
2. Language (Required)
Specifies the defined language of the application to be exported. Valid values are:
CHSDBCS CHTDBCS DANISH ENGLISH FRENCH GERMAN HANGDBCS ITALIAN
KANJDBCS PORTUGUE SPANISH
3. Type (Required)
Specifies the type of application to be exported. The following types are valid values for the English version of the product:
 - PANEL
 - FUNCTION
 - ENVIRONMENTThese values are translated for each of the supported languages.
4. Member name
Specifies the member name of the installation file to be exported. If the name specified is not unique in the output data set, a unique name is generated. The name is generated by truncating the member name to 6 characters and appending the first available two-digit suffix. If the actual length of the member name is less than 6 characters, the first available suffix is appended to the actual name.

If the member name is not specified, the installation member name is generated based on the name of the application following the same procedure as previously described.

Figure 88 shows an example of the mass export list of applications file.

```
/* Application
/* Name      Language      Type      Member Name

ICQENVIRON  ENGLISH      ENVIRONMENT  ICQFF000

/* The above entry will cause an installation member named
/* ICQFF000 to be created.

ICQDESCRIBE ENGLISH      FUNCTION

/* The above entry will cause an installation member named
/* ICQDESCR to be created.

ICQDESCRIBE ENGLISH      PANEL

/* The above entry will cause an installation member named
/* ICQDES01 to be created because the default name, ICQDESCR
/* already exists.
```

Figure 88. Example of Mass Export List of Applications File

Invoking the Mass Installation File Process

You can invoke the mass installation file process either in MVS batch or in the foreground.

Batch Invocation

You can write an MVS batch job that uses a JCL procedure to invoke the mass installation process and then submit this job to run under the terminal monitor program (TMP). The job can be submitted using the TSO/E SUBMIT command or an equivalent method of job submission.

A sample JCL procedure, ICQMIFP, is provided in SYS1.SAMPLIB and contains the default values for required files and parameters. Your installation may modify this procedure when placing it in your system procedure library. Your job can use ICQMIFP as is, or you can provide installation written JCL to override default parameter values. Default library values may also be modified using standard JCL statements in the batch job. “Installation Example for Mass Installation File Processing” on page 155 shows the sample JCL procedure ICQMIFP and provides an example of installation written override JCL. See *z/OS MVS JCL Reference*, and *z/OS MVS JCL User’s Guide*, for information about how to override parameters specified in a JCL procedure.

ICQMIFP executes the REXX exec, ICQAMRMI, which is the main mass installation file processing module. When ICQAMRMI is invoked in batch, a temporary ISPF profile is allocated and batch ISPF is started.

Foreground Invocation

You can invoke the mass installation process in the foreground by directly invoking the REXX exec, ICQAMRMI, which is the main mass installation file processing module. On the invocation, you can specify any parameters whose values you want to override. Required files must be pre-allocated. Application Manager functions, which include run time modules and application definition dialogs, cannot be active during foreground invocation.

Using Mass Installation File Process

To invoke ICQAMRMI from either READY mode or an ISPF session, enter the following on the command line:

```
TSO %ICQAMRMI [MODE(INST|EXP)]
               [BACKUP(Y|N)]
               [AMNAME(application_manager_appl_name)]
               [AMLANG(application_manager_appl_language)]
               [STMALIB(system_administrator_library_name)]
```

ICQAMRMI Parameters (Foreground and Batch)

The invocation parameters to ICQAMRMI are described below. A value that is underlined represents the default value of the keyword.

MODE(INST | EXP)

specifies the mode of operation. The functions of the allowable values, INST and EXP, are:

INST

performs mass processing of installation files with or without upgrade files.

EXP

performs the mass export process.

The default value is INST. If you specify MODE with no value, or if you specify a value that is not allowed, processing terminates.

BACKUP(Y | N)

specifies whether backup copies are to be made of applications that are replaced. The functions of the allowable values, Y and N, are:

Y The tables that are to be modified are exported to the backup installation file, ICQBACK, before they are updated.

N Backup installation files of the tables to be updated are not created.

If you specify BACKUP with no value or if you specify a value that is not allowed, processing terminates.

Specifying BACKUP(Y) causes additional overhead in processing because an additional export is performed for each application that is replaced. However, specifying BACKUP(Y) allows you to restore the original application, if necessary.

The following parameters identify the application definition that contains the control information for the Application Manager function. The mass installation file process must extract this information. If the following three parameters do not uniquely define the Application Manager application, processing may be unsuccessful.

AMNAME(application_manager_appl_name | ICQAPPLMGR)

specifies the name of the Application Manager application. AMNAME and AMLANG keywords are used to uniquely specify the application in the library defined by the STMALIB keyword. In addition, the library allocated to STMALIB contains the look-up table.

The default name is based on the name of the application at the time of the product's installation, ICQAPPLMGR. If you specify the name of a non-existent application, processing terminates.

AMLANG(application_manager_appl_language | ENGLISH)

specifies the language of the Application Manager application.

If you specify a value that does not represent a valid application language, the Application Manager application is not allocated and processing terminates.

The default language is English.

STMALIB(*application_administrator_library_name* | **ICQAMTAB**)

specifies the ddname of the system administrator library. STMALIB applies only to foreground invocation. This library is used to access the information in the look-up table and in the Application Manager application. The library must be allocated before it can be used.

If you are running interactive (foreground) and you want to process table data sets other than the defaults, you should allocate another file and override STMALIB.

The default ddname is ICQAMTAB.

Installation Example for Mass Installation File Processing

This section contains an example of the coding that you must install to use the mass installation file process. The example is divided into two parts as follows:

- A sample of the JCL PROC ICQMIFP (provided in SYS1.SAMPLIB) that contains the default specifications and invokes the mass installation file process
- A sample of the JCL that is required when you want to invoke the sample procedure ICQMIFP and override the default value of the MODE parameter so it will invoke the mass export process.

Note: This is not meant to be a production example.

ICQMIFP Sample

The cataloged JCL PROC ICQMIFP contains the default specifications and invokes the exec ICQAMRMI. A sample of ICQMIFP is as follows in "Sample ICQMIFP PROC."

Sample ICQMIFP PROC

```
/** NAME:          ICQMIFP - MASS INSTALLATION FILE PROCESSING
/** COPYRIGHT:    5645-001
/**              (C) COPYRIGHT IBM CORP. 1989
/**              LICENSED MATERIALS - PROPERTY OF IBM
/**              REFER TO COPYRIGHT INSTRUCTIONS
/**              FORM NUMBER G120-2083
/**
/** THIS SAMPLE PROCEDURE MAY BE MODIFIED AND SAVED IN THE
/** PROCLIB DATA SET. IT MAY BE USED TO INVOKE MASS INSTALLATION
/** OR EXPORT FILE PROCESSING.
/**
/** PARAMETERS:
/**
/** MODE='MODE(INST) '- SIGNAL FOR UPGRADE AND INSTALL (DEFAULT VALUE)
/** MODE='MODE(EXP) '- SIGNAL FOR MASS EXPORT
/**
/** BACKUP='BACKUP(Y) '- SIGNAL AUTOMATIC BACKUPS (DEFAULT VALUE)
/** BACKUP='BACKUP(N) '- SIGNAL NO AUTOMATIC BACKUPS
/**
/** AMNAME='AMNAME() '- APPLICATION MANAGER APPLICATION NAME
/**              (DEFAULT VALUE - ICQAPPLMGR)
/** AMLANG='AMLANG() '- APPLICATION MANAGER APPLICATION LANGUAGE
/**              (DEFAULT VALUE - ENGLISH)
/**
/** ICQUAL='ICQ' - FIRST-LEVEL QUALIFIER FOR THE APPLICATION
/**              MANAGER DATA SETS.
```

Installation Example for Mass Installation

```
/** CONTROL='MASS' - SECOND QUALIFIER FOR THE INPUT AND OUTPUT
/** DATA SETS REQUIRED FOR MASS PROCESSING
/** ISPLVL='V2R3' - FIRST QUALIFIER FOR THE ISPF/PDF DATA SETS
/** ISRLVL='V2R3' - FIRST QUALIFIER FOR THE ISPF DATA SETS
/**
//ICQMIFP PROC MODE='MODE(INST)',
//  BACKUP='BACKUP(Y)',
//  AMNAME='AMNAME(ICQAPPLMGR)',
//  AMLANG='AMLANG(ENGLISH)',
//  ICQUAL='ICQ',
//  CONTROL='MASS',
//  ISPLVL='V2R3',
//  ISRLVL='V2R3'
//ICQMASS EXEC PGM=IKJEFT01,REGION=4096K,SYNAMNBR=40,
// PARM='%ICQAMRMI &MODE &BACKUP &AMNAME &AMLANG'
/**
/**
/**----- INSTALLATION DATASETS -----**
/**
/** INPUT INSTALLATION LIBRARY
//ICQINST DD DSN=&ICQUAL..&CONTROL..INPUT,DISP=SHR
/**
/** OUTPUT INSTALLATION LIBRARY
//ICQOUT DD DSN=&ICQUAL..&CONTROL..OUTPUT,DISP=OLD
/**
/** BACKUP INSTALLATION LIBRARY
//ICQBACK DD DSN=&ICQUAL..&CONTROL..BACKUP,DISP=OLD
/**
/**
/**----- UPGRADE DATASETS -----**
/**
/** UPGRADE LIBRARY
//ICQUPGR DD DSN=&ICQUAL..&CONTROL..UPGRADE,DISP=SHR
/**
/**
/**----- MASS EXPORT DATASETS -----**
/**
/** EXPORT CONTROL FILE
//ICQEXPT DD DSN=&ICQUAL..&CONTROL..EXPORT,DISP=SHR
/**
/**
/**----- TABLE DATA SETS TO BE ADMINISTERED -----**
/**
/** ADMINISTRATOR TABLES DATA SET TO BE MASS PROCESSED
//ICQXATAB DD DSN=&ICQUAL..ICQAMTAB,DISP=OLD
/** USER TABLES DATA SET TO BE MASS PROCESSED
//ICQXUTAB DD DSN=&ICQUAL..ICQCMTAB,DISP=OLD
/**
/**
/**----- APPLICATION MANAGER TABLES DATA SET -----**
/**
/** SYSTEM LEVEL ADMINISTRATOR TABLES DATA SET, REFERENCE
//ICQAMTAB DD DSN=&ICQUAL..ICQAMTAB,DISP=SHR
/**
/**----- CLIST DATA SETS -----**
/**
//SYSPROC DD DSN=&ICQUAL..ICQCCLIB.CLIST,DISP=SHR
//          DD DSN=&ISPLVL..ISPALIB,DISP=SHR
//          DD DSN=&ISRLVL..ISRCLIB,DISP=SHR
/**
/**----- ISPF DATA BASE DATA SETS -----**
/**
//ISPPLIB DD DSN=&ICQUAL..ICQPLIB,DISP=SHR
//          DD DSN=&ISPLVL..ISPPLIB,DISP=SHR
//          DD DSN=&ISRLVL..ISRPLIB,DISP=SHR
//ISPMLIB DD DSN=&ICQUAL..ICQMLIB,DISP=SHR
//          DD DSN=&ISRLVL..ISPMLIB,DISP=SHR
```

Installation Example for Mass Installation

```
//          DD DSN=&ISPLVL..ISRMLIB,DISP=SHR
//ISPTLIB  DD DSN=&ICQUAL..ICQTLIB,DISP=SHR
//          DD DSN=&ISRLVL..ISPTLIB,DISP=SHR
//          DD DSN=&ISPLVL..ISRTLIB,DISP=SHR
//ISPSLIB  DD DSN=&ICQUAL..ICQSLIB,DISP=SHR
//          DD DSN=&ISRLVL..ISPSLIB,DISP=SHR
//          DD DSN=&ISPLVL..ISRSLIB,DISP=SHR
//*
/*----- ISPF TEMPORARY DATA SETS -----**
/*
//ISPCTL1  DD DISP=NEW,UNIT=SYSVIO,SPACE=(CYL,(1,1)),
//          DCB=(LRECL=80,BLKSIZE=800,RECFM=FB,BUFNO=5)
//ISPCTL2  DD DISP=NEW,UNIT=SYSVIO,SPACE=(CYL,(1,1)),
//          DCB=(LRECL=80,BLKSIZE=800,RECFM=FB,BUFNO=5)
//ISPLST1  DD DISP=NEW,UNIT=SYSVIO,SPACE=(CYL,(1,1)),
//          DCB=(LRECL=121,BLKSIZE=1210,RECFM=FBA,BUFNO=5)
//ISPLST2  DD DISP=NEW,UNIT=SYSVIO,SPACE=(CYL,(1,1)),
//          DCB=(LRECL=121,BLKSIZE=1210,RECFM=FBA,BUFNO=5)
//*
/*----- DUMMY ISPF PROFILE DATASET -----**
/*
//ISPPROF  DD DSN=&&ISPPROF,
//          DCB=(LRECL=80,BLKSIZE=3120,RECFM=FB).
//          SPACE=(TRK,(2,2,3)),UNIT=SYSDA,
//          DISP=(NEW,DELETE,DELETE)
//*
//SYSTSPRT DD SYSOUT=*
//SYSTSIN  DD DUMMY
//SYSPRINT DD DD SYSOUT=*
```

Installation Written JCL Override Sample for Mass Export

Figure 89 on page 158 is a sample of installation written JCL to execute the JCL PROC ICQMIFP and override the default value of the MODE parameter so it will perform a mass export.

Installation Example for Mass Installation

```
//USERID0 JOB 'ACCOUNT=999',MSGLEVEL=1,
//          NOTIFY=USERID0,MSGCLASS=H
//*
/* This example overrides the cataloged procedure (ICQMIFP) so
/* that it will perform a mass export.
/*
//EXECRMI EXEC ICQMIFP,
//          MODE='MODE(EXP)'          MASS INSTALLATION
//*
/*
//ICQINST DD DUMMY
//*
/*
/**----- DUMMY OUT UPGRADE DATASET FOR MASS EXPORT -----**
/*
//ICQUPGR DD DUMMY
//*
/*
/**----- OVERRIDE EXPORT DATASET (OPTIONAL OVERRIDE) -----**
/*
//ICQEXPT DD DSN=ICQ.EXPORT.LIST,DISP=SHR
//*
/*
/**----- DON'T OVERRIDE APPLICATION TABLES (OPTIONAL OVERRIDE) ---**
/*
/**ICQXATAB DD DSN=ICQ.OTHER.ICQAMTAB,DISP=SHR          **
/**ICQXUTAB DD DSN=ICQ.OTHER.ICQCMTAB,DISP=SHR          **
/*
/**----- OVERRIDE MESSAGE OUTPUT DESTINATION (OPTIONAL OVERRIDE)--**
/* (OUTPUT TO SEQUENTIAL DATASET INSTEAD OF JCL OUTPUT LISTING) **
/*
//SYSPRINT DD DSN=ICQ.BATCH.MSGOUT,DISP=SHR
/*
```

Figure 89. Sample JCL Override for Mass Export

Part 4. Appendixes

Appendix. Accessibility

Accessible publications for this product are offered through the z/OS Information Center, which is available at www.ibm.com/systems/z/os/zos/bkserv/.

If you experience difficulty with the accessibility of any z/OS information, please send a detailed message to mhvrcfs@us.ibm.com or to the following mailing address:

IBM Corporation
Attention: MHVRCFS Reader Comments
Department H6MA, Building 707
2455 South Road
Poughkeepsie, NY 12601-5400
USA

Accessibility features

Accessibility features help a user who has a physical disability, such as restricted mobility or limited vision, to use software products successfully. The major accessibility features in z/OS enable users to:

- Use assistive technologies such as screen readers and screen magnifier software
- Operate specific or equivalent features using only the keyboard
- Customize display attributes such as color, contrast, and font size.

Using assistive technologies

Assistive technology products, such as screen readers, function with the user interfaces found in z/OS. Consult the assistive technology documentation for specific information when using such products to access z/OS interfaces.

Keyboard navigation of the user interface

Users can access z/OS user interfaces using TSO/E or ISPF. Refer to *z/OS TSO/E Primer*, *z/OS TSO/E User's Guide*, and *z/OS ISPF User's Guide Vol I* for information about accessing TSO/E and ISPF interfaces. These guides describe how to use TSO/E and ISPF, including the use of keyboard shortcuts or function keys (PF keys). Each guide includes the default settings for the PF keys and explains how to modify their functions.

Dotted decimal syntax diagrams

Syntax diagrams are provided in dotted decimal format for users accessing the z/OS Information Center using a screen reader. In dotted decimal format, each syntax element is written on a separate line. If two or more syntax elements are always present together (or always absent together), they can appear on the same line, because they can be considered as a single compound syntax element.

Each line starts with a dotted decimal number; for example, 3 or 3.1 or 3.1.1. To hear these numbers correctly, make sure that your screen reader is set to read out punctuation. All the syntax elements that have the same dotted decimal number (for example, all the syntax elements that have the number 3.1) are mutually

exclusive alternatives. If you hear the lines 3.1 USERID and 3.1 SYSTEMID, you know that your syntax can include either USERID or SYSTEMID, but not both.

The dotted decimal numbering level denotes the level of nesting. For example, if a syntax element with dotted decimal number 3 is followed by a series of syntax elements with dotted decimal number 3.1, all the syntax elements numbered 3.1 are subordinate to the syntax element numbered 3.

Certain words and symbols are used next to the dotted decimal numbers to add information about the syntax elements. Occasionally, these words and symbols might occur at the beginning of the element itself. For ease of identification, if the word or symbol is a part of the syntax element, it is preceded by the backslash (\) character. The * symbol can be used next to a dotted decimal number to indicate that the syntax element repeats. For example, syntax element *FILE with dotted decimal number 3 is given the format 3 * FILE. Format 3* FILE indicates that syntax element FILE repeats. Format 3* * FILE indicates that syntax element * FILE repeats.

Characters such as commas, which are used to separate a string of syntax elements, are shown in the syntax just before the items they separate. These characters can appear on the same line as each item, or on a separate line with the same dotted decimal number as the relevant items. The line can also show another symbol giving information about the syntax elements. For example, the lines 5.1*, 5.1 LASTRUN, and 5.1 DELETE mean that if you use more than one of the LASTRUN and DELETE syntax elements, the elements must be separated by a comma. If no separator is given, assume that you use a blank to separate each syntax element.

If a syntax element is preceded by the % symbol, this indicates a reference that is defined elsewhere. The string following the % symbol is the name of a syntax fragment rather than a literal. For example, the line 2.1 %OP1 means that you should refer to separate syntax fragment OP1.

The following words and symbols are used next to the dotted decimal numbers:

- ? means an optional syntax element. A dotted decimal number followed by the ? symbol indicates that all the syntax elements with a corresponding dotted decimal number, and any subordinate syntax elements, are optional. If there is only one syntax element with a dotted decimal number, the ? symbol is displayed on the same line as the syntax element, (for example 5? NOTIFY). If there is more than one syntax element with a dotted decimal number, the ? symbol is displayed on a line by itself, followed by the syntax elements that are optional. For example, if you hear the lines 5 ?, 5 NOTIFY, and 5 UPDATE, you know that syntax elements NOTIFY and UPDATE are optional; that is, you can choose one or none of them. The ? symbol is equivalent to a bypass line in a railroad diagram.
- ! means a default syntax element. A dotted decimal number followed by the ! symbol and a syntax element indicates that the syntax element is the default option for all syntax elements that share the same dotted decimal number. Only one of the syntax elements that share the same dotted decimal number can specify a ! symbol. For example, if you hear the lines 2? FILE, 2.1! (KEEP), and 2.1 (DELETE), you know that (KEEP) is the default option for the FILE keyword. In this example, if you include the FILE keyword but do not specify an option, default option KEEP will be applied. A default option also applies to the next higher dotted decimal number. In this example, if the FILE keyword is omitted, default FILE(KEEP) is used. However, if you hear the lines 2? FILE, 2.1, 2.1.1!

(KEEP), and 2.1.1 (DELETE), the default option KEEP only applies to the next higher dotted decimal number, 2.1 (which does not have an associated keyword), and does not apply to 2? FILE. Nothing is used if the keyword FILE is omitted.

- * means a syntax element that can be repeated 0 or more times. A dotted decimal number followed by the * symbol indicates that this syntax element can be used zero or more times; that is, it is optional and can be repeated. For example, if you hear the line 5.1* data area, you know that you can include one data area, more than one data area, or no data area. If you hear the lines 3*, 3 HOST, and 3 STATE, you know that you can include HOST, STATE, both together, or nothing.

Note:

1. If a dotted decimal number has an asterisk (*) next to it and there is only one item with that dotted decimal number, you can repeat that same item more than once.
 2. If a dotted decimal number has an asterisk next to it and several items have that dotted decimal number, you can use more than one item from the list, but you cannot use the items more than once each. In the previous example, you could write HOST STATE, but you could not write HOST HOST.
 3. The * symbol is equivalent to a loop-back line in a railroad syntax diagram.
- + means a syntax element that must be included one or more times. A dotted decimal number followed by the + symbol indicates that this syntax element must be included one or more times; that is, it must be included at least once and can be repeated. For example, if you hear the line 6.1+ data area, you must include at least one data area. If you hear the lines 2+, 2 HOST, and 2 STATE, you know that you must include HOST, STATE, or both. Similar to the * symbol, the + symbol can only repeat a particular item if it is the only item with that dotted decimal number. The + symbol, like the * symbol, is equivalent to a loop-back line in a railroad syntax diagram.

Notices

This information was developed for products and services offered in the U.S.A. or elsewhere.

IBM may not offer the products, services, or features discussed in this document in other countries. Consult your local IBM representative for information on the products and services currently available in your area. Any reference to an IBM product, program, or service is not intended to state or imply that only that IBM product, program, or service may be used. Any functionally equivalent product, program, or service that does not infringe any IBM intellectual property right may be used instead. However, it is the user's responsibility to evaluate and verify the operation of any non-IBM product, program, or service.

IBM may have patents or pending patent applications covering subject matter described in this document. The furnishing of this document does not give you any license to these patents. You can send license inquiries, in writing, to:

IBM Director of Licensing
IBM Corporation
North Castle Drive
Armonk, NY 10504-1785
U.S.A

For license inquiries regarding double-byte character set (DBCS) information, contact the IBM Intellectual Property Department in your country or send inquiries, in writing, to:

Intellectual Property Licensing
Legal and Intellectual Property Law
IBM Japan, Ltd.
19-21, Nihonbashi-Hakozakicho, Chuo-ku
Tokyo 103-8510, Japan

The following paragraph does not apply to the United Kingdom or any other country where such provisions are inconsistent with local law: INTERNATIONAL BUSINESS MACHINES CORPORATION PROVIDES THIS PUBLICATION "AS IS" WITHOUT WARRANTY OF ANY KIND, EITHER EXPRESS OR IMPLIED, INCLUDING, BUT NOT LIMITED TO, THE IMPLIED WARRANTIES OF NON-INFRINGEMENT, MERCHANTABILITY OR FITNESS FOR A PARTICULAR PURPOSE. Some states do not allow disclaimer of express or implied warranties in certain transactions, therefore, this statement may not apply to you.

This information could include technical inaccuracies or typographical errors. Changes are periodically made to the information herein; these changes will be incorporated in new editions of the publication. IBM may make improvements and/or changes in the product(s) and/or the program(s) described in this publication at any time without notice.

Any references in this information to non-IBM Web sites are provided for convenience only and do not in any manner serve as an endorsement of those Web sites. The materials at those Web sites are not part of the materials for this IBM product and use of those Web sites is at your own risk.

Notices

IBM may use or distribute any of the information you supply in any way it believes appropriate without incurring any obligation to you.

Licenses of this program who wish to have information about it for the purpose of enabling: (i) the exchange of information between independently created programs and other programs (including this one) and (ii) the mutual use of the information which has been exchanged, should contact:

Site Counsel
IBM Corporation
2455 South Road
Poughkeepsie, NY 12601-5400
USA

Such information may be available, subject to appropriate terms and conditions, including in some cases, payment of a fee.

The licensed program described in this information and all licensed material available for it are provided by IBM under terms of the IBM Customer Agreement, IBM International Program License Agreement, or any equivalent agreement between us.

Information concerning non-IBM products was obtained from the suppliers of those products, their published announcements or other publicly available sources. IBM has not tested those products and cannot confirm the accuracy of performance, compatibility or any other claims related to non-IBM products. Questions on the capabilities of non-IBM products should be addressed to the suppliers of those products.

All statements regarding IBM's future direction or intent are subject to change or withdrawal without notice, and represent goals and objectives only.

If you are viewing this information softcopy, the photographs and color illustrations may not appear.

COPYRIGHT LICENSE:

This information might contain sample application programs in source language, which illustrate programming techniques on various operating platforms. You may copy, modify, and distribute these sample programs in any form without payment to IBM, for the purposes of developing, using, marketing or distributing application programs conforming to the application programming interface for the operating platform for which the sample programs are written. These examples have not been thoroughly tested under all conditions. IBM, therefore, cannot guarantee or imply reliability, serviceability, or function of these programs. The sample programs are provided "AS IS", without warranty of any kind. IBM shall not be liable for any damages arising out of your use of the sample programs.

Policy for unsupported hardware

Various z/OS elements, such as DFSMS, HCD, JES2, JES3, and MVS, contain code that supports specific hardware servers or devices. In some cases, this device-related element support remains in the product even after the hardware devices pass their announced End of Service date. z/OS may continue to service element code; however, it will not provide service related to unsupported hardware devices. Software problems related to these devices will not be accepted

for service, and current service activity will cease if a problem is determined to be associated with out-of-support devices. In such cases, fixes will not be issued.

Minimum supported hardware

The minimum supported hardware for z/OS releases identified in z/OS announcements can subsequently change when service for particular servers or devices is withdrawn. Likewise, the levels of other software products supported on a particular release of z/OS are subject to the service support lifecycle of those products. Therefore, z/OS and its product publications (for example, panels, samples, messages, and product documentation) can include references to hardware and software that is no longer supported.

- For information about software support lifecycle, see: IBM Lifecycle Support for z/OS (<http://www.ibm.com/software/support/systemsz/lifecycle/>)
- For information about currently-supported IBM hardware, contact your IBM representative.

Trademarks

IBM, the IBM logo, and [ibm.com](http://www.ibm.com) are trademarks or registered trademarks of International Business Machines Corp., registered in many jurisdictions worldwide. Other product and service names might be trademarks of IBM or other companies. A current list of IBM trademarks is available on the Web at "Copyright and trademark information" at www.ibm.com/legal/copytrade.shtml (<http://www.ibm.com/legal/copytrade.shtml>).

Index

Special characters

> 108

+ 108

A

abstracts for courses, maintaining 44
accessibility 161
 contact IBM 161
 features 161
ACCOUNT command 15
account number
 adding 21
 changing 23
 deleting 25
 for charging computer time 59
 listing 18
ADD operation, in upgrade file 137
ADD subcommand of ACCOUNT 21
ADDUSER command
 parameters 3
ADMIN command 7
administration defaults, modifying 53,
 60, 75
administrator, IIPS, invoking IIPS as 53
administrator's profile 75
alias
 user catalog 3, 63, 71
allocation, OLD specification 120, 126
allocation, SHR specification 120, 126
ALTLIB command 120, 126
AMLANG keyword 154
AMNAME keyword 154
AMSELECT command 7
APPC/MVS administration dialog
 Application Manager, using 8
 defining components 7
 description 7
APPC/MVS information
 administering 7
Application Commands panel 121
Application Libraries panel 119, 125
Application Manager
 APPC/MVS administration dialog,
 installing 8
Application Manager – Add an
 Application panel 114, 116, 122, 130
Application Manager – Define a Function
 panel 115, 123
Application Manager – Define a Panel
 panel 130
Application Manager – Define an
 Environment panel 116
Application Manager – Export an
 Application panel 134
Application Manager – Installation File
 panel 114
Application Manager – List of
 Applications panel 108, 116, 122, 129,
 133

Application Manager – Upgrade
 Installation File panel 140
Application Manager – Where Used
 List 144
Application Manager dialogs,
 invoking 105
Application Manager, valid operations for
 levels 104
Application Matching Keyword panel,
 reference to 104
application search order 103
application selection time 103
applications
 adding with an installation file 111
 authority requirements to
 administer 104
 automatic integration on panels 112
 copying 103, 142
 creating an installation file
 (example) 133
 define at specific levels, how to 105
 deleting 142
 description of 101
 discarding new 142
 displaying the hierarchy of 109
 displaying the list of 107
 environment
 adding without an installation
 file 116
 defining libraries for 118
 information sheet for 145
 exporting an 133
 function
 adding without an installation
 file 122
 defining libraries for 124
 information sheet for 146
 installation file (example) 111
 invocation error, reasons for 104
 levels of 101
 mass installation process 149
 modifying 143
 panel
 adding without an installation
 file 129
 displaying hierarchy for 109
 information sheets for 147
 replacing 117, 144
 required specifications to add 111
 saving new 142
 search order to invoke 103
 seeing where used 144
 testing 143
 upgrading an 135
 viewing 108
APPLMGR option 105
assistive technologies 161
asterisk (*)
 use in ACCOUNT command 19
 use in enroll 56
 use in print definitions 30, 46, 82

asterisk (*) (*continued*)
 use in specifying GROUP ID 106
 use in upgrade file 136
 use in user type 64
author IDs for IIPS courses, changing the
 default for 53
authority requirements with RACF 104
authorization parameters
 on RACF commands 69
 on the TSO/E ACCOUNT ADD
 command 67
automatic integration, application on
 panel 112

B

backup libraries 150
batch terminal monitor program 149

C

CANCEL command 7, 68
catalog
 master 63, 71
 user 3, 63, 71
CHANGE subcommand of
 ACCOUNT 23
changing system default ISPF profile 60,
 75
class-authority classes 70
CLIST library 120, 126
commands 63
 ACCOUNT
 ADD subcommand 21
 CHANGE subcommand 23
 DELETE subcommand 25
 HELP subcommand 18
 LIST and LISTIDS
 subcommands 18
 using subcommands 17
 ADMIN 7
 AMSELECT 7
 CANCEL 7, 68
 EDIT 68
 GO 7
 IC 7
 KEYS 6
 NEW 7
 OPERATOR 68
 OUTPUT 68
 RACF
 ADDUSER TSO 12
 ALTUSER NOTSO 12
 ALTUSER TSO 12
 LISTUSER TSO 12
 STATUS 68
 SUBMIT 68
 VSAM DEFINE ALIAS 63
conditions for courses, maintaining 44

- courses
 - abstracts, maintaining 44
 - adding 46
 - administration defaults,
 - modifying 53
 - conditions for courses,
 - maintaining 44
 - conditions not displayed, changing
 - the default 53
 - defaults, modifying 53
 - deleting 48
 - displaying a list of courses 45
 - modifying 47
 - names of courses, maintaining 44
 - printing of 45, 80
 - registration lists, updating 51
 - registration requests, processing 48
 - requests for registration,
 - processing 48
 - viewing an abstract 45
- COURSES option 4
- creating options on panels 112
- customizations, use of upgrade file
 - on 135
- customize user's profile 60

D

- data base token 8
- data base, RACF
 - ADDUSER command
 - function of 12
- data set
 - for library types 118, 124
 - routing 67
 - specifying location of 67
 - specifying output class for 67
 - SYS1.UADS 63, 67
- data set, IIPS, changing the high-level
 - qualifier for 53
- DBCS (double-byte character set)
 - characters 118
- ddname for libraries 120, 126, 154
- defaults for courses, modifying 53
- Define a Function – General Information
 - panel 123
- Define a Panel – Options panel 132
- DEFINE ALIAS command
 - function of 63
 - parameters 3, 70
- Define an Environment – General
 - Information panel 117
- defining libraries
 - for environments 119
 - for functions 125
 - invocation considerations 120, 126
- DELETE operation, in upgrade file 138
- DELETE subcommand of ACCOUNT 25

E

- EDIT command 68
- edit macro
 - errors, when in 139
 - performance for ADD entry in
 - upgrade 137

- edit macro (*continued*)
 - performance for DELETE entry in
 - upgrade 138
 - performance for REPLACE entry in
 - upgrade 137
- education services
 - abstracts, maintaining 44
 - adding a course 46
 - administration defaults,
 - modifying 53
 - conditions for courses,
 - maintaining 44
 - course conditions not displayed,
 - changing the default 53
 - defaults for courses, modifying 53
 - deleting a course 48
 - displaying a list of courses 45
 - modifying a course 47
 - names of courses, maintaining 44
 - printing an abstract 45
 - registration lists, updating 51
 - registration requests, processing 48
 - requests for registration,
 - processing 48
 - viewing an abstract 45
- Enroll – Add or Modify a User panel 57
- Enroll – Information Center Identification
 - panel 58
- Enroll – List of Users panel 56
- Enroll – User Identification panel 56
- ENROLL option 3
- enroll service
 - cancelling enrollment 62
 - description 55
- environment applications
 - adding with an installation file 111
 - adding without an installation
 - file 116
 - copying 103, 142
 - creating an installation file
 - (export) 133
 - deleting 142
 - description of 101
 - information sheet for 145
 - installation file with library entries
 - (example) 120
 - modifying 143
 - replacing 117, 144
 - seeing where used 144
 - testing 143
 - upgrade file, header section of 136
 - viewing 108
- errors, encountered in upgrade file 139
- EXIT option 5
- EXPORT option 133, 139, 149

F

- function applications
 - adding with an installation file 111
 - adding without an installation
 - file 122
 - copying 103, 142
 - creating an installation file
 - (export) 133
 - deleting 142
 - description of 101

- function applications (*continued*)
 - displaying list 107
 - information sheet for 146
 - installation file (example) 111
 - installation file with library entries
 - (example) 126
 - modifying 143
 - replacing 123
 - seeing where used 144
 - testing 143
 - upgrade file, header section of 136
 - viewing 108
- functions and requirements of TSO/E
 - action characters, List of Applications
 - panel 108
 - Application Manager definitions,
 - levels of
 - group administration level 101
 - private administration level 101
 - system administration level 101
 - valid operations, based on
 - defaults 104
 - authority requirements with RACF
 - installed 104
 - exporting an application 149, 150, 152
 - generating a hierarchy 109
 - invoking Application Manager dialogs
 - at group level 105
 - at private level 107
 - at system level 105
 - invoking List of Applications
 - panel 108
 - INVOKING_PANEL entry 112
 - managing multiple applications
 - application search order to
 - invoke 103
 - applications using other
 - applications 103
 - considerations for 102
 - copying, level to level 103
 - invocation error, reasons for 104
 - mass installation file processing 149
 - printing a course abstract 45
 - printing a news item 30
 - seeing where application is used 144
 - upgrading an application
 - operational entries for
 - (example) 136
 - process to start 139
 - specifying a DELETE
 - operation 138
 - specifying a REPLACE
 - operation 137
 - specifying an ADD operation 137
 - WITH keyword, using 137

G

- generating a hierarchy 109
- GO command 7
- group administrator, as a
 - creating new group to
 - administer 106
 - invoke dialogs, how to 105
 - operations available to perform 106, 143

- group administrator, as a (*continued*)
 - selecting existing group to administer 106
 - to display list of applications 108
- group level applications
 - LEVEL column 108
 - use of 103
 - use of Application Manager dialogs for 105
 - within application hierarchy 110
- group name
 - creating a new 106
 - existing 106
- GROUP option 105
- group user library 103
- GROUPSPEC option 103

H

- header section, upgrade files 136
- HELP subcommand of ACCOUNT 18
- Hierarchy Display
 - application does not exist, depicted 110
 - list exceeds horizontal space, depicted 110
 - to access the option 109
 - unavailable/unverified, applications found 110, 143
- Hierarchy Display, example of 109
- high-level qualifier for IIPS data sets, changing the default for 53

I

- IC command 7
- ICFUSER option 107
- ICQAAE13 57
- ICQADE00 64
- ICQADE02 64
- ICQADE04 65
- ICQADE05 67
- ICQADE06 71
- ICQADE08 68
- ICQADE09 70
- ICQADE10 72
- ICQADE12 70
- ICQADE14 73
- ICQADM16 65
- ICQADM17 72
- ICQAEE10 56
- ICQAEE11 56
- ICQAEE41 58
- ICQAME19 109
- ICQAME88 140
- ICQAMEA2 106
- ICQAMED1 (Programmer Services panel) 105, 107
- ICQAMED1 (System Default panel) 76, 79
- ICQAMRMI parameters 154
- ICQAMTAB 155
- ICQAPE00 77, 79
- ICQAPE10 98
- ICQAPE30 80
- ICQAPE50 84

- ICQAPE51 85
- ICQAPE52 86
- ICQAPE53 89
- ICQAPE54 90
- ICQAPE55 91
- ICQAPE56 92
- ICQAPE57 93
- ICQAPE60 88, 94
- ICQAPE70 95
- ICQAPE80 82
- ICQAPE90 96
- ICQAPE91 97
- ICQAPM20 80
- ICQAPPLMGR 154
- ICQAPROC LOGON procedure 66
- ICQCAE12 57
- ICQCNE30 30, 46
- ICQCPE00 78
- ICQMIFP procedure 153
- ICQSAMP(APROC) LOGON procedure 66
- IDs
 - destination 67
- IIAS (Interactive Instructional Authoring System) 4
- IIPS (Interactive Instructional Presentation System)
 - author IDs, changing the default for 53
 - courses
 - abstracts, maintaining 44
 - adding 46
 - administration defaults, modifying 53
 - conditions for courses, maintaining 44
 - conditions not displayed, changing the default 53
 - defaults, modifying 53
 - deleting 48
 - displaying a list of courses 45
 - modifying 47
 - names of courses, maintaining 44
 - printing an abstract 45
 - registration lists, updating 51
 - registration requests, processing 48
 - requests for registration, processing 48
 - viewing an abstract 45
 - data sets, changing the high-level qualifier for 53
 - invoking 53
 - student IDs, changing the default for 53
- Information Center Facility
 - add a service to 101
 - administrative services 3
 - Application Manager 4, 101
 - application selection time 103
 - courses service 4, 43
 - enroll service 3, 55
 - exiting from 8
 - ISPF default profile 4, 55, 75
 - messages while under 5
 - names service 3, 35
 - news service 3, 29

- Information Center Facility (*continued*)
 - password 59
 - print definitions 4, 77
 - user type service 3, 63
- Information Center Facility – Define User Types panel 64
- Information Center Facility – Group Identification panel 106
- Information Center Facility – Hierarchy Display (example) 109
- Information Center Facility – List of Printers for Administrators panel 77, 79
- Information Center Facility – List of Printers for Users panel 78
- Information Center Facility – Printer Specification panel 30, 46
- Information Center Facility – Programmer Services panel 105, 107
- Information Center Facility – System Defaults panel 76, 79
- Information Center Facility administrator responsibilities of
 - list of 3
- Information Center Facility applications 101
- Information Center Facility/ISPF user profile 55, 63
- information sheets
 - for environments 145
 - for functions 146
 - for panels 147
- initiate upgrade 139
- INPUT library type 118, 124
- installation data in user profiles 70
- installation file
 - adding an application with 111
 - creating an 133
 - mass installation process 149
- installation file for a function (example) 111
- Interactive Instructional Authoring System (IIAS) 4
- Invocation Error panel, reference to 104
- invoking applications
 - at each level, process 105, 112
 - mass installation file process, using ICQAMRMI parameters 154
 - in batch (TMP) 154
 - in foreground 154
 - on existing panels, as options 112
 - search order pertaining to 103
 - unsuccessful, reasons for 104
- INVOKING_PANEL entry 112
- ISPF Edit 139
- ISPF library 120, 126
- ISPF Parameter Options panel
 - categories of defaults, changing 60
 - reference to 60, 75
- ISPF/PDF
 - changing the system default profile 75
 - setting defaults 60, 75
- ISPF/PDF editor, using 6

J

- JES2
 - user ID restrictions 11

K

- keyboard
 - navigation 161
 - PF keys 161
 - shortcut keys 161
- KEYS command 6, 60, 75
- keyword parameters of ACCOUNT subcommands 17
- keywords, INVOKING_PANEL entry 113
- keywords, valid upgrade action for file 141

L

- LEVEL column 107
- LIBDEF command 120, 126
- LIBRARIES option 119, 125
- libraries, allocating 119, 125
- libraries, mass installation use of 150
- library entries, in installation file (example) 120, 126
- library types 118, 124
- LIST and LISTIDS subcommands of ACCOUNT 18
- list data set in user profile 75
- List of Groups panel, reference to 106
- log data sets in user profile 75
- LOGON procedures 66
 - adding 21
 - changing 23
 - default 65
 - deleting 25
 - listing 18

M

- maintaining
 - educational services 4, 43
 - multiple level applications 102
 - the names directory 3, 36
 - the news service 3, 29
 - the system default ISPF profile 4, 60, 75
 - user type definitions 3, 63
- mass installation file processing capabilities 149
 - export service 149
 - input for 151
 - installation example 155
 - libraries, used for 150
 - messages for, receiving 149, 151
 - restrictions 151
 - upgrade and install service 149
- master catalog
 - adding user catalog alias 63
 - specifying name of 71
 - specifying password for 59
- master TRANSMIT/RECEIVE names file, maintaining 42
- model profile
 - for RACF profiles 70
 - ISPFDEF option 55, 60, 75
 - SYSDEF option 55, 60, 75
- multiple computer systems, installations on 149

N

- names directory
 - group entry
 - adding 40
 - deleting 40
 - description of 35
 - finding 38
 - modifying 39
 - viewing 39
 - maintaining 3
 - master TRANSMIT/RECEIVE names file, maintaining 42
 - name entry
 - adding 38
 - deleting 37
 - description of 35
 - finding 36
 - modifying 37
 - viewing 37
 - names file for TRANSMIT/RECEIVE, master, maintaining 42
 - requests to update the master directory, processing 41
- names file for TRANSMIT/RECEIVE, master, maintaining 42
- names of courses, maintaining 44
- NAMES option 3
- navigation
 - keyboard 161
- NEW command 7
- new user's profile
 - customizing the profile 75
 - using system default ISPF profile 75
- NEWS option 3
- news service
 - adding a news item 31
 - deleting a news item 33
 - description of news item 29
 - finding a news item 29
 - maintaining 3
 - modifying a news item 32
 - printing a news item 30
 - viewing a new item of news 31
 - viewing a news item 31
- nodelist 17
- Notices 165

O

- OPERATOR command 68
- operator ID card
 - requiring via user type definitions 69
 - use in enrollment processing 59
- options on panels, creating 112
- output class 66, 67
- OUTPUT command 68
- output installation library 150
- OUTPUT library type 118, 124

P

- panel applications
 - adding with an installation file 111
 - adding without an installation file 129
 - copying 103, 142
 - creating an installation file (export) 133
 - deleting 142
 - description of 101
 - displaying hierarchy for 109
 - displaying the list of 108
 - modifying 143
 - replacing 131
 - seeing where used 144
 - testing 143
 - upgrade file, header section of 136
 - viewing 108
- parameters
 - authorization 67, 69, 70
 - for the TSO/E ACCOUNT command 17, 67
 - for the VSAM DEFINE ALIAS command 70
- password
 - adding 21
 - changing 23
 - deleting 25
 - for accessing TSO/E 59
 - for the master catalog 59
 - listing 18
- PF key definitions, displaying 6
- PF keys
 - settings in user profiles 55, 75
- positional parameters of ACCOUNT subcommands 17
- print definitions
 - accessing 79
 - adding 79
 - copying 79
 - deleting 98
 - description of 77
 - fonts option 95
 - function option 82
 - general PRINTDS parameters 88
 - Identification option 80
 - modifying 79
 - parameter option 84
 - test option 96
- Printer – Delete a Print Definition panel 98
- Printer – General Parameters panel 84, 85, 86
- Printer – General PRINTDS Parameters panel 89
- Printer – Parameters panel 88, 94
- Printer – Print Definition panel 80
- Printer – Print Fonts panel 95
- Printer – Print Function panel 82
- Printer – Print function test results panel 97
- Printer – PRINTDS – 3800 Parameters panel 93
- Printer – PRINTDS – Content Description panel 91, 92
- Printer – PRINTDS – Output Format panel 90

Printer – Printer Identification panel 80
 Printer – Printer Specification panel 30, 46
 Printer – Test the Print Definition panel 96
 printing service
 for course abstracts 45
 for news items 30
 private administrator, as a
 invoke dialogs, how to 107
 operations available to perform 107
 to display list of applications 108
 private level applications
 LEVEL column 108
 use of 103
 use of Application Manager dialogs for 107
 within application hierarchy 110
 PRIVATE option 107
 profile
 RACF 63, 70
 PROGRAM option 105, 107

R

RACF
 adding users 3, 63
 ADDUSER command
 parameters 3
 commands 12
 data base 12
 group 63, 68
 name associated with user ID 59
 requirements to administer applications 104
 RECOVER parameter on the EDIT command 68
 region size of user's private area 66
 registration lists for courses, updating 51
 registration requests, processing 48
 REPLACE operation, in upgrade file 137
 replacing existing applications 144
 requests for registration, processing 48
 required entry, valid operations 141
 reserved output class 66
 restore installation file 141
 REXX exec library 120, 126

S

selection of user ID 11
 sending comments to IBM xv
 setting 60
 ISPF defaults 60
 the system default ISPF profile 75
 sheets, information
 for environments 145
 for functions 146
 for panels 147
 shortcut keys 161
 side information 8
 split screen 75, 102
 STATUS command 68
 STMALIB keyword 154

student IDs for IIPS courses, changing the default for 53
 SUBMIT command 68
 Summary of changes xvii
 Supervisory Call for Dynamic Allocation 120, 126
 syntax of upgrade files 136
 SYS1.SAMPLIB 153
 SYS1.UADS (user attributes data set) 63
 SYSDEF option 4, 55
 SYSEXEC ddname 120, 126
 SYSOUT CLASS field
 for user data sets 67
 SYSPROC ddname 120, 126
 system administrator library, ddname of 155
 system administrator, as a
 invoke dialogs, how to 105
 operations available to perform 105
 to display list of applications 108
 system default ISPF profile
 changing 60, 75
 description of 75
 use in enrollment 4
 user's profile use of 55
 system level applications
 LEVEL column 107
 use of 101, 102
 use of Application Manager dialogs for 105
 within application hierarchy 110
 SYSTSPRT file 149

T

T field (truncate) 118, 124
 terminal characteristics
 contained in user profile 55, 75
 modifying 75
 TEST option 142, 143
 trademarks 167
 transaction program profile 8
 TRANSMIT/RECEIVE names file, master, maintaining 42
 TSO/E administrator
 description of tasks 3
 TSO/E SUBMIT command 153
 TSO/E user
 adding 19
 changing 23
 defining
 ACCOUNT command 13
 ENROLL option 12
 removing 25
 tutorial for Application Manager 102

U

UADS (user attributes data set)
 adding new information to an entry 21
 adding user IDs 19
 changing an entry 23
 deleting entries 25
 help while maintaining 18
 listing information about entries 18

UADS (user attributes data set)
 (continued)
 structure of entries 15
 structure of user definitions 15
 upgrade file
 format of 135
 mass installation of 149
 message lines 140
 notes lines 140
 Upgrade File Specification panel, reference to 139
 UPGRADE option 135
 upgrade, process to perform 139
 user
 defining to TSO/E
 converting to the RACF data base 13
 ways to define
 ACCOUNT command 13
 ENROLL option 12
 RACF commands 12
 user catalog alias 3, 63, 71
 user ID
 adding 19
 adding new information to 21
 changing information for 23
 deleting 25
 help while maintaining 18
 listing 18
 naming conventions 11
 restrictions for JES2 installations 11
 user ID selection 11
 user interface
 ISPF 161
 TSO/E 161
 user type
 adding 71
 definitions
 listing 64
 maintaining 3, 63
 optional RACF information 70
 TSO/E authorization information 67
 TSO/E user ID information 65
 VSAM DEFINE ALIAS parameters 70
 deleting 73
 description of 63
 modifying 72
 viewing 64
 User Types – Delete a User Type panel 73
 User Types – List of User Types panel 64
 User Types – Select Option to Modify panel 72
 User Types – Select User Information panel 65
 User Types – Specify RACF Security Information panel 72
 User Types – Specify TSO/E User ID Information panel 71
 User Types – View Authorization Information panel 67
 User Types – View Optional RACF Information panel 70

- User Types – View RACF Security Information 68
- User Types – View TSO/E User ID Information 65
- User Types – View User Catalog Alias panel 70
- USERTYPE option 3

V

- valid operations for application levels 104
- Variable Definitions panel 117, 124
- variables, truncated 118, 124
- volume mounting 68
- VSAM DEFINE ALIAS command
 - function of 63
 - parameters 3, 70

W

- WITH keyword 137
- worksheet for enroll 61
- worksheet for print definition 98



Product Number: 5650-ZOS

Printed in USA

SA32-0977-00

