



Power Systems  
Backplanes







Power Systems  
Backplanes

**Note**

Before using this information and the product it supports, read the information in “Notices,” on page 89, “Safety notices” on page v, the *IBM Systems Safety Notices* manual, G229-9054, and the *IBM Environmental Notices and User Guide*, Z125-5823.

This edition applies to IBM Power Systems™ servers that contain the POWER6® processor and to all associated models.

© Copyright IBM Corporation 2007, 2009.

US Government Users Restricted Rights – Use, duplication or disclosure restricted by GSA ADP Schedule Contract with IBM Corp.

---

# Contents

<b>Safety notices</b> . . . . .	<b>v</b>
<b>Backplanes</b> . . . . .	<b>1</b>
<b>Chapter 1. Removing the 8234-EMA, 9117-MMA, or 9406-MMA system backplane</b> . . . .	<b>3</b>
Preparing the system . . . . .	3
Removing the system backplane . . . . .	4
<b>Chapter 2. Replacing the 8234-EMA, 9117-MMA, or 9406-MMA system backplane</b> . . . .	<b>7</b>
Replacing the system backplane . . . . .	7
Completing the procedure . . . . .	9
<b>Chapter 3. Removing and replacing the 8203-E4A, 8204-E8A, 8261-E4S, 9407-M15, 9408-M25, or 9409-M50 disk drive backplane</b> . . . . .	<b>13</b>
Removing the 8203-E4A, 8204-E8A, 8261-E4S, 9407-M15, 9408-M25, or 9409-M50 disk drive backplane . . . . .	13
Replacing the 8203-E4A, 8204-E8A, 8261-E4S, 9407-M15, 9408-M25, or 9409-M50 disk drive backplane . . . . .	23
<b>Chapter 4. Removing and replacing the disk drive backplane in the 5802 or 5877 expansion unit</b> . . . . .	<b>33</b>
Removing the disk drive backplane from the 5802 or 5877 expansion unit . . . . .	33
Replacing the disk drive backplane in the 5802 or 5877 expansion unit . . . . .	36
<b>Chapter 5. Common procedures</b> . . . . .	<b>41</b>
Before you begin . . . . .	41
Identifying a failing part . . . . .	43
Identifying a failing part on an AIX system or logical partition . . . . .	43
Locating a failing part on an AIX system or logical partition . . . . .	43
Activating the indicator light for the failing part . . . . .	43
Identifying a failing part on an IBM i system or logical partition . . . . .	44
Activating the failing-part indicator light . . . . .	44
Deactivating the failing-part indicator light . . . . .	44
Identifying a failing part on a Linux system or logical partition . . . . .	45
Locating a failing part on a Linux system or logical partition . . . . .	45
Finding the location code of a failing part in a Linux system or logical partition . . . . .	45
Activating the indicator light for the failing part . . . . .	45
Deactivating the failing-part indicator light . . . . .	45
Locating a failing part in a Virtual I/O Server system or logical partition . . . . .	45
Identifying a part using the Virtual I/O Server . . . . .	46
Starting the system or logical partition . . . . .	46
Starting a system that is not managed by a Hardware Management Console . . . . .	46
Starting a system or logical partition using the Hardware Management Console . . . . .	48
Stopping a system or logical partition . . . . .	48
Stopping a system that is not managed by a Hardware Management Console . . . . .	48
Stopping a system by using the Hardware Management Console . . . . .	50
Disconnecting the SMP processor cable from a system . . . . .	51
Reconnecting the SMP processor cable to a system . . . . .	54
Removing and replacing covers and doors . . . . .	57
Removing the service access cover from a rack-mounted 8203-E4A, 8204-E8A, 8261-E4S, 9407-M15, 9408-M25, or 9409-M50 . . . . .	57
Installing the service access cover on a rack-mounted 8203-E4A, 8204-E8A, 8261-E4S, 9407-M15, 9408-M25, or 9409-M50 . . . . .	58
Removing the service access cover from a stand-alone 8203-E4A, 8204-E8A, 8261-E4S, 9407-M15, 9408-M25, or 9409-M50 . . . . .	59

Installing the service access cover on a stand-alone 8203-E4A, 8204-E8A, 8261-E4S, 9407-M15, 9408-M25, or 9409-M50 . . . . .	60
Removing the front cover from a rack-mounted 8203-E4A, 8204-E8A, 8261-E4S, 9407-M15, 9408-M25, or 9409-M50 . . . . .	61
Installing the front cover on a rack-mounted 8203-E4A, 8204-E8A, 8261-E4S, 9407-M15, 9408-M25, or 9409-M50 . . . . .	62
Removing the door from the 8204-E8A or 9409-M50 . . . . .	63
Installing or replacing the door on the 8204-E8A or 9409-M50 . . . . .	63
Removing the front cover from the stand-alone 8203-E4A, 8204-E8A, 8261-E4S, 9407-M15, 9408-M25, or 9409-M50 . . . . .	63
Installing the front cover on a stand-alone 8203-E4A, 8204-E8A, 8261-E4S, 9407-M15, 9408-M25, or 9409-M50 . . . . .	64
Removing and replacing the front cover for the 8234-EMA, 9117-MMA, or 9406-MMA . . . . .	65
Removing the front cover from the 8234-EMA, 9117-MMA, or 9406-MMA . . . . .	65
Installing the front cover on the 8234-EMA, 9117-MMA, or 9406-MMA . . . . .	66
Placing the rack-mounted system or expansion unit in the service position or operating position . . . . .	67
Placing the rack-mounted system or expansion unit in the service position . . . . .	67
Placing the rack-mounted system or expansion unit in the operating position . . . . .	71
Placing a rack-mounted 8203-E4A, 8204-E8A, 8261-E4S, 9407-M15, 9408-M25, or 9409-M50 in the service position . . . . .	72
Placing the rack-mounted 8203-E4A, 8204-E8A, 8261-E4S, 9407-M15, 9408-M25, or 9409-M50 in the operating position . . . . .	75
Exchanging a part using the Hardware Management Console . . . . .	77
Hardware service manager Verify option . . . . .	77
Verifying an installed feature or replaced part on an AIX system or logical partition . . . . .	78
Verifying an installed part on an IBM i system or logical partition . . . . .	80
Deactivating the failing-part indicator light . . . . .	81
Verifying the installed part on a Linux system or logical partition . . . . .	81
Verifying an installed part using stand-alone diagnostics . . . . .	81
Verifying an installed part using Hardware Management Console . . . . .	82
Activating and deactivating LEDs . . . . .	83
Deactivating a system attention LED or partition LED . . . . .	83
Activating or deactivating identify LED . . . . .	83
Viewing serviceable events . . . . .	84
Verifying an installed feature or replaced part on a system or logical partition using Virtual I/O Server tools . . . . .	85
<b>Appendix. Notices . . . . .</b>	<b>89</b>
Trademarks . . . . .	90
Electronic emission notices . . . . .	90
Class A Notices . . . . .	90
Terms and conditions . . . . .	94

---

## Safety notices

Safety notices may be printed throughout this guide:

- **DANGER** notices call attention to a situation that is potentially lethal or extremely hazardous to people.
- **CAUTION** notices call attention to a situation that is potentially hazardous to people because of some existing condition.
- **Attention** notices call attention to the possibility of damage to a program, device, system, or data.

### World Trade safety information

Several countries require the safety information contained in product publications to be presented in their national languages. If this requirement applies to your country, a safety information booklet is included in the publications package shipped with the product. The booklet contains the safety information in your national language with references to the U.S. English source. Before using a U.S. English publication to install, operate, or service this product, you must first become familiar with the related safety information in the booklet. You should also refer to the booklet any time you do not clearly understand any safety information in the U.S. English publications.

### German safety information

Das Produkt ist nicht für den Einsatz an Bildschirmarbeitsplätzen im Sinne § 2 der Bildschirmarbeitsverordnung geeignet.

### Laser safety information

IBM® servers can use I/O cards or features that are fiber-optic based and that utilize lasers or LEDs.

#### Laser compliance

All lasers are certified in the U.S. to conform to the requirements of DHHS 21 CFR Subchapter J for class 1 laser products. Outside the U.S., they are certified to be in compliance with IEC 60825 as a class 1 laser product. Consult the label on each part for laser certification numbers and approval information.

#### CAUTION:

**This product might contain one or more of the following devices: CD-ROM drive, DVD-ROM drive, DVD-RAM drive, or laser module, which are Class 1 laser products. Note the following information:**

- **Do not remove the covers. Removing the covers of the laser product could result in exposure to hazardous laser radiation. There are no serviceable parts inside the device.**
- **Use of the controls or adjustments or performance of procedures other than those specified herein might result in hazardous radiation exposure.**

(C026)

#### CAUTION:

**Data processing environments can contain equipment transmitting on system links with laser modules that operate at greater than Class 1 power levels. For this reason, never look into the end of an optical fiber cable or open receptacle. (C027)**

#### CAUTION:

**This product contains a Class 1M laser. Do not view directly with optical instruments. (C028)**

**CAUTION:**

Some laser products contain an embedded Class 3A or Class 3B laser diode. Note the following information: laser radiation when open. Do not stare into the beam, do not view directly with optical instruments, and avoid direct exposure to the beam. (C030)

**Power and cabling information for NEBS (Network Equipment-Building System) GR-1089-CORE**

The following comments apply to the IBM servers that have been designated as conforming to NEBS (Network Equipment-Building System) GR-1089-CORE:

The equipment is suitable for installation in the following:

- Network telecommunications facilities
- Locations where the NEC (National Electrical Code) applies

The intrabuilding ports of this equipment are suitable for connection to intrabuilding or unexposed wiring or cabling only. The intrabuilding ports of this equipment *must not* be metallically connected to the interfaces that connect to the OSP (outside plant) or its wiring. These interfaces are designed for use as intrabuilding interfaces only (Type 2 or Type 4 ports as described in GR-1089-CORE) and require isolation from the exposed OSP cabling. The addition of primary protectors is not sufficient protection to connect these interfaces metallically to OSP wiring.

**Note:** All Ethernet cables must be shielded and grounded at both ends.

The ac-powered system does not require the use of an external surge protection device (SPD).

The dc-powered system employs an isolated DC return (DC-I) design. The DC battery return terminal *shall not* be connected to the chassis or frame ground.

---

## **Backplanes**

Learn about removing, replacing, or installing a system backplane in the server.



---

# Chapter 1. Removing the 8234-EMA, 9117-MMA, or 9406-MMA system backplane

Learn about removing the system backplane from the server.

## Related information

 Model 8234-EMA, 9117-MMA, or 9406-MMA control panel

 Voltage regulators

---

## Preparing the system

If you have a SCSI disk enclosure attached to the system, you might want to disconnect the SCSI cable at the enclosure to prevent a potential SCSI address conflict on the attached enclosure when you power off the system.

To prepare the system for removing the system backplane, complete the following steps:

1. Perform prerequisite tasks as described in “Before you begin” on page 41.
2. Identify the system backplane assembly that you need to remove. For instructions, see “Identifying a failing part” on page 43.
3. Stop the system or logical partition. For instructions, see “Stopping a system or logical partition” on page 48.
4. Disconnect the power source from the system by unplugging the system.

**Note:** This system is equipped with a second power supply. Disconnect all power sources to the system before continuing with this procedure.

(L003)

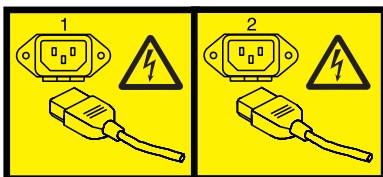

or



5. Remove the front cover. For instructions, see “Removing the front cover from the 8234-EMA, 9117-MMA, or 9406-MMA” on page 65.

**Attention:**

- Attach a wrist strap to an unpainted metal surface of your hardware to prevent electrostatic discharge (ESD) from damaging your hardware.
  - When using a wrist strap, follow all electrical safety procedures. A wrist strap is for static control. It does not increase or decrease your risk of receiving electric shock when using or working on electrical equipment.
  - If you do not have a wrist strap, just prior to removing the product from ESD packaging and installing or replacing hardware, touch an unpainted metal surface of the system for a minimum of 5 seconds.
6. Remove the SMP cable, if present, from the front of the processor. For instructions, see “Disconnecting the SMP processor cable from a system” on page 51.
  7. Remove the control panel. For instructions, see Control panel, control panel fillers, and signal cables.
  8. Remove the voltage regulator modules. Record the location of each voltage regulator module being removed. For instructions, see Voltage regulators.

---

## Removing the system backplane

You can remove the system backplane.

To remove the system backplane, complete the following steps:

1. Locate the blue handle, which is below the processor assembly.

**Attention:** The system backplane assembly is of substantial weight; do not use the blue lever to pull out the system backplane assembly. Grasp the system backplane assembly firmly with both hands when it is free of the system.

2. As shown in the following figure, pull the blue lever (**A**) to the left and out from the system to unlock the system backplane assembly, then use both hands to pull the system backplane assembly (**B**) out of the system.

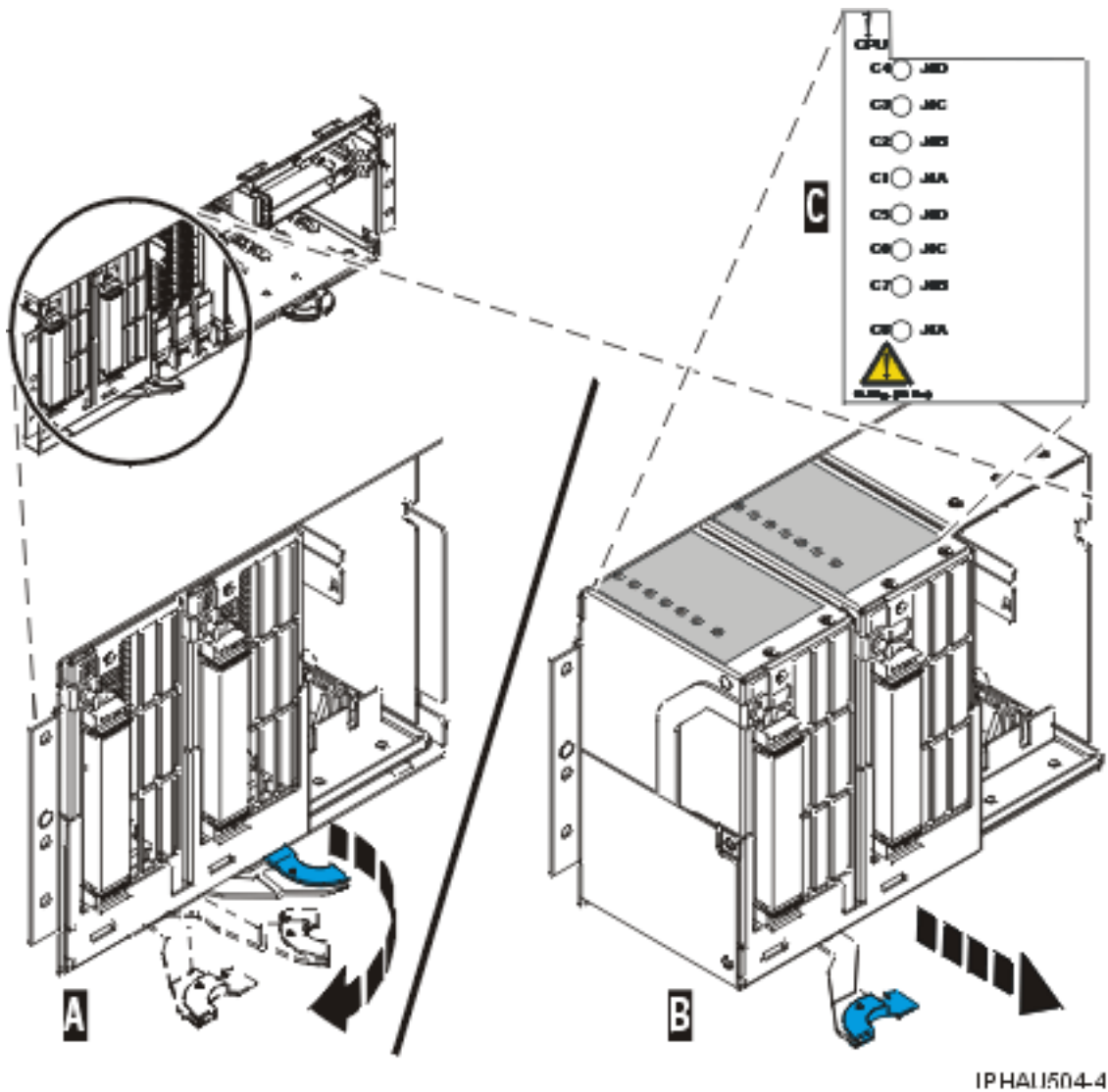

Figure 1. Sliding the 8234-EMA , 9117-MMA, or 9406-MMA system backplane assembly out of the system unit

3. If you are removing the system backplane as a part of another procedure, return to that procedure. If you are removing the system backplane because it is damaged or failing to operate correctly, continue to the next step.
4. Pull out the bracket by removing the screws at the top of the bracket, and tipping the bracket back.
5. As shown in the following figure, pull out on the locking knobs (A) until you feel them unlock. Push the locking arms (B) down and out to unlock the processor assembly, and then lift it out of the system backplane assembly (C). Remove all processor assemblies (or fillers) from the system backplane assembly.

**Tip:** Record the location of each processor assembly being removed for use during reinstallation.

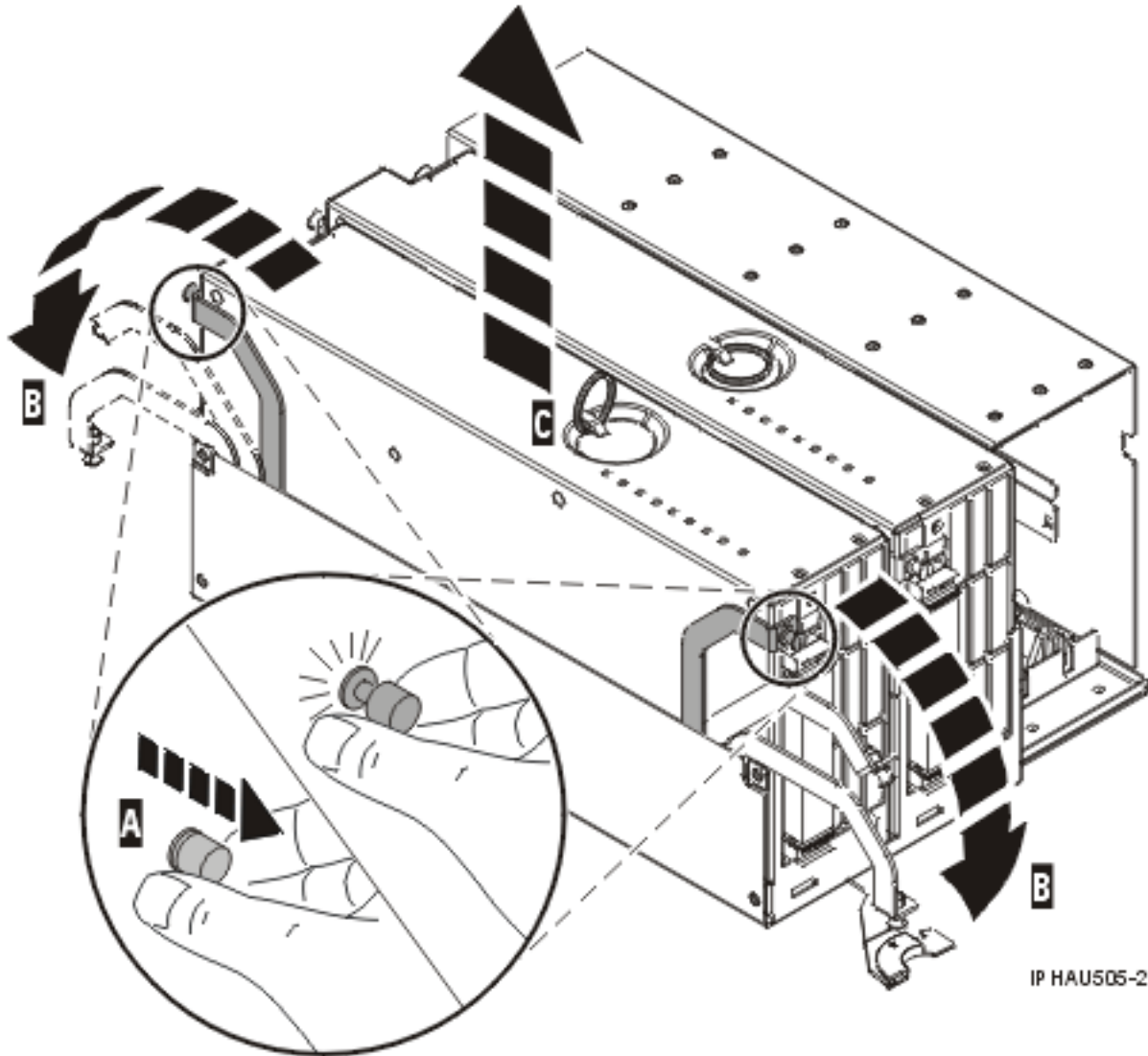

Figure 2. Removing the processor assembly from the 8234-EMA, 9117-MMA, or 9406-MMA backplane assembly

6. Place the processor assembly on a surface that is safe from electrostatic discharge.
7. Replace the system backplane. For instructions, see Chapter 2, "Replacing the 8234-EMA, 9117-MMA, or 9406-MMA system backplane," on page 7.

---

## Chapter 2. Replacing the 8234-EMA, 9117-MMA, or 9406-MMA system backplane

Learn about replacing the system backplane in the server.

To complete this procedure, you must have already completed the removal procedure. See Chapter 1, "Removing the 8234-EMA, 9117-MMA, or 9406-MMA system backplane," on page 3.

### Related information



Voltage regulators



Control panel, control panel fillers, and signal cables

---

## Replacing the system backplane

Learn about replacing the system backplane in the server.

To replace the system backplane, perform the following steps:

1. As shown in Figure 3 on page 8, place the system processor assembly into the system backplane assembly **(A)**, using the location information that you recorded during the removal procedure.
2. Lock the system processor assembly into place with the locking arms **(B)**. Press in on the locking knobs **(C)** until you feel them lock into place.
3. Replace all processor assemblies that were removed earlier.

### Attention:

- Attach a wrist strap to an unpainted metal surface of your hardware to prevent electrostatic discharge (ESD) from damaging your hardware.
- When using a wrist strap, follow all electrical safety procedures. A wrist strap is for static control. It does not increase or decrease your risk of receiving electric shock when using or working on electrical equipment.
- If you do not have a wrist strap, just prior to removing the product from ESD packaging and installing or replacing hardware, touch an unpainted metal surface of the system for a minimum of 5 seconds.

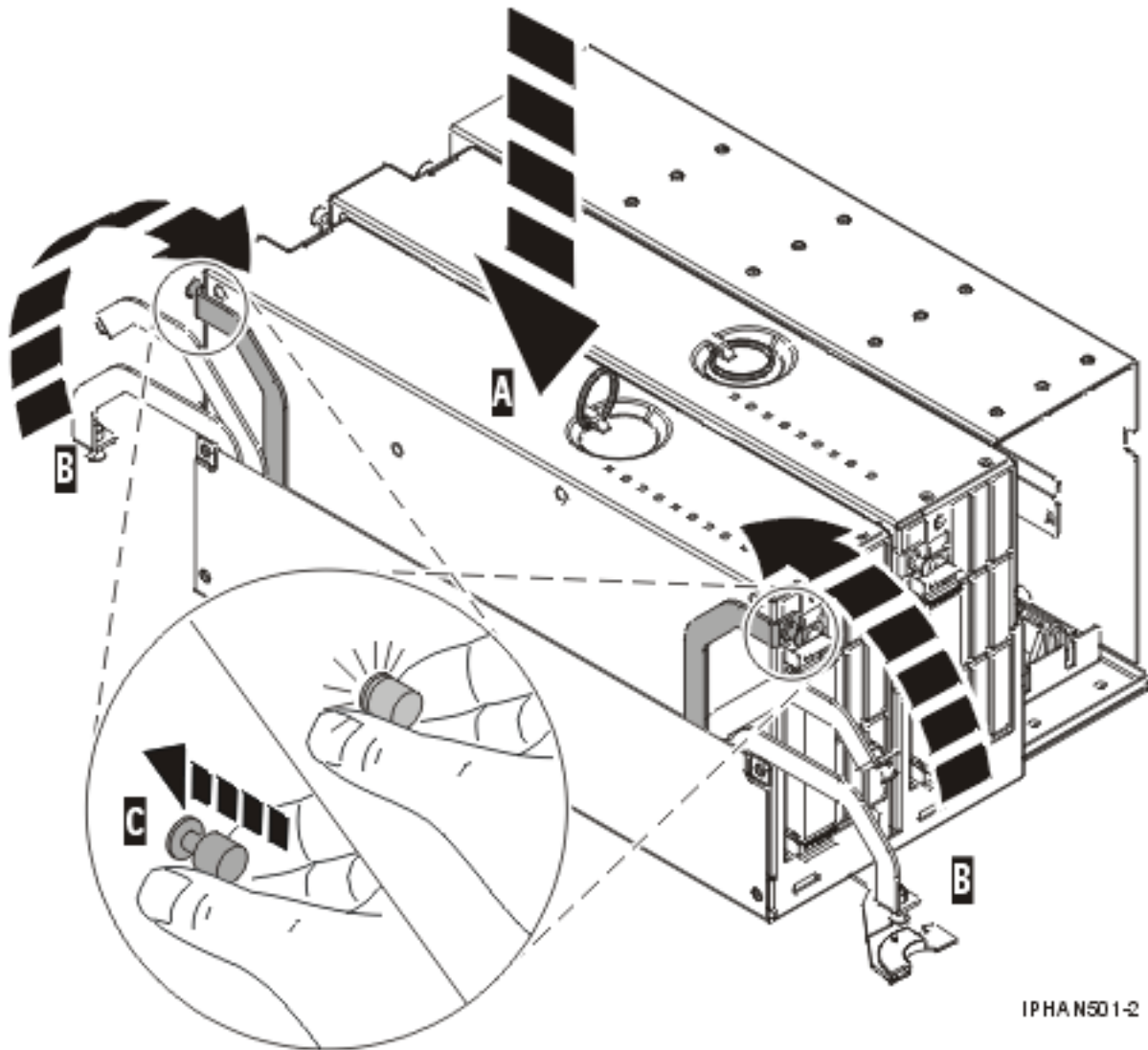

IPHAN501-2

Figure 3. Replacing the 8234-EMA, 9117-MMA, or 9406-MMA backplane assembly

4. Align the system backplane assembly with the slot in the system.
5. Slide the system backplane assembly into the system (A), as shown in Figure 4 on page 9.
6. Push the blue lever (B) to the right and in toward the system to lock the system backplane assembly.

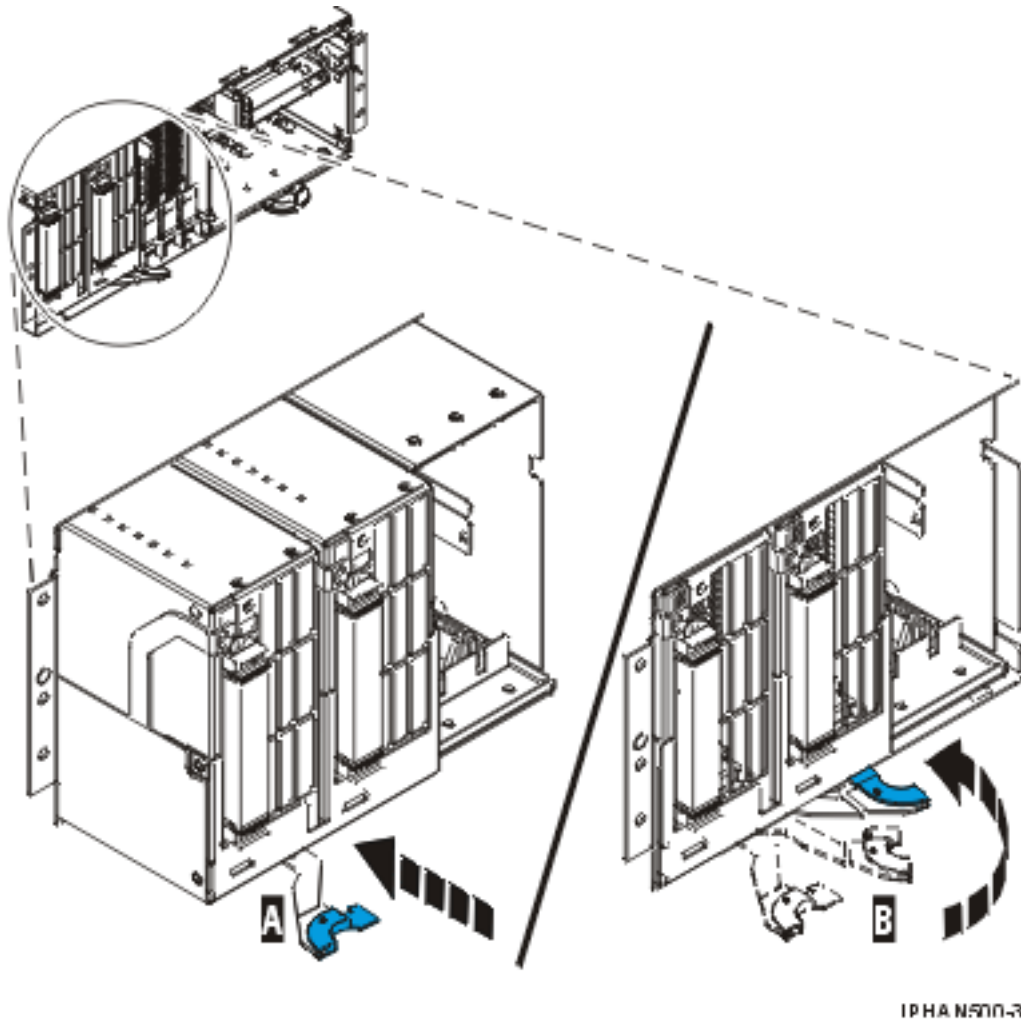

Figure 4. Sliding the 8234-EMA, 9117-MMA, or 9406-MMA system backplane assembly into the system unit

## Completing the procedure

If you removed the voltage regulator, control panel or SMP cable to replace the backplane in the system, you might need to replace those parts again. Use the procedure in this section to perform these tasks.

To replace the voltage regulator modules, control panel, or SMP cable, complete the following steps:

1. Replace the voltage regulator modules. For instructions, see Voltage regulators.
2. Replace the control panel. For instructions, see Control panel, control panel fillers, and signal cables.
3. Replace the SMP cable, if it was removed. For instructions, see “Reconnecting the SMP processor cable to a system” on page 54.

Use the SMP cable tool shown in the following figure, where available, to ensure full connector seating with the cable-end.

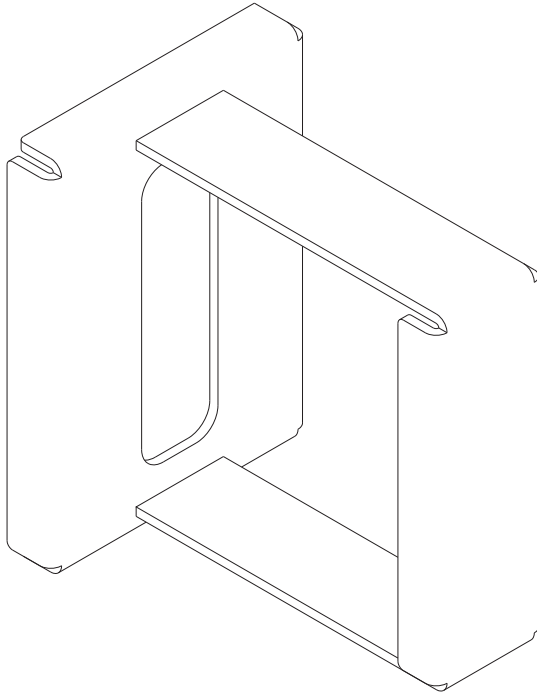

IPHBU501-0

Figure 5. SMP cable tool

Push the connector into place with firm, even pressure on both the top and the bottom of each cable end. Use the SMP tool to seat the cable, as shown in the following figure.

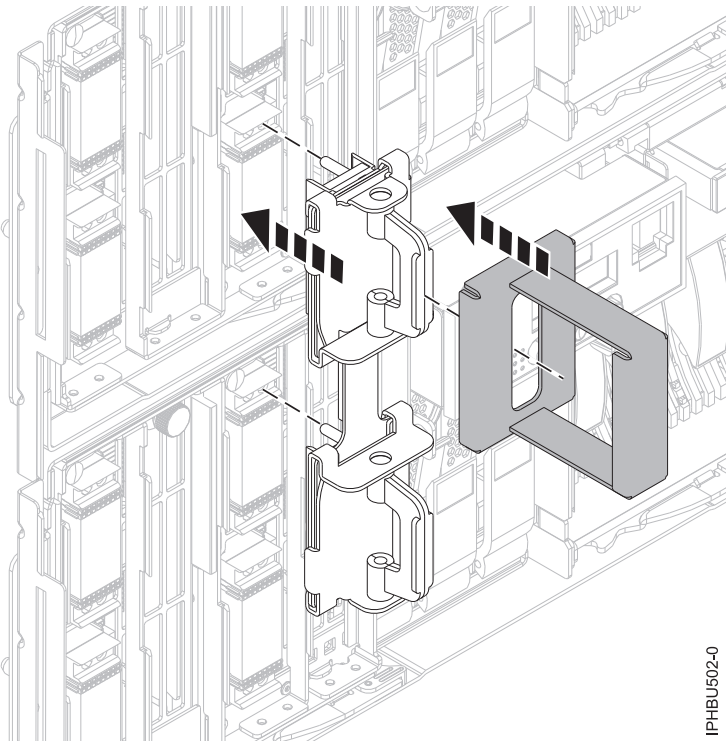

IPHBU502-0

Figure 6. Seating the cable with the SMP cable tool

4. Replace the front cover. For instructions, see “Installing the front cover on the 8234-EMA, 9117-MMA, or 9406-MMA” on page 66.
5. Start the system or logical partition. For instructions, see “Starting the system or logical partition” on page 46.
6. Do one of the following steps:
  - a. If you replaced the system backplane as part of another procedure, return to that procedure now.
  - b. If you replaced the system backplane because it was not operational, verify that the new resource is operational. For instructions, see “Hardware service manager Verify option” on page 77.



---

## Chapter 3. Removing and replacing the 8203-E4A, 8204-E8A, 8261-E4S, 9407-M15, 9408-M25, or 9409-M50 disk drive backplane

You can remove, replace, or install the disk drive backplane in the server.

You might have one of two different disk drive backplanes, the 2.5 inch small-form disk drive backplane or the 3.5 inch disk drive backplane. For steps in the removal or replacement procedures that only show a picture of one of the backplanes, the step is the same for both the 2.5 inch small-form disk drive backplane or the 3.5 inch disk drive backplane. Figure 7 shows a picture of the 2.5 inch small-form disk drive backplane, and Figure 8 shows a picture of the 3.5 inch disk drive backplane.

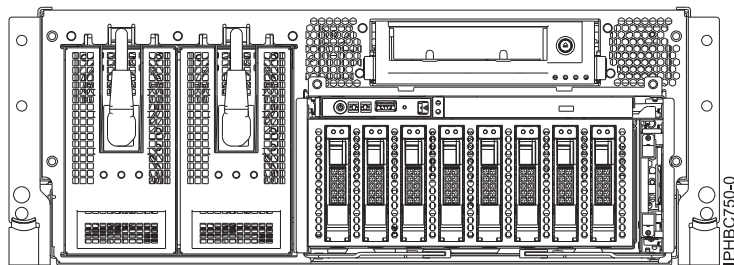

Figure 7. 2.5 inch small-form disk drive backplane

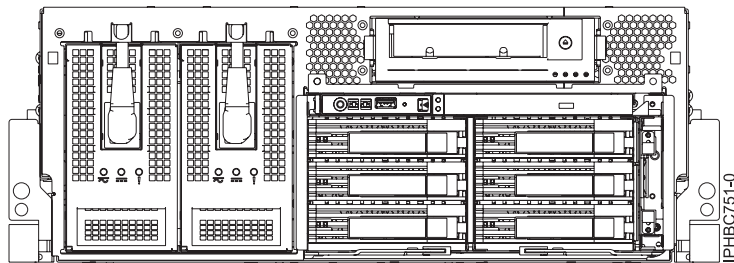

Figure 8. 3.5 inch disk drive backplane

---

### Removing the 8203-E4A, 8204-E8A, 8261-E4S, 9407-M15, 9408-M25, or 9409-M50 disk drive backplane

Learn about removing the disk drive backplane from the server.

If your system is managed by the Hardware Management Console (HMC), use the HMC to complete the steps for removing the disk drive backplane from the server. For information about using the HMC to remove the disk drive backplane, see [Removing a part using the Hardware Management Console](#).

If you do not have an HMC, complete the following steps to remove the disk drive backplane:

1. Perform the prerequisite tasks described in “Before you begin” on page 41.
2. Do one of the following steps, as applicable:
  - a. If you are removing the disk drive backplane for a system upgrade or as part of another procedure, continue to the next step.
  - b. If you are removing the disk drive backplane because of a system failure, use the service action log to help identify the failing part. See “Identifying a failing part” on page 43.

3. Stop the system or logical partition. For instructions, see “Stopping a system or logical partition” on page 48.
4. Disconnect the power source from the system by unplugging the system.

**Note:** This system might be equipped with a second power supply. Before continuing with this procedure, ensure that the power source to the system has been completely disconnected.

(L003)

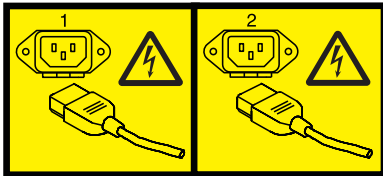

or



5. Remove the front cover. See “Removing the front cover from a rack-mounted 8203-E4A, 8204-E8A, 8261-E4S, 9407-M15, 9408-M25, or 9409-M50” on page 61 or “Removing the front cover from the stand-alone 8203-E4A, 8204-E8A, 8261-E4S, 9407-M15, 9408-M25, or 9409-M50” on page 63.

**Attention:**

- Attach a wrist strap to an unpainted metal surface of your hardware to prevent electrostatic discharge (ESD) from damaging your hardware.
  - When using a wrist strap, follow all electrical safety procedures. A wrist strap is for static control. It does not increase or decrease your risk of receiving electric shock when using or working on electrical equipment.
  - If you do not have a wrist strap, just prior to removing the product from ESD packaging and installing or replacing hardware, touch an unpainted metal surface of the system for a minimum of 5 seconds.
6. Place the system into the service position. See “Placing a rack-mounted 8203-E4A, 8204-E8A, 8261-E4S, 9407-M15, 9408-M25, or 9409-M50 in the service position” on page 72.
  7. Remove the service access cover. See “Removing the service access cover from a rack-mounted 8203-E4A, 8204-E8A, 8261-E4S, 9407-M15, 9408-M25, or 9409-M50” on page 57 or “Removing the service access cover from a stand-alone 8203-E4A, 8204-E8A, 8261-E4S, 9407-M15, 9408-M25, or 9409-M50” on page 59
  8. Remove the fans and either the airflow cover or the fan cage, depending on your system:

- a. For the 8204-E8A or 9409-M50, perform the following steps:
- 1) To remove the fans, squeeze the tab (A) and lift the fan out of the fan cage as shown in Figure 9.

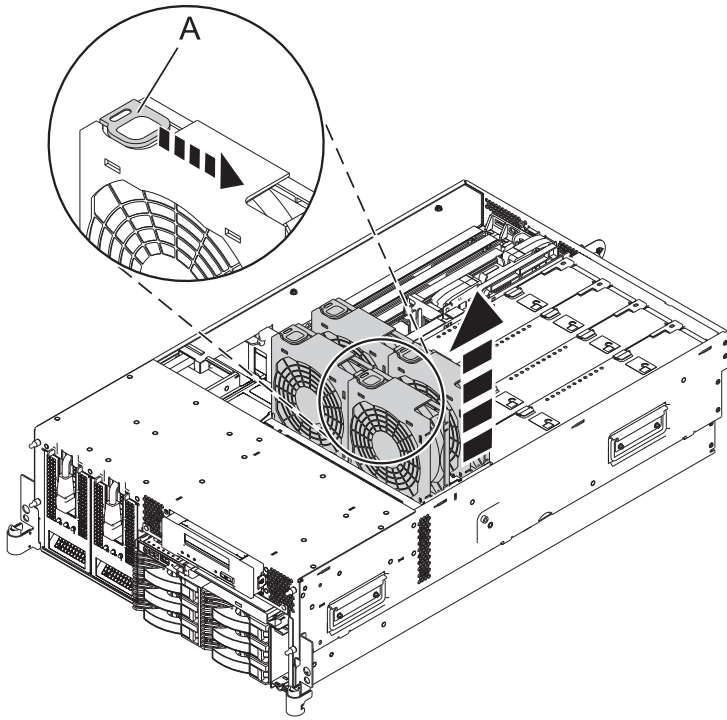

Figure 9. Removing the fan from the 8204-E8A or 9409-M50 fan cage

- 2) To remove the air baffles, grasp and pull the air baffle out of the fan cage, as shown in Figure 10 on page 16.

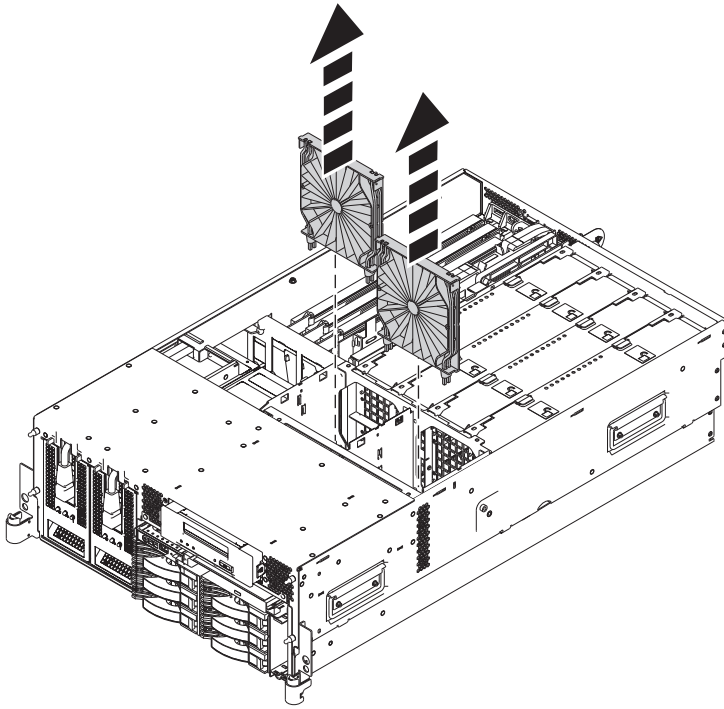

Figure 10. Removing the air baffles from the 8204-E8A or 9409-M50 fan cage

- 3) To remove the fan cage, loosen the two thumbscrews (A) and lift the fan cage (B) out of the system as shown in Figure 11.

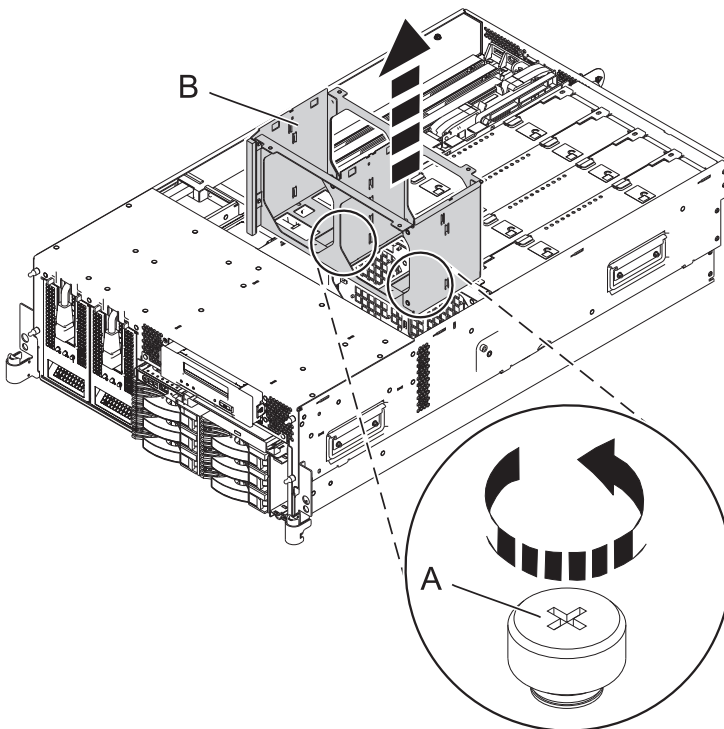

Figure 11. Removing the fan cage from the 8204-E8A or 9409-M50 system

b. For the 8203-E4A, 8261-E4S, 9407-M15, or 9408-M25, perform the following steps:

- 1) To remove the fans, lift the latch (A) upward and pull each fan (B) out of the airflow cover as shown in Figure 12.

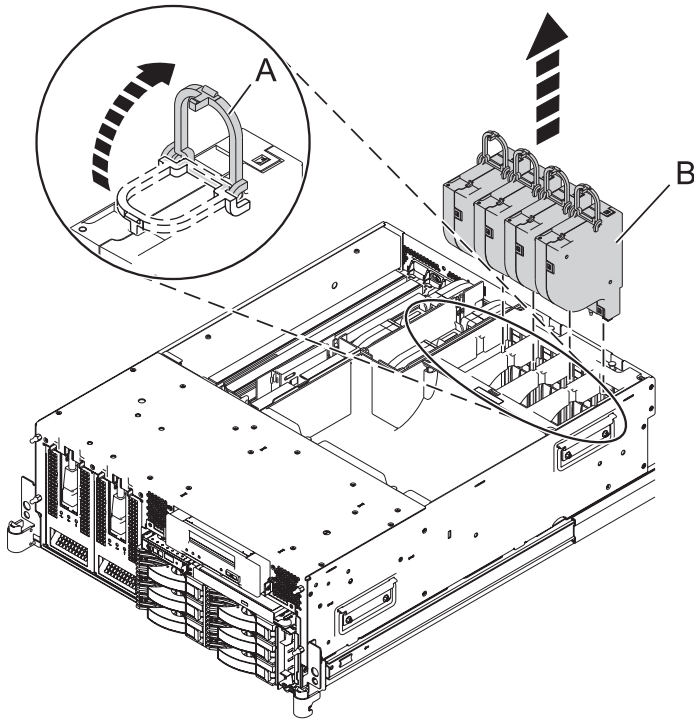

Figure 12. Removing the fans from the 8203-E4A, 8261-E4S, 9407-M15, or 9408-M25 airflow cover

- 2) To remove the airflow cover (B), lift each of the four tabs (A) to release the cover, and lift the cover off of the system, as shown in Figure 13 on page 18.

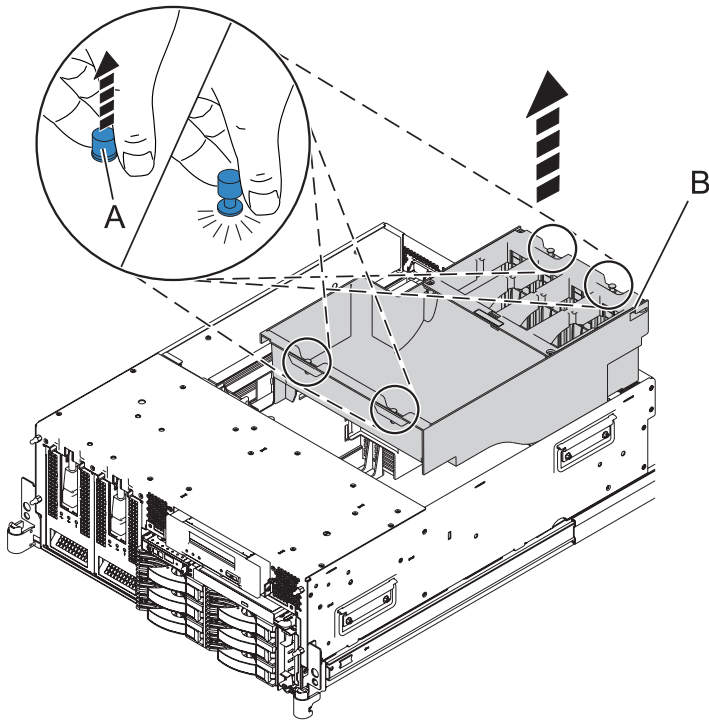

Figure 13. Removing the airflow cover from the 8203-E4A, 8261-E4S, 9407-M15, or 9408-M25 system

9. Disconnect the cables from the back of the disk drive backplane, as shown in one of the following figures.

**Note:** Ensure that you have disconnected all cables from the backplane. Some of the cables might not be shown in the following figures.

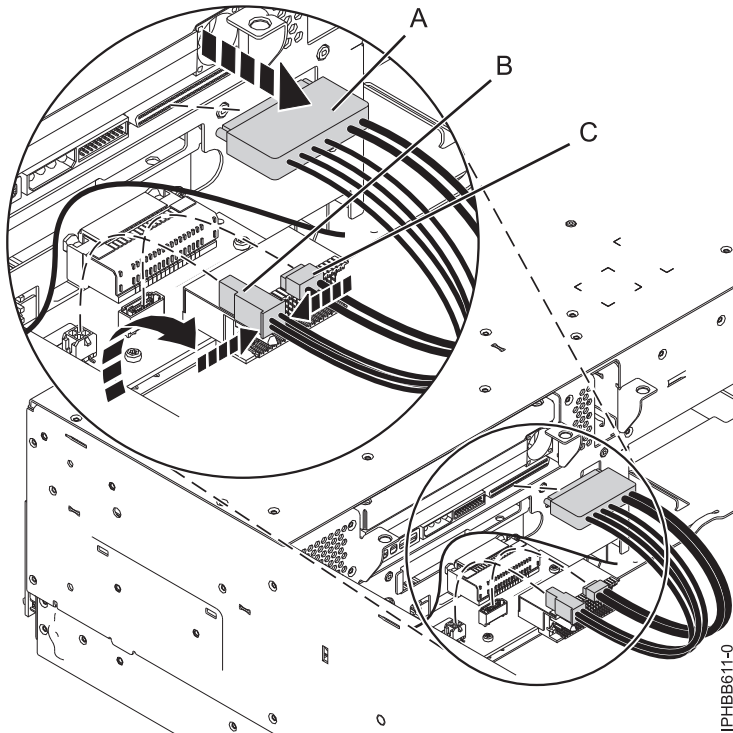

Figure 14. Disconnecting the media device cables from the 2.5 inch small-form disk drive backplane

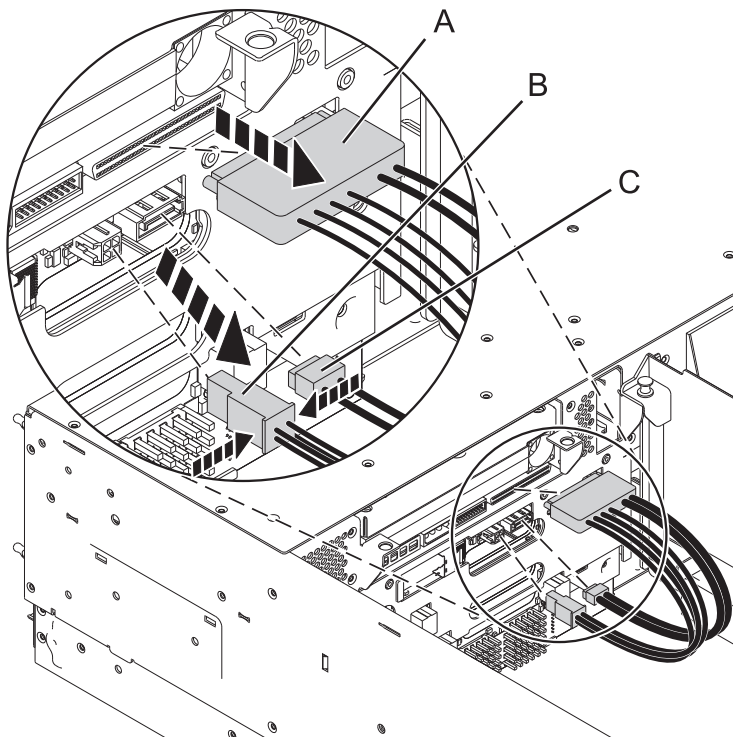

Figure 15. Disconnecting the media device cables from the 3.5 inch disk drive backplane

10. If you need to replace the backplane because of an upgrade or system failure, complete one of the following steps to remove the disk drives, depending on your backplane:

**Note:** If you remove a backplane that is populated with disk drives, the backplane will be heavy. Ensure that you can safely complete the procedure.

- a. To remove the disk drive from the 2.5 inch small-form disk drive backplane, perform the following steps. Record the location of each of the disk drives you remove. The disk drives must be reinstalled to the same location again.
  - 1) Unlock the disk drive handle (A) and pull it toward you to unseat the disk drive.
  - 2) Place one hand under the disk drive and carefully pull the drive out of the system as shown in Figure 16.

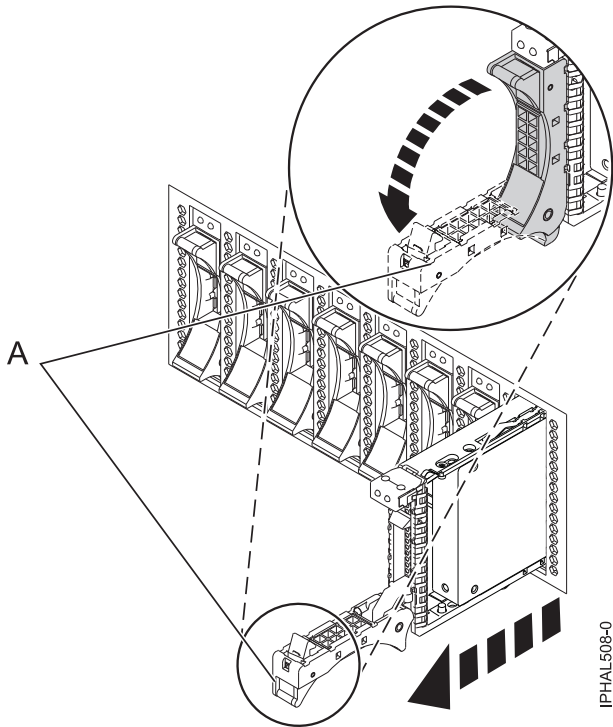

Figure 16. Removing the disk drive from the 2.5 inch small-form disk drive backplane

- b. To remove the disk drive from the 3.5 inch disk drive backplane, perform the following steps. Record the location of each of the disk drives you remove. The disk drives must be reinstalled to the same location again.
  - 1) Gently lift and move the disk drive handle (A) away from the system to unseat the disk drive.
  - 2) Place one hand under the disk drive and carefully pull the drive out of the system as shown in Figure 17 on page 21.

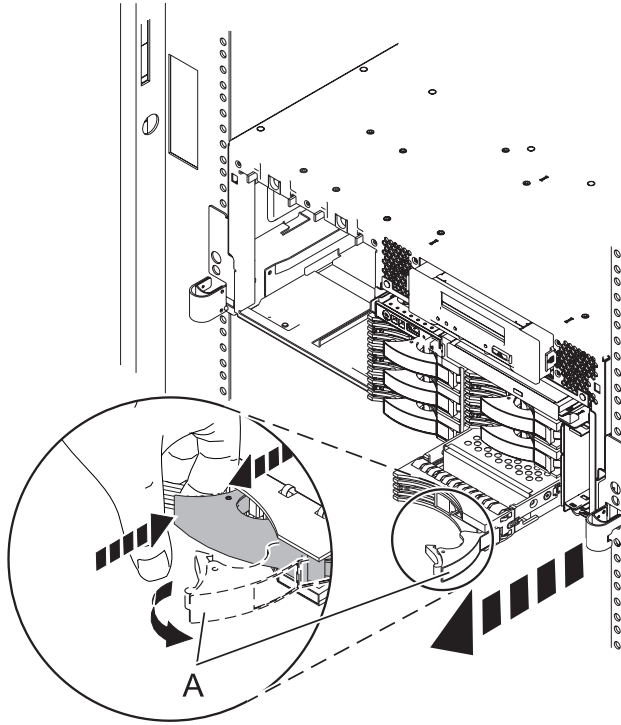

Figure 17. Removing the disk drive from the 3.5 inch disk drive backplane

11. Remove the media device by pressing in on the latch (A) and sliding the media device out of the system, as shown in Figure 18.

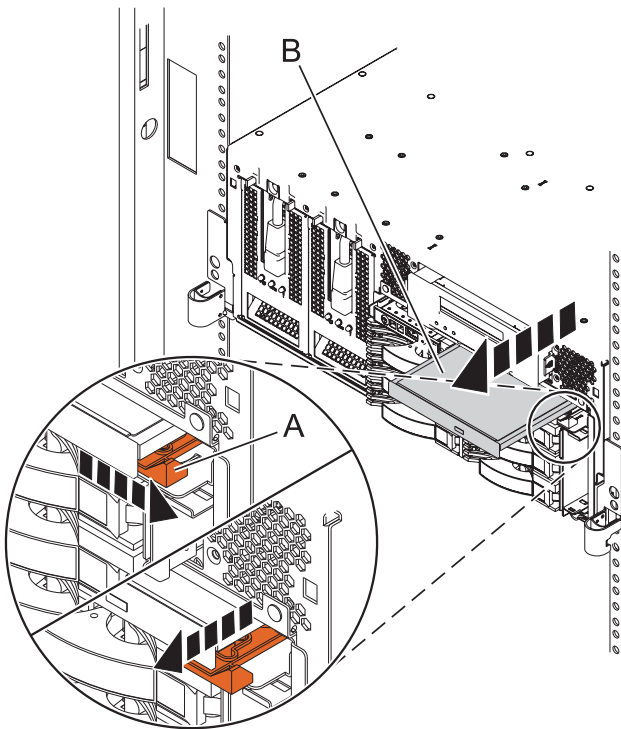

Figure 18. Removing the media device from the disk drive backplane

12. Unlock the disk drive backplane by pulling the handles open from the center of the backplane.
13. Pull the backplane out of the server as shown in Figure 19, Figure 20, or Figure 21 on page 23.

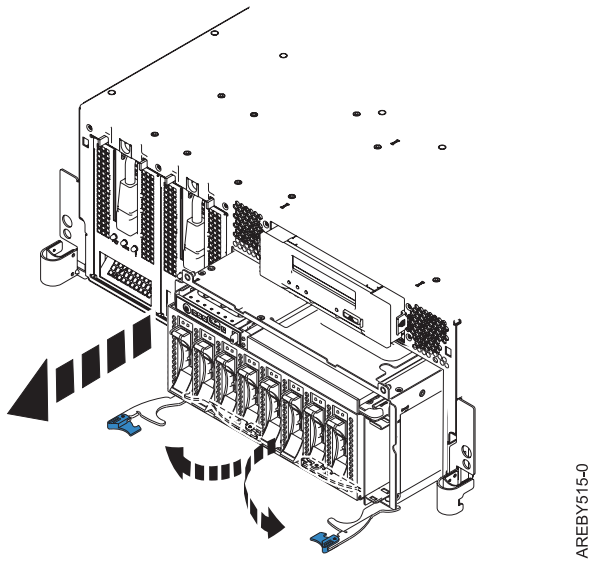

Figure 19. Removing the populated 2.5 inch small-form disk drive backplane

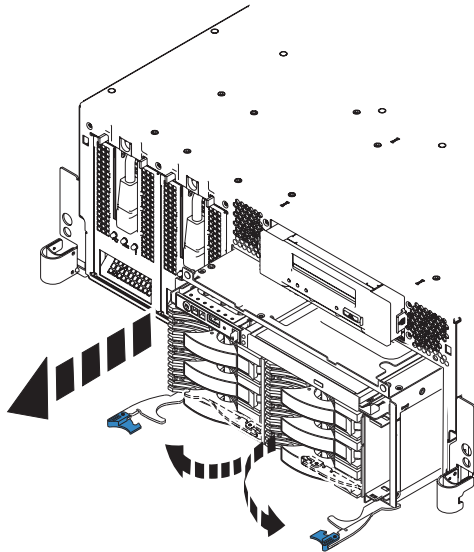

Figure 20. Removing the populated 3.5 inch disk drive backplane

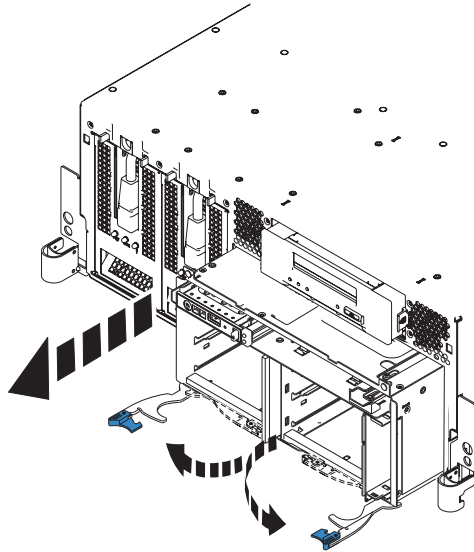

Figure 21. Removing the unpopulated disk drive backplane

14. Remove the control panel, signal cable, and USB cable from the backplane to use in the replacement backplane. For instructions, see Control panel, control panel fillers, and signal cables.
15. If you removed the backplane as a part of another procedure, continue with that procedure. To replace the backplane or to install a new backplane, see “Replacing the 8203-E4A, 8204-E8A, 8261-E4S, 9407-M15, 9408-M25, or 9409-M50 disk drive backplane.”

---

## Replacing the 8203-E4A, 8204-E8A, 8261-E4S, 9407-M15, 9408-M25, or 9409-M50 disk drive backplane

If you removed the disk drive backplane as a part of another procedure, you might need to use the procedure in this section to replace the disk drive backplane.

If your system is managed by the Hardware Management Console (HMC), use the HMC to complete the steps for replacing the disk drive backplane in the server. For instructions, see Exchanging a part using the Hardware Management Console.

If you do not have an HMC, complete the following steps to replace the disk drive backplane:

1. Perform the prerequisite tasks described in “Before you begin” on page 41.
2. Install the control panel, signal cable, and USB cable. For instructions, see Control panel, control panel fillers, and signal cables.
3. Check for a protective cover that might be present on the lower right connector pins. If a protective cover is present, remove the cover (A), as shown in Figure 22 on page 24.

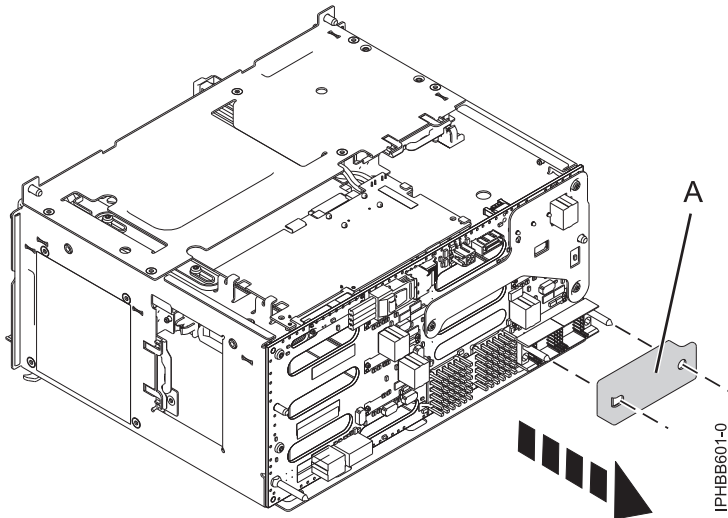

Figure 22. Picture of removing the protective cover from the connector pins

4. Carefully lift the backplane along two sides and align with the slot in the server.

**Important:** If you remove a backplane that is populated with disk drives, the backplane will be heavy. Ensure that you can safely perform this task before you begin.

5. Insert the backplane firmly into the server, as shown in the following figures.
6. Secure the backplane with the locking tabs.

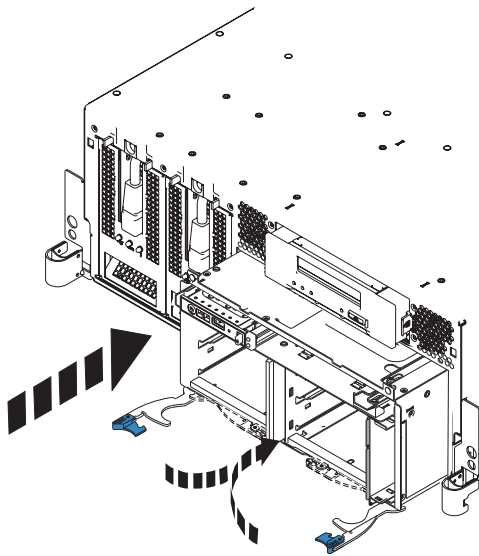

Figure 23. Installing the unpopulated disk drive backplane on a rack-mounted model

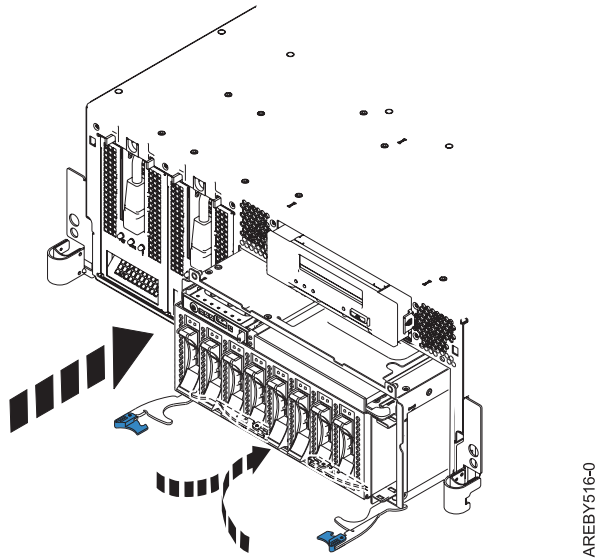

Figure 24. Installing the populated 2.5 inch small-form disk drive backplane on a rack-mounted model

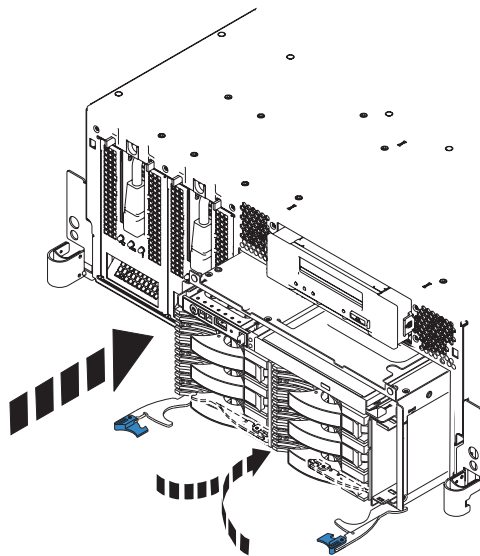

Figure 25. Installing the populated 3.5 inch disk drive backplane on a rack-mounted model

7. Connect the cables to the backplane, as shown in one of the the following figures.

**Note:** Ensure that you connect any additional cables not shown in the figure.

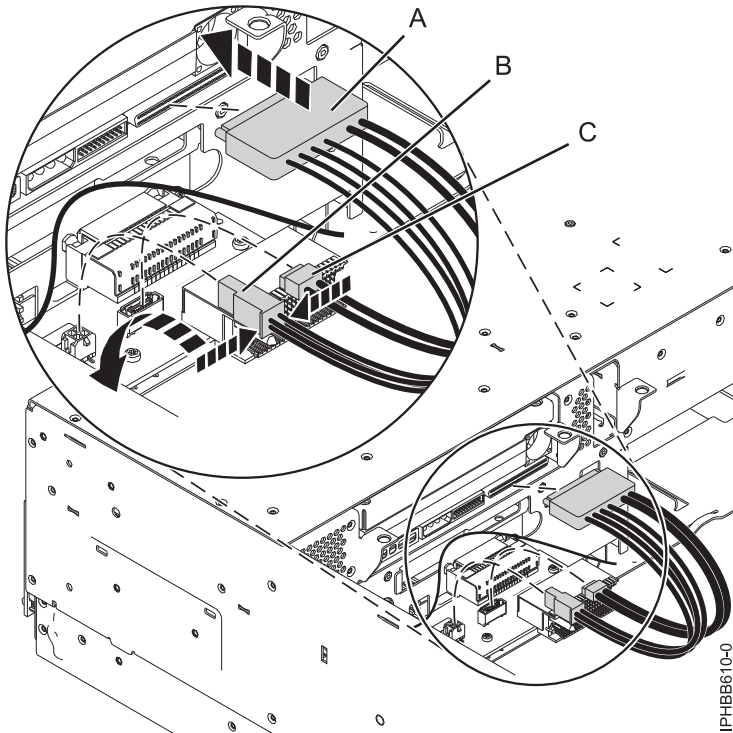

Figure 26. Connecting the cables to the 2.5 inch small-form disk drive backplane

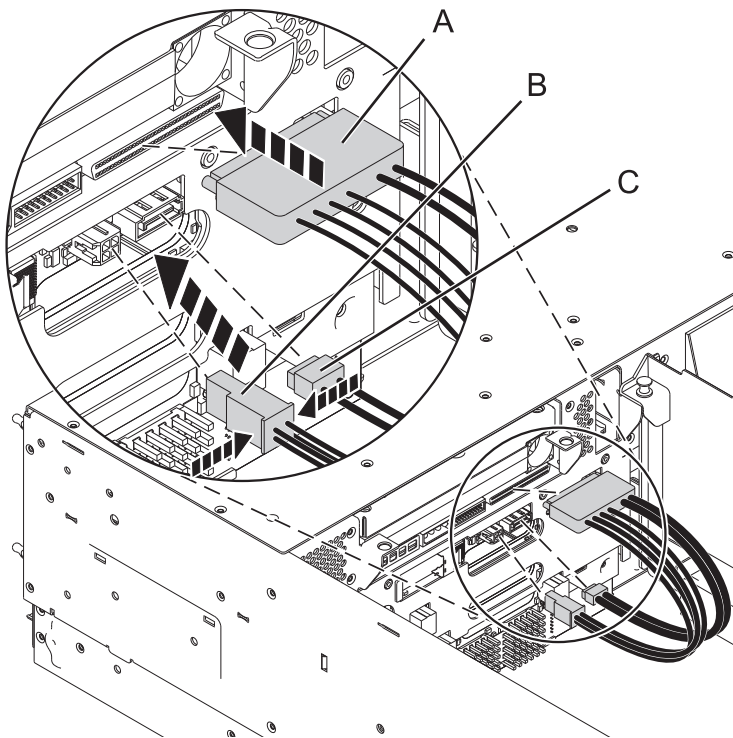

Figure 27. Connecting the cables to the 3.5 inch disk drive backplane

8. Replace the disk drives, if you removed them earlier. Use one of the following procedures, depending on your backplane:

- To replace the disk drives for the 2.5 inch small-form disk drive backplane, perform the following steps:
  - a. Support the bottom of the disk drive as you align it with the guide rails in the system or expansion unit. Do not hold the disk drive by the handle.
  - b. Slide the disk drive all the way into the system or expansion unit, and push the disk drive handle (A) in until it locks, as shown in the following figure.

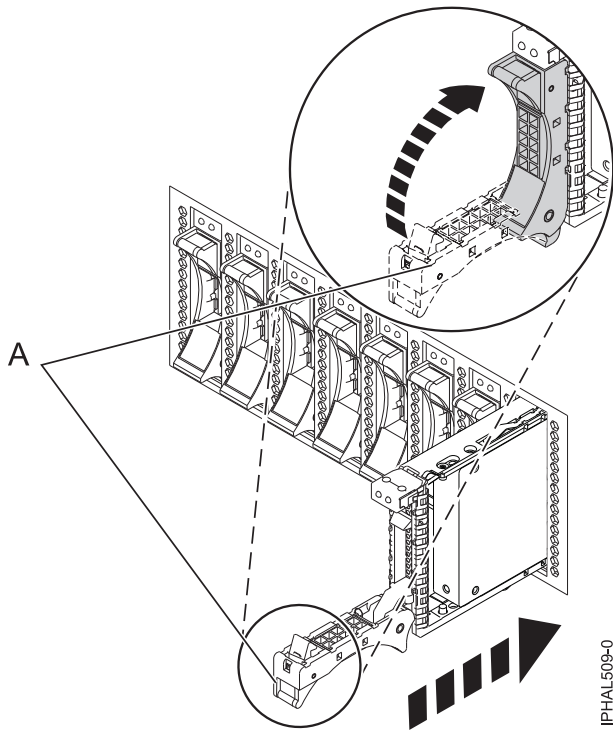

Figure 28. Installing the disk drives for the 2.5 inch small-form disk drive backplane

- To replace the disk drives for the 3.5 inch disk drive backplane, perform the following steps:
  - a. Support the bottom of the disk drive as you align it with the guide rails in the system or expansion unit. Do not hold the disk drive by the handle.
  - b. Slide the disk drive all the way into the system or expansion unit, and then lock it in place by pushing in the disk drive handle.

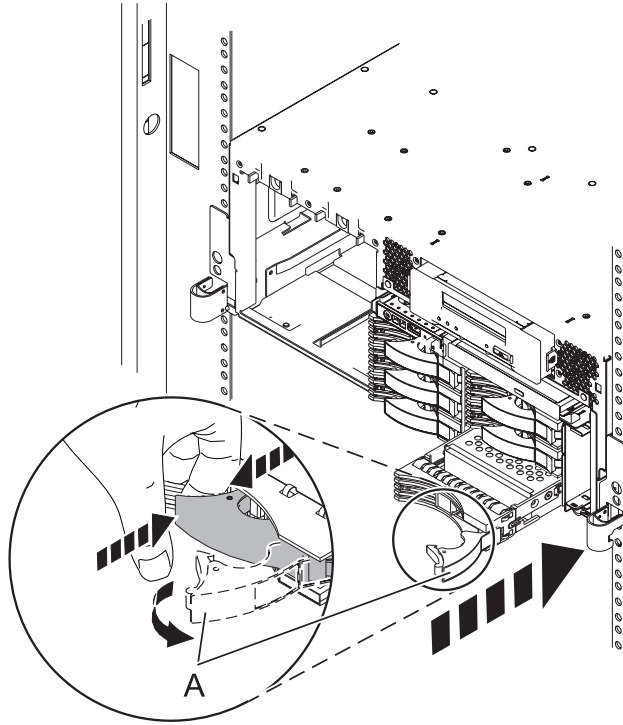
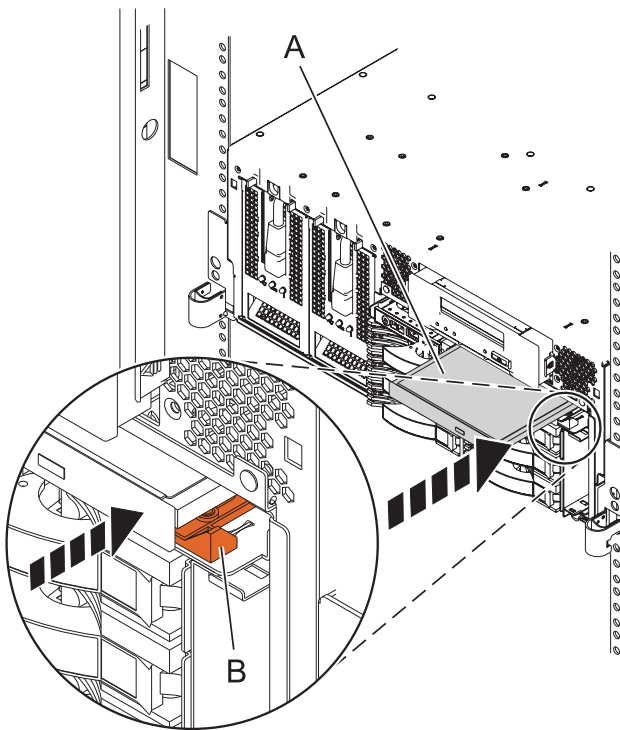

Figure 29. Installing the disk drives for the 3.5 inch disk drive backplane

9. Replace the Slimline media device by inserting it into the slot and pushing it in until the lever (B) locks into place, as shown in the following figure.



10. Replace the fans and either the airflow cover or the fan cage, depending on your system:
  - a. For the 8204-E8A or 9409-M50, perform the following steps:

- 1) To Install the fan cage (A) into the system, align the locator pins (A) through the holes, and tighten the two thumbscrews (B), as shown in Figure 30.

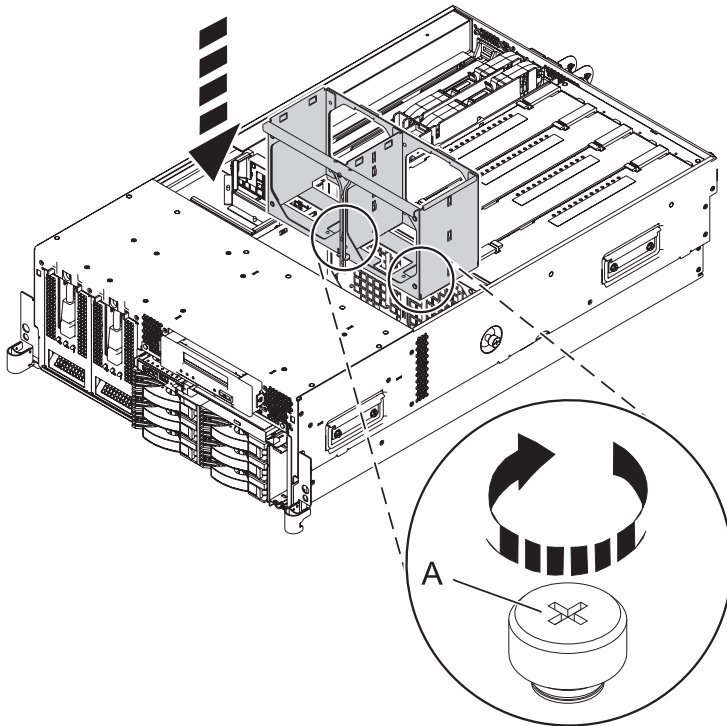

Figure 30. Installing the fan cage in the 8204-E8A or 9409-M50 system

- 2) To install the air baffles, insert the air baffles into their location in the fan cage, and push down until they lock into place, as shown in Figure 31 on page 30.

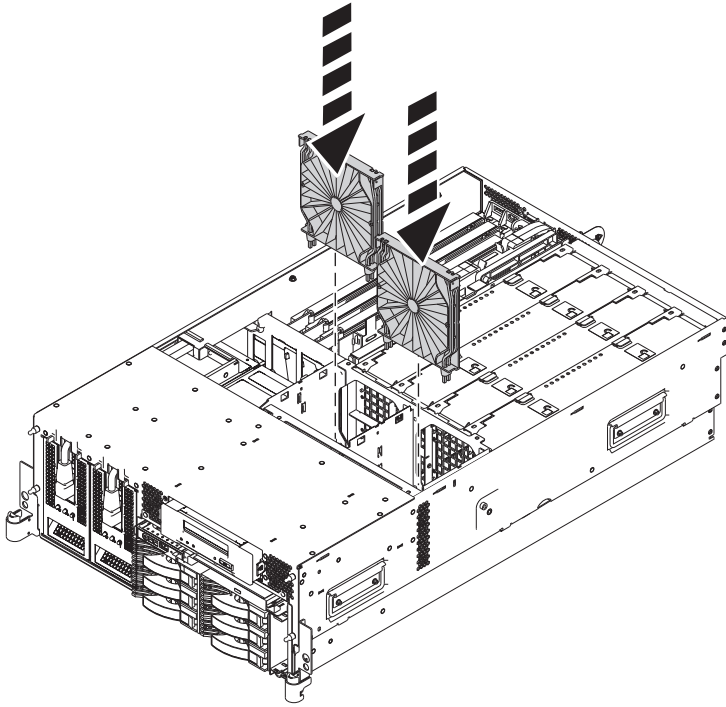

Figure 31. Installing the air baffles in the 8204-E8A or 9409-M50 fan cage

- 3) To install the fans, insert the fans into their location in the fan cage, and push down on the fan until it locks into place, as shown in Figure 32.

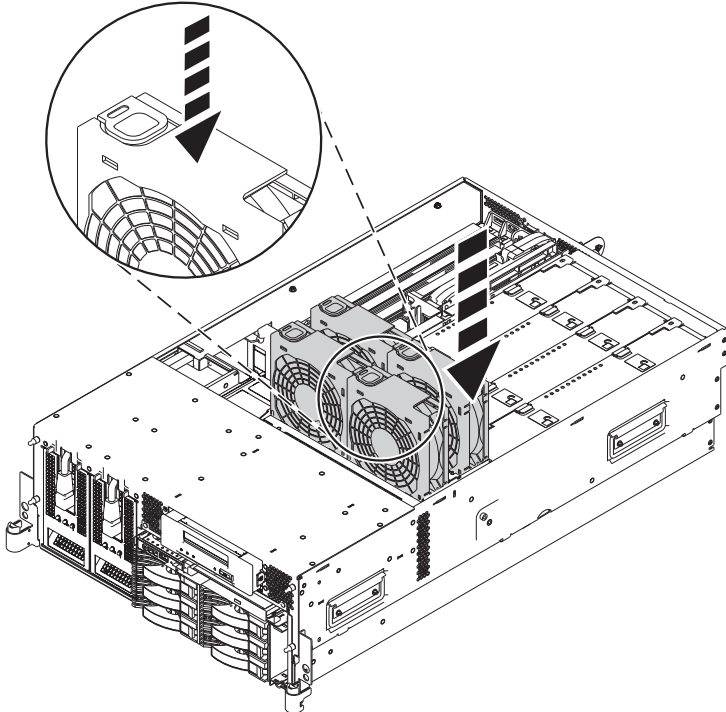

Figure 32. Installing the fans in the 8204-E8A or 9409-M50 fan cage

b. For the 8203-E4A, 8261-E4S, 9407-M15, or 9408-M25, perform the following steps:

- 1) To install the airflow cover, check that the four retaining tabs (**A**) are in open position, place the airflow cover (**A**) into its location, aligning the blue tabs with the holes. Push firmly on the cover to position it, and push the four locking tabs down to secure the cover, as shown in Figure 33.

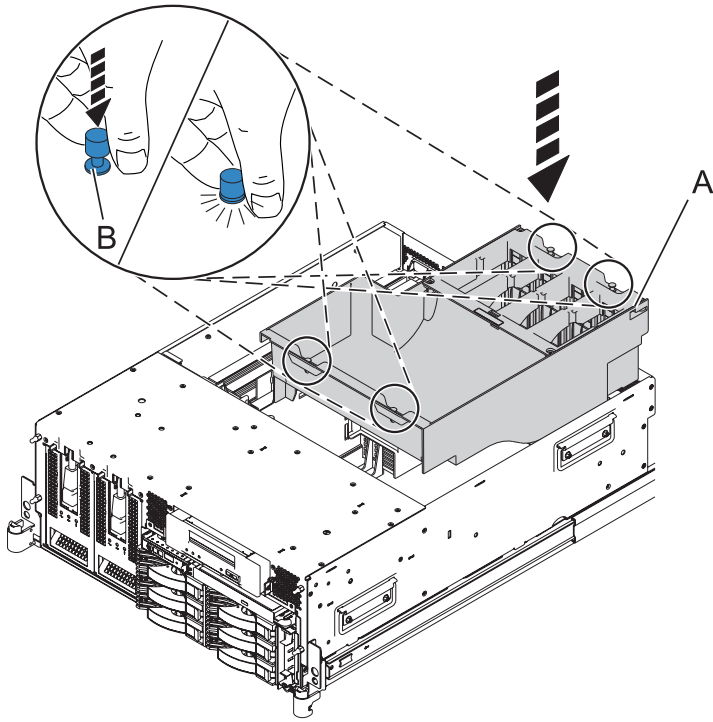

Figure 33. Installing the airflow cover in the 8203-E4A, 8261-E4S, 9407-M15, or 9408-M25 system

- 2) To install the fans, insert each fan (**A**) into its location in the airflow cover, push down on the fan until it locks into place, and close the latch (**B**), as shown in Figure 34 on page 32.

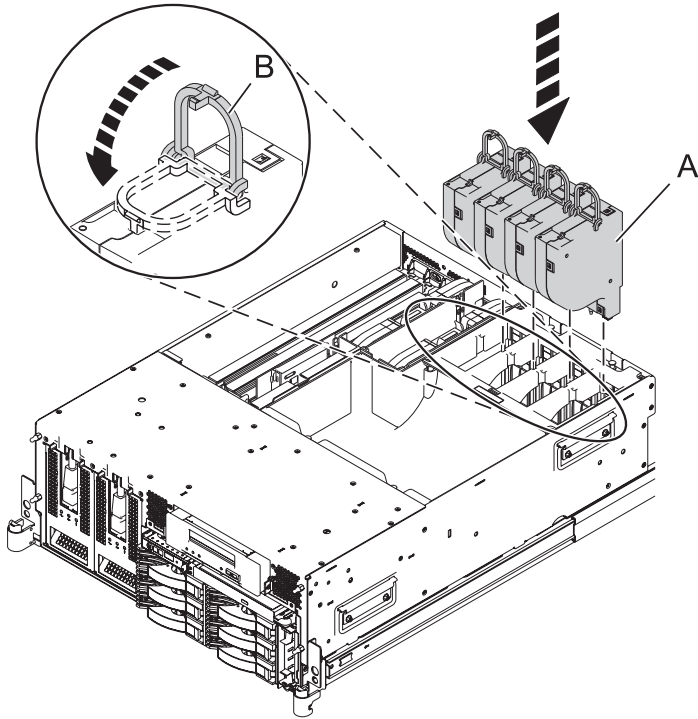

Figure 34. Installing the fans in the 8203-E4A, 8261-E4S, 9407-M15, or 9408-M25 airflow cover

11. Replace the service access cover. See “Installing the service access cover on a rack-mounted 8203-E4A, 8204-E8A, 8261-E4S, 9407-M15, 9408-M25, or 9409-M50” on page 58.
12. Replace the front cover. For instructions, see “Installing the front cover on a rack-mounted 8203-E4A, 8204-E8A, 8261-E4S, 9407-M15, 9408-M25, or 9409-M50” on page 62 or see “Installing the service access cover on a rack-mounted 8203-E4A, 8204-E8A, 8261-E4S, 9407-M15, 9408-M25, or 9409-M50” on page 58.
13. Place the system in the operating position. For rack mounted models, see “Placing the rack-mounted 8203-E4A, 8204-E8A, 8261-E4S, 9407-M15, 9408-M25, or 9409-M50 in the operating position” on page 75.
14. Start the system or logical partition. See “Starting the system or logical partition” on page 46.
15. Verify the installed part. For instructions, see “Hardware service manager Verify option” on page 77.

---

## Chapter 4. Removing and replacing the disk drive backplane in the 5802 or 5877 expansion unit

Learn about removing and replacing the disk drive backplane in the 5802 or 5877 expansion unit.

---

### Removing the disk drive backplane from the 5802 or 5877 expansion unit

You can remove the disk drive backplane from the 5802 expansion unit or backplane filler from the 5877 expansion unit.

If your system is managed by the Hardware Management Console (HMC), use the HMC to complete the steps for removing the disk drive backplane from the server. For information about using the HMC to remove the disk drive backplane, see *Removing a part using the Hardware Management Console*.

If you do not have an HMC, complete the following steps to remove the disk drive backplane:

1. Perform the prerequisite tasks as described in “Before you begin” on page 41.
2. Do one of the following steps, as applicable:
  - a. If you are removing the disk drive backplane for a system upgrade or as part of another procedure, continue to step 3.
  - b. If you are removing the disk drive backplane because of a system failure, use the service action log to help identify the failing part. See “Identifying a failing part” on page 43.
3. Stop the system or logical partition. For instructions, see “Stopping a system or logical partition” on page 48.
4. Disconnect power from the 5802 expansion unit by unplugging the system.

**Note:** This system might be equipped with a second power supply. Before continuing with this procedure, ensure that the power source to the system has been completely disconnected.

(L003)

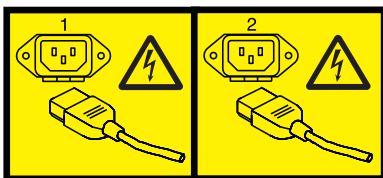

or



5. Open the front rack door.
6. Remove the disk drives and fillers from the backplane in the 5802 expansion unit as shown in Figure 35. Record the location of each of the disk drives you remove. The disk drives must be reinstalled to the same location again.
  - a. Squeeze the latch of the disk drive and pull the handle (A) toward you to release the drives.
  - b. Supporting the bottom of the disk drive with your hand, slide it out of the backplane.

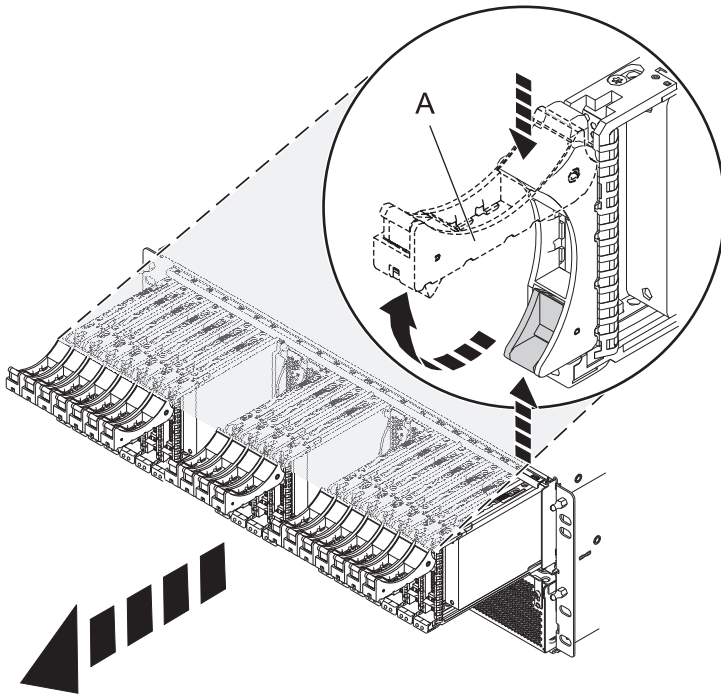

Figure 35. Removing the disk drives from the backplane

7. Remove the port cards and fillers from the backplane in the 5802 expansion unit as shown in Figure 36 on page 35.

- a. Grasp the end of the latching handle (A) and pull it upward to unlock the port card.
- b. Using your hand to support the bottom of the port card, slide it out of the backplane.
- c. Place the port card on an electrostatic discharge (ESD) surface.

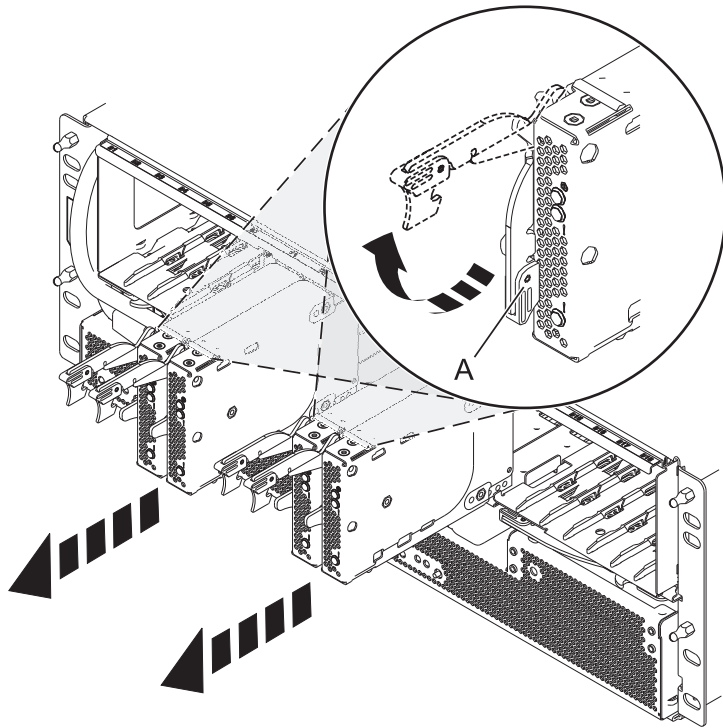

Figure 36. Removing the port card from the backplane

8. Remove the backplane from the 5802 expansion unit as shown in Figure 37 on page 36 or the backplane filler from the 5877 expansion unit as shown in Figure 38 on page 36.

**CAUTION:**

The backplane in the 5802 expansion unit might be heavy. Ensure that you can safely complete the procedure.

- a. Squeeze the blue latches (A) to unlock the handles.
- b. Pull the handles (B) outward in the direction shown to release the backplane.
- c. Slide the backplane out of the enclosure, using your hand to support the bottom of the backplane.

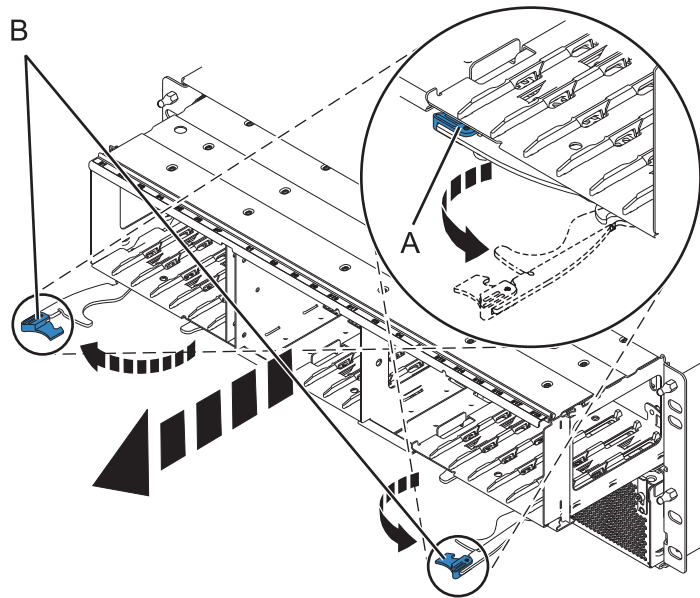

Figure 37. Removing the backplane from the enclosure

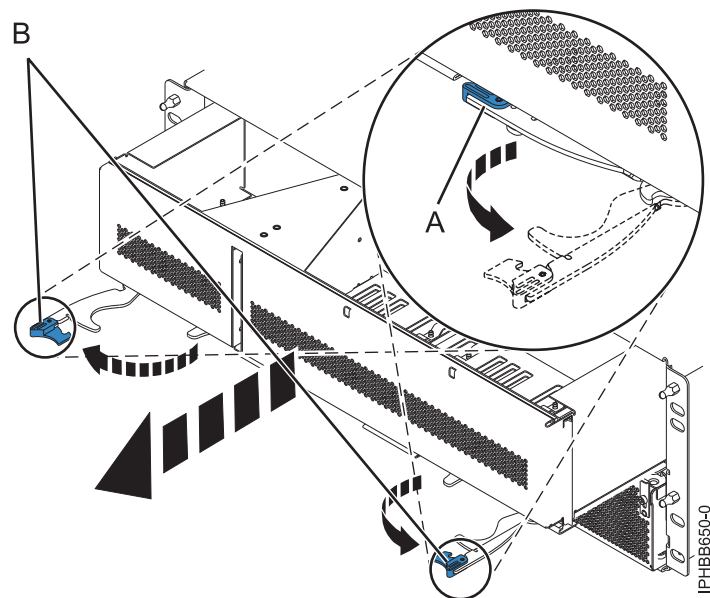

Figure 38. Removing the backplane filler from the enclosure

## Replacing the disk drive backplane in the 5802 or 5877 expansion unit

Learn about replacing the disk drive backplane or the backplane filler.

If your system is managed by the Hardware Management Console (HMC), use the HMC to complete the steps for replacing the disk drive backplane in the server. For instructions, see *Exchanging a part using the Hardware Management Console*.

If you do not have an HMC, complete the following steps to replace the disk drive backplane:

1. Perform the prerequisite tasks as described in “Before you begin” on page 41.
2. To replace the disk drive backplane or backplane filler, lift the backplane along the two sides and align it with the guide rails in the expansion unit.

**CAUTION:**

**The backplane for the 5802 expansion unit might be heavy. Ensure that you can safely perform this task before you begin.**

3. Using your hand to support the bottom of the backplane or backplane filler, slide it into the expansion unit as shown in Figure 39 or Figure 40 on page 38.
4. Secure the backplane in place by moving the locking tabs from the open position (**B**) to the locked position (**A**).

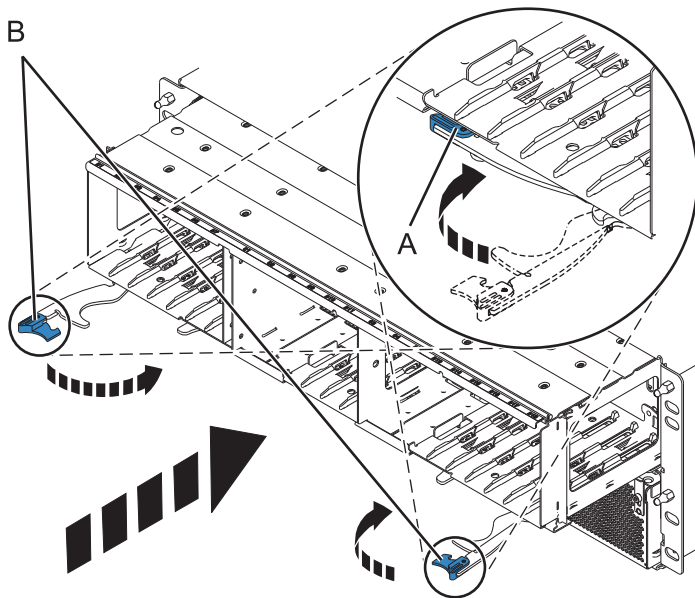

Figure 39. Installing the backplane on a rack-mounted model

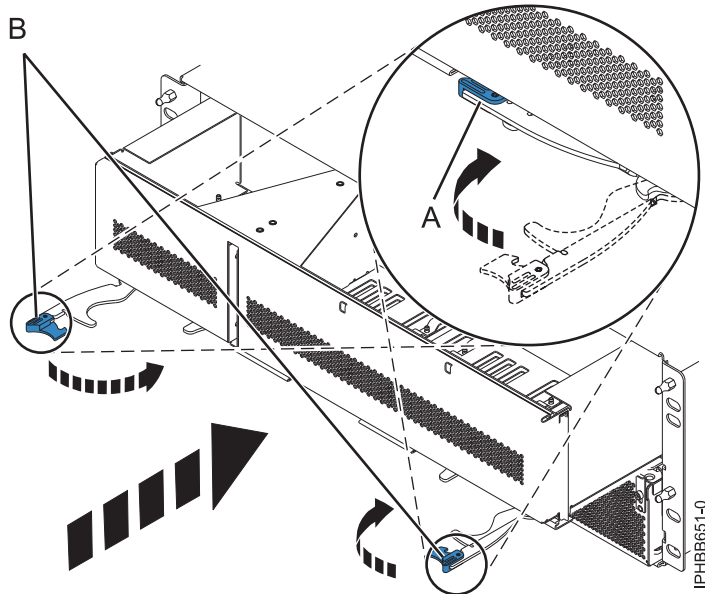
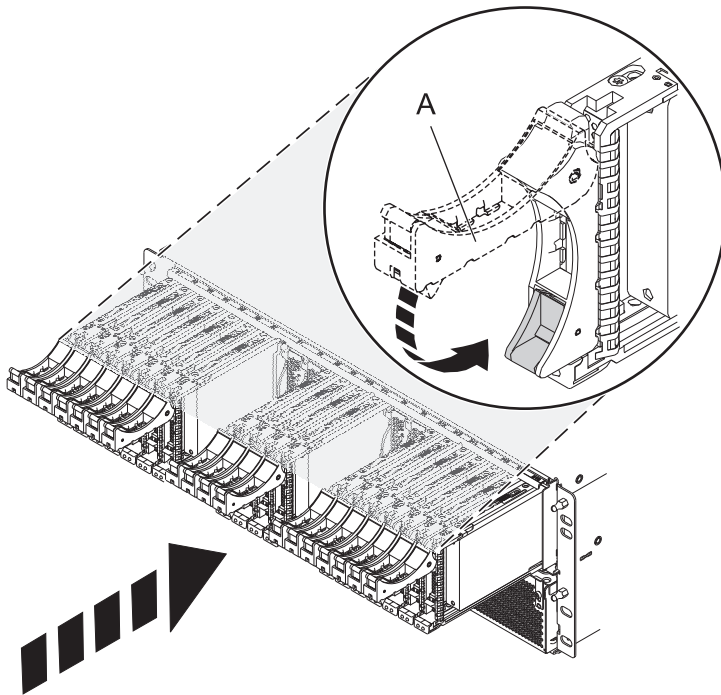

Figure 40. Installing the backplane filler on a rack-mounted model

5. Replace all disk drive units and fillers, if you removed them earlier.
  - a. Support the bottom of the disk drive unit as you align it with the guide rails in the backplane.
  - b. Slide the disk drive unit all the way into the backplane.
  - c. Move the handle (A) toward the disk drive unit to lock it into place.



6. Replace all expander cards and fillers, if you removed them earlier.
  - a. Supporting the bottom of the expander card with your hand, align it with the guide rails in the backplane.

- b. Slide the expander card all the way into the backplane.
- c. Move the handle (A) toward the card to lock it into place.

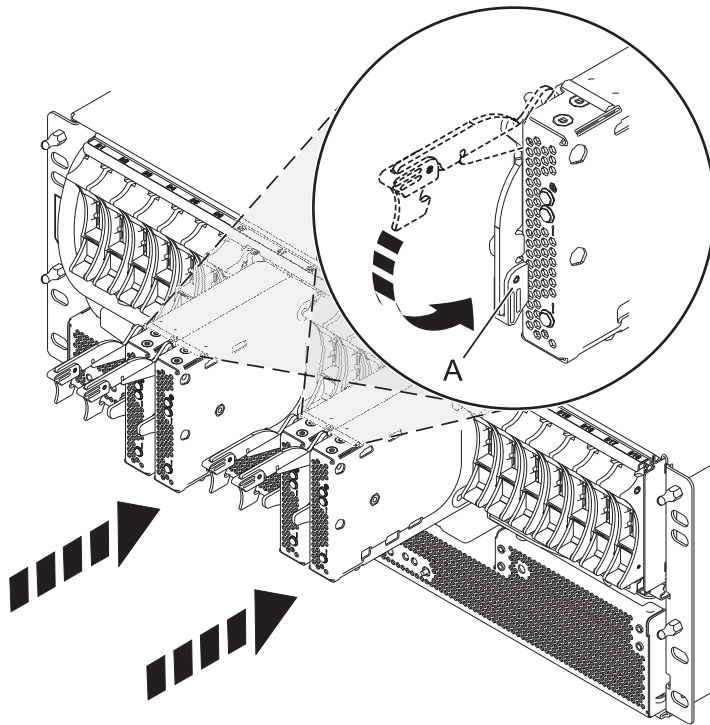

- 7. Connect the power cords to the back of the enclosure as shown in Figure 41.

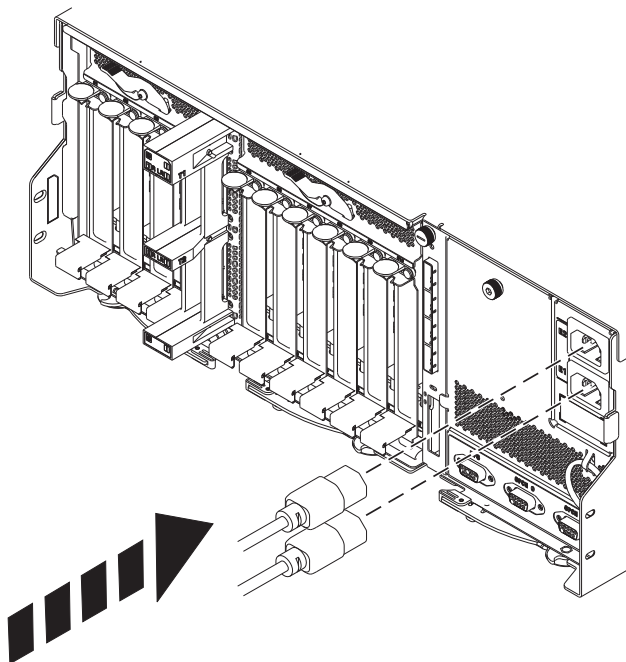

Figure 41. Connecting the power cords

- 8. Close the front rack door.

9. Place the system in the operating position. For instruction, see "Placing the rack-mounted system or expansion unit in the operating position" on page 71.
10. Start the system. See "Starting the system or logical partition" on page 46.
11. Verify the installed part. For instructions, see "Hardware service manager Verify option" on page 77.

---

## Chapter 5. Common procedures

This section contains the common procedures related to installing, removing, and replacing the backplane.

---

### Before you begin

Understand prerequisites for installing, removing, or replacing features and parts.

#### DANGER

When working on or around the system, observe the following precautions:

Electrical voltage and current from power, telephone, and communication cables are hazardous. To avoid a shock hazard:

- Connect power to this unit only with the IBM provided power cord. Do not use the IBM provided power cord for any other product.
- Do not open or service any power supply assembly.
- Do not connect or disconnect any cables or perform installation, maintenance, or reconfiguration of this product during an electrical storm.
- The product might be equipped with multiple power cords. To remove all hazardous voltages, disconnect all power cords.
- Connect all power cords to a properly wired and grounded electrical outlet. Ensure that the outlet supplies proper voltage and phase rotation according to the system rating plate.
- Connect any equipment that will be attached to this product to properly wired outlets.
- When possible, use one hand only to connect or disconnect signal cables.
- Never turn on any equipment when there is evidence of fire, water, or structural damage.
- Disconnect the attached power cords, telecommunications systems, networks, and modems before you open the device covers, unless instructed otherwise in the installation and configuration procedures.
- Connect and disconnect cables as described in the following procedures when installing, moving, or opening covers on this product or attached devices.

To Disconnect:

1. Turn off everything (unless instructed otherwise).
2. Remove the power cords from the outlets.
3. Remove the signal cables from the connectors.
4. Remove all cables from the devices

To Connect:

1. Turn off everything (unless instructed otherwise).
2. Attach all cables to the devices.
3. Attach the signal cables to the connectors.
4. Attach the power cords to the outlets.
5. Turn on the devices.

(D005)

#### DANGER

Observe the following precautions when working on or around your IT rack system:

- Heavy equipment—personal injury or equipment damage might result if mishandled.
- Always lower the leveling pads on the rack cabinet.
- Always install stabilizer brackets on the rack cabinet.
- To avoid hazardous conditions due to uneven mechanical loading, always install the heaviest devices in the bottom of the rack cabinet. Always install servers and optional devices starting from the bottom of the rack cabinet.
- Rack-mounted devices are not to be used as shelves or work spaces. Do not place objects on top of rack-mounted devices.



- Each rack cabinet might have more than one power cord. Be sure to disconnect all power cords in the rack cabinet when directed to disconnect power during servicing.
- Connect all devices installed in a rack cabinet to power devices installed in the same rack cabinet. Do not plug a power cord from a device installed in one rack cabinet into a power device installed in a different rack cabinet.
- An electrical outlet that is not correctly wired could place hazardous voltage on the metal parts of the system or the devices that attach to the system. It is the responsibility of the customer to ensure that the outlet is correctly wired and grounded to prevent an electrical shock.

#### CAUTION

- Do not install a unit in a rack where the internal rack ambient temperatures will exceed the manufacturer's recommended ambient temperature for all your rack-mounted devices.
- Do not install a unit in a rack where the air flow is compromised. Ensure that air flow is not blocked or reduced on any side, front, or back of a unit used for air flow through the unit.
- Consideration should be given to the connection of the equipment to the supply circuit so that overloading of the circuits does not compromise the supply wiring or overcurrent protection. To provide the correct power connection to a rack, refer to the rating labels located on the equipment in the rack to determine the total power requirement of the supply circuit.
- *(For sliding drawers.)* Do not pull out or install any drawer or feature if the rack stabilizer brackets are not attached to the rack. Do not pull out more than one drawer at a time. The rack might become unstable if you pull out more than one drawer at a time.
- *(For fixed drawers.)* This drawer is a fixed drawer and must not be moved for servicing unless specified by the manufacturer. Attempting to move the drawer partially or completely out of the rack might cause the rack to become unstable or cause the drawer to fall out of the rack.

(R001)

Before you begin a replacement or installation procedure, perform these tasks:

1. If you are installing a new feature, ensure that you have the software required to support the new feature.  
To do this, go to the following Web site: [http://www-912.ibm.com/e\\_dir/eServerPrereq.nsf](http://www-912.ibm.com/e_dir/eServerPrereq.nsf)
2. If you are performing an installation or replacement procedure that might put your data at risk, ensure, wherever possible, that you have a current backup of your system or logical partition (including operating systems, licensed programs, and data).
3. Review the installation or replacement procedure for the feature or part.
4. Note the significance of color on your system.

Blue or terra-cotta on a part of the hardware indicates a touch point where you can grip the hardware to remove it from or install it in the system, open or close a latch, and so on. Terra-cotta might also indicate that the part can be removed and replaced with the system or logical partition power on.

5. Ensure that you have access to a medium, flat-blade screwdriver, a Phillips screwdriver, and a pair of scissors.
6. If parts are incorrect, missing, or visibly damaged, do the following:
  - If you are replacing a part, contact the provider of your parts or next level of support.
  - If you are installing a feature, contact one of the following service organizations:
    - The provider of your parts or next level of support.
    - In the United States, the IBM Rochester Manufacturing Automated Information Line (R-MAIL) at 1-800-300-8751.

In countries and regions outside of the United States, use the following Web site to locate your service and support telephone numbers:

<http://www.ibm.com/planetwide>

7. If you encounter difficulties during the installation, contact your service provider, your IBM reseller, or your next level of support.
8. If you are installing new hardware in a logical partition, you need to understand and plan for the implications of partitioning your system. For information, see Logical Partitioning.

---

## Identifying a failing part

Use these instructions to learn how to locate and identify a failing part on your system or expansion unit using the appropriate method for your system.

### Identifying a failing part on an AIX system or logical partition

Use these instructions to learn how to locate a failing part, and then activate the indicator light for that part on a system or logical partition running the AIX<sup>®</sup> operating system.

#### Locating a failing part on an AIX system or logical partition

You might need to use AIX tools, before activating the indicator light, to locate a part that is failing.

1. Log in as root user or `celogin-`.
2. At the command line, type `diag` and press Enter.
3. From the Function Selection menu, select **Task Selection** and press Enter.
4. Select **Display Previous Diagnostic Results** and press Enter.
5. From the Display Previous Diagnostic Results display, select **Display Diagnostic Log Summary**. The Display Diagnostic Log display shows a chronological list of events.
6. Look in the **T** column for the most recent **S** entry. Select this row in the table and press Enter.
7. Select **Commit**. The details of this log entry are shown.
8. Record the location information and the SRN value shown near the end of the entry.
9. Exit to the command line.

Use the location information for the failing part to activate the indicator light that identifies the failing part. "Activating the indicator light for the failing part."

#### Activating the indicator light for the failing part

Use these instructions to help physically identify the location of a part you are servicing.

1. Log in as root user.
2. At the command line, type `diag` and press Enter.
3. From the Function Selection menu, select **Task Selection** and press Enter.
4. From the Task Selection menu, select **Identify and Attention Indicators** and press Enter.

5. From the list of lights, select the location code for the failing part and press Enter.
6. Select **Commit**. This turns on the system attention and indicator light for the failing part.
7. Exit to the command line.

## Identifying a failing part on an IBM i system or logical partition

You can activate or deactivate the indicator light by using IBM i to assist in locating a failing part.

### Activating the failing-part indicator light

You can search the service action log for an entry that matches the time, reference code, or resource of a problem, and then activate the indicator light for a failing part.

1. Sign on to an IBM i session, **with at least service level authority**.
2. On the command line of the session, type `strsst` and press Enter.

**Note:** If you cannot get to the System Service Tools display, use function 21 from the control panel. Alternatively, if the system is managed by a Hardware Management Console (HMC), use the Service Focal Point™ utilities to get to the Dedicated Service Tools (DST) display.

3. Type your service tools user ID and service tools password on the System Service Tools (SST) Sign On display. Press Enter.

**Remember:** The service tools password is case-sensitive.

4. Select **Start a service tool** from the System Service Tools (SST) display and press Enter.
5. Select **Hardware service manager** from the Start a Service Tool display and press Enter.
6. Select **Work with service action log** from the Hardware Service Manager display and press Enter.
7. On the Select Timeframe display, change the **From: Date and Time** field to a date and time prior to when the problem occurred.
8. Search for an entry that matches one or more conditions of the problem:
  - System Reference code
  - Resource
  - Date and time
  - Failing item list
9. Select option 2 (Display failing item information) to display the service action log entry.
10. Select option 2 (Display details) to display location information for the failing part to be replaced. The information displayed in the date and time fields is the date and time for the first occurrence of the specific System reference code for the resource displayed during the time range selected.
11. If location information is available, select option 6 (Indicator on) to turn on the failing part's indicator light.

**Tip:** If the failing part does not contain a physical indicator light, a higher-level indicator light is activated. For example, the indicator light for the backplane or unit that contains the failing part might be lit. In this case, use the location information to locate the actual failing part.

12. Look for the enclosure indicator light to locate the enclosure that contains the failing part.

### Deactivating the failing-part indicator light

Use this procedure to turn off any indicator light that you turned on as a part of a service action.

To deactivate the indicator light, follow these steps:

1. Select option 7 (Indicator off) to turn off the indicator light.
2. Select the **Acknowledge all errors** function at the bottom of the Service Action Log display, if all problems have been resolved.
3. Close the log entry by selecting option 8 (Close new entry) on the Service Action Log Report display.

## Identifying a failing part on a Linux system or logical partition

If the service aids have been installed on a system or logical partition, you can activate or deactivate the indicator lights to locate a part or complete a service action.

### Locating a failing part on a Linux system or logical partition

If the service aids have been installed on a system or logical partition, you need to activate the indicator lights to locate a part.

### Finding the location code of a failing part in a Linux system or logical partition

To retrieve the location code of the failing part, if you do not know the location code, use the procedure in this topic.

To locate the failing part in a system or logical partition follow these steps:

1. Log in as root user.
2. At the command line, type `grep diagela /var/log/platform` and press Enter.
3. Look for the most recent entry that contains a system reference code (SRC).
4. Record the location information.

### Activating the indicator light for the failing part

If you know the location code of the failing part, activate the indicator light to help you locate which part to replace.

To activate the indicator light, follow these steps:

1. Log in as root user.
2. At the command line, type `/usr/sbin/usysident -s identify -l<location code>` and press Enter.
3. Look for the system attention light to identify the enclosure that contains the failing part.

### Deactivating the failing-part indicator light

After you complete a removal and replacement procedure, you must deactivate the failing-part indicator light.

To deactivate the indicator light, follow these steps:

1. Log in as root user.
2. At the command line, type `/usr/sbin/usysident -s normal -l<location code>` and press Enter.

## Locating a failing part in a Virtual I/O Server system or logical partition

You can use Virtual I/O Server (VIOS) tools, before activating the indicator light, to locate a part that is failing.

1. Log in as root user or `celogin-`.
2. At the command line, type `diagmenu` and press Enter.
3. From the **Function Selection** menu, select **Task Selection** and press Enter.
4. Select **Display Previous Diagnostic Results** and press Enter.
5. From the **Display Previous Diagnostic Results** display, select **Display Diagnostic Log Summary**. A **Display Diagnostic Log** display appears. This display contains a chronological list of events.
6. Look in the **T** column for the most recent **S** entry. Select this row in the table and press Enter.
7. Choose **Commit**. The details of this log entry are shown.
8. Record the location information and the SRN value shown near the end of the entry.
9. Exit to the command line.

Use the location information for the failing part to activate the indicator light that identifies the failing part. For instructions, see Identifying a part using the Virtual I/O Server.

## Identifying a part using the Virtual I/O Server

Use these instructions to turn on the indicator light to help you physically locate a part using the Virtual I/O Server (VIOS).

1. Log in as root user.
2. At the command line, type `diagmenu` and press Enter.
3. From the Function Selection menu, select **Task Selection**. Press Enter.
4. From the Task Selection menu, select **Identify and Attention Indicators**. Press Enter.
5. From the list of lights, select the location code for the failing part and press Enter.
6. Select **Commit**. This turns on the system attention and indicator light for the failing part.
7. Exit to the command line.

---

## Starting the system or logical partition

Learn how to start a system or logical partition after performing a service action or system upgrade.

### Starting a system that is not managed by a Hardware Management Console

You can use the power button or the Advanced System Management Interface to start a system that is not managed by a Hardware Management Console.

To start a system that is not managed by a Hardware Management Console (HMC), follow these steps:

1. On a rack-mounted system unit, open the front rack door, if necessary. On a stand-alone system unit, open the front door.
2. Before you press the power button on the control panel, ensure that power is connected to the system unit as follows:
  - All system power cables are connected to a power source.
  - The power-on light, as shown in the following figure, is slowly flashing.
  - The top of the display, as shown in the following figure, shows 01 V=F.

**Tip:** The system attention light, as shown in the following figure, does not appear on the control panel on the model 9117-MMA.

3. Press the power button (**A**), as shown in the following figure, on the control panel.

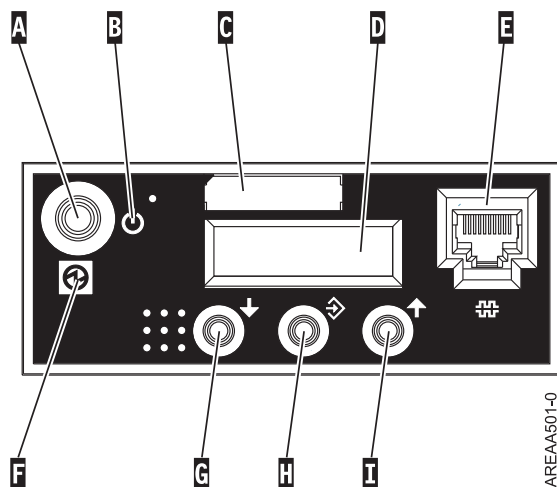

Figure 42. 570 control panel

- **A:** Power-on button
- **B:** On/off power symbol
- **C:** Serial number label
- **D:** Function/Data display
- **E:** System port (S1)
- **F:** Power LED
  - A flashing light indicates standby power to the unit.
  - A constant light indicates full system power to the unit.

**Note:** There is approximately a 30 second transition period from the time the power-on button is pressed to when the power LED goes from flashing to solid. During the transition period, you might observe the flashing intervals speed up.

- **G:** Decrement button
- **H:** Enter button
- **I:** Increment button

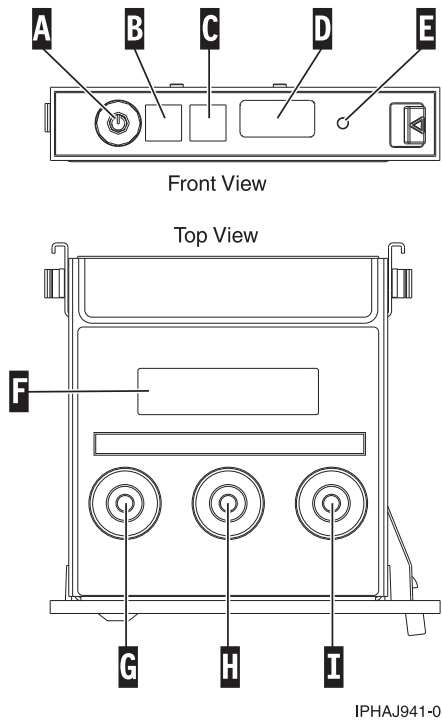

Figure 43. Control panel for the 8203-E4A, 8261-E4S, 8204-E8A, 9407-M15, 9408-M25, and 9409-M50.

- **A:** Power-on button
- **B:** Power LED
  - A flashing light indicates standby power to the unit.
  - A constant light indicates full system power to the unit.

**Note:** There is approximately a 30 second transition period from the time the power-on button is pressed to when the power LED goes from flashing to solid. During the transition period, you might observe the LED flashing faster.

- **C:** Attention light
- **D:** USB port

- E: Pinhole reset button
  - F: Function/Data display
  - G: Decrement button
  - H: Enter button
  - I: Increment button
4. Observe the following after pressing the power button:
- The power-on light begins to flash faster.
  - The system cooling fans are activated after approximately 30 seconds and begin to accelerate to operating speed.
  - Progress indicators, also referred to as checkpoints, appear on the control panel display while the system is being started. The power-on light on the control panel stops flashing and remains on, indicating that system power is on.

**Tip:** If pressing the power button does not start the system, do the following steps to start the system using the Advanced System Management Interface (ASMI):

1. Set up access to the ASMI. For instructions, see *Accessing the ASMI*.
2. Start the system using the ASMI. For instructions, see *Powering the system on and off*.

## Starting a system or logical partition using the Hardware Management Console

You can use the Hardware Management Console (HMC) user interface to start the system or logical partition after the required cables are installed and the power cables are connected to a power source.

For instructions on working with the HMC, see *Managing the Hardware Management Console*. For instructions on starting a logical partition, see *Logical partitioning*. For instructions on starting the system, see *Powering on the managed system*.

Progress indicators, also referred to as checkpoints, appear on the control panel display while the system is being started. When the power-on light on the control panel stops blinking and remains on, the system power is on.

---

## Stopping a system or logical partition

Learn how to stop a system or logical partition as a part of a system upgrade or service action.

**Attention:** Using either the power-on button on the control panel or entering commands at the Hardware Management Console (HMC) to stop the system can cause unpredictable results in the data files. Also, the next time you start the system, it might take longer if all applications are not ended before stopping the system.

To stop the system or logical partition, select the appropriate procedure.

## Stopping a system that is not managed by a Hardware Management Console

You might need to stop the system to perform another task. Use these instructions to stop the system using the power button or Advanced System Management Interface.

Before you stop the system, follow these steps:

1. If an Integrated xSeries<sup>®</sup> Adapter (IXA) is present on the system, shut it down using IBM i options.
2. Ensure that all jobs are completed and end all applications.
3. Ensure that the operating system is stopped.

**Attention:** Failure to do so can result in the loss of data.

4. Record the IPL type and IPL mode from the control panel display to help you return the system to this state when the installation or replacement procedure is completed.

The following procedure describes how to stop a system that is not managed by a Hardware Management Console (HMC).

1. Log in to the system as a user with the authority to run the shutdown or pwrdownsys (Power Down System) command.
2. At the command line, enter one of the following commands:
  - If your system is running the AIX operating system, type **shutdown**.
  - If your system is running the Linux operating system, type **shutdown -h now**.
  - If your system is running the IBM i operating system, type **pwrdownsys**. If your system is partitioned, use the pwrdownsys command to power down each of the secondary partitions. Then, use the pwrdownsys command to power down the primary partition.

The command stops the operating system. The system power turns off, the power-on light begins to slowly blink, and the system goes into a standby state.

3. Set the power switches of any devices connected to the system to off.
4. Unplug any power cables that are attached to the unit from electrical outlets. Ensure that you unplug power cables from peripheral devices, such as printers and expansion units.

**Important:** The system might be equipped with a second power supply. Before continuing with this procedure, ensure that all power sources to the system have been completely disconnected.

(L003)

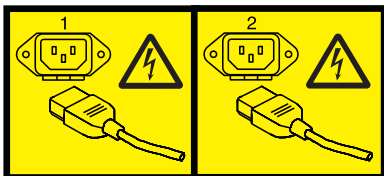

or



## Stopping a system by using the Hardware Management Console

You can use the Hardware Management Console (HMC) user interface to stop the system or a logical partition. Use the following steps to accomplish this task.

By default, the managed system is set to power off automatically when you shut down the last running logical partition on the managed system. If you set the managed system properties on the HMC so that the managed system does not power off automatically, you must use this procedure to power off your managed system.

**Attention:** If possible, shut down the running logical partitions on the managed system before powering off the managed system. Powering off the managed system without shutting down the logical partitions first causes the logical partitions to shut down abnormally and can cause data loss. If you use a Virtual I/O Server (VIOS) logical partition, ensure that all clients are shut down or that the clients have access to their devices using an alternate method.

To power off a managed system, you must be a member of one of the following roles:

- Super administrator
  - Service representative
  - Operator
  - Product engineer
1. In the Navigation area, expand the **Systems Management** folder.
  2. Click the **Servers** icon.
  3. In the Contents area, select the managed system.
  4. Select **Tasks**, then **Operations**, and then **Power Off**
  5. Select the appropriate power-off mode and click **OK**.

## Related information

 Shutting down and restarting logical partitions

---

## Disconnecting the SMP processor cable from a system

You might need to disconnect this cable to add or remove memory or processors. Use the procedure in this section to accomplish this task.

### DANGER

When working on or around the system, observe the following precautions:

Electrical voltage and current from power, telephone, and communication cables are hazardous. To avoid a shock hazard:

- Connect power to this unit only with the IBM provided power cord. Do not use the IBM provided power cord for any other product.
- Do not open or service any power supply assembly.
- Do not connect or disconnect any cables or perform installation, maintenance, or reconfiguration of this product during an electrical storm.
- The product might be equipped with multiple power cords. To remove all hazardous voltages, disconnect all power cords.
- Connect all power cords to a properly wired and grounded electrical outlet. Ensure that the outlet supplies proper voltage and phase rotation according to the system rating plate.
- Connect any equipment that will be attached to this product to properly wired outlets.
- When possible, use one hand only to connect or disconnect signal cables.
- Never turn on any equipment when there is evidence of fire, water, or structural damage.
- Disconnect the attached power cords, telecommunications systems, networks, and modems before you open the device covers, unless instructed otherwise in the installation and configuration procedures.
- Connect and disconnect cables as described in the following procedures when installing, moving, or opening covers on this product or attached devices.

#### To Disconnect:

1. Turn off everything (unless instructed otherwise).
2. Remove the power cords from the outlets.
3. Remove the signal cables from the connectors.
4. Remove all cables from the devices

#### To Connect:

1. Turn off everything (unless instructed otherwise).
2. Attach all cables to the devices.
3. Attach the signal cables to the connectors.
4. Attach the power cords to the outlets.
5. Turn on the devices.

(D005)

To disconnect an SMP processor cable connection from a system, complete the following steps:

1. If necessary, open the front door of the rack.
2. Disconnect the power source from the system by unplugging the system.

**Note:** This system can be equipped with a second power supply. Before continuing with this procedure, ensure that the power source to the system has been completely disconnected.

(L003)

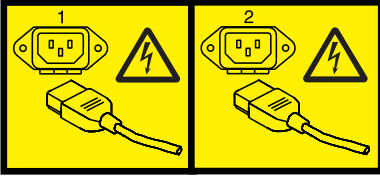

OR

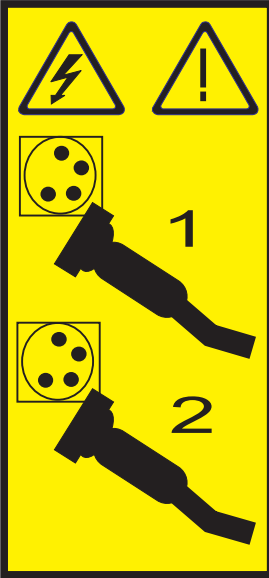

3. Remove the front cover. For instructions, see “Removing the front cover from the 8234-EMA, 9117-MMA, or 9406-MMA” on page 65.
4. Remove the left edge of the trim kit on the system rack to expose the left edge of the SMP processor cable.

**Attention:**

Attach a wrist strap to an unpainted metal surface of your hardware to prevent electrostatic discharge from damaging your hardware.

When using a wrist strap, follow all electrical safety procedures. A wrist strap is for static control. It does not increase or decrease your risk of receiving electric shock when using or working on electrical equipment.

If you do not have a wrist strap, just prior to removing the product from ESD packaging and installing or replacing hardware, touch an unpainted metal surface of the system for a minimum of 5 seconds.

5. Unlatch the plastic fastener (A), as shown in the following figure.
6. Lift the latch handle (B) until the connector is unseated.

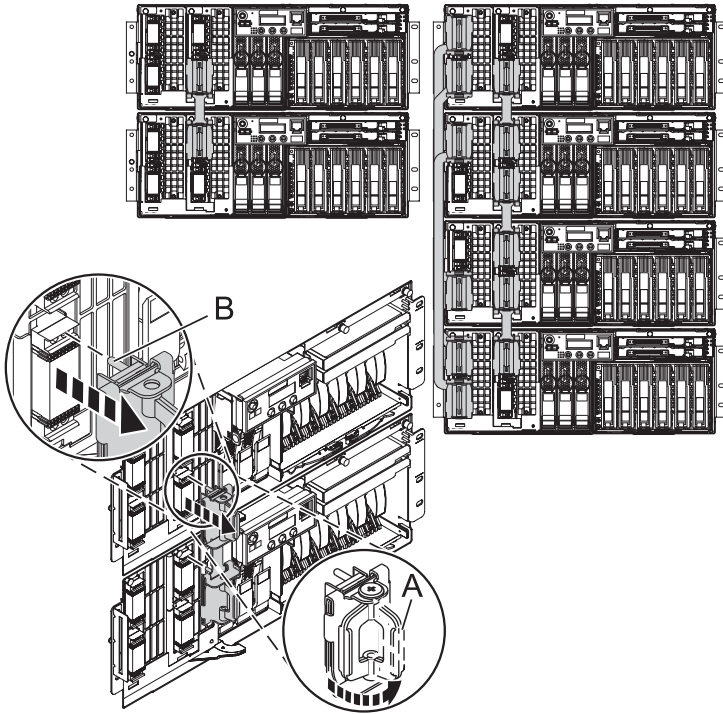

7. Carefully pull the connector from the system.
8. When the guide pins are free, carefully pull the cable away from the system unit.

---

## Reconnecting the SMP processor cable to a system

You might need to reconnect this cable after adding or removing memory or processors. Use the procedure in this section to accomplish this task.

### DANGER

When working on or around the system, observe the following precautions:

Electrical voltage and current from power, telephone, and communication cables are hazardous. To avoid a shock hazard:

- Connect power to this unit only with the IBM provided power cord. Do not use the IBM provided power cord for any other product.
- Do not open or service any power supply assembly.
- Do not connect or disconnect any cables or perform installation, maintenance, or reconfiguration of this product during an electrical storm.
- The product might be equipped with multiple power cords. To remove all hazardous voltages, disconnect all power cords.
- Connect all power cords to a properly wired and grounded electrical outlet. Ensure that the outlet supplies proper voltage and phase rotation according to the system rating plate.
- Connect any equipment that will be attached to this product to properly wired outlets.
- When possible, use one hand only to connect or disconnect signal cables.
- Never turn on any equipment when there is evidence of fire, water, or structural damage.
- Disconnect the attached power cords, telecommunications systems, networks, and modems before you open the device covers, unless instructed otherwise in the installation and configuration procedures.
- Connect and disconnect cables as described in the following procedures when installing, moving, or opening covers on this product or attached devices.

To Disconnect:

1. Turn off everything (unless instructed otherwise).
2. Remove the power cords from the outlets.
3. Remove the signal cables from the connectors.
4. Remove all cables from the devices

To Connect:

1. Turn off everything (unless instructed otherwise).
2. Attach all cables to the devices.
3. Attach the signal cables to the connectors.
4. Attach the power cords to the outlets.
5. Turn on the devices.

(D005)

To connect an SMP processor cable to a single system, complete the following steps:

1. Perform prerequisite tasks as described in “Before you begin” on page 41.
2. Stop all system units. Refer to Stopping a system or logical partition.
3. If necessary, open the front rack door.
4. Disconnect the power source from the system by unplugging the system.

**Note:** This system can be equipped with a second power supply. Before continuing with this procedure, ensure that the power source to the system has been completely disconnected.

(L003)

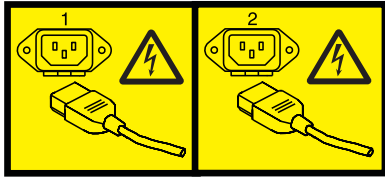

or



5. If necessary, remove the left edge of the trim kit on the system rack.

**Attention:**

- Attach a wrist strap to an unpainted metal surface of your hardware to prevent electrostatic discharge (ESD) from damaging your hardware.
  - When using a wrist strap, follow all electrical safety procedures. A wrist strap is for static control. It does not increase or decrease your risk of receiving electric shock when using or working on electrical equipment.
  - If you do not have a wrist strap, just prior to removing the product from ESD packaging and installing or replacing hardware, touch an unpainted metal surface of the system for a minimum of 5 seconds.
6. Lift the latch handle (C) to the open position.

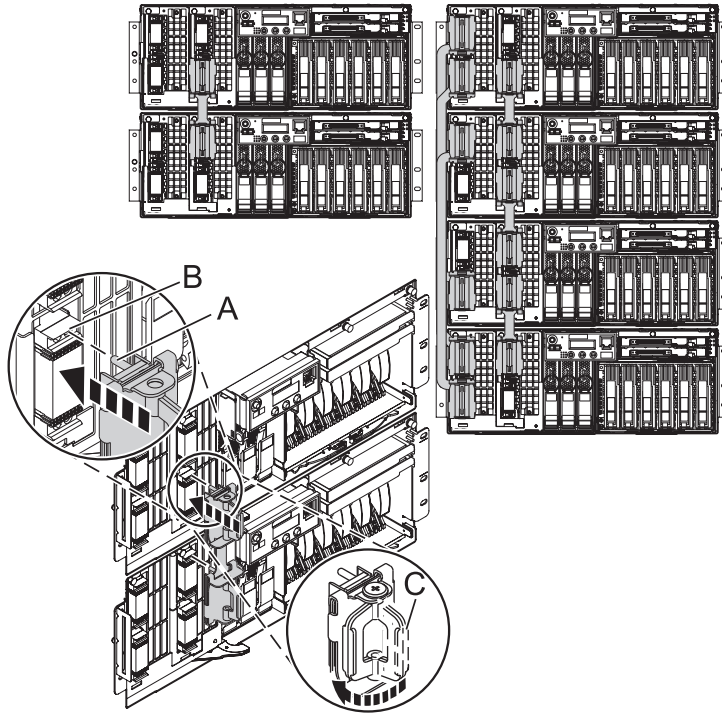

7. Align the guide pins (A) with the connector (B) on the system.
8. Carefully push the cable connector into the system connection.

**Note:** Evenly press the connector in place, using firm straight pressure on both the top and bottom of each cable-end. At the same time, press evenly at the top and bottom of each cable-end. Use the SMP tool to seat the cable as shown in the following figure.

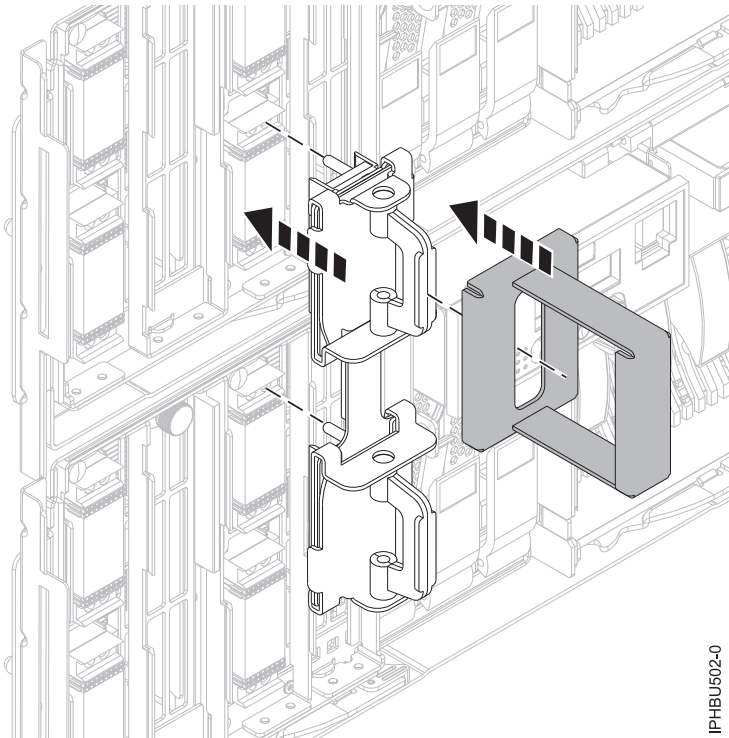

IPHBU502-0

Figure 44. Using the SMP cable tool

9. Push the latch handle down to seat the pins.
10. Replace the left edge of the trim kit.
11. Install the front cover. For instructions, see “Installing the front cover on the 8234-EMA, 9117-MMA, or 9406-MMA” on page 66.
12. Close the front rack door.

---

## Removing and replacing covers and doors

Use these instructions to remove, replace, or install covers to access components or perform service.

### Removing the service access cover from a rack-mounted 8203-E4A, 8204-E8A, 8261-E4S, 9407-M15, 9408-M25, or 9409-M50

Use this procedure to remove the service access cover to perform service or to gain access to internal components.

1. Place the system into the service position. For instructions, see “Placing a rack-mounted 8203-E4A, 8204-E8A, 8261-E4S, 9407-M15, 9408-M25, or 9409-M50 in the service position” on page 72.
2. Loosen the two thumbscrews **(A)** located at the back of the cover.
3. Slide the cover **(B)** toward the back of the system unit. When the front of the service access cover clears the upper frame ledge, lift the cover up and off the system unit.

**Attention:** For proper cooling and airflow, install the cover before starting the system. Operating the system without the cover for more than 30 minutes could damage the system components.

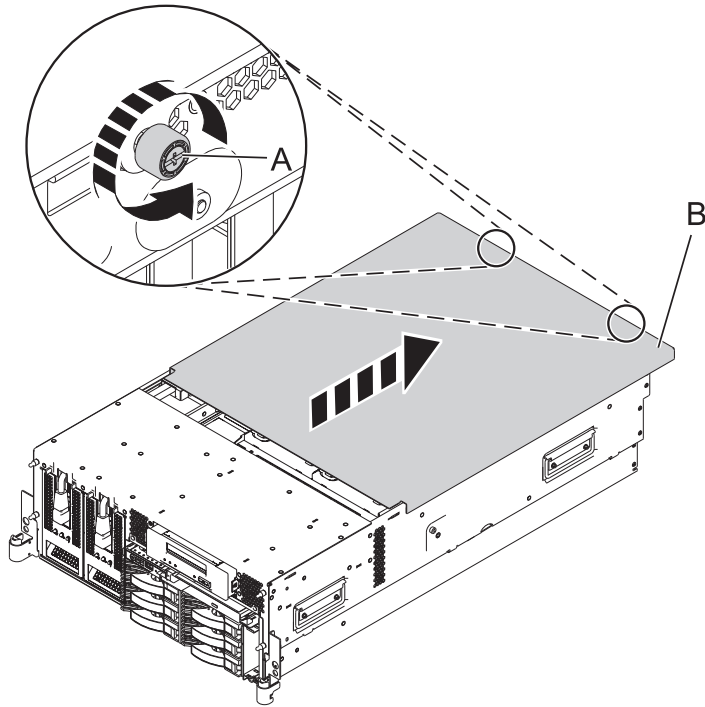

Figure 45. Remove the service access cover from a rack-mounted model

## Installing the service access cover on a rack-mounted 8203-E4A, 8204-E8A, 8261-E4S, 9407-M15, 9408-M25, or 9409-M50

Use this procedure to install the service access cover after performing service or accessing internal components.

1. Place the service access cover (A) on the top of the system unit, approximately 25 mm (1 in.) from the front of the system unit.
2. Hold the service access cover against the system unit, and slide it toward the front of the system.  
The tabs on the service access cover slide beneath the upper chassis ledge, and the two thumbscrews align with the screw holes at the back of the system unit.
3. Tighten the thumbscrews (B) located at the back of the cover.

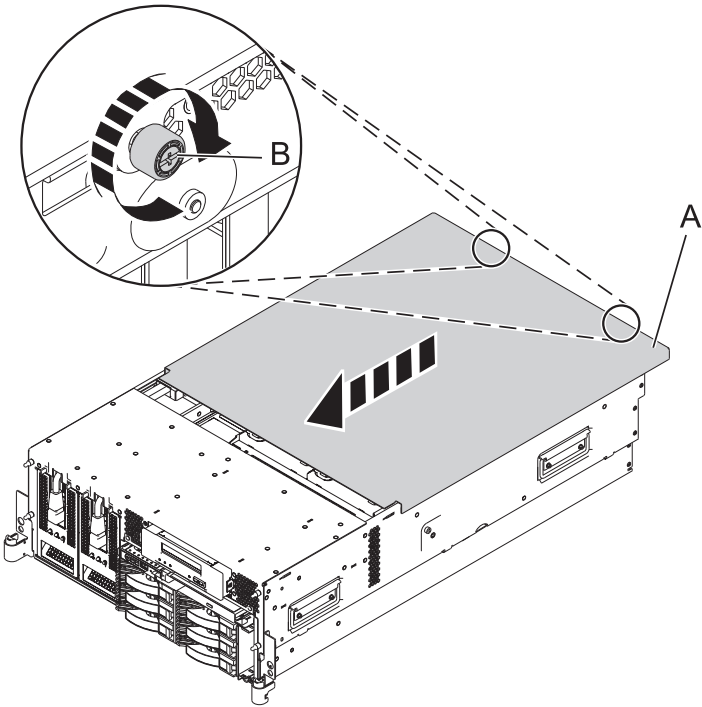

Figure 46. Install the service access cover on the rack-mounted model

## Removing the service access cover from a stand-alone 8203-E4A, 8204-E8A, 8261-E4S, 9407-M15, 9408-M25, or 9409-M50

Use this procedure to remove the service access cover to perform service or to gain access to internal components.

To remove the service access cover from a stand-alone model, do the following steps:

1. Loosen the two thumbscrews (A) located at the back of the service access cover as shown in the following figure.
2. Slide the service access cover (B) toward the back of the system. When the front of the cover clears the front frame ledge, lift the cover off the system.

**Attention:** For proper cooling and airflow, install the cover before starting the system. Operating the system without the cover for more than 30 minutes might damage the system components.

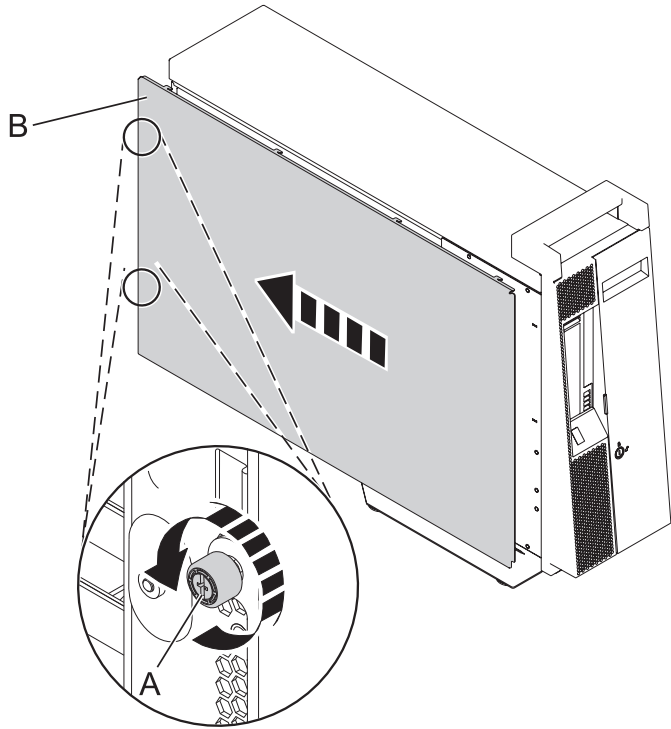

Figure 47. Removing the service access cover from the stand-alone model

### Installing the service access cover on a stand-alone 8203-E4A, 8204-E8A, 8261-E4S, 9407-M15, 9408-M25, or 9409-M50

Use this procedure to install the service access cover after performing service or accessing internal components.

1. Align the service access cover pins with the slots in the system. The flanges on the top and bottom of the cover wrap around the system frame.
2. Hold the service access cover against the system unit (A) and slide it toward the front of the system.
3. Tighten the two thumbscrews (B) located at the back of the cover.

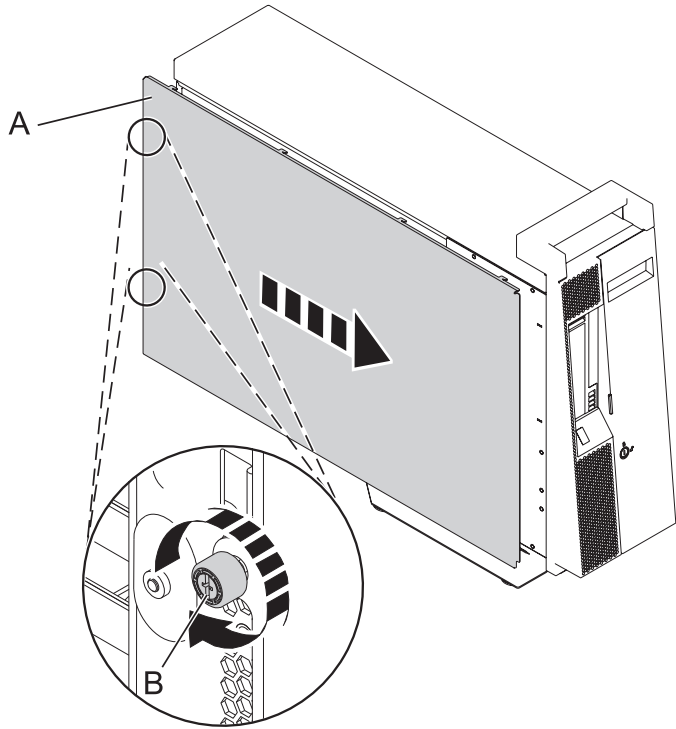

Figure 48. Installing the service access cover on a stand-alone model

### Removing the front cover from a rack-mounted 8203-E4A, 8204-E8A, 8261-E4S, 9407-M15, 9408-M25, or 9409-M50

Use this procedure to remove the cover to access components or perform service.

1. Remove the two thumbscrews (A) that secure the system to the rack (B) as shown in the following figure.
2. Push in the release latches (C) and pull the cover away from the system.

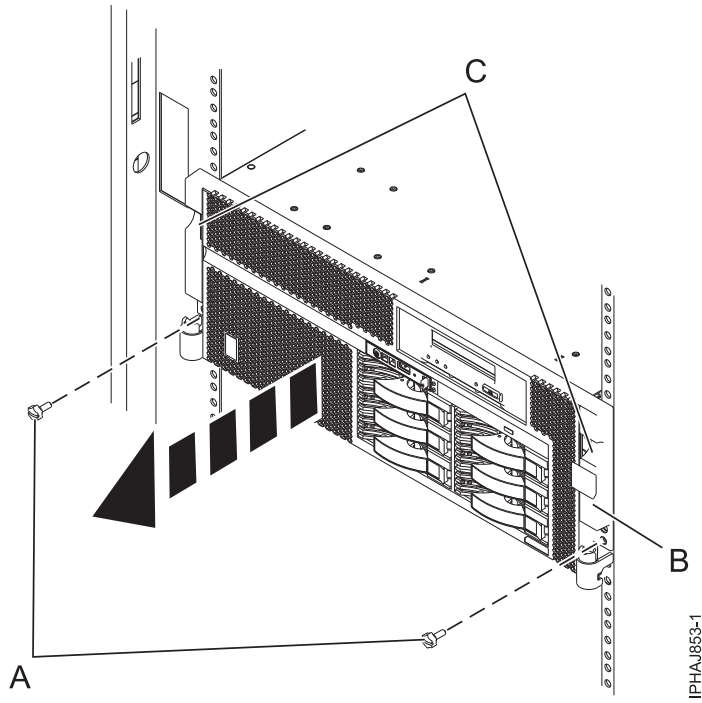

Figure 49. Removing the front cover from a rack-mounted model

### Installing the front cover on a rack-mounted 8203-E4A, 8204-E8A, 8261-E4S, 9407-M15, 9408-M25, or 9409-M50

Use this procedure to install the cover after accessing components or performing service.

1. Push in the release latches (B) and push the cover onto the system.
2. Gently push the cover in until the two cover-release latches (B) are seated in their respective slots as shown in the following figure.
3. Replace the two thumbscrews (C) that secure the system to the rack (A).

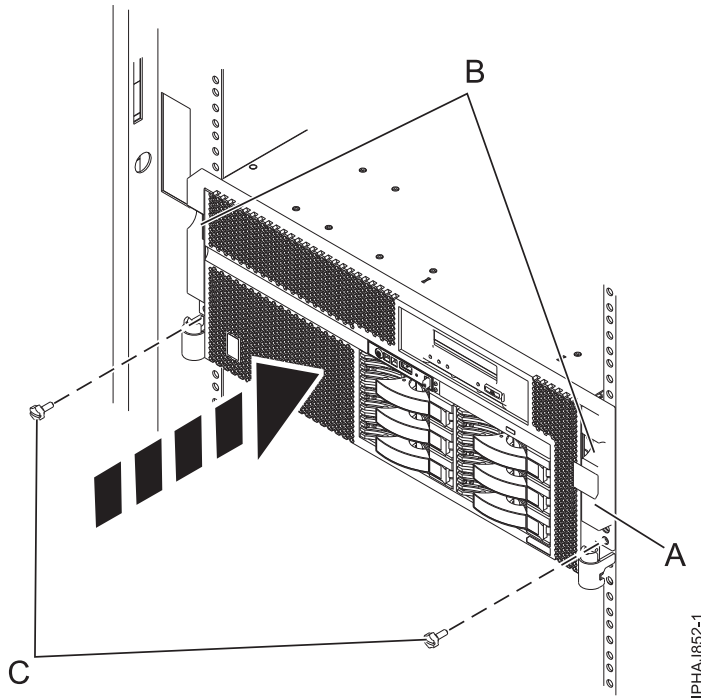

Figure 50. Installing the front cover on a rack-mounted model

## Removing the door from the 8204-E8A or 9409-M50

Use this procedure to remove the door to access components or perform service.

1. Open the front door by grasping the door handle and pulling the door out and away from the system unit.
2. To remove the door, press down on the top back edge of the door.
3. Gently swivel the top back edge of the door forward and out past the top of the system unit.
4. Lift the door up to release it from the lower retaining post.

## Installing or replacing the door on the 8204-E8A or 9409-M50

Use this procedure to install the door after accessing components or performing service.

1. Set the door on the lower retaining post.
2. Rotate the door toward the top of the system unit.
3. Press down on the lower back edge of the door, and seat the top post into its matching slot.
4. Close and secure the door.

## Removing the front cover from the stand-alone 8203-E4A, 8204-E8A, 8261-E4S, 9407-M15, 9408-M25, or 9409-M50

Use this procedure to remove the cover to access components or perform service.

1. Open the door that covers the disk drives by unlocking and pulling the door open.
2. Press down on the cover-release tab (A) as shown in the following figure.
3. Pull the top of the cover (B) out and away from the system.

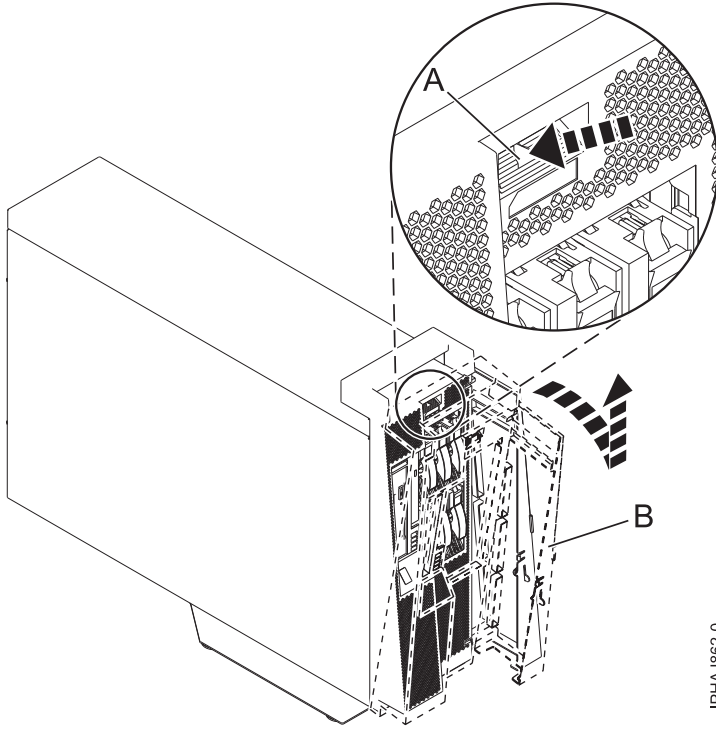

IPHAJ862-0

Figure 51. Remove the door from the model

4. Gently pull the cover up and off the base.

### **Installing the front cover on a stand-alone 8203-E4A, 8204-E8A, 8261-E4S, 9407-M15, 9408-M25, or 9409-M50**

Use this procedure to install the cover after accessing components or performing service.

1. Place the two lower cover-locking tabs into the retaining slots located on the base of the system unit as shown in the following figure.

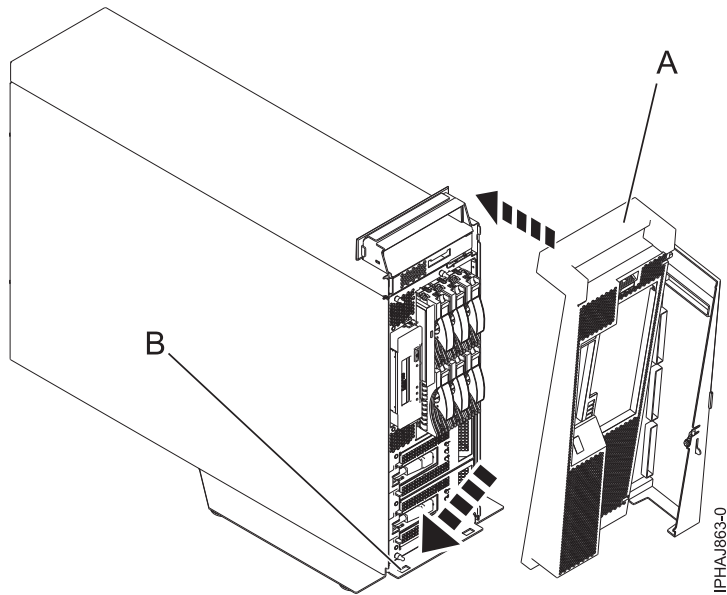

Figure 52. Replacing the cover on the model

2. Push the cover up toward the top of the system (A), ensuring that the aligning pins are aligned with their matching slots (B) located on the system.
3. Gently push the cover in until the cover-release tab snaps into place.
4. Close and secure the door.

## Removing and replacing the front cover for the 8234-EMA, 9117-MMA, or 9406-MMA

Use these procedures to remove and replace the cover to access components or perform service.

### Removing the front cover from the 8234-EMA, 9117-MMA, or 9406-MMA

Use this procedure to remove the cover to access components or perform service.

To remove the front cover follow these steps:

1. If necessary, open the front rack door.
2. Loosen the thumbscrew on the right side of the cover as shown in the following figure.

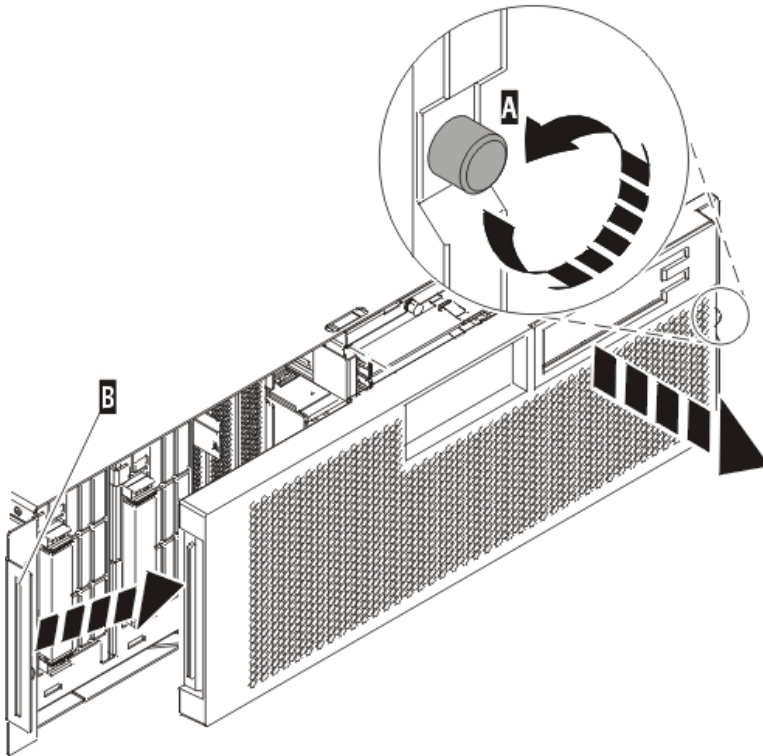

IPHAIF01-1

Figure 53. Removing the front cover

3. Slide the cover to the right, and remove it from the system unit.

### **Installing the front cover on the 8234-EMA, 9117-MMA, or 9406-MMA**

Use this procedure to install the cover after accessing components or performing service.

To install the front cover follow these steps:

1. Position the cover on the front of the system unit so that the tab on the left side of the cover is in the matching slot on the left side of the system unit as shown in the following figure.

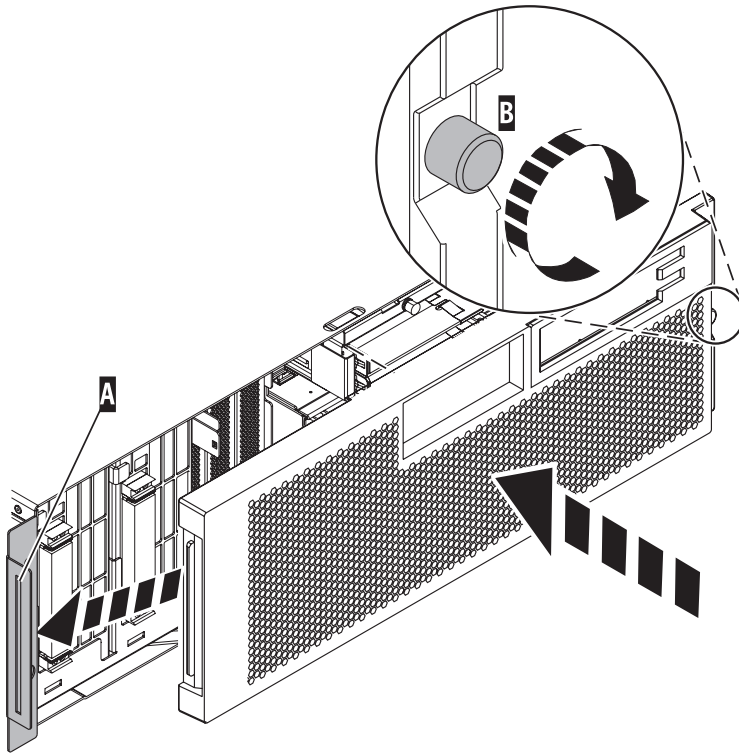

IPHAJ500-1

Figure 54. Installing the front cover

2. Tighten the thumbscrew on the right side of the cover.
3. Close the front rack door.

---

## Placing the rack-mounted system or expansion unit in the service position or operating position

Use these procedures to place a system or expansion unit into the service position or operating position to perform service or to gain access to internal components.

### Placing the rack-mounted system or expansion unit in the service position

Use this procedure to perform service or gain access to internal components by placing the rack-mounted system or expansion unit in the service position.

**Note:** Some of the figures in these procedures might not look exactly like the system or expansion unit that you have. However, the steps to perform the task are the same.

## DANGER

When working on or around the system, observe the following precautions:

Electrical voltage and current from power, telephone, and communication cables are hazardous. To avoid a shock hazard:

- Connect power to this unit only with the IBM provided power cord. Do not use the IBM provided power cord for any other product.
- Do not open or service any power supply assembly.
- Do not connect or disconnect any cables or perform installation, maintenance, or reconfiguration of this product during an electrical storm.
- The product might be equipped with multiple power cords. To remove all hazardous voltages, disconnect all power cords.
- Connect all power cords to a properly wired and grounded electrical outlet. Ensure that the outlet supplies proper voltage and phase rotation according to the system rating plate.
- Connect any equipment that will be attached to this product to properly wired outlets.
- When possible, use one hand only to connect or disconnect signal cables.
- Never turn on any equipment when there is evidence of fire, water, or structural damage.
- Disconnect the attached power cords, telecommunications systems, networks, and modems before you open the device covers, unless instructed otherwise in the installation and configuration procedures.
- Connect and disconnect cables as described in the following procedures when installing, moving, or opening covers on this product or attached devices.

To Disconnect:

1. Turn off everything (unless instructed otherwise).
2. Remove the power cords from the outlets.
3. Remove the signal cables from the connectors.
4. Remove all cables from the devices

To Connect:

1. Turn off everything (unless instructed otherwise).
2. Attach all cables to the devices.
3. Attach the signal cables to the connectors.
4. Attach the power cords to the outlets.
5. Turn on the devices.

(D005)

## DANGER

Observe the following precautions when working on or around your IT rack system:

- Heavy equipment—personal injury or equipment damage might result if mishandled.
- Always lower the leveling pads on the rack cabinet.
- Always install stabilizer brackets on the rack cabinet.
- To avoid hazardous conditions due to uneven mechanical loading, always install the heaviest devices in the bottom of the rack cabinet. Always install servers and optional devices starting from the bottom of the rack cabinet.
- Rack-mounted devices are not to be used as shelves or work spaces. Do not place objects on top of rack-mounted devices.



- Each rack cabinet might have more than one power cord. Be sure to disconnect all power cords in the rack cabinet when directed to disconnect power during servicing.
- Connect all devices installed in a rack cabinet to power devices installed in the same rack cabinet. Do not plug a power cord from a device installed in one rack cabinet into a power device installed in a different rack cabinet.
- An electrical outlet that is not correctly wired could place hazardous voltage on the metal parts of the system or the devices that attach to the system. It is the responsibility of the customer to ensure that the outlet is correctly wired and grounded to prevent an electrical shock.

#### CAUTION

- Do not install a unit in a rack where the internal rack ambient temperatures will exceed the manufacturer's recommended ambient temperature for all your rack-mounted devices.
- Do not install a unit in a rack where the air flow is compromised. Ensure that air flow is not blocked or reduced on any side, front, or back of a unit used for air flow through the unit.
- Consideration should be given to the connection of the equipment to the supply circuit so that overloading of the circuits does not compromise the supply wiring or overcurrent protection. To provide the correct power connection to a rack, refer to the rating labels located on the equipment in the rack to determine the total power requirement of the supply circuit.
- *(For sliding drawers.)* Do not pull out or install any drawer or feature if the rack stabilizer brackets are not attached to the rack. Do not pull out more than one drawer at a time. The rack might become unstable if you pull out more than one drawer at a time.
- *(For fixed drawers.)* This drawer is a fixed drawer and must not be moved for servicing unless specified by the manufacturer. Attempting to move the drawer partially or completely out of the rack might cause the rack to become unstable or cause the drawer to fall out of the rack.

(R001)

To place a rack-mounted system or expansion unit into the service position, follow these steps:

1. If necessary, open the front rack door.
2. Remove the two thumbscrews (A) that secure the system or expansion unit (B) to the rack as shown in the following figure.

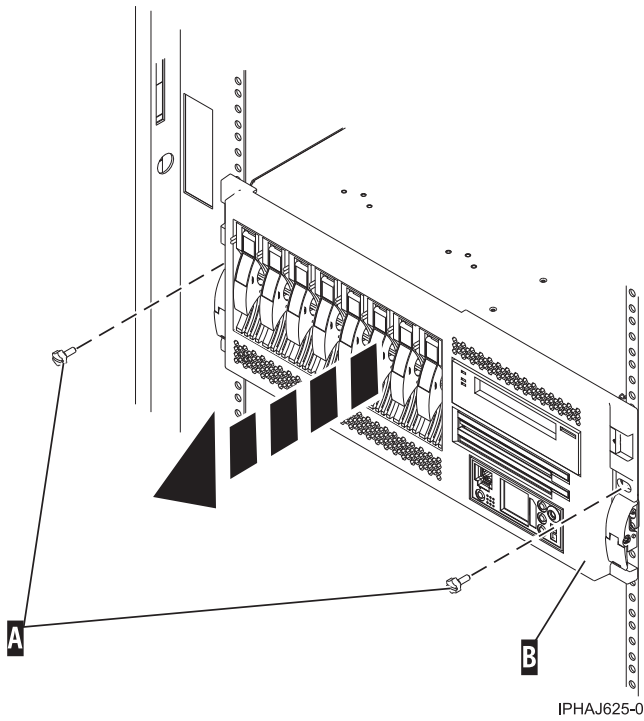

Figure 55. Removing the thumbscrews from the system and rack

3. Release the rack latches (A) on both the left and right sides as shown in the following figure.

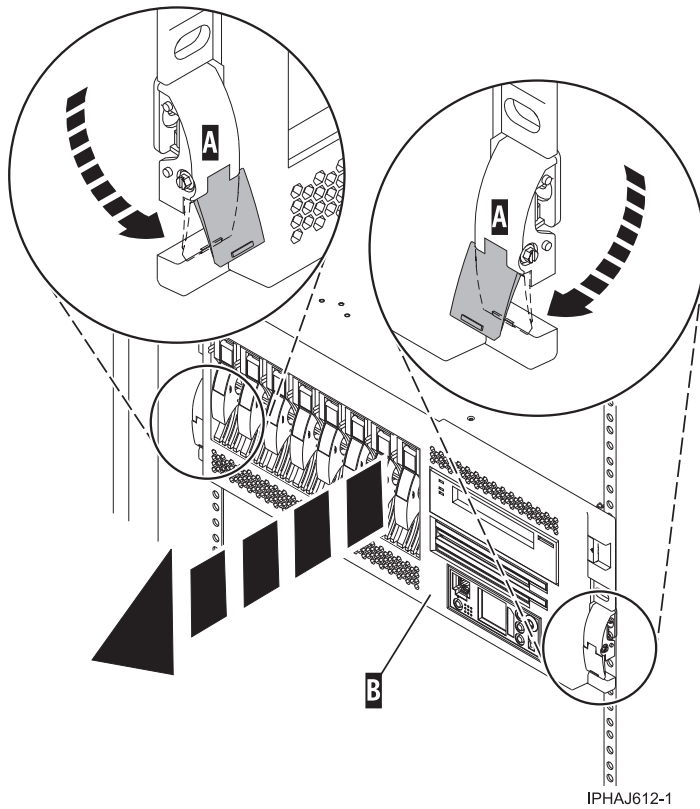

Figure 56. Releasing the rack latches

4. Read the following note, and then slowly pull the system or expansion unit out from the rack until the rails are fully extended and locked.

**Remember:**

- If the procedure you are performing requires you to unplug cables from the back of the system or expansion unit, do so before you pull the unit out from the rack.
- Ensure that the cables at the rear of the system or expansion unit do not catch or bind as you pull the unit out from the rack.
- Ensure the rails are fully extended. When the rails are fully extended, the rail safety latches lock into place. This action prevents the system or expansion unit from being pulled out too far.

## Placing the rack-mounted system or expansion unit in the operating position

Use this procedure to place the rack-mounted system or expansion unit in the operating position to make the unit available for use.

**Tip:** Some of the figures in these procedures might not look exactly like the system or expansion unit that you have. However, the steps to perform the task are the same.

To place the rack-mounted system or expansion unit into the operating position, follow these steps:

1. Simultaneously release the blue rail safety latches (**A**), located near the front of each rail, and push the system or expansion unit into the rack as shown in the following figure.

**Note:** Ensure that the cables at the rear of the system or expansion unit do not catch or bind as you push the unit back into the rack.

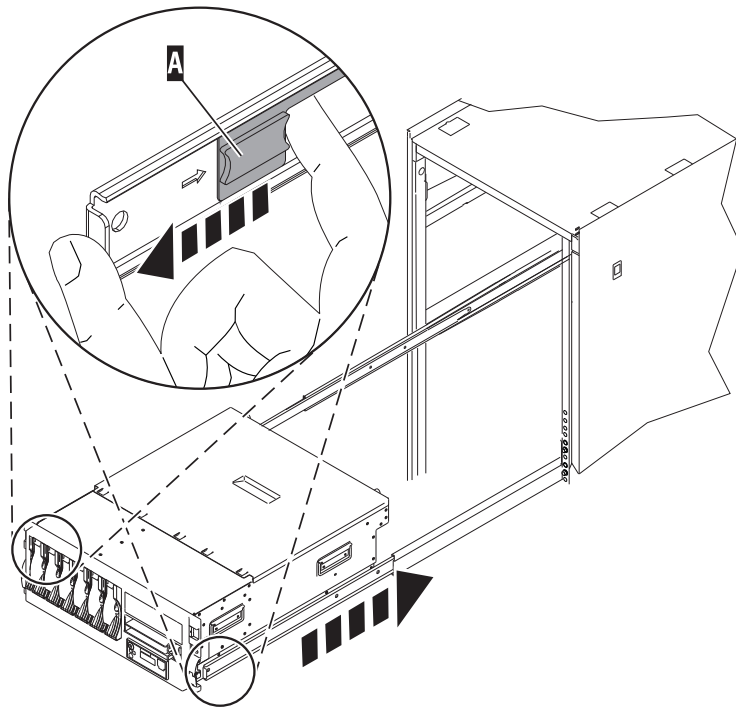

IPHBF509-1

Figure 57. Releasing the rail safety latches

2. Replace and tighten the two thumbscrews (C) that secure the system or expansion unit (A) to the rack as shown in the following figure.

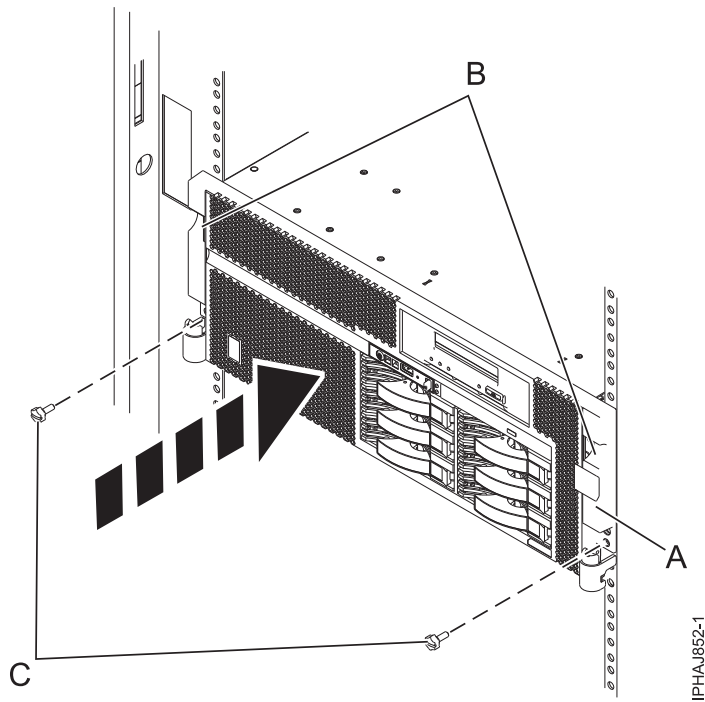

Figure 58. Pushing the system into the rack and attaching the thumbscrews

3. Close the front rack door.

### **Placing a rack-mounted 8203-E4A, 8204-E8A, 8261-E4S, 9407-M15, 9408-M25, or 9409-M50 in the service position**

Use this procedure to perform service or gain access to internal components by placing the rack-mounted system or expansion unit in the service position.

**Note:** Some of the figures in these procedures might not look exactly like the system or expansion unit that you have. However, the steps to perform the task are the same.

## DANGER

When working on or around the system, observe the following precautions:

Electrical voltage and current from power, telephone, and communication cables are hazardous. To avoid a shock hazard:

- Connect power to this unit only with the IBM provided power cord. Do not use the IBM provided power cord for any other product.
- Do not open or service any power supply assembly.
- Do not connect or disconnect any cables or perform installation, maintenance, or reconfiguration of this product during an electrical storm.
- The product might be equipped with multiple power cords. To remove all hazardous voltages, disconnect all power cords.
- Connect all power cords to a properly wired and grounded electrical outlet. Ensure that the outlet supplies proper voltage and phase rotation according to the system rating plate.
- Connect any equipment that will be attached to this product to properly wired outlets.
- When possible, use one hand only to connect or disconnect signal cables.
- Never turn on any equipment when there is evidence of fire, water, or structural damage.
- Disconnect the attached power cords, telecommunications systems, networks, and modems before you open the device covers, unless instructed otherwise in the installation and configuration procedures.
- Connect and disconnect cables as described in the following procedures when installing, moving, or opening covers on this product or attached devices.

To Disconnect:

1. Turn off everything (unless instructed otherwise).
2. Remove the power cords from the outlets.
3. Remove the signal cables from the connectors.
4. Remove all cables from the devices

To Connect:

1. Turn off everything (unless instructed otherwise).
2. Attach all cables to the devices.
3. Attach the signal cables to the connectors.
4. Attach the power cords to the outlets.
5. Turn on the devices.

(D005)

## DANGER

Observe the following precautions when working on or around your IT rack system:

- Heavy equipment—personal injury or equipment damage might result if mishandled.
- Always lower the leveling pads on the rack cabinet.
- Always install stabilizer brackets on the rack cabinet.
- To avoid hazardous conditions due to uneven mechanical loading, always install the heaviest devices in the bottom of the rack cabinet. Always install servers and optional devices starting from the bottom of the rack cabinet.
- Rack-mounted devices are not to be used as shelves or work spaces. Do not place objects on top of rack-mounted devices.



- Each rack cabinet might have more than one power cord. Be sure to disconnect all power cords in the rack cabinet when directed to disconnect power during servicing.
- Connect all devices installed in a rack cabinet to power devices installed in the same rack cabinet. Do not plug a power cord from a device installed in one rack cabinet into a power device installed in a different rack cabinet.
- An electrical outlet that is not correctly wired could place hazardous voltage on the metal parts of the system or the devices that attach to the system. It is the responsibility of the customer to ensure that the outlet is correctly wired and grounded to prevent an electrical shock.

#### CAUTION

- Do not install a unit in a rack where the internal rack ambient temperatures will exceed the manufacturer's recommended ambient temperature for all your rack-mounted devices.
- Do not install a unit in a rack where the air flow is compromised. Ensure that air flow is not blocked or reduced on any side, front, or back of a unit used for air flow through the unit.
- Consideration should be given to the connection of the equipment to the supply circuit so that overloading of the circuits does not compromise the supply wiring or overcurrent protection. To provide the correct power connection to a rack, refer to the rating labels located on the equipment in the rack to determine the total power requirement of the supply circuit.
- *(For sliding drawers.)* Do not pull out or install any drawer or feature if the rack stabilizer brackets are not attached to the rack. Do not pull out more than one drawer at a time. The rack might become unstable if you pull out more than one drawer at a time.
- *(For fixed drawers.)* This drawer is a fixed drawer and must not be moved for servicing unless specified by the manufacturer. Attempting to move the drawer partially or completely out of the rack might cause the rack to become unstable or cause the drawer to fall out of the rack.

(R001)

To place the rack-mounted system or expansion unit into the service position, follow these steps:

1. If necessary, open the front rack door.
2. Remove the two thumbscrews (A) that secure the system unit to the rack as shown in the following figure.
3. Release the rack latches (B) on both the left and right sides as shown in the following figure.

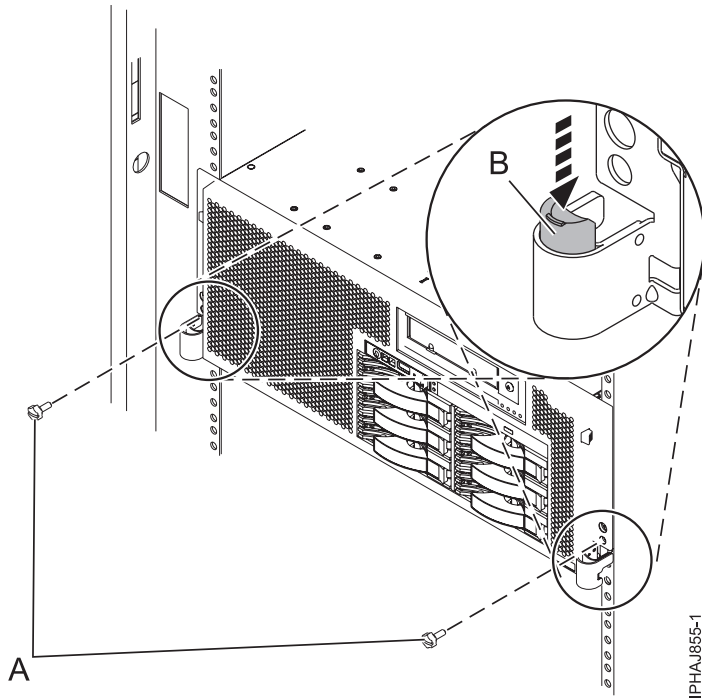

Figure 59. Releasing the rack latches

4. Read the following note, and then slowly pull the system or expansion unit out from the rack until the rails are fully extended and locked.

**Remember:**

- If the procedure you are performing requires you to unplug cables from the back of the system or expansion unit, do so before you pull the unit out from the rack.
- Ensure that the cables at the rear of the system or expansion unit do not catch or bind as you pull the unit out from the rack.
- Ensure the rails are fully extended. When the rails are fully extended, the rail safety latches lock into place. This action prevents the system or expansion unit from being pulled out too far.

### Placing the rack-mounted 8203-E4A, 8204-E8A, 8261-E4S, 9407-M15, 9408-M25, or 9409-M50 in the operating position

Use this procedure to place the rack-mounted system or expansion unit in the operating position to make the unit available for use.

To place the rack-mounted model into the operating position follow these steps:

**Tip:** Some of the figures in these procedures might not look exactly like the system or expansion unit that you have. However, the steps to perform the task are the same.

1. Simultaneously release the blue rail safety latches (B), located near the front of each rail, and push the system or expansion unit into the rack as shown in the following figure.

**Note:** Ensure that the cables at the rear of the system or expansion unit do not catch or bind as you push the unit back into the rack.

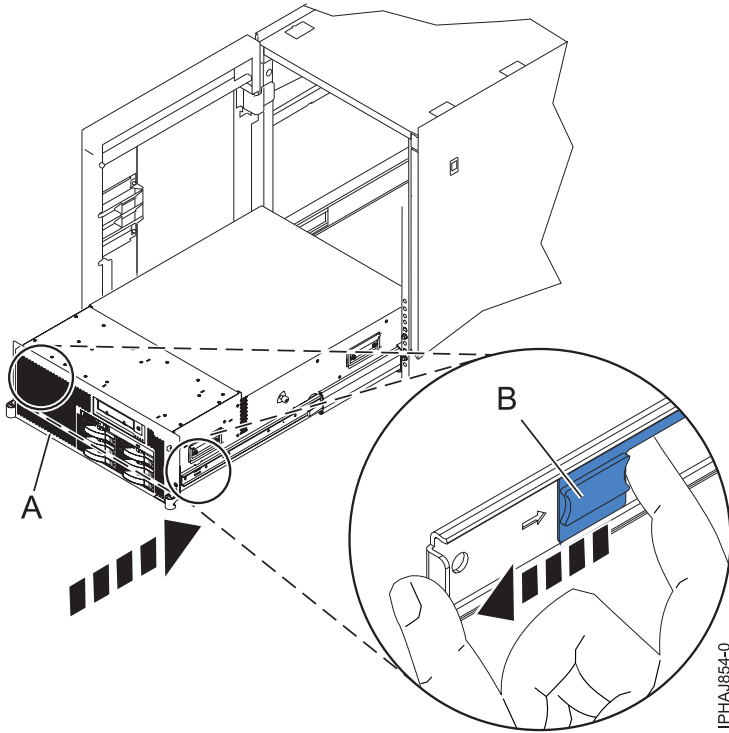

IPHAJ854-0

Figure 60. Releasing the rail safety latches

2. Replace and tighten the two thumbscrews (C) that secure the system or expansion unit (A) to the rack as shown in the following figure.

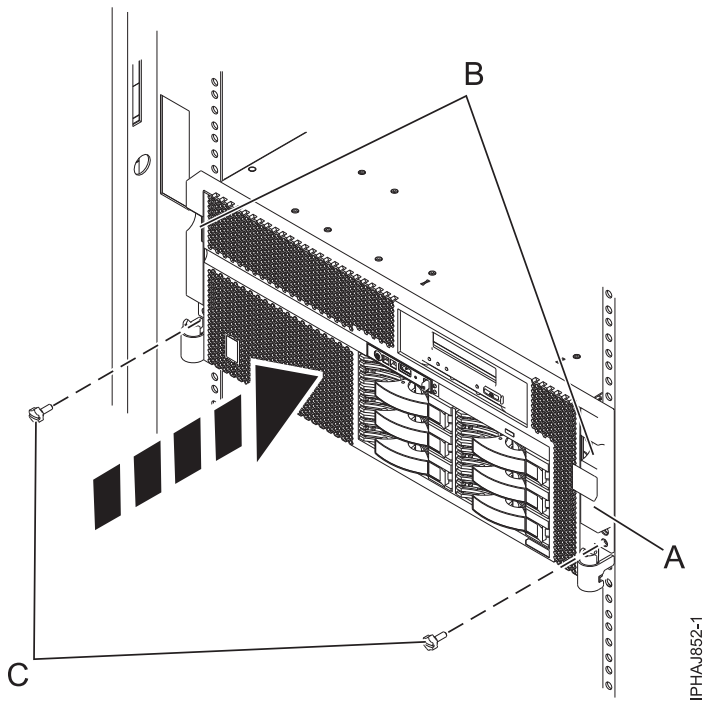

IPHAJ852-1

Figure 61. Replacing the thumbscrews

3. Close the front rack door.

---

## Exchanging a part using the Hardware Management Console

You can use the Hardware Management Console (HMC) to perform many service actions, including exchanging a field replaceable unit (FRU) or part.

If you are exchanging a part to repair a serviceable event follow those instructions. If you are exchanging a part as a part of any other procedure using HMC Version 7 or later use these steps:

1. In the navigation area, expand **Systems Management** → **Servers**.
2. Select the managed system in which you are exchanging a part.
3. In the Tasks area expand **Serviceability** → **Hardware**.
4. Select **Exchange FRU**.
5. In the Replace Hardware - Replace FRU, Select FRU Type window select the system or enclosure in which you will exchange a part from the list.
6. Select the type of part you will exchange from the menu and click **Next**.
7. Select the location code of the part you will exchange from the menu and click **Add**.
8. After the FRU is placed in the **pending actions** category click **Launch Procedure** and follow the instructions to exchange the feature.

**Note:** The HMC might open external instructions for replacing the part. If so, follow those instructions to replace the part.

---

## Hardware service manager Verify option

Use the hardware service manager to verify communications or devices.

To verify communications or devices on any System i<sup>®</sup> model using the hardware service manager *Verify* option, perform the following procedure:

**Note:** Before running a verification test, ensure that the customer is not using the resource you want to test and that all communication jobs on the resource to be tested are ended.

1. From the Start a Service Tool display, select the *Hardware Service Manager* option.
2. From the Hardware Service Manager display, select the *Logical hardware resources* option.
3. From the Logical Hardware Resources display, select the *System bus resources* option.  
This display lists all the I/O processors.
4. Select the *Resources associated with IOP* option for the attached IOP in the list.
5. Select the *Verify* option for the communications, tape, optical storage unit, or File Server adapter that you want to test.
6. When the test completes, the system responds with either a Test is successful message or a Test failed message.

**This ends the procedure.**

### Notes:

1. Hardware units might perform automatic self-tests when they are powered on.
2. You can test some workstations by using the *Test Request* function key while the operating system Sign On display is shown.
3. See the specific device information for possible off-line tests that you can run.

## Verifying an installed feature or replaced part on an AIX system or logical partition

If you installed feature or replaced a part, you might want to use the tools in AIX to verify that the feature or part is recognized by the system or logical partition.

To verify the operation of a newly installed feature or replacement part, select the appropriate procedure:

- Verify the installed feature using AIX
- Verifying the replaced part using AIX

Verify the installed feature using AIX:

1. Log in as root user.
2. At the command line, type `diag` and press Enter.
3. Select **Advanced Diagnostics Routines** and press Enter.
4. From the **Diagnostic Mode Selection** menu, select **System Verification** and press Enter.
5. When the **Advanced Diagnostic Selection** menu appears, do one of the following:
  - To test a single resource, select the resource that you just installed from the list of resources and press Enter.
  - To test all the resources available to the operating system, select **All Resources** and press Enter.
6. Select **Commit**, and wait until the diagnostic programs run to completion, responding to any prompts that appear.
7. Did the diagnostics run to completion and display the message No trouble was found?
  - **No:** If a service request number (SRN) or other reference code is displayed, suspect a loose adapter or cable connection. Review the installation procedures to ensure that the new feature is installed correctly. If you cannot correct the problem, collect all SRNs or any other reference code information that you see. If the system is running in logical partitioning (LPAR) mode, note the logical partition in which you installed the feature. Contact your service provider for assistance.
  - **Yes:** The new device is installed correctly. Exit the diagnostic programs and return the system to normal operations.

Verify the replacement part using AIX:

To verify the operation of a newly installed feature or replacement part, follow these steps:

1. Did you use either the AIX operating system or the online diagnostics service aid concurrent (hot-swap) service to replace the part?
  - No:** Go to step 2.
  - Yes:** Go to step 5 on page 79.
2. Is the system powered off?
  - No:** Go to step 4 on page 79.
  - Yes:** If the system supports slow boot, set the system to perform a slow boot. For information, see *Performing a slow boot*.
3. Start the system and wait until the AIX operating system login prompt is displayed or until apparent system activity on the operator panel or display has stopped.

Did the AIX login prompt display?

  - **No:** If a service request number (SRN) or other reference code is displayed, suspect a loose adapter or cable connection. Review the procedures for the part that you replaced to ensure that the new part is installed correctly. If you cannot correct the problem, collect all SRNs or any other reference code information that you see. If the system does not start or you have no login prompt, see: *Problems with loading and starting the operating system*.

If the system is partitioned, note the logical partition in which you replaced the part. Contact your service provider for assistance.

- **Yes:** Go to step 4.
4. At the command prompt, type `diag -a` and press Enter to check for missing resources. If you see a command prompt, go to step 5.

If the **Diagnostic selection** menu is shown with **M** appearing next to any resource, follow these steps:

- a. Select the resource and press Enter.
  - b. Select **Commit**.
  - c. Follow any instructions that are shown.
  - d. If the *Do you want to review the previously displayed error?* message is shown, select **Yes** and press Enter.
  - e. If an SRN is shown, suspect a loose card or connection. If no obvious problem is shown, record the SRN and contact your service provider for assistance.
  - f. If no SRN is shown, go to step 5.
5. Test the part by doing the following steps:
    - a. At the command line, type `diag` and press Enter.
    - b. From the **Function Selection** menu, select **Advanced Diagnostics Routines** and press Enter.
    - c. From the **Diagnostic Mode Selection** menu, select **System Verification** and press Enter.
    - d. Select **All Resources**, or select the diagnostics for the individual part to test only the part you replaced and any devices that are attached to the part you replaced and press Enter.  
Did the **Resource Repair Action** menu appear?  
**No:** Go to step 6.  
**Yes:** Go to step 7.
  6. Did the *Testing Complete, No trouble was found* message appear?
    - **No:** There is still a problem. Contact your service provider. **This ends the procedure.**
    - **Yes:** Select **Log Repair Action**, if not previously logged, from the **Task Selection** menu to update the AIX error log. If the repair action was reseating a cable or adapter, select the resource associated with that repair action. If the resource associated with your action is not displayed on the resource list, select `sysplanar0` and press Enter.

**Tip:** This action changes the indicator light for the part from the fault state to the normal state. Go to step 9 on page 80.

7. Select the resource for the replaced part from the **Resource Repair Action** menu. When a test is run on a resource in system verification mode, and that resource has an entry in the AIX error log, if the test on the resource was successful, the **Resource Repair Action** menu appears. Complete the following steps to update the AIX error log to indicate that a system-detectable part has been replaced.

**Note:** On systems with an indicator light for the failing part, this action changes the indicator light to the normal state.

- a. Select the resource that has been replaced from the **Resource Repair Action** menu. If the repair action was reseating a cable or adapter, select the resource associated with that repair action. If the resource associated with your action does not appear on the resource list, select `sysplanar0` and press Enter.
- b. Select **Commit** after you make your selections. Did another **Resource Repair Action** display appear?

**No:** If the **No Trouble Found** display appears, go to step 9 on page 80

**Yes:** Go to step 8 on page 80.

8. Select the parent or child of the resource for the replaced part from the **Resource Repair Action** menu if necessary. When a test is run on a resource in system verification mode, and that resource has an entry in the AIX error log, if the test on the resource was successful, the **Resource Repair Action** menu appears. Complete the following steps to update the AIX error log to indicate that a system-detectable part has been replaced.

**Note:** This action changes the indicator light for the part from the fault state to the normal state.

- a. From the **Resource Repair Action** menu, select the parent or child of the resource that has been replaced. If the repair action was to reseal a cable or adapter, select the resource associated with that repair action. If the resource associated with your action does not appear on the resource list, select **sysplanar0** and press Enter.
  - b. Select **Commit** after you make your selections.
  - c. If the **No Trouble Found** display appears, go to step 9.
9. If you changed the service processor or network settings, as instructed in previous procedures, restore the settings to the values they had prior to servicing the system.
  10. Did you do any hot-plug procedures before doing this procedure?
    - No:** Go to step 11.
    - Yes:** Go to step 12.
  11. Start the operating system, with the system or logical partition in normal mode. Were you able to start the operating system?
    - No:** Contact your service provider. **This ends the procedure.**
    - Yes:** Go to step 12.
  12. Are the indicator lights still on?
    - **No. This ends the procedure.**
    - **Yes.** Turn off the lights. See the following for instructions: Changing service indicators.

## Verifying an installed part on an IBM i system or logical partition

If you have installed a new feature or part, verify the feature or part by using the IBM i system service tools.

To verify the installed part follow these steps:

1. Deactivate the failing item indicator light. For instructions, see “Deactivating the failing-part indicator light” on page 44.
2. Sign on **with at least service level authority**.
3. On the command line of the IBM i session, type **strsst** and press Enter.

**Note:** If you cannot get to the System Service Tools display, use function 21 from the control panel. Alternatively, if the system is managed by Hardware Management Console (HMC), use the Service Focal Point Utilities to get to the Dedicated Service Tools (DST) display.

4. Type your service tools user ID and service tools password on the System Service Tools (SST) Sign On display and press Enter.

**Note:** The service tools password is case-sensitive.

5. Select **Start a service tool** from the System Service Tools (SST) display and press Enter.
6. Select **Hardware service manager** from the Start a Service Tool display and press Enter.
7. Select **Logical hardware resources (buses, IOPs, controllers)** from the Hardware Service Manager display and press Enter. This option allows you to display and work with logical resources. Logical hardware resources are the functional resources of the system used by the operating system.

With the Logical Hardware Resources display, you can show logical hardware resource status or information, and associated packaging hardware resources. Use the online Help information to better understand specific functions, fields, or symbols.

## Deactivating the failing-part indicator light

Use this procedure to turn off any indicator light that you turned on as a part of a service action.

To deactivate the indicator light, follow these steps:

1. Select option 7 (Indicator off) to turn off the indicator light.
2. Select the **Acknowledge all errors** function at the bottom of the Service Action Log display, if all problems have been resolved.
3. Close the log entry by selecting option 8 (Close new entry) on the Service Action Log Report display.

## Verifying the installed part on a Linux system or logical partition

If you have installed a new part, learn how to verify that the system recognizes the part.

To verify the newly installed or replaced part, continue with Verifying an installed part using stand-alone diagnostics.

### Verifying an installed part using stand-alone diagnostics

If you have installed or replaced a part, verify that the system recognizes the new part. You can use stand-alone diagnostics to verify an installed part in a Linux system, expansion unit, or logical partition.

- If this server is directly attached to another server or attached to a network, ensure communications with the other servers has stopped.
- The stand-alone diagnostics require use of all of the logical partition resources. No other activity can be running on the logical partition.
- The stand-alone diagnostics require access to the system console.

You access these diagnostics from a CD-ROM or from the Network Installation Management (NIM) server. This procedure describes how to use the diagnostics from a CD-ROM. For information on running diagnostics from the Network Installation Management (NIM) server, see Running stand-alone diagnostics from a Network Installation Management server.

To use stand-alone diagnostics, follow these steps:

1. Stop all jobs and applications and then stop the operating system on the system or logical partition.
2. Remove all tapes, diskettes, and CD-ROM.
3. Turn off the system unit power. The next step boots the server or logical partition from the stand-alone diagnostics CD-ROM. If the optical drive is not available as the boot device on the server or logical partition on which you are working, follow these steps:
  - a. Access the ASMI. See Accessing the ASMI for information on using the ASMI.
  - b. On the ASMI main menu, click on **Power/Restart Control**.
  - c. Click Power On/Off System.
  - d. Select the **Service mode boot from default boot list** option in the AIX or Linux logical partition mode boot drop-down menu.
  - e. Click **Save settings and power on**. As soon as the optical drive has power, insert the standalone diagnostic CD-ROM.
4. After the **keyboard** POST indicator displays on the system console and before the last POST indicator (**speaker**) displays, press the numeric 5 key on the system console to indicate that a service mode boot should be initiated using the default-service mode boot list.
5. Enter any requested password.
6. At the **Diagnostic Operating Instructions** display, press Enter.

**Tip:** If a service request number (SRN) or other reference code is displayed, suspect a loose adapter or cable connection.

**Note:** If you received an SRN or any other reference code when you attempted to start the system, contact your service provider for assistance..

7. If the terminal type is requested, select the **Initialize Terminal** option on the Function Selection menu to initialize the operating system.
8. From the Function Selection menu, select **Advanced Diagnostics Routines** and press Enter.
9. From the Diagnostic Mode Selection menu, select **System Verification** and press Enter.
10. When the Advanced Diagnostic Selection menu appears, select **All Resources**, or test only the part you replaced, and any devices that are attached to the part you replaced, by selecting the diagnostics for the individual part and press Enter.
11. Did the Testing Complete, No trouble was found message appear?
  - **No:** There is still a problem. Contact your service provider.
  - **Yes:** Go to step 12.
12. If you changed the service processor or network settings, as instructed in previous procedures, restore the settings to the value they had prior to servicing the system.
13. If the indicator lights are still on, follow these steps:
  - a. Select **Identify and Attention Indicators** from the Task Selection menu to turn off the system attention and indicator lights and press Enter.
  - b. Select **Set System Attention Indicator to NORMAL** and press Enter.
  - c. Select **Set All Identify Indicators to NORMAL** and press Enter.
  - d. Choose **Commit**.

**Note:** This changes the system attention and identify indicators from the *Fault* state to the *Normal* state.

- e. Exit to the command line.

## Verifying an installed part using Hardware Management Console

If you have installed or replaced a part, use the Hardware Management Console (HMC) to update your HMC records after you have completed a service action on your server. If you have reference codes, symptoms, or location codes that you used during the service action, locate the records for use during this procedure.

To verify an installed part, complete these steps:

1. At the HMC, examine the service action event log for any open service action events. See Viewing serviceable events for details.
2. Are there any service action events that are open?
  - No:** If the system attention or identify LED is still on, use the HMC to turn off the LED. See Activating and Deactivating LEDs. **This ends the procedure.**
  - Yes:** Continue with the next step.
3. Record the list of open service action events.
4. Examine the details of the open service action event. Is the error code associated with this service action event the same as you gathered earlier.
  - **No:** Select one of the following options:
    - Review the other serviceable events, find one that does match, and continue with the next step.
    - If the log does not match what you had gathered earlier, contact your service provider.
  - **Yes:** Continue with the next step.

5. Select and highlight the service action event from the Error Associated With This Serviceable Event window.
6. Click **Close Event**.
7. Add comments for the serviceable event. Include any unique additional information. Click **OK**.
8. Did you replace, add, or modify a field replaceable unit (FRU) of the open service action event?
  - **No:** Select the **No FRU Replaced for this Serviceable Event** option, and click **OK** to close the service action event.
  - **Yes:** Perform the following steps:
    - a. From the FRU list, select a FRU that you need to update.
    - b. Double-click the FRU and update the FRU information.
    - c. Click **OK** to close the service action event.
9. If you continue to have problems, contact your service provider.

### Activating and deactivating LEDs

Use this procedure to activate or deactivate LEDs using Service Focal Point for the HMC.

Choose from the following:

- “Deactivating a system attention LED or partition LED”
- “Activating or deactivating identify LED”

#### Deactivating a system attention LED or partition LED:

You can deactivate a system attention LED or a logical partition LED. For example, you might determine that a problem is not a high priority and decide to repair the problem at a later time. However, you want to be alerted if another problem occurs, so you must deactivate the system attention LED so that it can be activated again if another problem occurs.

1. In the navigation area, open **Systems Management**.
2. Open **Servers** and select the appropriate system.
3. In the content area, check the box for the appropriate Partition.
4. Select **Tasks**, then **Operations**, and then **Manage Attention LED**.
5. Select the appropriate Partition.
6. Select **Deactivate System Attention LED** from the **Action** menu. A confirmation window is displayed that provides the following information:
  - A verification that the system attention LED was deactivated.
  - An indication that there still might be open problems within the system.
  - An indication that you cannot activate the system attention LED.
7. Select one of the logical partitions in the lower table, and select **Deactivate partition LED** from the **Partition Operations** menu. A confirmation window is displayed that provides the following information:
  - A verification that the logical partition LED was deactivated.
  - An indication that there still might be open problems within the logical partition.
  - An indication that you cannot activate the logical partition LED.

#### Activating or deactivating identify LED:

The system provides several LEDs that help identify various components, such as enclosures or field replaceable units (FRUs), in the system. For this reason, they are called identify LEDs.

You can activate or deactivate the following types of identify LEDs:

- **Identify LED for an enclosure** If you want to add an adapter to a specific drawer (enclosure), you need to know the machine type, model, and serial number (MTMS) of the drawer. To determine whether you have the correct MTMS for the drawer that needs the new adapter, you can activate the LED in a drawer and verify that the MTMS corresponds to the drawer that requires the new adapter.
- **Identify LED for a FRU associated with a specified enclosure** If you want to hook up a cable to a specific I/O adapter, you can activate the LED for the adapter which is a field replaceable unit (FRU), and then physically check to see where you should hook up the cable. This is especially useful when you have several adapters with open ports.

To activate or deactivate an identify LED for an enclosure or FRU, follow these steps:

1. In the navigation area, open **Systems Management**.
2. Select **Servers**.
3. In the content area, check the box for the appropriate system.
4. Select **Tasks**, then **Operations**, then **LED Status**, and then **Identify LED**.
5. To activate or deactivate an identify LED for an enclosure, select an enclosure from the table, and click either **Activate LED** or **Deactivate LED**. The associated LED is either turned on or off.
6. To activate or deactivate an identify LED for a FRU, select an enclosure from the table, select **Selected** → **List FRUs**.
7. Select one or more FRUs from the table, and click either **Activate LED** or **Deactivate LED**. The associated LED is either turned on or off.

## Viewing serviceable events

Use this procedure to view a serviceable event, including details, comments, and service history.

To view serviceable events and other information about the events, you must be a member of one of the following roles:

- Super administrator
- Service representative
- Operator
- Product engineer
- Viewer

To view serviceable events, follow these steps:

1. In the navigation area, select **Service Management**.
2. Select **Manage Serviceable Events**.
3. Select the criteria for the serviceable events that you want to view, and click **OK**. The Serviceable Event Overview window opens. The list shows all serviceable events that match your selection criteria. You can use the menu options to perform actions on the serviceable events.
4. Select a line in the Serviceable Event Overview window, and select **Selected** → **View Details**. The Serviceable Event Details window opens, showing detailed information about the serviceable event. The upper table shows information, such as problem number and reference code. The lower table shows the field replaceable units (FRUs) associated with this event.
5. Select the error for which you want to view comments and history, and follow these steps:
  - a. Select **Actions** → **View Comments**.
  - b. When you are finished viewing the comments, click **Close**.
  - c. Select **Actions** → **View Service History**. The Service History window opens, showing service history associated with the selected error.
  - d. When you are finished viewing the service history, click **Close**.
6. When you are finished, click **Cancel** twice to close the Serviceable Event Details window and the Serviceable Event Overview window.

## Verifying an installed feature or replaced part on a system or logical partition using Virtual I/O Server tools

If you installed feature or replaced a part, you might want to use the tools in Virtual I/O Server (VIOS) to verify that the feature or part is recognized by the system or logical partition.

To verify the operation of a newly installed feature or replacement part, select the appropriate procedure:

- Verify the installed feature using VIOS
- Verifying the replaced part using VIOS

Verify the installed feature using VIOS:

1. Log in as root user.
2. At the command line, type `diagmenu` and press Enter.
3. Select **Advanced Diagnostics Routines** and press Enter.
4. From the **Diagnostic Mode Selection** menu, select **System Verification** and press Enter.
5. When the **Advanced Diagnostic Selection** menu appears, do one of the following:
  - To test a single resource, select the resource that you just installed from the list of resources and press Enter.
  - To test all the resources available to the operating system, select **All Resources** and press Enter.
6. Select **Commit**, and wait until the diagnostic programs run to completion, responding to any prompts that appear.
7. Did the diagnostics run to completion and display the message No trouble was found?
  - **No:** If a service request number (SRN) or other reference code is displayed, suspect a loose adapter or cable connection. Review the installation procedures to ensure that the new feature is installed correctly. If you cannot correct the problem, collect all SRNs or any other reference code information that you see. If the system is running in LPAR mode, note the logical partition in which you installed the feature. Contact your service provider for assistance.
  - **Yes:** The new device is installed correctly. Exit the diagnostic programs and return the system to normal operations.

Verify the replacement part using VIOS:

To verify the operation of a newly installed feature or replacement part, follow these steps:

1. Did you replace the part using either VIOS or the online diagnostics service aid's concurrent (hot-swap) service operation?
  - No:** Go to step 2.
  - Yes:** Go to step 5 on page 86.
2. Is the system powered off?
  - No:** Go to step 4 on page 86.
  - Yes:** If the system supports slow boot, set the system to perform a slow boot. For information, see *Performing a slow boot*.
3. Start the system and wait until the VIOS operating system login prompt displays or until apparent system activity on the operator panel or display has stopped.

Did the VIOS login prompt display?

  - **No:** If an SRN or other reference code is displayed, suspect a loose adapter or cable connection. Review the procedures for the part that you replaced to ensure that the new part is installed correctly. If you cannot correct the problem, collect all SRNs or any other reference code information that you see. If the system does not start or you have no login prompt, see: *Problems with loading and starting the operating system*.

If the system is partitioned, note the logical partition in which you replaced the part. Contact your service provider for assistance.

- **Yes:** Go to step 4
4. At the command prompt, type `diag -a` and press Enter to check for missing resources. If you see a command prompt, go to step 5.

If the **Diagnostic selection** menu is shown with **M** appearing next to any resource, follow these steps:

- a. Select the resource and press Enter.
  - b. Select **Commit**.
  - c. Follow any instructions that are shown.
  - d. If a *Do you want to review the previously displayed error?* message is shown, select **Yes** and press Enter.
  - e. If an SRN is shown, suspect a loose card or connection. If no obvious problem is shown, record the SRN and contact your service provider for assistance..
  - f. If no SRN is shown, go to 5.
5. Test the part by doing the following:
- a. At the command line, type `diagmenu` and press Enter.
  - b. From the **Function Selection** menu, select **Advanced Diagnostics Routines** and press Enter.
  - c. From the **Diagnostic Mode Selection** menu, select **System Verification** and press Enter.
  - d. Select **All Resources**, or select the diagnostics for the individual part to test only the part you replaced, and any devices that are attached to the part you replaced and press Enter.  
Did the **Resource Repair Action** menu appear?  
**No:** Go to step 6.  
**Yes:** Go to step 7.
6. Did the *Testing Complete, No trouble was found* message appear?
- **No:** There is still a problem. Contact your service provider. **This ends the procedure.**
  - **Yes:** Select **Log Repair Action**, if not previously logged, from the **Task Selection** menu to update the AIX error log. If the repair action was reseating a cable or adapter, select the resource associated with that repair action. If the resource associated with your action is not displayed on the Resource List, select `sysplanar0` and press Enter.

**Tip:** This action changes the indicator light for the part from the fault state to the normal state. Go to step 9 on page 87.

7. Select the resource for the replaced part from the **Resource Repair Action** menu. When a test is run on a resource in system verification mode, and that resource has an entry in the AIX error log, if the test on the resource was successful, the **Resource Repair Action** menu appears. Complete the following steps to update the AIX error log to indicate that a system-detectable part has been replaced.

**Note:** On systems with a indicator light for the failing part, this changes the indicator light to the normal state.

- a. Select the resource that has been replaced from the **Resource Repair Action** menu. If the repair action was reseating a cable or adapter, select the resource associated with that repair action. If the resource associated with your action does not appear on the Resource List, select `sysplanar0`. Press Enter.
- b. Select **Commit** after you make your selections. Did another **Resource Repair Action** display appear?  
**No:** If the **No Trouble Found** display appears, go to step 9 on page 87.  
**Yes:** Go to step 8 on page 87.

8. Select the parent or child of the resource for the replaced part from the **Resource Repair Action** menu if necessary. When a test is run on a resource in system verification mode, and that resource has an entry in the AIX error log, if the test on the resource was successful, the **Resource Repair Action** menu appears. Complete the following steps to update the AIX error log to indicate that a system-detectable part has been replaced.  
  
**Note:** This changes the indicator light for the part from the fault state to the normal state.
  - a. From the **Resource Repair Action** menu, select the parent or child of the resource that has been replaced. If the repair action was to reseal a cable or adapter, select the resource associated with that repair action. If the resource associated with your action does not appear on the Resource List, select **sysplanar0**. Press Enter.
  - b. Select **Commit** after you make your selections.
  - c. If the **No Trouble Found** display appears, go to step 9.
9. If you changed the service processor or network settings, as instructed in previous procedures, restore the settings to the values they had prior to servicing the system.
10. Did you do any hot-plug procedures before doing this procedure?  
**No:** Go to step 11.  
**Yes:** Go to step 12.
11. Start the operating system, with the system or logical partition in normal mode. Were you able to start the operating system?  
**No:** Contact your service provider. **This ends the procedure.**  
**Yes:** Go to step 12.
12. Are the indicator lights still on?
  - **No. This ends the procedure.**
  - **Yes.** Turn off the lights. For instructions, see Changing service indicators



---

## Appendix. Notices

This information was developed for products and services offered in the U.S.A.

The manufacturer may not offer the products, services, or features discussed in this document in other countries. Consult the manufacturer's representative for information on the products and services currently available in your area. Any reference to the manufacturer's product, program, or service is not intended to state or imply that only that product, program, or service may be used. Any functionally equivalent product, program, or service that does not infringe any intellectual property right of the manufacturer may be used instead. However, it is the user's responsibility to evaluate and verify the operation of any product, program, or service.

The manufacturer may have patents or pending patent applications covering subject matter described in this document. The furnishing of this document does not grant you any license to these patents. You can send license inquiries, in writing, to the manufacturer.

**The following paragraph does not apply to the United Kingdom or any other country where such provisions are inconsistent with local law:** THIS INFORMATION IS PROVIDED "AS IS" WITHOUT WARRANTY OF ANY KIND, EITHER EXPRESS OR IMPLIED, INCLUDING, BUT NOT LIMITED TO, THE IMPLIED WARRANTIES OF NON-INFRINGEMENT, MERCHANTABILITY OR FITNESS FOR A PARTICULAR PURPOSE. Some states do not allow disclaimer of express or implied warranties in certain transactions, therefore, this statement may not apply to you.

This information could include technical inaccuracies or typographical errors. Changes are periodically made to the information herein; these changes will be incorporated in new editions of the publication. The manufacturer may make improvements and/or changes in the product(s) and/or the program(s) described in this publication at any time without notice.

Any references in this information to Web sites not owned by the manufacturer are provided for convenience only and do not in any manner serve as an endorsement of those Web sites. The materials at those Web sites are not part of the materials for this product and use of those Web sites is at your own risk.

The manufacturer may use or distribute any of the information you supply in any way it believes appropriate without incurring any obligation to you.

Any performance data contained herein was determined in a controlled environment. Therefore, the results obtained in other operating environments may vary significantly. Some measurements may have been made on development-level systems and there is no guarantee that these measurements will be the same on generally available systems. Furthermore, some measurements may have been estimated through extrapolation. Actual results may vary. Users of this document should verify the applicable data for their specific environment.

Information concerning products not produced by this manufacturer was obtained from the suppliers of those products, their published announcements or other publicly available sources. This manufacturer has not tested those products and cannot confirm the accuracy of performance, compatibility or any other claims related to products not produced by this manufacturer. Questions on the capabilities of products not produced by this manufacturer should be addressed to the suppliers of those products.

All statements regarding the manufacturer's future direction or intent are subject to change or withdrawal without notice, and represent goals and objectives only.

The manufacturer's prices shown are the manufacturer's suggested retail prices, are current and are subject to change without notice. Dealer prices may vary.

This information is for planning purposes only. The information herein is subject to change before the products described become available.

This information contains examples of data and reports used in daily business operations. To illustrate them as completely as possible, the examples include the names of individuals, companies, brands, and products. All of these names are fictitious and any similarity to the names and addresses used by an actual business enterprise is entirely coincidental.

If you are viewing this information in softcopy, the photographs and color illustrations may not appear.

The drawings and specifications contained herein shall not be reproduced in whole or in part without the written permission of the manufacturer.

The manufacturer has prepared this information for use with the specific machines indicated. The manufacturer makes no representations that it is suitable for any other purpose.

The manufacturer's computer systems contain mechanisms designed to reduce the possibility of undetected data corruption or loss. This risk, however, cannot be eliminated. Users who experience unplanned outages, system failures, power fluctuations or outages, or component failures must verify the accuracy of operations performed and data saved or transmitted by the system at or near the time of the outage or failure. In addition, users must establish procedures to ensure that there is independent data verification before relying on such data in sensitive or critical operations. Users should periodically check the manufacturer's support websites for updated information and fixes applicable to the system and related software.

---

## Trademarks

IBM, the IBM logo, and [ibm.com](http://ibm.com) are trademarks or registered trademarks of International Business Machines Corp., registered in many jurisdictions worldwide. Other product and service names might be trademarks of IBM or other companies. A current list of IBM trademarks is available on the Web at Copyright and trademark information at [www.ibm.com/legal/copytrade.shtml](http://www.ibm.com/legal/copytrade.shtml).

Linux is a registered trademark of Linus Torvalds in the United States, other countries, or both.

Other company, product, or service names may be trademarks or service marks of others.

---

## Electronic emission notices

### Class A Notices

The following Class A statements apply to the IBM servers that contain the POWER6 processor.

### Federal Communications Commission (FCC) statement

**Note:** This equipment has been tested and found to comply with the limits for a Class A digital device, pursuant to Part 15 of the FCC Rules. These limits are designed to provide reasonable protection against harmful interference when the equipment is operated in a commercial environment. This equipment generates, uses, and can radiate radio frequency energy and, if not installed and used in accordance with the instruction manual, may cause harmful interference to radio communications. Operation of this equipment in a residential area is likely to cause harmful interference, in which case the user will be required to correct the interference at his own expense.

Properly shielded and grounded cables and connectors must be used in order to meet FCC emission limits. IBM is not responsible for any radio or television interference caused by using other than recommended cables and connectors or by unauthorized changes or modifications to this equipment. Unauthorized changes or modifications could void the user's authority to operate the equipment.

This device complies with Part 15 of the FCC rules. Operation is subject to the following two conditions: (1) this device may not cause harmful interference, and (2) this device must accept any interference received, including interference that may cause undesired operation.

### **Industry Canada Compliance Statement**

This Class A digital apparatus complies with Canadian ICES-003.

### **Avis de conformité à la réglementation d'Industrie Canada**

Cet appareil numérique de la classe A respecte est conforme à la norme NMB-003 du Canada.

### **European Community Compliance Statement**

This product is in conformity with the protection requirements of EU Council Directive 2004/108/EC on the approximation of the laws of the Member States relating to electromagnetic compatibility. IBM cannot accept responsibility for any failure to satisfy the protection requirements resulting from a non-recommended modification of the product, including the fitting of non-IBM option cards.

This product has been tested and found to comply with the limits for Class A Information Technology Equipment according to European Standard EN 55022. The limits for Class A equipment were derived for commercial and industrial environments to provide reasonable protection against interference with licensed communication equipment.

European Community contact:  
IBM Technical Regulations  
Pascalstr. 100, Stuttgart, Germany 70569  
Tele: 0049 (0)711 785 1176  
Fax: 0049 (0)711 785 1283  
E-mail: tjahn@de.ibm.com

**Warning:** This is a Class A product. In a domestic environment, this product may cause radio interference, in which case the user may be required to take adequate measures.

### **VCCI Statement - Japan**

この装置は、クラスA情報技術装置です。この装置を家庭環境で使用すると電波妨害を引き起こすことがあります。この場合には使用者が適切な対策を講ずるよう要求されることがあります。

VCCI-A

The following is a summary of the VCCI Japanese statement in the box above:

This is a Class A product based on the standard of the VCCI Council. If this equipment is used in a domestic environment, radio interference may occur, in which case, the user may be required to take corrective actions.

**Japanese Electronics and Information Technology Industries Association (JEITA)  
Confirmed Harmonics Guideline (products less than or equal to 20 A per phase)**

高調波ガイドライン適合品

**Japanese Electronics and Information Technology Industries Association (JEITA)  
Confirmed Harmonics Guideline with Modifications (products greater than 20 A per phase)**

高調波ガイドライン準用品

**Electromagnetic Interference (EMI) Statement - People's Republic of China**

**声 明**

此为 A 级产品,在生活环境中,  
该产品可能会造成无线电干扰。  
在这种情况下,可能需要用户对其  
干扰采取切实可行的措施。

Declaration: This is a Class A product. In a domestic environment this product may cause radio interference in which case the user may need to perform practical action.

**Electromagnetic Interference (EMI) Statement - Taiwan**

**警告使用者：**

這是甲類的資訊產品，在  
居住的環境中使用時，可  
能會造成射頻干擾，在這  
種情況下，使用者會被要  
求採取某些適當的對策。

The following is a summary of the EMI Taiwan statement above.

Warning: This is a Class A product. In a domestic environment this product may cause radio interference in which case the user will be required to take adequate measures.

**IBM Taiwan Contact Information:**

台灣IBM 產品服務聯絡方式：  
台灣國際商業機器股份有限公司  
台北市松仁路7號3樓  
電話：0800-016-888

## Electromagnetic Interference (EMI) Statement - Korea

이 기기는 업무용으로 전자파적합등록을 한 기기이오니 판매자 또는 사용자는 이점을 주의하시기 바라며, 만약 잘못 판매 또는 구입하였을 때에는 가정용으로 교환하시기 바랍니다.

Please note that this equipment has obtained EMC registration for commercial use. In the event that it has been mistakenly sold or purchased, please exchange it for equipment certified for home use.

## Germany Compliance Statement

### Deutschsprachiger EU Hinweis: Hinweis für Geräte der Klasse A EU-Richtlinie zur Elektromagnetischen Verträglichkeit

Dieses Produkt entspricht den Schutzanforderungen der EU-Richtlinie 2004/108/EG zur Angleichung der Rechtsvorschriften über die elektromagnetische Verträglichkeit in den EU-Mitgliedsstaaten und hält die Grenzwerte der EN 55022 Klasse A ein.

Um dieses sicherzustellen, sind die Geräte wie in den Handbüchern beschrieben zu installieren und zu betreiben. Des Weiteren dürfen auch nur von der IBM empfohlene Kabel angeschlossen werden. IBM übernimmt keine Verantwortung für die Einhaltung der Schutzanforderungen, wenn das Produkt ohne Zustimmung der IBM verändert bzw. wenn Erweiterungskomponenten von Fremdherstellern ohne Empfehlung der IBM gesteckt/eingebaut werden.

EN 55022 Klasse A Geräte müssen mit folgendem Warnhinweis versehen werden:

"Warnung: Dieses ist eine Einrichtung der Klasse A. Diese Einrichtung kann im Wohnbereich Funk-Störungen verursachen; in diesem Fall kann vom Betreiber verlangt werden, angemessene Maßnahmen zu ergreifen und dafür aufzukommen."

### Deutschland: Einhaltung des Gesetzes über die elektromagnetische Verträglichkeit von Geräten

Dieses Produkt entspricht dem "Gesetz über die elektromagnetische Verträglichkeit von Geräten (EMVG)". Dies ist die Umsetzung der EU-Richtlinie 2004/108/EG in der Bundesrepublik Deutschland.

### Zulassungsbescheinigung laut dem Deutschen Gesetz über die elektromagnetische Verträglichkeit von Geräten (EMVG) (bzw. der EMC EG Richtlinie 2004/108/EG) für Geräte der Klasse A.

Dieses Gerät ist berechtigt, in Übereinstimmung mit dem Deutschen EMVG das EG-Konformitätszeichen - CE - zu führen.

Verantwortlich für die Konformitätserklärung nach des EMVG ist die IBM Deutschland GmbH, 70548 Stuttgart.

Generelle Informationen:

Das Gerät erfüllt die Schutzanforderungen nach EN 55024 und EN 55022 Klasse A.

## Electromagnetic Interference (EMI) Statement - Russia

**ВНИМАНИЕ!** Настоящее изделие относится к классу А.  
В жилых помещениях оно может создавать радиопомехи, для снижения которых необходимы дополнительные меры

---

## Terms and conditions

Permissions for the use of these publications is granted subject to the following terms and conditions.

**Personal Use:** You may reproduce these publications for your personal, noncommercial use provided that all proprietary notices are preserved. You may not distribute, display or make derivative works of these publications, or any portion thereof, without the express consent of the manufacturer.

**Commercial Use:** You may reproduce, distribute and display these publications solely within your enterprise provided that all proprietary notices are preserved. You may not make derivative works of these publications, or reproduce, distribute or display these publications or any portion thereof outside your enterprise, without the express consent of the manufacturer.

Except as expressly granted in this permission, no other permissions, licenses or rights are granted, either express or implied, to the publications or any data, software or other intellectual property contained therein.

The manufacturer reserves the right to withdraw the permissions granted herein whenever, in its discretion, the use of the publications is detrimental to its interest or, as determined by the manufacturer, the above instructions are not being properly followed.

You may not download, export or re-export this information except in full compliance with all applicable laws and regulations, including all United States export laws and regulations.

THE MANUFACTURER MAKES NO GUARANTEE ABOUT THE CONTENT OF THESE PUBLICATIONS. THESE PUBLICATIONS ARE PROVIDED "AS-IS" AND WITHOUT WARRANTY OF ANY KIND, EITHER EXPRESSED OR IMPLIED, INCLUDING BUT NOT LIMITED TO IMPLIED WARRANTIES OF MERCHANTABILITY, NON-INFRINGEMENT, AND FITNESS FOR A PARTICULAR PURPOSE.





Printed in USA