

z/OS



# DFSMS Software Support for IBM System Storage TS1140, TS1130, and TS1120 Tape Drives (3592)

*Version 2 Release 1*

**Note**

Before using this information and the product it supports, read the information in "Notices" on page 421.

This edition applies to Version 2 Release 1 of z/OS (5650-ZOS) and to all subsequent releases and modifications until otherwise indicated in new editions.

This edition replaces SC26-7514-05.

© **Copyright IBM Corporation 1973, 2013.**

US Government Users Restricted Rights – Use, duplication or disclosure restricted by GSA ADP Schedule Contract with IBM Corp.

# Contents

**Figures . . . . . xi**

**Tables . . . . . xiii**

**About this document . . . . . xv**

Required product knowledge . . . . . xv

Referenced information centers . . . . . xv

z/OS information . . . . . xvi

Notational conventions . . . . . xvi

    How to read syntax diagrams . . . . . xvi

    How to read syntax conventions . . . . . xvii

**How to send your comments to IBM . . . . . xxi**

If you have a technical problem . . . . . xxi

**Summary of changes . . . . . xxiii**

z/OS Version 2 Release 1 summary of changes . . . . . xxiii

## **Part 1. TS1140 tape drive . . . . . 1**

### **Chapter 1. Introduction for TS1140 tape drive . . . . . 3**

TS1140 tape drive . . . . . 3

Tape encryption . . . . . 3

Key management for TS1140 . . . . . 5

    Key store for TS1140 . . . . . 5

    IBM Security Key Lifecycle Manager . . . . . 5

    Tivoli Key Lifecycle Manager (TKLM) . . . . . 6

    Encryption Key Manager (EKM) . . . . . 6

    In-band proxy for TS1140 . . . . . 6

    Management interfaces for TS1140 . . . . . 6

Key label specifications for TS1140 . . . . . 6

Volume label support for TS1140 . . . . . 7

Volume recovery for TS1140 . . . . . 7

Re-keying support for TS1140 . . . . . 7

Recording format and media support for TS1140 tape drives . . . . . 7

Performance scaling and segmentation for TS1140 . . . . . 9

z/OS software support for the TS1140 tape drive . . . . . 10

    Using TS1140 tape drives in an IBM tape library environment . . . . . 11

    Using TS1140 tape drives in a stand-alone environment . . . . . 12

Resolving recording technology conflicts for TS1140 . . . . . 12

Implementation considerations for using TS1140 tape drives . . . . . 13

### **Chapter 2. Migration to the software support for TS1140 tape drives . . . . . 15**

Understanding coexistence considerations for TS1140 . . . . . 15

Preparing to install the software . . . . . 18

Installing the appropriate PTFs . . . . . 18

Planning for DFSMS software support for the TS1140 tape drive . . . . . 18

Implementing the DFSMS software support for the TS1140 tape drive . . . . . 26

### **Chapter 3. Access method services (AMS) modifications for TS1140 tape drives . . . . . 31**

ALTER LIBRARYENTRY . . . . . 31

    Changed parameters for ALTER LIBRARYENTRY . . . . . 31

ALTER VOLUMEENTRY . . . . . 32

    EFMT4 and EEFMT4 subparameter for ALTER VOLUMEENTRY . . . . . 32

CREATE LIBRARYENTRY . . . . . 32

    Changed parameters for CREATE LIBRARYENTRY . . . . . 32

CREATE VOLUMEENTRY . . . . . 33

    EFMT4 and EEFMT4 subparameters for CREATE VOLUMEENTRY . . . . . 33

DCOLLECT . . . . . 34

    DDCEFMT4 and DDCEEFM4 subparameter for DCOLLECT . . . . . 34

LISTCAT . . . . . 34

    EFMT4 and EEFMT4 subparameters in List tape volume entries sample output . . . . . 35

    volume entries sample output . . . . . 35

### **Chapter 4. Tape drive and tape volume allocation modifications for TS1140 tape drives . . . . . 37**

Device support modifications . . . . . 37

    IOS000I Message with Encryption Failure . . . . . 39

SMS modifications . . . . . 41

    In Data Class . . . . . 41

    Overriding Attributes Defined in the Data Class . . . . . 41

MVS device allocation modifications . . . . . 41

JCL DD Statement Parameters and Equivalent Text Units for TS1140 . . . . . 43

DSNAME Allocation Text Units for TS1140 . . . . . 43

Verb Code 01 - Non-JCL Dynamic Allocation Functions for TS1140 . . . . . 43

    Volume Interchange Specification - Key = '006F' . . . . . 43

### **Chapter 5. ISMF modifications for TS1140 tape drive . . . . . 45**

Data class define and alter panels . . . . . 45

Mountable tape volume list panel . . . . . 45

Tape library define and alter panels . . . . . 45

### **Chapter 6. OCE modifications for TS1140 tape drive . . . . . 47**

Overview . . . . . 47

SMS Managed Tape . . . . . 47

WORM support . . . . . 47

Recording Technology Conflict . . . . . 47

Multiple Recording Format Capability . . . . .	48
Cartridge Reuse with DISP=OLD SHR . . . . .	48
OCE Tape Installation Exits . . . . .	48
Multiple Recording Format Capability . . . . .	49
IEZDEB (second DEB extension) . . . . .	49

**Chapter 7. DFSMSdss considerations for the TS1140 tape drive . . . . . 51**

**Chapter 8. DFSMSHsm considerations for the TS1140 tape drive . . . . . 53**

Modifying your SMS data classes . . . . .	53
Modifying your dump classes . . . . .	53
Input tape utilization . . . . .	54
Requesting information for encrypted volumes and tapes . . . . .	54
Displaying EFMT4 and EEFMT4 formatted volumes . . . . .	55
Displaying encrypted tape volumes . . . . .	55
Requesting information for dump volumes . . . . .	55
Specifying esoteric tape unit names to DFSMSHsm . . . . .	56
Tape Hardware Emulation . . . . .	56
Specifying how much of a tape DFSMSHsm uses . . . . .	57
Using tape device naming conventions . . . . .	57
Output tape selection . . . . .	58
Output tape utilization . . . . .	58
Scratch Tapes . . . . .	58
Partial Tapes . . . . .	58
Input tape utilization . . . . .	59
Reuse Capacity . . . . .	59
Mixed Device Esoteric Units . . . . .	59
Allowing DFSMSHsm to use the 3590-1 generic unit when it contains mixed track technology drives . . . . .	59
Recovering overwritten encrypted tapes . . . . .	60
DFSMSHsm tips . . . . .	60

**Chapter 9. DFSMSrmm modifications for TS1140 tape drive . . . . . 61**

DFSMSrmm TSO subcommands . . . . .	61
ADDVOLUME . . . . .	61
CHANGEVOLUME . . . . .	62
SEARCHVOLUME . . . . .	63
ADDDATASET . . . . .	64
CHANGEDATASET . . . . .	65
LISTDATASET . . . . .	65
LISTVOLUME . . . . .	66
DFSMSrmm REXX variables . . . . .	67
DFSMSrmm structured field introducers . . . . .	67
Compound SFI . . . . .	69
DFSMSrmm macros . . . . .	69

**Chapter 10. EREP modifications for TS1140 tape drive . . . . . 73**

TAPE subsystem exception report . . . . .	73
Emulated device summary report . . . . .	73
TAPE Media Informational Messages (MIMs) . . . . .	74

**Chapter 11. JES3 modifications for TS1140 tape drive . . . . . 75**

**Chapter 12. OAM modifications for TS1140 tape drive . . . . . 77**

OAM library support . . . . .	77
LCS external services changes . . . . .	78
OAM installation exits changes . . . . .	78
Operator command support changes . . . . .	78
Mount processing change . . . . .	79
OAM macro changes . . . . .	79
Cartridge entry processing . . . . .	81
OAM object tape support . . . . .	81
Object tape migration considerations . . . . .	82
Object tape volume management support . . . . .	83

**Chapter 13. MVS IOS support for TS1140 tape drive . . . . . 85**

**Part 2. TS1130 tape drive . . . . . 87**

**Chapter 14. Introduction for TS1130 tape drive . . . . . 89**

TS1130 tape drive . . . . .	89
Tape encryption . . . . .	89
Key management for TS1130 . . . . .	91
Key store for TS1130 . . . . .	91
Encryption Key Manager (EKM) for TS1130 . . . . .	91
Tivoli Key Lifecycle Manager (TKLM) . . . . .	91
In-band proxy for TS1130 . . . . .	92
Management interfaces for TS1130 . . . . .	92
Key label specifications for TS1130 . . . . .	92
Volume label support for TS1130 . . . . .	92
Volume recovery for TS1130 . . . . .	92
Re-keying support for TS1130 . . . . .	92
Recording format and media support for TS1130 tape drives . . . . .	92
Performance scaling and segmentation for TS1130 . . . . .	95
z/OS software support for the TS1130 tape drive . . . . .	95
Using TS1130 tape drives in an IBM tape library environment . . . . .	97
Using TS1130 tape drives in a stand-alone environment . . . . .	97
Resolving recording technology conflicts for TS1130 . . . . .	97
Implementation considerations for using TS1130 tape drives . . . . .	98

**Chapter 15. Migration to the software support for TS1130 tape drives . . . . . 99**

Understanding coexistence considerations for TS1130 . . . . .	99
Preparing to install the software . . . . .	102
Installing the appropriate PTFs . . . . .	102
Planning for DFSMS software support for the TS1130 tape drive . . . . .	102
Implementing the DFSMS software support for the TS1130 tape drive . . . . .	109

**Chapter 16. Access method services (AMS) modifications . . . . . 113**

Enterprise format 3 (EFMT3) and enterprise encrypted format 3 (EEFMT3) . . . . . 113  
EFMT3 and EEFMT3 support for ALTER VOLUMEENTRY . . . . . 113  
    EFMT3 and EEFMT3 subparameter for ALTER VOLUMEENTRY . . . . . 114  
EFMT3 and EEFMT3 support for CREATE VOLUMEENTRY . . . . . 114  
    EFMT3 and EEFMT3 subparameters for CREATE VOLUMEENTRY . . . . . 114  
EFMT3 and EEFMT3 Support for DCOLLECT . . . . . 114  
    EFMT3 and EEFMT3 subparameter for DCOLLECT . . . . . 114  
EFMT3 and EEFMT3 support for LISTCAT . . . . . 115  
    EFMT3 and EEFMT3 subparameters in List tape volume entries sample output . . . . . 115

**Chapter 17. Tape drive and tape volume allocation modifications for 3592 Model E06 . . . . . 117**

Device support modifications . . . . . 117  
    IOS000I Message with Encryption Failure . . . . . 120  
SMS modifications. . . . . 121  
    In Data Class . . . . . 122  
    Overriding Attributes Defined in the Data Class . . . . . 122  
MVS device allocation modifications . . . . . 122  
JCL DD Statement Parameters and Equivalent Text Units for TS1130 . . . . . 123  
DSNAME Allocation Text Units for TS1130 . . . . . 124  
Verb Code 01 - Non-JCL Dynamic Allocation Functions for TS1130 . . . . . 124  
    Volume Interchange Specification - Key = '006F' . . . . . 124

**Chapter 18. ISMF modifications for TS1130 tape drive . . . . . 125**

Data class define and alter panels . . . . . 125  
Mountable tape volume list panel . . . . . 125

**Chapter 19. OCE modifications for TS1130 tape drive . . . . . 127**

Overview. . . . . 127  
SMS Managed Tape . . . . . 127  
Recording Technology Conflict . . . . . 127  
Multiple Recording Format Capability . . . . . 127  
Cartridge Reuse with DISP=OLD|SHR. . . . . 128  
OCE Tape Installation Exits. . . . . 128  
Multiple Recording Format Capability . . . . . 128  
IEZDEB (second DEB extension) . . . . . 128

**Chapter 20. DFSMSdss considerations for the TS1130 tape drive . . . . . 131**

DFSMSdss handling of hardware encryption . . . . . 131  
Updates to the DFSMSdss Application Programming Interface . . . . . 131

**Chapter 21. DFSMSShsm considerations for the TS1130 tape drive . . . . . 133**

Modifying your SMS data classes. . . . . 133  
Modifying your dump classes . . . . . 133  
Input tape utilization . . . . . 134  
Requesting information for encrypted volumes and tapes . . . . . 134  
    Displaying EFMT3 and EEFMT3 formatted volumes . . . . . 135  
    Displaying encrypted tape volumes . . . . . 135  
Requesting information for dump volumes . . . . . 135  
Specifying esoteric tape unit names to DFSMSShsm . . . . . 136  
Tape Hardware Emulation . . . . . 136  
Specifying how much of a tape DFSMSShsm uses . . . . . 136  
Using tape device naming conventions . . . . . 137  
Output tape selection. . . . . 138  
Output tape utilization . . . . . 138  
    Scratch Tapes . . . . . 138  
    Partial Tapes . . . . . 138  
Input tape utilization. . . . . 138  
    Reuse Capacity. . . . . 138  
    Mixed Device Esoteric Units . . . . . 139  
    Conversion of Tapes from D/T3490 to D/T3590 . . . . . 139  
Allowing DFSMSShsm to use the 3590-1 generic unit when it contains mixed track technology drives . . . . . 139  
Recovering overwritten encrypted tapes . . . . . 139  
DFSMSShsm tips . . . . . 139

**Chapter 22. DFSMSrmm modifications for TS1130 tape drive . . . . . 141**

EDGINERS ERASE function . . . . . 141  
    EXEC Parameters for EDGINERS. . . . . 141  
    SYSIN Commands for EDGINERS . . . . . 143  
DFSMSrmm TSO subcommands . . . . . 145  
    ADDVOLUME . . . . . 145  
    CHANGEVOLUME . . . . . 145  
    SEARCHVOLUME . . . . . 146  
    ADDDATASET . . . . . 147  
    CHANGEDATASET . . . . . 147  
    LISTDATASET . . . . . 148  
    LISTVOLUME . . . . . 148  
DFSMSrmm REXX variables . . . . . 149  
DFSMSrmm structured field introducers . . . . . 150  
    Compound SFI . . . . . 151  
DFSMSrmm macros . . . . . 152  
Creating Reports . . . . . 152

**Chapter 23. EREP modifications for 3592 Model E06 . . . . . 153**

TAPE subsystem exception report . . . . . 153  
Emulated device summary report . . . . . 153  
TAPE Media Informational Messages (MIMs). . . . . 154

**Chapter 24. JES3 modifications for TS1130 tape drive . . . . . 155**

**Chapter 25. OAM modifications for TS1130 tape drive . . . . . 157**

OAM library support . . . . . 157  
LCS external services changes . . . . . 157  
OAM installation exits changes . . . . . 158  
Operator command support changes . . . . . 158  
Mount processing change . . . . . 158  
OAM macro changes . . . . . 159  
Cartridge entry processing . . . . . 160  
OAM object tape support . . . . . 160  
KB Tracking . . . . . 160  
Sample Jobs . . . . . 161  
Object tape migration considerations . . . . . 163  
Object tape volume management support . . . . . 164

**Chapter 26. MVS IOS support for TS1130 tape drive . . . . . 165**

---

**Part 3. Encryption-capable TS1120 tape drive . . . . . 167**

**Chapter 27. Introduction for encryption-capable TS1120 tape drive. 169**

Encryption-capable TS1120 tape drive . . . . . 169  
Tape encryption for TS1120 . . . . . 170  
Key management for TS1120 . . . . . 171  
Key store for TS1120 . . . . . 171  
Encryption Key Manager (EKM) for TS1120 . . . . . 171  
In-band proxy for TS1120 . . . . . 173  
Management interfaces for TS1120 . . . . . 174  
Key label specifications for TS1120 . . . . . 174  
Volume label support for TS1120 . . . . . 175  
Volume recovery for TS1120 . . . . . 176  
Re-keying support for TS1120 . . . . . 176  
Media support for encryption-capable TS1120 tape drives . . . . . 176  
Performance scaling and segmentation for TS1120 . . . . . 179  
z/OS software support for the encryption-capable TS1120 tape drive . . . . . 180  
Using encryption-capable TS1120 tape drives in an IBM tape library environment . . . . . 182  
Using encryption-capable TS1120 tape drives in a stand-alone environment . . . . . 183  
Resolving recording technology conflicts for TS1120 . . . . . 183  
Implementation considerations for using encryption-capable TS1120 tape drives . . . . . 184

**Chapter 28. Migration to the software support for encryption-capable TS1120 tape drives . . . . . 187**

Understanding coexistence considerations for encryption-capable TS1120 . . . . . 187  
Preparing to install the software . . . . . 191  
Installing the appropriate PTFs . . . . . 191

Planning for DFSMS software support for the encryption-capable TS1120 tape drive . . . . . 191  
Implementing the DFSMS software support for the encryption-capable TS1120 tape drive . . . . . 198

**Chapter 29. Access method services (AMS) modifications . . . . . 203**

Enterprise Encrypted Format 2 (EEFMT2) . . . . . 203  
EEFMT2 Support for ALTER VOLUMEENTRY . . . . . 203  
EEFMT2 subparameter for ALTER VOLUMEENTRY . . . . . 203  
EEFMT2 Support for CREATE VOLUMEENTRY . . . . . 204  
EEFMT2 subparameter for CREATE VOLUMEENTRY . . . . . 204  
EEFMT2 Support for DCOLLECT . . . . . 204  
EEFMT2 subparameter for DCOLLECT . . . . . 204  
EEFMT2 Support for LISTCAT . . . . . 204  
EEFMT2 subparameter in List tape volume entries sample output . . . . . 205

**Chapter 30. Tape drive and tape volume allocation modifications for encryption-capable TS1120 tape drive. 207**

Device support modifications . . . . . 207  
IOS000I Message with Encryption Failure . . . . . 210  
DD statement changes . . . . . 212  
Parameter field . . . . . 212  
Overrides . . . . . 212  
SMS modifications . . . . . 213  
In Data Class . . . . . 213  
Overriding Attributes Defined in the Data Class . . . . . 213  
MVS device allocation modifications . . . . . 214  
JCL DD statement parameters and equivalent text units for TS1120 . . . . . 215  
DSNAME Allocation Text Units for TS1120 . . . . . 215  
Key Label 1 Specification - Key = '8023' . . . . . 216  
Key Label 2 Specification - Key = '8024' . . . . . 216  
Key Encode 1 Specification - Key = '8025' . . . . . 216  
Key Encode 2 Specification - Key = '8026' . . . . . 216  
Verb Code 01 - Non-JCL Dynamic Allocation Functions for TS1120 . . . . . 216  
Volume Interchange Specification - Key = '006F' . . . . . 216  
MVS Data Areas . . . . . 217

**Chapter 31. ISMF modifications for encryption-capable TS1120 tape drive. 219**

Data class define and alter panels for TS1120 . . . . . 219  
Mountable tape volume list panel . . . . . 219

**Chapter 32. OCE modifications for encryption-capable TS1120 tape drive. 221**

Overview . . . . . 221  
SMS Managed Tape . . . . . 221  
Recording Technology Conflict . . . . . 221  
Multiple Recording Format Capability . . . . . 222  
Encryption and Key Labels . . . . . 222  
Media Support . . . . . 223  
OCE Tape Installation Exits . . . . . 223  
OCE Messages . . . . . 224

OCE Encryption Abends . . . . .	225
---------------------------------	-----

**Chapter 33. DFSMSHsm considerations for the encryption-capable TS1120 tape drive . 227**

Modifying your SMS data classes . . . . .	227
Modifying your dump classes . . . . .	227
Input tape utilization . . . . .	228
Requesting information for encrypted volumes and tapes . . . . .	228
Displaying EEFMT2 formatted volumes . . . . .	229
Displaying encrypted tape volumes . . . . .	229
Requesting information for dump volumes . . . . .	229
Specifying esoteric tape unit names to DFSMSHsm	230
Tape Hardware Emulation . . . . .	230
Specifying how much of a tape DFSMSHsm uses	230
Using tape device naming conventions . . . . .	231
Output tape selection . . . . .	231
Output to Scratch Tapes . . . . .	231
Output to Partial Tapes . . . . .	231
Output tape utilization . . . . .	232
ACS Routines . . . . .	232
Allowing DFSMSHsm to use the 3590-1 generic unit when it contains mixed track technology drives . . . . .	232
Recovering overwritten encrypted tapes . . . . .	233
DFSMSHsm tips . . . . .	233

**Chapter 34. DFSMSdss considerations for the encryption-capable TS1120 tape drive . . . . . 235**

Planning to use hardware encryption for dump tapes . . . . .	235
Reviewing changes to SMS data classes . . . . .	235
Reviewing changes to DFSMSHsm dump classes	235
DFSMSdss handling of dump encryption requests	236
If double encryption is required . . . . .	237
DFSMSdss Stand Alone Restore program . . . . .	237
Updates to the Dump Volume Output Notification Exit (Exit 26) . . . . .	237

**Chapter 35. DFSMSrmm modifications for encryption-capable TS1120 tape drive . . . . . 239**

ADDVOLUME . . . . .	239
CHANGEVOLUME . . . . .	241
SEARCHVOLUME . . . . .	242
LISTVOLUME . . . . .	243
DFSMSrmm REXX variables . . . . .	244
DFSMSrmm structured field introducers . . . . .	244
DFSMSrmm macros . . . . .	245

**Chapter 36. EREP modifications for encryption-capable TS1120 tape drive . 247**

**Chapter 37. JES3 modifications for encryption-capable TS1120 tape drive . 249**

**Chapter 38. OAM modifications for encryption-capable TS1120 tape drive . 251**

OAM library support . . . . .	251
LCS external services changes . . . . .	251
OAM installation exits changes . . . . .	252
Operator command support changes . . . . .	252
Mount processing change . . . . .	252
OAM macro changes . . . . .	253
Cartridge entry processing . . . . .	253
OAM object tape support . . . . .	254
Object tape migration considerations . . . . .	254
Object tape volume management support . . . . .	255

**Chapter 39. MVS IOS support for TS1120 tape drive . . . . . 257**

Changes to MVS parmlib members . . . . .	257
Changes to MVS system commands . . . . .	257
Other administration tasks in support of MVS	
in-band tape encryption . . . . .	257
IOS Proxy Retry Logic . . . . .	258

---

**Part 4. 3592 Model E05 (also referred to as the TS1120). . . . . 259**

**Chapter 40. Introduction for 3592 Model E05 . . . . . 261**

IBM System Storage Tape System 3592 . . . . .	261
3592 Model E05 tape drive . . . . .	261
Write Once, Read Many (WORM) . . . . .	263
Performance scaling and segmentation for 3592 . . . . .	264
z/OS software support for the 3592 Model E05	
tape drive . . . . .	265
Using 3592 Model E05 tape drives in an IBM	
tape library environment . . . . .	267
Using 3592 Model E05 tape drives in a	
stand-alone environment . . . . .	268
Resolving recording technology conflicts for 3592	268
Implementation considerations for Using 3592	
Model E05 tape drives . . . . .	269

**Chapter 41. Migration to the software support for 3592 Model E05 tape drives. . . . . 271**

Understanding coexistence considerations for 3592	
Model E05 . . . . .	271
Preparing to install the software . . . . .	273
Installing the appropriate PTFs . . . . .	274
Planning for DFSMS software support for the 3592	
Model E05 . . . . .	274
Implementing the DFSMS software support for the	
3592 Model E05 . . . . .	279

## Chapter 42. Access method services (AMS) modifications for 3592 Model E05.

<b>E05.</b>	<b>283</b>
ALTER LIBRARYENTRY	283
ALTER LIBRARYENTRY command syntax	283
ALTER LIBRARYENTRY parameters	283
Altering a tape library entry example	285
ALTER VOLUMEENTRY	286
ALTER VOLUMEENTRY command syntax	286
ALTER VOLUMEENTRY parameters	287
Altering a volume entry example.	288
CREATE LIBRARYENTRY	289
CREATE LIBRARYENTRY command syntax	289
CREATE LIBRARYENTRY parameters	289
Creating a tape library entry example	291
CREATE VOLUMEENTRY	292
CREATE VOLUMEENTRY command syntax	292
CREATE VOLUMEENTRY parameters	293
Creating a VOLUME entry example.	294
DCOLLECT	295
DCOLLECT command syntax	295
DCOLLECT parameters	296
DCOLLECT example	297
LISTCAT	297
LISTCAT command syntax	297
LISTCAT parameters	297
List tape volume entries sample output.	298

## Chapter 43. Tape drive and tape volume allocation modifications for 3592 Model E05

<b>3592 Model E05</b>	<b>299</b>
Device support modifications	299
SMS modifications.	302
MVS device allocation modifications	303

## Chapter 44. ISMF modifications for 3592 Model E05

<b>3592 Model E05</b>	<b>305</b>
Data class define and alter panels for 3592 Model E05.	305
Mountable tape volume list panel	305
Tape library management panels	305

## Chapter 45. OCE modifications for 3592 Model E05

<b>3592 Model E05</b>	<b>307</b>
Overview.	307
SMS Managed Tape	307
Recording Technology Conflict	308
Dual Recording Capability	308
Segmentation Format.	308
Media Support	308
OCE Tape Installation Exits.	309

## Chapter 46. DFSMSShsm modifications for 3592 Model E05

<b>3592 Model E05</b>	<b>311</b>
Planning and installation	311
Input tape utilization	311
Output tape selection.	312
Output tape utilization	312

Scratch tapes	312
Partial tapes.	312
Reuse capacity table	313
Displaying EFMT2 formatted volumes	313
WORM tape cartridge rejection at OPEN time	313
Aggregate backup and recovery (ABARs) with WORM tape cartridge	313
DFSMSShsm tips	313

## Chapter 47. DFSMSrmm modifications for 3592 Model E05

<b>3592 Model E05</b>	<b>317</b>
ADDVOLUME	318
CHANGEVOLUME	319
SEARCHVOLUME	319
DFSMSrmm REXX variables	320
DFSMSrmm structured field introducers	320
DFSMSrmm macros	320
Volume Not in Library Support	321

## Chapter 48. EREP modifications for 3592 Model E05

<b>3592 Model E05</b>	<b>323</b>
Tape subsystem exception report	323
Event history report	323
System error summary report	324
Emulated device summary report	324

## Chapter 49. JES3 modifications for 3592 Model E05

<b>3592 Model E05</b>	<b>327</b>
-----------------------	------------

## Chapter 50. OAM modifications for 3592 Model E05

<b>3592 Model E05</b>	<b>329</b>
OAM library support.	329
LCS external services changes	329
OAM installation exits changes	329
Operator command support changes	330
Scratch mount considerations	331
Scratch threshold processing change.	331
OAM macro changes	331
Volume not in library installation exit enhancement	332
Cartridge entry processing	333
Tape device selection information (TDSI)	
Migration Considerations	334
OAM object tape support	334
Object tape migration considerations	336
Object tape volume management support	336

## Part 5. 3592 Model J

### Chapter 51. Introduction for 3592 Model J

<b>3592 Model J</b>	<b>339</b>
IBM System Storage Tape System 3592	339
3592 Model J tape drive	339
Write Once, Read Many (WORM)	340
z/OS software support for the 3592 Model J tape drive	341
Using 3592 Model J tape drives in an IBM tape library environment	343



Using 3592 Model J tape drives in a stand-alone environment. . . . .	344
Implementation considerations for Using 3592 Model J tape drives . . . . .	344

**Chapter 52. Migration to the software support for 3592 Model J tape drives . 347**

Understanding coexistence considerations for 3592 Model J1A . . . . .	347
Preparing to install the software . . . . .	350
Installing the appropriate PTFs . . . . .	350
Planning for DFSMS software support for the 3592 Model J . . . . .	350
Implementing the DFSMS software support for the 3592 Model J . . . . .	357

**Chapter 53. Access method services (AMS) modifications for 3592 Model J . 361**

ALTER LIBRARYENTRY . . . . .	361
ALTER LIBRARYENTRY command syntax . . . . .	361
ALTER LIBRARYENTRY parameters . . . . .	361
Altering a tape library entry example . . . . .	363
ALTER VOLUMEENTRY . . . . .	363
ALTER VOLUMEENTRY command syntax . . . . .	364
ALTER VOLUMEENTRY parameters . . . . .	364
Altering a volume entry example. . . . .	365
CREATE LIBRARYENTRY . . . . .	366
CREATE LIBRARYENTRY command syntax . . . . .	366
CREATE LIBRARYENTRY parameters . . . . .	366
Creating a tape library entry example . . . . .	368
CREATE VOLUMEENTRY . . . . .	369
CREATE VOLUMEENTRY command syntax . . . . .	369
CREATE VOLUMEENTRY parameters . . . . .	369
Creating a VOLUME entry example. . . . .	371
DCOLLECT . . . . .	371
DCOLLECT command syntax . . . . .	371
DCOLLECT parameters . . . . .	372
DCOLLECT example . . . . .	373
LISTCAT . . . . .	373
LISTCAT command syntax . . . . .	373
LISTCAT parameters . . . . .	374
List tape volume entries sample output. . . . .	374

**Chapter 54. Tape drive and tape volume allocation modifications for 3592 Model J . 377**

Device support modifications . . . . .	377
SMS modifications. . . . .	380
MVS device allocation modifications . . . . .	380

**Chapter 55. ISMF modifications for 3592 Model J . 383**

Data class define and alter panels for 3592 Model J . . . . .	383
Mountable tape volume list panel . . . . .	383
Tape library management panels . . . . .	383

**Chapter 56. OCE modifications for 3592 Model J . 385**

SMS-managed tape configuration database (TCDB) volume record . . . . .	385
SMS-managed tape (TVR) volume record . . . . .	385
DEVSUPxx parmlib member options . . . . .	386
Open/EOV Volume Security and Verification Exit . . . . .	386
IFGTEP macro . . . . .	386
OCE Tape Installation Exits. . . . .	387

**Chapter 57. DFSMSHsm modifications for 3592 Model J . 389**

Output tape selection. . . . .	389
Output tape utilization . . . . .	389
Reuse capacity table . . . . .	390
WORM tape cartridge rejection at OPEN time . . . . .	390
Aggregate backup and recovery (ABARs) with WORM tape cartridge . . . . .	390
DFSMSHsm tips . . . . .	390

**Chapter 58. DFSMSRmm modifications for 3592 Model J . 393**

ADDVOLUME . . . . .	393
CHANGEVOLUME . . . . .	394
SEARCHVOLUME . . . . .	395
DFSMSRmm REXX variables . . . . .	395
DFSMSRmm structured field introducers . . . . .	395
DFSMSRmm macros . . . . .	396
DFSMSRmm return codes and reason codes . . . . .	397
Parmlib Member EDGRMMxx VLPOOL MASTEROVERWRITE command. . . . .	397
SMSACS Input Variables for RMMVRS and RMMPOOL ACS Calls . . . . .	398
Using DFSMSRmm to manage WORM tapes . . . . .	398
Defining WORM tapes to DFSMSRmm . . . . .	399
Segregating WORM tapes in separate scratch pools . . . . .	399
Changing the status of WORM tapes . . . . .	399
Identifying WORM tapes ready for destruction . . . . .	399

**Chapter 59. EREP modifications for 3592 Model J . 401**

Tape subsystem exception report . . . . .	401
Event history report . . . . .	401
System error summary report . . . . .	402
Emulated device summary report . . . . .	402

**Chapter 60. JES3 modifications for 3592 Model J . 405**

**Chapter 61. OAM modifications for 3592 Model J . 407**

OAM library support. . . . .	407
LCS external services changes . . . . .	407
OAM installation exits changes . . . . .	407
Operator command support changes . . . . .	408
OAM macro changes . . . . .	409
Scratch mount considerations . . . . .	411

3592 drive level and allocation considerations	411
OAM object tape support	411
Object tape data set low-level qualifier enhancement	413
Object tape volume management support	414
MOVEVOL command	414

---

**Part 6. Appendixes . . . . . 415**

**Appendix. Accessibility . . . . . 417**

Using assistive technologies	417
Keyboard navigation of the user interface	417

Dotted decimal syntax diagrams	417
--------------------------------	-----

**Notices . . . . . 421**

Policy for unsupported hardware	422
Minimum supported hardware	423
Programming interface information	423
Trademarks	423

**Glossary . . . . . 425**

**Index . . . . . 431**

---

## Figures

1. DS QT,960 output . . . . .	38	22. DS QT,962,MED output . . . . .	300
2. DS QT,960,MED output . . . . .	38	23. DS QT,940 output . . . . .	301
3. TAPE subsystem exception report . . . . .	73	24. DS QT,DA0 output. . . . .	301
4. Emulated device summary report . . . . .	73	25. DS QT,B60,MED message . . . . .	301
5. TAPE Media Informational Messages (MIMs) . . . . .	74	26. DS QT,DA0,MED message . . . . .	301
6. DS QT,960 output . . . . .	118	27. Contents of the shipped table: TAPEUNITS . . . . .	322
7. DS QT,960,MED output . . . . .	118	28. Partial tape subsystem exception report . . . . .	323
8. EDGINERS EXEC Parameters . . . . .	142	29. Partial event history report . . . . .	324
9. EDGINERS SYSIN Commands . . . . .	144	30. Partial system error summary report . . . . .	324
10. TAPE subsystem exception report. . . . .	153	31. Partial emulated device summary report . . . . .	325
11. Emulated device summary report. . . . .	153	32. LISTCAT output . . . . .	374
12. TAPE Media Informational Messages (MIMs) . . . . .	154	33. DEVSERV QTAPE MED display content . . . . .	378
13. CBRSMKBO SAMPLIB Member . . . . .	162	34. DS QT,962,MED output . . . . .	378
14. DEVSERV QTAPE MED display content . . . . .	208	35. DS QT,940,MED output . . . . .	378
15. DS QT,962,MED output . . . . .	208	36. DS QT,DA0,MED output. . . . .	379
16. DS QT,940 output . . . . .	209	37. DS QT,B60,MED message . . . . .	379
17. DS QT,DA0 output. . . . .	209	38. DS QT,DA0,MED message . . . . .	379
18. DS QT,B60,MED message . . . . .	209	39. Partial event history report . . . . .	401
19. DS QT,DA0,MED message . . . . .	209	40. Partial event history report . . . . .	402
20. LISTCAT output for 3592 Model E05 . . . . .	298	41. Partial system error summary report . . . . .	402
21. DEVSERV QTAPE MED display content . . . . .	300	42. Partial emulated device summary report . . . . .	403



---

## Tables

1. Syntax conventions . . . . .	xviii	34. IFGTEP fields for the installation exit main parameter list . . . . .	223
2. Components that provide software support for the TS1140 tape drive . . . . .	10	35. IFGTEP fields for the installation exit file end on volume parameter list . . . . .	224
3. Coexistence migration tasks for TS1140 tape drives . . . . .	16	36. Tape device naming conventions . . . . .	231
4. TS1140 tape drive planning considerations	19	37. DFSMSDss handling of dump encryption requests . . . . .	236
5. Format swaps allowed for TS1140 . . . . .	38	38. ADREID0 mapping . . . . .	237
6. Error codes for control unit failures . . . . .	40	39. Changed TSO subcommand REXX variables	244
7. Dynamic allocation (DALINCHG) parameter values for tape cartridge media types . . . . .	42	40. Changed structured field introducers	245
8. IFGTEP fields for the installation exit parameter list . . . . .	48	41. DFSMSrmm mapping macro changes	245
9. Tape device naming conventions . . . . .	57	42. OAM mapping macro changes . . . . .	253
10. Changed TSO subcommand REXX variables	67	43. Components that provide software support for the 3592 Model E05 tape drive . . . . .	265
11. Changed structured field introducers . . . . .	68	44. Coexistence migration tasks for 3592 Model E05 . . . . .	272
12. DFSMSrmm mapping macro changes . . . . .	69	45. 3592 Model E05 planning considerations	274
13. OAM mapping macro changes . . . . .	80	46. Dynamic allocation (DALINCHG) parameter values for tape cartridge media types . . . . .	303
14. Components that provide software support for the TS1130 tape drive . . . . .	95	47. IFGTEP fields for the installation exit main parameter list . . . . .	309
15. Coexistence migration tasks for TS1130 tape drives . . . . .	100	48. DFSMSrmm media names . . . . .	318
16. TS1130 tape drive planning considerations	103	49. Changed TSO subcommand REXX variables	320
17. Format swaps allowed for TS1130. . . . .	119	50. Changed structured field introducers	320
18. Error codes for control unit failures . . . . .	120	51. DFSMSrmm mapping macro changes	320
19. Dynamic allocation (DALINCHG) parameter values for tape cartridge media types . . . . .	122	52. OAM mapping macro changes . . . . .	331
20. IFGTEP fields for the installation exit main parameter list . . . . .	128	53. Library table column descriptions. . . . .	335
21. ADREID0 Mapping . . . . .	132	54. Components that provide software support for the 3592 Model J tape drive . . . . .	342
22. Tape device naming conventions . . . . .	137	55. Coexistence migration tasks. . . . .	348
23. Changed TSO subcommand REXX variables	149	56. 3592 Model J planning considerations	351
24. Changed structured field introducers	151	57. Dynamic allocation (DALINCHG) parameter values for tape cartridge media types . . . . .	381
25. DFSMSrmm mapping macro changes	152	58. IFGTEP fields for the installation exit main parameter list . . . . .	387
26. OAM mapping macro changes. . . . .	159	59. IFGTEP fields for the installation exit main parameter list . . . . .	387
27. Components that provide software support for the encryption-capable TS1120 tape drive .	180	60. DFSMSrmm media names . . . . .	394
28. Coexistence migration tasks for encryption-capable TS1120 tape drives . . . . .	188	61. Changed TSO subcommand REXX variables	395
29. Encryption-capable TS1120 tape drive planning considerations . . . . .	192	62. Changed structured field introducers	396
30. Error codes for control unit failures . . . . .	211	63. DFSMSrmm mapping macro changes	396
31. Dynamic allocation (DALINCHG) parameter values for tape cartridge media types . . . . .	214	64. New return codes and reason codes . . . . .	397
32. JCL DD Statement Parameters and Equivalent Text Units. . . . .	215	65. OAM mapping macro changes. . . . .	409
33. Verb code 01 (dsname allocation) – text unit keys, mnemonics, and functions . . . . .	215	66. Library table column descriptions. . . . .	413



---

## About this document

This document describes z/OS® Version 2 Data Facility Storage Management Subsystem (DFSMS) software support for the 3592 family of tape drives. It is designed to help system operators, system programmers, and application programmers understand, install, and use the IBM® System Storage® 3592 software support. The IBM 3592 family includes the TS1140 (3592 Model E07), TS1130 (3592 Model E06), the encryption-capable TS1120 (the enhanced 3592 Model E05), the original 3592 Model E05, and the 3592 Model J1A tape drives. This document:

- Introduces the functional features of the 3592 family of drives (3592 Model E07 (TS1140), 3592 Model E06 (TS1130), 3592 Model E05 (TS1120), and the 3592 Model J1A)).
- Describes the modifications made to z/OS DFSMS functional components and related licensed programs in support of the drive.
- Describes migration tasks and coexistence tasks for implementing the tape drives.

For information about accessibility features of z/OS, for users who have a physical disability, see “Accessibility,” on page 417.

---

## Required product knowledge

To use this document effectively, you should be familiar with the following software products:

- Access method services (AMS)
- Data facility sort (DFSORT)
- Device support/asynchronous operations manager (AOM)
- DFSMS data set services (DFSMSdss)
- DFSMS hierarchical storage manager (DFSMSHsm)
- DFSMS removable media manager (DFSMSRmm)
- One of:
  - IBM Security Key Lifecycle Manager
  - Tivoli Key Lifecycle Manager (TKLM)
  - Encryption Key Manager component for the Java™ platform (EKM) (for TS1120 and TS1130 only)
- Environmental recording, editing, and printing (EREP)
- Input/output supervisor (IOS)
- Interactive storage management facility (ISMF)
- MVS allocation
- MVS job entry subsystem 3 (JES3)
- Open/close/end-of-volume (OCE)
- Object access method (OAM)
- Storage management subsystem (SMS)

---

## Referenced information centers

The following information centers are referenced in this document:

- IBM System Storage 3592-C07 Controller Customer Information Center ([http://pic.dhe.ibm.com/infocenter/etc/cust/index.jsp?topic=%2Fcom.ibm.storage.etc.doc%2Fwelcome%2Fetc\\_ic\\_welcome.html](http://pic.dhe.ibm.com/infocenter/etc/cust/index.jsp?topic=%2Fcom.ibm.storage.etc.doc%2Fwelcome%2Fetc_ic_welcome.html))
- IBM 3592 Model E07 Tape Drive Information Center (<http://pic.dhe.ibm.com/infocenter/jagdrive/cust/index.jsp>)

---

## z/OS information

This information explains how z/OS references information in other documents and on the web.

When possible, this information uses cross-document links that go directly to the topic in reference using shortened versions of the document title. For complete titles and order numbers of the documents for all products that are part of z/OS, see *z/OS Information Roadmap*.

To find the complete z/OS library, including the z/OS Information Center, see z/OS Internet Library (<http://www.ibm.com/systems/z/os/zos/bkserv/>).

---

## Notational conventions

This section explains the notational conventions used in this document.

### How to read syntax diagrams

There is one basic rule for reading the syntax diagrams: Follow only one line at a time from the beginning to the end and code everything you encounter on that line.

The following rules apply when reading syntax diagrams:

- Read the syntax diagrams from left to right and from top to bottom.
- Each syntax diagram begins with a double arrowhead (▶▶) and ends with opposing arrows (◀◀).
- An arrow (→) at the end of a line indicates that the syntax continues on the next line. A continuation line begins with an arrow (▶→).
- Commands and keywords are shown in uppercase letters.
- Some commands and keywords have alternative abbreviations; these appear as part of the stack for that command or keyword. For example, the alternative abbreviation for **DISPLAY** is **D**.

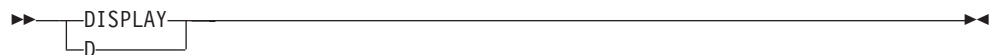

- Where you can choose from two or more keywords, the choices are stacked one above the other. If one choice within the stack lies on the main path, a keyword is required, and you must choose one. In the following example you must choose either **DETAIL** or **STATUS**.

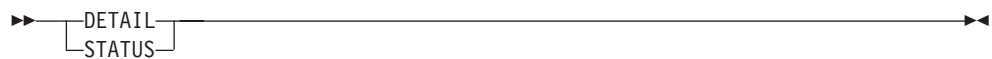

- If a stack is placed below the main path, a keyword is optional, and you can choose one or none. In the following example, **PURGE**, **KEEP**, and **LOCATION** are optional keywords. You can choose any one of the three.





- Where you can choose from two or more keywords and one of the keywords appears above the main path, that keyword is the default. You may choose one or the other of the keywords, but if none is entered, the default keyword is automatically selected. In the following example you may choose either **DETAIL** or **STATUS**. If neither is chosen, **STATUS** is automatically selected.



- Words or names in italicized, lowercase letters represent information that you supply. The values of these variables may change depending on the items to which they refer. For example, *volser* refers to the serial number of a volume, while *storgrp\_name* refers to the name of a storage group.
- You must provide all items enclosed in parentheses ( ). You must include the parentheses. In the following example, you must supply the volume serial number (*volser*) and it must be enclosed in parentheses.

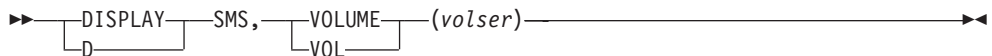

You would code this as follows:

```
D SMS,VOL(volser)
```

The variable *volser* is the serial number of the volume you wish to display.

- The repeat symbol shown below indicates that you can specify keywords and variables more than once. The repeat symbol appears above the keywords and variables that can be repeated. For example, when a comma appears in the repeat symbol, you must separate repeated keywords or variables with a comma.

In the following example, you may specify the *library\_name* and one or more system identification numbers (*system\_ID*) that are separated by commas. You must enclose the name of the library and all of the system IDs in parentheses.

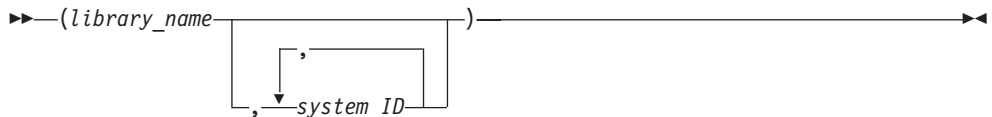

You would code this as follows:

```
(library_name, system_ID, system_ID, system_ID)
```

The variable *library\_name* is the name of the library you are working with, and *system\_ID* names three different instances of system identification numbers.

## How to read syntax conventions

This section describes how to read syntax conventions. It defines syntax notations and provides syntax examples that contain these items.

Table 1. Syntax conventions

Notation	Meaning	Book syntax example	Sample entry
Apostrophes	Apostrophes indicate a parameter string and must be entered as shown.	SEND 'message',NOW	SEND 'listings ready',NOW
Comma	Commas must be entered as shown.	DISPLAY C,K	DISPLAY C,K
Ellipsis ...	Ellipsis indicates that the preceding item or group of items can be repeated one or more times. Do not enter the ellipsis.	VARY (devspec[,devspec]...),ONLINE	VARY (282,283,287),ONLINE
Parentheses and special characters	Parentheses and special characters must be entered as shown.	DUMP COMM=(text)	DUMP COMM=(PAYROLL)
Underline	Underline indicates a default option. If you select an underlined alternative, you do not have to specify it when you enter the command.	<u>K T</u> [,REF ] [,UTME=nnn]	K T
Lowercase parameter	Lowercase indicates a variable term. Substitute your own value for the item.	MOUNT devnum	MOUNT A30 or mount a30
Uppercase parameter	Uppercase indicates the item must be entered using the characters shown. Enter the item in either upper or lowercase.	DISPLAY SMF	DISPLAY SMF or display smf
Single brackets	Single brackets represent single or group-related items that are optional. Enter one or none of these items.	DISPLAY DMN[=domainum]	DISPLAY DMN=5
Stacked brackets	Stacked brackets represent group-related items that are optional. Enter one or none of these items.	[TERMINAL] [NOTERMINAL]	NOTERMINAL
Single braces	Single braces represent group-related items that are alternatives. You must enter one of the items. You cannot enter more than one.	{COMCHECK   COMK}	COMK
Stacked braces	Stacked braces represent group related items that are alternatives. You must enter one of the items. You cannot enter more than one.	MN {DSNAME} {SPACE} {STATUS}	MN SPACE

Table 1. Syntax conventions (continued)

Notation	Meaning	Book syntax example	Sample entry
Or-bar ( )	An or-bar indicates a mutually-exclusive choice. When used with brackets, enter one or none of the items. When used with braces, you must enter one of the items.	ACTIVATE   RECOVER=SOURCE	RECOVER=SOURCE
Stacked items with or-bars ( ) and brackets	Stacked items with or-bars indicates a mutually-exclusive choice. Enter one or none of these items.	CD RESET [ ,SDUMP   ,SYSABEND   ,SYSUDUMP   ,SYSMDUMP   , <u>ALL</u> ]	CD RESET ,SYSUDUMP



---

## How to send your comments to IBM

We appreciate your input on this publication. Feel free to comment on the clarity, accuracy, and completeness of the information or provide any other feedback that you have.

Use one of the following methods to send your comments:

1. Send an email to [mhvrcfs@us.ibm.com](mailto:mhvrcfs@us.ibm.com).
2. Send an email from the "Contact us" web page for z/OS (<http://www.ibm.com/systems/z/os/zos/webqs.html>).
3. Mail the comments to the following address:  
IBM Corporation  
Attention: MHVRCFS Reader Comments  
Department H6MA, Building 707  
2455 South Road  
Poughkeepsie, NY 12601-5400  
US
4. Fax the comments to us, as follows:  
From the United States and Canada: 1+845+432-9405  
From all other countries: Your international access code +1+845+432-9405

Include the following information:

- Your name and address.
- Your email address.
- Your telephone or fax number.
- The publication title and order number:  
z/OS DFSMS Software Support for IBM System Storage TS1140, TS1130, and TS1120 Tape Drives (3592)  
SC23-6854-00
- The topic and page number that is related to your comment.
- The text of your comment.

When you send comments to IBM, you grant IBM a nonexclusive right to use or distribute the comments in any way appropriate without incurring any obligation to you.

IBM or any other organizations use the personal information that you supply to contact you only about the issues that you submit.

---

## If you have a technical problem

Do not use the feedback methods that are listed for sending comments. Instead, take one of the following actions:

- Contact your IBM service representative.
- Call IBM technical support.
- Visit the IBM Support Portal at z/OS support page (<http://www.ibm.com/systems/z/support/>).



---

## Summary of changes

---

### **z/OS Version 2 Release 1 summary of changes**

See the following publications for all enhancements to z/OS Version 2 Release 1 (V2R1):

- *z/OS Planning for Installation*
- *z/OS Introduction and Release Guide*
- *z/OS Summary of Message and Interface Changes*
- *z/OS Migration*





---

## **Part 1. TS1140 tape drive**



---

## Chapter 1. Introduction for TS1140 tape drive

Like the TS1120 and TS1130 tape drives, the TS1140 provides a tape encryption capability. Data encryption is an important tool for protecting against the possible misuse of confidential information that could occur should tapes be lost or stolen. Unless the possessor of the tape has the required key, any encrypted data on the tape will remain confidential and will be unreadable.

This topic describes the IBM System Storage TS1140 (3592 Model E07, 3592-4E) tape drives and the z/OS software support needed to use them.

---

### TS1140 tape drive

Unlike the TS1120 (3592 Model E05), which can be either encryption capable (3592-2E) or not (3592-2), the TS1140 (3592 Model E07) is always capable of encryption when used by z/OS and always reports as 3592-4E. References in this document to “encryption-capable” means that the encryption feature in the drive had been enabled and the drive is capable of encrypting. In other documents, this may be referred to as “encryption-enabled”.

The TS1140 tape drive offers these features:

- Creates tapes for archive files.
- Optionally creates encrypted tapes.
- Backs up and restores systems in case of system or disk storage problems.
- Stores high-speed, high-capacity sequential application data sets.
- Stores temporary data sets.
- Satisfies off-site data storage for disaster recovery.
- Provides data interchange (MEDIA9 and MEDIA10 cartridges) with other systems that use 3592 Model E07 (TS1140) and 3592 Model E06 (TS1130) subsystems. The 3592 Model E07 can also read MEDIA9 and MEDIA10 cartridges written in the EFMT2 and EEFMT2 formats, as well as MEDIA5, MEDIA6, MEDIA7, and MEDIA8 cartridges written in EFMT1, EFMT2, EEFMT2, EFMT3, and EEFMT3 formats.
- Supports WORM (write once, read many) tape data cartridges whose data cannot be altered.

The advantages of the TS1140 tape drive over other encryption methods, such as host-based software encryption, are that it:

- Permits full performance of the tape device when encryption is enabled.
- Permits encryption to be performed after compression.
- Avoids performance penalties in the host.

---

### Tape encryption

The TS1140 tape drive supports encryption of media tape cartridges. The existing z/OS DFSMS support for tape subsystem encryption (introduced with the TS1120) allows you to specify by data class that data is to be encrypted. In addition to this, the key label-related information that is used to encrypt the data key (of a tape cartridge) can be specified through the DD statement (JCL, dynamic allocation, and TSO ALLOCATE), data class, or encryption key manager defaults.

**Note:** Encryption key managers are applications that work with IBM encryption-enabled tape drives in generating, protecting, storing and maintaining

encryption keys that are used to encrypt information being written to and decrypt information being read from tape media. IBM offers two encryption key managers that support the TS1140:

- Tivoli Key Lifecycle Manager (TKLM). The TS1140 requires, at a minimum, V2.0 of TKLM. More information on this offering can be found on the TKLM website: <http://www.ibm.com/software/tivoli/products/key-lifecycle-mgr/>
- IBM Security Key Lifecycle Manager for z/OS V1.1. More information about this offering can be found at [http://publib.boulder.ibm.com/infocenter/tivihelp/v2r1/index.jsp?topic=/com.ibm.tivoli.isklm.doc\\_11/ic-homepage.html](http://publib.boulder.ibm.com/infocenter/tivihelp/v2r1/index.jsp?topic=/com.ibm.tivoli.isklm.doc_11/ic-homepage.html).

A third IBM offering, the IBM Encryption Key Manager for Java platform (EKM) does not support the TS1140 (it supports only the TS1120 and the TS1130). References in this book to an “encryption key manager” for use with a TS1140 apply generically to either TKLM or IBM Security Key Lifecycle Manager.

The communication path to the encryption key manager is across TCP/IP, with the choice to go either in-band or out-of-band for the key management flow. With out-of-band key management, the communication path to the encryption key manager is handled by the control unit going directly to the encryption key manager. Then, for in-band key management, the communication path to the encryption key manager is handled across ESCON/FICON, with an IOS proxy interface then handling the key exchange (across TCP/IP) with the encryption key manager.

Unless directed otherwise, a TS1140 tape drive records in the new non-encryption enterprise format 4 (EFMT4). It can also record in the new encryption specific recording format (enterprise encrypted format 4 (EEFMT4)). The EFMT4 and EEFMT4 recording formats are supported on the 3592 media types MEDIA9, MEDIA10, MEDIA11, MEDIA12, and MEDIA13. The existing Performance Scaling and Performance Segmentation data class options can also be used with the EFMT4 and EEFMT4 recording formats on MEDIA 9 and MEDIA11. The capacities of tapes written in EFMT4 and EEFMT4 are the same.

A TS1140 tape drive can also read the existing EFMT1 recording format on media types MEDIA5 through MEDIA8 and the EFMT2, EFMT3, EEFMT2, and EEFMT3 recording formats on media types MEDIA5 through MEDIA10. A TS1140 tape drive can be explicitly directed to write from beginning of tape (BOT) in the EFMT3 or EEFMT3 recording format on media types MEDIA9 and MEDIA10.

When writing from the beginning of tape (BOT), an encryption-capable TS1140 tape drive will, by default, record in the non-encryption recording format (EFMT4). Unless explicitly requested through data class to record in the lower recording format (EFMT3 or EEFMT3) or the new encryption format (EEFMT4), the non-encryption format EFMT4 will be assumed and explicitly set during OPEN processing. When writing from the beginning of the tape (file sequence 1, DISP=OLD or DISP=SHR for volume reuse), since this processing does not go through the data class ACS routine, OPEN processing will determine whether encryption (EEFMT3 or EEFMT4) had previously been used and ensure that encryption is requested for this next usage of the tape. So, if the previous usage of the tape was encrypted, OPEN will explicitly set the new encryption format (EEFMT4) and will obtain and pass the volume’s existing key management-related information to the drive (key label and encoding mechanism). In this case, a new data key is generated and used. However, the volume’s existing key management-related information is used to encrypt the data key. This is similar to the way that the encryption formats EEFMT2 and EEFMT3 are handled by the TS1120 and TS1130 encryption support. This is also consistent with TS1120 and

TS1130 drives, where, on reuse, if encryption was not used, the highest non-encryption recording format is specified.

For an encrypted tape cartridge, the cartridge stores both the encrypted user data and the critical key management-related information needed to interact with the encryption key manager when decrypting data on the cartridge. A mix of data written in encrypted and non-encrypted formats is not supported on the same tape cartridge. Whether the data on a cartridge is written in encrypted format is determined during OPEN processing, when the first file sequence on the tape is written. If the first file written to a tape is in the encrypted format; all subsequent files written to that same tape cartridge will be written in the encrypted format. All files written to a cartridge in the encrypted format are encrypted using the same data key. The exception to this is the volume label structure for the first file sequence, which is encrypted using a key known to all encryption capable 3592 drives, which means it is effectively in the clear.

In the TS1140 tape drive environment (whether system-managed or not), when writing from the beginning of tape (file sequence 1, DISP=NEW), to request encryption format, EEFMT4 (or EEFMT3 for downward compatibility) is specified in the data class. OPEN processing passes key management-related information (such as the key labels) to the drive for subsequent communication with the encryption key manager.

To select encryption for a cartridge, do these steps:

1. Define a data class that requests encryption.
2. Modify or create ACS routines to associate the tape output functions using encryption with a data class that requests encryption.
3. Specify the appropriate key labels either through the DD statement (JCL, dynamic allocation, or TSO allocate), data class, or by using encryption key manager established defaults.

---

## Key management for TS1140

Key Management consists of a number of elements including:

- A key store where the keys to encrypt and decrypt the data key are securely kept and readily available.
- An encryption key manager that communicates with the drive through the designated key management path (in-band or out-of-band).
- Ability of the tape drive to request and process (with the encryption key manager) key management information.
- A management interface for configuring and managing the encryption key manager.

### Key store for TS1140

Other than the original Encryption Key Manager (EKM) not supporting the TS1140, key store for TS1140 is unchanged from TS1120. See “Key store for TS1120” on page 171 for more information.

### IBM Security Key Lifecycle Manager

The IBM Security Key Lifecycle Manager can be used with the TS1140 (3592 Model E07), as well as the TS1130 (3592 Model E06) and the TS1120 (3592 Model E05) tape encrypting drives. Like the original Encryption Key Manager (EKM), the IBM Security Key Lifecycle Manager serves data keys to the tape drive. The IBM

Security Key Lifecycle Manager is closer in functionality to the original Encryption Key Manager (EKM) and does not have the advanced key management functionality and GUI provided by the TKLM. Customers using the Encryption Key Manager (EKM) or the Tivoli Key Lifecycle Manager (TKLM) can migrate to the IBM Security Key Lifecycle Manager based on their key management needs. For additional information, see the IBM Security Key Lifecycle Manager Information Center.

## Tivoli Key Lifecycle Manager (TKLM)

The Tivoli® Key Lifecycle Manager (TKLM) can be used with the new TS1140 (3592 Model E07), as well as the existing TS1130 (3592 Model E06) and the TS1120 (3592 Model E05) tape encrypting drives. Like the Encryption Key Manager (EKM), the TKLM serves data keys to the tape drive. TKLM focuses on ease of use and provides a graphical interface (GUI) to help with the installation and configuration of the key manager. It also allows for the creation and management of the key encrypting keys (certificates). Customers using the Encryption Key Manager (EKM) can migrate to TKLM. For additional information on TKLM, see the IBM Tivoli Key Lifecycle Manager Information Center.

## Encryption Key Manager (EKM)

Key manager support for TS1140 is unchanged from TS1120, except:

- The original Encryption Key Manager (EKM) does not support the TS1140.
- EEFMT3 or EEFMT4 may be specified for the recording format.

See “Encryption Key Manager (EKM) for TS1120” on page 171 for more information.

The original Encryption Key Manager (EKM) can be used with the TS1120 and the TS1130 Tape Drives. The TS1140, however, requires the Tivoli Key Lifecycle Manager (TKLM) Version 2 or the IBM Security Key Lifecycle Manager. Host software including the IOS proxy has no direct knowledge of which key manager is being used. Specification of the key manager is handled using the EKM keyword on existing IOS commands regardless of which key manager is being used.

## In-band proxy for TS1140

In-band proxy for TS1140 is unchanged from TS1120. See “In-band proxy for TS1120” on page 173 for more information.

**Note:** For IPv6 support (with the IOS proxy) refer to APAR OA22271. This support was added after the initial tape encryption support for the TS1120.

## Management interfaces for TS1140

Management interfaces for TS1140 is unchanged from TS1120. See “Management interfaces for TS1120” on page 174 for more information.

---

## Key label specifications for TS1140

Key label specifications for TS1140 is unchanged from TS1120, except that EEFMT4 (EE4) or EEFMT3 (EE3) may be specified for the recording format. See “Key label specifications for TS1120” on page 174 for more information.

---

## Volume label support for TS1140

Volume label support for TS1140 is unchanged from TS1120. See “Volume label support for TS1120” on page 175 for more information.

---

## Volume recovery for TS1140

Volume recovery support for TS1140 is unchanged from TS1120. See “Volume recovery for TS1120” on page 176 for more information.

---

## Re-keying support for TS1140

Re-keying support (introduced after the initial tape encryption support for the TS1120 (APAR OA20076), also applies to the TS1140. See “Re-keying support for TS1120” on page 176 for more information on what it means to re-key a tape cartridge. Re-keying is initiated through the IEHINITT utility with the REKEY option.

---

## Recording format and media support for TS1140 tape drives

The TS1140 tape drive reads and writes in the new EFMT4 (enterprise format 4) and EEFMT4 (enterprise encrypted format 4) recording formats (MEDIA9 through MEDIA13), as well as the existing EFMT3 (enterprise format 3) and EEFMT3 (enterprise encrypted format 3) recording formats (MEDIA9 and MEDIA10). The TS1140 tape drive can also read (but not write) the older EFMT2 and EEFMT2 recording formats (MEDIA9 and MEDIA10), and media types MEDIA5 through MEDIA8 (EFMT1, EFMT2, EEFMT2, EEFMT3, and EEFMT3). EEFMT4 records data in an encrypted format. EEFMT4 provides the same capacity as EFMT4.

Ensure that any partially filled MEDIA9 or MEDIA10 tapes written in EFMT2 or EEFMT2, and MEDIA5 through MEDIA8 tapes written in EFMT1, EFMT2, EEFMT2, EFMT3, or EEFMT3 are marked-full (as appropriate), because they cannot be extended on the TS1140.

The IBM System Storage TS1140 tape drive uses the following IBM System Storage family of tape media.

- MEDIA9 - The IBM Enterprise Extended Tape Cartridge (MEDIA9) physical media. MEDIA9 requires the EFMT4, EFMT3, or EEFMT3 recording format, and provides an uncompressed capacity of 1600 GB with EFMT4 or EEFMT4 (1000 GB with EFMT3 or EEFMT3). Provides a compressed capacity of 4800 GB with EFMT4 or EEFMT4 (3000 GB with EFMT3 or EEFMT3), assuming a 3:1 compression ratio (the compression ratio depends on the type of data written). Read-only for EFMT2 and EEFMT2.
- MEDIA10 - The IBM Enterprise Extended WORM Tape Cartridge (MEDIA10) physical media. The MEDIA10 capacity is the same as the MEDIA9 capacity.
- MEDIA11 - The IBM Enterprise Advanced Tape Cartridge (MEDIA11) physical media. MEDIA11 requires the EFMT4 or EEFMT4 recording format, and provides an uncompressed capacity of 4000 GB. Provides a compressed capacity of 12000 GB, assuming a 3:1 compression ratio (the compression ratio depends on the type of data written).
- MEDIA12 - The IBM Enterprise Advanced WORM Tape Cartridge (MEDIA12), physical media. The MEDIA12 capacity is the same as the MEDIA11 capacity.
- MEDIA13 - The IBM Enterprise Advanced Economy Tape Cartridge (MEDIA13) physical media. MEDIA13 requires the EFMT4 or EEFMT4 recording format, and

provides an uncompressed capacity of 500 GB. Provides a compressed capacity of 1500 GB, assuming a 3:1 compression ratio (the compression ratio depends on the type of data written). For this media type there is equivalent WORM cartridge.

You can use the TS1140 tape drive in the stand-alone environment or the tape library environment (automated or manual). Currently, the TS1140 tape drive does not have a cartridge loader.

Support for the TS1140 tape drive will be provided at z/OS V1R11 and later releases

**Note:**

1. If no recording technology has been specified for MEDIA9, MEDIA10, MEDIA11, MEDIA12, or MEDIA13, EFMT4 is the default recording technology. Other recording formats (EFMT3, EEFMT3, or EEFMT4) can be specified through data class. This applies to both the stand-alone and to the system-managed tape library environments. However, with the TS1140, EFMT3 and EEFMT3 are supported only with MEDIA9 and MEDIA10.
2. To enable the EFMT4 and EEFMT4 formatted cartridges (MEDIA9 and MEDIA10) to be relabelled/reused from load point on a 3592 Model E05 (3592-2 and 3592-2E) or on a 3592 Model E06 (3592-3E), drive microcode updates are required on these drives. This is particularly important in a system-managed tape library environment, because common scratch pools are used across the media types.
3. For an encrypted tape cartridge, the cartridge stores both the encrypted user data and the critical key management-related information needed to interact with the encryption key manager when decrypting data on the cartridge. A mix of data written in encrypted and non-encrypted formats is not supported on the same tape cartridge. Whether the data on a cartridge is written in encrypted format is determined during OPEN processing, when the first file sequence on the tape is written. If the first file written to a tape is in the encrypted format; all subsequent files written to that same tape cartridge will be written in the encrypted format. All files written to a cartridge in the encrypted format are encrypted using the same data key. The exception to this is the volume label structure for the first file sequence, which is encrypted using a key known to all encryption capable 3592 drives, which means it is effectively in the clear.
4. The TS1140 tape drive optionally provides performance scaling by using only 20 percent of the full capacity on a MEDIA9 or MEDIA11 cartridge. The default is to use the cartridge's full capacity. The performance scaling option is not available with the economy or WORM media type.
5. The TS1140 tape drive optionally provides performance segmentation. Performance segmentation divides the cartridge into a fast access segment and a slower access segment. The fast access segment will be filled first, after which the slower segment will be filled. This option is available on MEDIA9 and MEDIA11 tapes. The performance segmentation option is not available with the economy or WORM cartridge. The performance segmentation option is mutually exclusive with the performance scaling option.
6. The TS1140 tape drive emulates only 3590 Model B1x tape drives in the standalone and in the system-managed tape library environment (manual or automated).



7. The TS1140 tape drive is supported by the 3592 Model C06 tape controller (ESCON<sup>®</sup> or FICON<sup>®</sup> attachment) and with the C07 tape controller (FICON-only attachment). It is not supported with the older J70 tape controller.
8. The TS1140 (3592 Model E07) tape drive is not supported in the older 3494 automated tape library.
9. The TS1140 (3592 Model E07) tape drive coexists with 3592 Model J1A, 3592 Model E05 (3592-2 and 3592-2E), and 3592 Model E06 (3592-3E) devices in the 3584 automated tape library.
10. The TS1140 (3592 Model E07) tape drive coexists with 3490, 3490E, 3590, 3592 Model J1A, 3592 Model E05 (3592-2 and 3592-2E), and 3592 Model E06 (3592-3E) devices in a manual tape library.
11. The TS1140 tape drive cannot use the MEDIA3 or MEDIA4 cartridges used in 3590 tape drives, nor can it write to the older 3592 media types (MEDIA5, MEDIA6, MEDIA7, or MEDIA8).
12. For the system-managed tape library support (automated or manual), even though a mix of 3592 tape drives (different models) is supported under a single control unit, with z/OS system-managed tape library support, all devices under the same control unit must be homogenous and support the same capabilities. So, although a mix of 3592 tape drives is supported within the same library, within each control unit, all the devices must be either TS1140 tape drives (only) or TS1130 tape drives (only) or TS1120 tape drives (only). In addition to this, all TS1120 tape drives must also be homogeneous so a mix of encryption and non-encryption capable drives is also not supported within a control unit.

**Related reading:**

For additional information, see:

- IBM System Storage TS1140 Tape Drive InfoCenter (<http://publib.boulder.ibm.com/infocenter/3592drives/cust/index.jsp>)
- IBM System Storage 3592-C07 Controller Customer Information Center (<http://publib.boulder.ibm.com/infocenter/etc/cust/index.jsp>)
- *IBM System Storage 3592 Tape Drives and TS1120 Controller Introduction and Planning Guide*, GA32-0555,
- *IBM System Storage 3592 Tape Drives and TS1120 Controller Operator Guide*, GA32-0556

---

## Performance scaling and segmentation for TS1140

The TS1140 tape drive supports performance scaling and performance segmentation of media tape cartridges. These functions allow you to optimize performance for MEDIA9 and MEDIA11 cartridges; a cartridge can be defined for performance scaling or performance segmentation, but not both.

Except for the cartridge segment sizes for the EFMT4 and EEFMT4 recording formats, performance scaling and segmentation for the TS1140 is the same as for the TS1120. See “Performance scaling and segmentation for TS1120” on page 179 for an overview of performance scaling and segmentation and for information on the cartridge segment sizes for the EFMT2 and EEFMT2 recording formats.

Performance scaling for the TS1140 (3592 Model E07) tape drive limits the data written to the first 20% (the optimally scaled performance capacity) of the cartridge and when using the performance segmentation option, the overall capacity of the cartridge is limited to 86.6% of the total capacity. The fast access segment occupies

the first 20% of the cartridge, followed by the slower access segment. By default, the MEDIA9 or MEDIA11 cartridge is used to its full capacity. When written from loadpoint, a scaled or segmented tape cartridge is reformatted according to the assigned data class.

## z/OS software support for the TS1140 tape drive

Use z/OS software with the TS1140 tape drive to protect your data with the IBM System Storage family of tape media and the EFMT4 and EEFMT4 recording formats. Table 27 on page 180 describes the software support changes for the new TS1140 tape drive.

**Note:** The software support changes described in “z/OS software support for the encryption-capable TS1120 tape drive” on page 180 also apply to the TS1140.

*Table 2. Components that provide software support for the TS1140 tape drive*

Component	Function
DFSMSdfp AMS	AMS commands, CREATE LIBRARYENTRY, ALTER LIBRARYENTRY, CREATE VOLUMEENTRY, ALTER VOLUMEENTRY, DCOLLECT, and LISTCAT are changed to support the new EFMT4 and EEFMT4 recording technologies and the new MEDIA11, MEDIA12, and MEDIA13 media types. AMS allows the use of the new EFMT4 and EEFMT4 recording technologies and the use of the new MEDIA11, MEDIA12, and MEDIA13 media types as well as the printing and displaying of information about the recording technology and media type.
DFSMSdfp Device Services	Device Services manages the IBM System Storage Tape System devices.
DFSMSdfp ISMF	The ISMF Tape Library Application, Data Class Application, Mountable Tape Volume Application panels have been enhanced to support two new record formats (EFMT4 and EEFMT4) and three new media types (MEDIA11, MEDIA12 and MEDIA13).
DFSMSdfp NaviQuest	NaviQuest sample jobs and CLISTs have been updated to support the new recording formats (EFMT4 and EEFMT4) and the new media types (MEDIA11, MEDIA12 and MEDIA13).
DFSMSdfp OAM	OAM tape library support allows the use of the new recording formats (EFMT4 and EEFMT4) and the new media types (MEDIA11, MEDIA12 and MEDIA13) in the IBM 3584 Automated Tape library and in the manual tape library. OAM object tape support allows the use of TS1140 tape drives and media for object-related activity.
DFSMSdfp OCE/IFGOJES3	OCE/IFGOJES3 allows the use of the new EFMT4 and EEFMT4 recording technologies and use of the new MEDIA11, MEDIA12 and MEDIA13 media types.

Table 2. Components that provide software support for the TS1140 tape drive (continued)

Component	Function
DFSMSdfp SMS	SMS allows the use of the new EFMT4 and EEFMT4 recording technologies and use of the new MEDIA11, MEDIA12 and MEDIA13 media types. You can specify a data class to request data encryption (EEFMT4) or non-encryption (EFMT4) with media types MEDIA9 through MEDIA13. EFMT4 (non-encryption) is the default recording technology for the TS1140.
DFSMSdss	DFSMSdss ensures that encrypted data dumped to a TS1140 tape drive will not be doubly encrypted, unless the user makes specific arrangements for double-encryption.  DFSMSdss Stand Alone Restore will not read a dump data set that resides on an encrypted tape.
DFSMSHsm	DFSMSHsm allows the use of TS1140 tape drives and media for all DFSMSHsm tape related functions. The LIST TTOC SELECT parameters have been extended to take new values EFMT4 (or E4) and EEFMT4 (or EE4).
DFSMSrmm	These DFSMSrmm functions have been enhanced to support the TS1140: <ul style="list-style-type: none"> <li>• DFSMSrmm TSO subcommands now allow the use of the new EFMT4 and EEFMT4 recording technologies and the use of the new MEDIA11, MEDIA12 and MEDIA13 media types.</li> <li>• REXX variables of the TSO subcommand have been enhanced to support the TS1140</li> <li>• API structured field introducers have been enhanced to support the TS1140, including new compound SFI</li> </ul>
DFSORT	DFSORT works without change with the IBM System Storage Tape System devices.
EREP	EREP provides unique device type information for TS1140 tape drives when formatting LOGREC records.
z/OS Multiple Virtual Storage (MVS) Allocation	MVS Allocation allows the use of the new EFMT4 and EEFMT4 recording technologies and the use of the new MEDIA11, MEDIA12 and MEDIA13 media types when using the Dynamic Allocation Text Unit DALINCHG. MVS allocation (starting with z/OS V1R12) also allows a 2-byte specification for the DALINCHG parameter input.

## Using TS1140 tape drives in an IBM tape library environment

Before using the new TS1140 tape drive, ensure that all existing 3592 Model E05 and E06 drives in the library are upgraded to recognize and enable cartridges formatted for EFMT4 or EEFMT4 (MEDIA9 and MEDIA10) to be relabelled/reused

on the older E05 and E06 drives. Otherwise, job failures may occur with a drive with the incorrect microcode load being allocated.

Because the 3592 Model E07 is only downward read (and not write) compatible with the EFMT1 format (on MEDIA5 through MEDIA8), the EFMT2 and EEFMT2 formats (on MEDIA5 through MEDIA10), and the EFMT3 and EEFMT3 formats (on MEDIA5 through MEDIA8), you must specify the read-compatible special attribute indicator (in the tape configuration database) or use LABEL=(,,IN) on the DD statement of JCL to enable the 3592 Model E07 drive to be considered eligible for these combinations.

The considerations listed in “Using encryption-capable TS1120 tape drives in an IBM tape library environment” on page 182 also apply to the TS1140.

## Using TS1140 tape drives in a stand-alone environment

Before using the new TS1140 tape drive, ensure that all existing 3592 Model E05 and E06 drives are upgraded to recognize and enable cartridges formatted for EFMT4 or EEFMT4 (MEDIA9 and MEDIA10) to be relabelled/reused on the older E05 and E06 drives. Otherwise, job failures may occur with a drive with the incorrect microcode load being allocated.

The considerations listed in “Using encryption-capable TS1120 tape drives in a stand-alone environment” on page 183 also apply to the TS1140.

**Recommendation:** Use a manual tape library, DFSMSrmm, third-party tape management software, or write your own applications when using TS1140 tape drives in a stand-alone environment.

---

## Resolving recording technology conflicts for TS1140

3592 Model E05 (TS1120) devices, 3592 Model E06 (TS1130) devices, and 3592 Model E07 (TS1140) devices can all write to MEDIA9 and MEDIA10 media types. However, conflicts occur when an EFMT4 or EEFMT4 formatted cartridge is mounted on a 3592 Model E05 or 3592 Model E06 and is being relabelled or reused.

The OPEN and EOVS routines can resolve these recording technology conflicts if you meet these conditions:

- Set OPEN for output to the first file
- Specify VOLNSNS=YES in the DEVSUPxx member of PARMLIB
- Position the tape cartridge at the load point.

If these conditions are met and if the cartridge has an internal *volser* recorded in its volume control region, OPEN and EOVS routines rewrite the VOL1 label with the volume identifier in the sense data.

**Note:** To enable this support, make sure that the 3592 Model E05 and 3592 Model E06 devices are at the appropriate microcode level, so that an up-level (MEDIA9 and MEDIA10) volume can have its volume identifier returned in the sense data.

For additional information about resolving recording technology conflicts, see *z/OS DFSMS Using Magnetic Tapes* and *z/OS DFSMS Installation Exits*.

---

## Implementation considerations for using TS1140 tape drives

The implementation considerations listed in “Implementation considerations for using encryption-capable TS1120 tape drives” on page 184 also apply to the TS1140.

As appropriate, specify EE4 (EEFMT4 recording format) for encryption or use the media interchange recording technology specification (E3 for EFMT3 or EE3 for EEFMT3 with MEDIA9 and MEDIA10) to request that the lower recording formats be used. By default, when writing from load point, EFMT4 (E4) is used by the TS1140 tape drive (MEDIA9 through MEDIA13).

**Related reading:**

See Chapter 2, “Migration to the software support for TS1140 tape drives,” on page 15 for migration information and implementation information.



---

## Chapter 2. Migration to the software support for TS1140 tape drives

DFSMS software support for the TS1140 tape drive addresses media management and data allocation in an IBM 3584 Automated Tape Library and in the manual tape library (MTL). You can manage media and allocate data to appropriate non-library (stand-alone) drives through segregation of the real and emulating drives, third-party tape management software, or user-written applications. You can use the TS1140 tape drive on systems that are running z/OS V1R11 and above.

This topic outlines the tasks and associated procedures that must be performed to migrate to software support for the TS1140 tape drive tape drive in these environments:

- Stand-alone environment
- IBM tape library environment
- HSMplex
- OAMplex
- RMMplex

---

### Understanding coexistence considerations for TS1140

Coexistence support for the TS1140 tape drive is provided at z/OS V1R11 and above by installing the needed full-support PTFs without the Device Services enabling PTF.

In addition to this, existing device services support prevents the TS1140 tape drives from coming online on a system that does not have all of the full-support PTFs installed. Installation of the Devices Services enabling PTF brings in all of the needed full-support PTFs. See Table 3 on page 16 for a discussion of the coexistence PTFs that may be needed. For past discussion of the other 3592 models and their coexistence considerations, refer to “Understanding coexistence considerations for 3592 Model J1A” on page 347, “Understanding coexistence considerations for 3592 Model E05” on page 271, “Understanding coexistence considerations for encryption-capable TS1120” on page 187, and “Understanding coexistence considerations for TS1130” on page 99.

Review the coexistence migration tasks described in these topics:

Table 3. Coexistence migration tasks for TS1140 tape drives

Environment	Coexistence Considerations
Stand-Alone	<p>As described in Chapter 1, "Introduction for TS1140 tape drive," on page 3, z/OS DFSMS and related licensed programs provide full support for the TS1140 tape drive. EFMT4/EEFMT4 is supported with MEDIA9-MEDIA13 and EFMT3/EEFMT3 is also supported with MEDIA9-MEDIA10 (for read/write). Read-only support is provided for EFMT3/EEFMT3 (MEDIA5-MEDIA8), EFMT2/EEFMT2 (MEDIA5-MEDIA10) and EFMT1 (MEDIA5-MEDIA8). The TS1140 tape drive support enables the tape drives to operate in the stand-alone environment in 3590 Model B1x emulation and to coexist with other emulated tape drives. However, prior to using the new TS1140 tape drive, ensure that all existing 3592 Model E05 and E06 tape drives have their microcode upgraded to recognize and enable the EFMT4 and EEFMT4 formatted cartridges (MEDIA9 and MEDIA10) to be relabelled/reused on the 3592 Model E05 and Model E06. Also, ensure that VOLNSNS=YES is in the DEVSUPxx member of PARMLIB. Otherwise, job failures may occur with a drive with the incorrect microcode load being allocated.</p> <p>In the stand-alone (non-system managed environment), even though a mix (different models) of 3592 devices is supported under a control unit, IBM recommends that all 3592 devices under the same control unit be homogenous for easier separation and management.</p>
IBM Tape Library	<p>As described in Chapter 1, "Introduction for TS1140 tape drive," on page 3, z/OS DFSMS and related licensed programs provide full support for the TS1140 tape drive. EFMT4/EEFMT4 is supported with MEDIA9-MEDIA13 and EFMT3/EEFMT3 is also supported with MEDIA9-MEDIA10 (for read/write). Read-only support is provided for EFMT3/EEFMT3 (MEDIA5-MEDIA8), EFMT2/EEFMT2 (MEDIA5-MEDIA10) and EFMT1 (MEDIA5-MEDIA8). The system-managed tape library support allows the tape drives to operate in an ATL or MTL environment as 3590 Model B1x devices, providing device allocation and tape media management support. As appropriate for the library type and model, this support allows the TS1140 tape drive to coexist with other emulated 3590-1 tape drives in the same tape library. However, prior to using the new TS1140 tape drive, ensure that all existing 3592 Model E05 and Model E06 tape drives have their microcode upgraded to recognize and enable the EFMT4 and EEFMT4 formatted cartridges (MEDIA9 and MEDIA10) to be relabelled/reused on the 3592 Model E05 and E06. Also, ensure that VOLNSNS=YES is in the DEVSUPxx member of PARMLIB. Otherwise, job failures may occur with a drive with the incorrect microcode load being allocated.</p> <p>In addition to this, in the system-managed tape library environment, all 3592 drives under the same control unit must have the same recording format capabilities and report under the same ERDS physical identifier (EPI). This ensures that all of the devices under the same control unit are homogeneous and that each device under the same control unit is capable of handling the request.</p> <p>A tape configuration database (TCDB) with EFMT4 and EEFMT4 volume records can coexist with lower-level systems. No additional coexistence support is needed to support the new recording formats and the new media types. However, because the 3592 Model E07 is only downward read (and not write) compatible with the EFMT3 and EEFMT3 formats (on MEDIA5-MEDIA8), EFMT2 and EEFMT2 formats (on MEDIA5-MEDIA10), and EFMT1 format (on MEDIA5-MEDIA8), you must specify (as appropriate) the read-compatible special attribute indicator (in the tape configuration database) or use LABEL=(,,IN) on the DD statement of JCL to enable the 3592 Model E07 drive to be considered eligible for recording technology and media type combinations discussed above.</p>



Table 3. Coexistence migration tasks for TS1140 tape drives (continued)

Environment	Coexistence Considerations
DFSMSdfp Device Services/AOM	<p>The Device Services component prevents any device that has an unknown EPI from coming online. Therefore, if a TS1140 tape drive is attached to a system that does not have any of the TS1140 support installed, the device is not allowed on-line and the following existing message text is issued for message IEA435I:</p> <p>'UNKNOWN DEVICE IN EMULATION MODE NOT BROUGHT ONLINE'</p> <p>When the Device Services full function support APAR is installed without the enabling APAR, the Device Service Exit will recognize the device EPI, but because the enabling APAR that brings all of the software support in is not installed, the device will not come on-line and the following new message text will be issued for IEA435I:</p> <p>'3592-4E DRIVE DETECTED BUT NOT ALL 3592-4E SUPPORT IS PRESENT'.</p>
HSMplex	<p>In an HSMplex, all systems in the HSMplex should have full support for the 3592-4E tape subsystem before any instance of DFSMSHsm uses the new tape drives. If any system does not fully support the 3592-4E, a request for tape input can fail because a 3592-4E device is not available on that system.</p>
OAMplex	<p>For OAM's object support customers, in addition to the planning steps required for migration to the software support for the TS1140 tape drives in the stand-alone and IBM tape library environments, there are coexistence considerations your installation must take into account before you install the software in an OAMplex:</p> <ul style="list-style-type: none"> <li>• For the TS1140 tape drive support, OAM object tape coexistence support is provided at z/OS V1R11 and above, through installation of the full support PTF without the device services enabling PTF.</li> <li>• OAM coexistence support prevents lower-level systems from selecting volumes with ERDS Physical Identifier (EPI) values for object write requests that are not supported on that system.</li> <li>• OAM object support has coexistence considerations when running in an OAMplex environment with at least one system with the full support installed and enabled and at least one system without the full support for the new devices installed and enabled. In this mixed support environment, it is possible for a retrieve request to be received for an object that resides on a tape cartridge volume written in the EFMT4 and EEFMT4 format by a system that does not have the TS1140 tape drive full support installed. Coexistence support is provided that allows OAM to attempt to locate an instance of OAM in the OAMplex where the full support is installed and enabled. If an instance of OAM is found where the request can be processed, the OAM on the system where the request originated will ship the retrieve request, if the object is not greater than 50 MB, to the target system using XCF messaging services.</li> <li>• Once TS1140 tape drives devices are used in an OAMplex environment and objects are written to tape volumes with the new EPI value recorded, it is expected that any OAM on a system where the full support is installed and enabled is eligible for processing requests using that volume. Therefore, TS1140 tape drives devices must be available to all instances of OAM where the full support is installed.</li> </ul>
OCE (Open / Close / End-of-Volume)	None.
RMMplex	None.

---

## Preparing to install the software

### Related reading:

For additional information, see:

- IBM System Storage TS1140 Tape Drive InfoCenter (<http://publib.boulder.ibm.com/infocenter/3592drives/cust/index.jsp>)
- IBM System Storage 3592-C07 Controller Customer Information Center (<http://publib.boulder.ibm.com/infocenter/etc/cust/index.jsp>)
- *IBM System Storage 3592 Tape Drives and TS1120 Controller Introduction and Planning Guide*, GA32-0555,
- *IBM System Storage 3592 Tape Drives and TS1120 Controller Operator Guide*, GA32-0556

For encryption key manager requirements, refer to the InfoCenters for TKLM or IBM Security Key Lifecycle Manager.

Coexistence support for the TS1140 tape drive is provided with z/OS V1R11 and above by installing the appropriate full support PTFs without the device services enabling PTF.

---

## Installing the appropriate PTFs

Refer to the 3592 PSP bucket for the APAR and PTF numbers applicable for each release. An enabling PTF exists to provide full device support for the TS1140 tape drive. Installation of the appropriate enabling PTF pulls in all of the needed support PTFs and indicates to the system that all of the needed software support is installed. For z/OS V1R11 and above, refer to enabling APAR OA33947. Also for the added TS1140 legacy read support for MEDIA5, MEDIA6, MEDIA7, and MEDIA8 refer to OA37269. This is needed in addition to the base TS1140 support and requires that the TS1140 tape drives be at PGA1 code level D3I3\_5CD (or higher).

In addition, as appropriate for your environment and release level, determine what coexistence PTFs are needed for your environment.

---

## Planning for DFSMS software support for the TS1140 tape drive

The planning steps you must consider to successfully install the TS1140 tape drive software, vary depending upon the tape environment you have installed. Table 4 on page 19 discusses planning considerations for stand-alone environments (including tape devices installed in vendors' automated tape libraries) and for IBM tape library environments.

Table 4. TS1140 tape drive planning considerations

Area	Planning Considerations
System customization: stand-alone environment	<ol style="list-style-type: none"> <li>1. Determine which data needs to be encrypted and set up the appropriate data class policy specifying EEFMT4 (or EEFMT3 for media interchanges). Also specify, as appropriate, the non-encryption recording formats, EFMT4 (or EFMT3 for media interchanges). If a TS1140 tape drive tape drive is allocated, the default recording format is EFMT4. EFMT4 and EEFMT4 can be used with MEDIA9 through MEDIA13 and MEDIA9 and MEDIA10 can be used with EFMT3 and EEFMT3. Also, modify or create ACS routines to associate the tape output functions with a data class that has the appropriate recording format specified.</li> <li>2. As appropriate, determine which key labels are to be used and how they will be specified, data class, the DD statement or encryption key manager established defaults.</li> <li>3. Determine whether you will need help from your tape management system vendor and contact them, if needed.</li> <li>4. As appropriate, plan for the installation of the encryption key manager (IBM Security Key Lifecycle Manager or TKLM) and decide which of the supported key stores to use.</li> <li>5. As appropriate, plan for the key labels that will be used and the encoding mechanism (label or hash) for each and where the key labels will be specified.</li> <li>6. For in-band key management (with encryption), update the IOS PARMLIB member (IECIOSxx) using the EKM command. Also create a z/OS UNIX segment for the IOS address space.</li> <li>7. Upgrade 3592 Models E05 and E06 drive microcode to enable the drives to recognize and enable the EFMT4 and EEFMT4 formatted cartridges to be relabelled/reused. Also, ensure that VOLNSNS=YES is in the DEVSUPxx member of PARMLIB.</li> <li>8. Determine which systems should have coexistence support and which systems should have full support.</li> <li>9. Determine when to IPL the host machine after installing the coexistence PTFs, if needed.</li> <li>10. Determine when to IPL the host machine after installing all necessary PTFs.</li> </ol>

Table 4. TS1140 tape drive planning considerations (continued)

Area	Planning Considerations
System customization: IBM library tape environment	<ol style="list-style-type: none"> <li>1. Determine which data needs to be encrypted and set up the appropriate data class policy specifying EEFMT4 (or EEFMT3 for media interchanges). Also specify, as appropriate, the non-encryption recording formats, EFMT4 (or EFMT3 for media interchanges). If a TS1140 tape drive is allocated, the default recording format is EFMT4. EFMT4 and EEFMT4 can be used with MEDIA9 through MEDIA13 and MEDIA9 and MEDIA10 can be used with EFMT3 and EEFMT3. Also, modify or create ACS routines to associate the tape output functions with a data class that has the appropriate recording format specified.</li> <li>2. Because the TS1140 is only downward read (and not write) compatible with the EFMT1 format (on MEDIA5 through MEDIA8), the EFMT2 and EEFMT2 formats (on MEDIA5 through MEDIA10), and the EFMT3 and EEFMT3 formats (on MEDIA5 through MEDIA8), explicit specification of the read-compatible special attribute indicator (in the tape configuration database) or usage of the LABEL=(,,IN) on the DD statement of JCL is needed to enable the TS1140 tape drive to be considered eligible for these volume types.</li> <li>3. As appropriate, determine which key labels are to be used and how they will be specified, data class, the DD statement or encryption key manager established defaults.</li> <li>4. Determine whether you will need help from your tape management system vendor and contact them, if needed.</li> <li>5. As appropriate, plan for the installation of the encryption key manager (IBM Security Key Lifecycle Manager or TKLM) and decide which of the supported key stores to use.</li> <li>6. As appropriate, plan for the key labels that will be used and the encoding mechanism (label or hash) for each and where the key labels will be specified.</li> <li>7. For in-band key management (with encryption), update the IOS PARMLIB member (IECIOSxx) using the new EKM command. Also create a z/OS UNIX segment for the IOS address space.</li> <li>8. Upgrade 3592 Models E05 and E06 drive microcode to enable the drives to recognize and enable the EFMT4 and EEFMT4 formatted cartridges to be relabelled/reused. Also, ensure that VOLNSNS=YES is in the DEVSUPxx member of PARMLIB.</li> <li>9. Identify the installation exit changes that are needed.</li> <li>10. Determine which systems should have coexistence support and which systems should have full support.</li> <li>11. Determine when to IPL the host machine after installing the coexistence PTFs, if needed.</li> <li>12. Determine when to IPL the host machine after installing all necessary PTFs.</li> </ol>

Table 4. TS1140 tape drive planning considerations (continued)

Area	Planning Considerations
System customization: OAM object tape environment	<p>The planning steps that you must consider in tape environments that use OAM objects vary depending upon the type of environment that is installed.</p> <ol style="list-style-type: none"> <li>1. If you install the TS1140 tape drive devices in a stand-alone environment:               <ol style="list-style-type: none"> <li>a. Follow the system customization planning steps listed for a stand-alone environment.</li> <li>b. Determine the esoteric or generic device names that need to be added to STORAGEEGROUP statements in the CBROAMxx member of PARMLIB for the object storage groups that are to use the new devices.</li> <li>c. Determine whether to use the global keyword DSNWITHSGNAME on the SETOAM statement in the CBROAMxx member of PARMLIB to append the object storage group name to the OAM object tape data set names. See “Object tape data set low-level qualifier enhancement” on page 413 for additional information.</li> <li>d. Determine the new data classes that need to be defined in STORAGEEGROUP statements in the CBROAMxx member of PARMLIB for the object storage groups that are to use the new encryption format EEFMT4 (by default, the non-encryption recording format EFMT4 is used).</li> </ol> </li> <li>2. If you install the TS1140 tape drive devices in an IBM tape library:               <ol style="list-style-type: none"> <li>a. Follow the system customization planning considerations listed for an IBM tape library environment.</li> <li>b. Determine the new data classes that need to be defined in STORAGEEGROUP statements in the CBROAMxx member of PARMLIB for the object storage groups that are to use the new devices and the new encryption format EEFMT4.</li> </ol> </li> <li>3. In addition, if you install the TS1140 tape drive devices in an OAMplex:               <ol style="list-style-type: none"> <li>a. Ensure that the TS1140 tape drive devices are available to all instances of OAM where the full support software is installed.</li> <li>b. Determine whether systems exist that will require coexistence support. This situation is particularly important in an OAMplex where at least one system has the full-support software installed and enabled, and at least one system will not have all of the support installed or enabled. Coexistence support is needed if not all of the systems in the OAMplex will be at the same full-support level.</li> <li>c. To provide this coexistence support, as appropriate for the support and the release level, install the OAM full-support PTF without the enabling PTF or any separate coexistence support PTF.</li> <li>d. Determine when to IPL the host machine after installing the coexistence PTFs, if needed.</li> </ol> </li> </ol>
System customization: DFSMSHsm	See “Implementation considerations for using TS1140 tape drives” on page 13 and “DFSMSHsm tips” on page 233.

Table 4. TS1140 tape drive planning considerations (continued)

Area	Planning Considerations
Storage administration: stand-alone tape environment	<ol style="list-style-type: none"> <li>1. Determine how to setup your tape management systems pooling support to segregate rewritable (MEDIA9, MEDIA11, and MEDIA13) and WORM (MEDIA10 and MEDIA12) media and also to segregate the extended, advanced, and economy length cartridges, as appropriate, for your job and application usage. The older 3592 media types (MEDIA5 through MEDIA8) are supported on the TS1140 only for read requests.</li> <li>2. Review the usage of the DEVSUP<sub>xx</sub> PARMLIB option, ENFORCE_DC_MEDIA, (optional) to ensure that the media type mounted is the media type requested through data class. This can be used in conjunction with the tape management systems pooling support as an additional safety check.</li> <li>3. Review the existing SMS data class media policies to ensure compatibility with existing tape scratch pool policies before enabling the DEVSUP<sub>xx</sub> PARMLIB option, ENFORCE_DC_MEDIA.</li> <li>4. Review the existing SMS data class recording technology policies to ensure that data class policies set to EFMT3 and EEFMT3 are being appropriately used. If a TS1140 tape drive is allocated and the specified data class indicates EFMT3 or EEFMT3, the drive will record in the lower recording technology. Also, remember that the TS1140 can only write to MEDIA9 and MEDIA10 (EFMT3, EEFMT3, EFMT4, and EEFMT4) and MEDIA11, MEDIA12, and MEDIA13 (EFMT4 and EEFMT4), so also review any existing SMS data classes for applicability.</li> <li>5. Determine the data class updates that are needed to request the appropriate recording format for the TS1140 tape drives. If a TS1140 tape drive is allocated, the default recording format is EFMT4 (non-encryption).</li> <li>6. Determine if media should use performance segmentation, with a fast access segment to be filled first, and a slower access segment to be filled after. If you decide to use the performance segmentation attribute (available only with MEDIA9 and MEDIA11 tape cartridges, and mutually exclusive with performance scaling), you can: <ol style="list-style-type: none"> <li>a. Define a data class that requests performance segmentation.</li> <li>b. Modify or create ACS routines to associate the tape output functions using performance segmentation with a data class that requests performance segmentation.</li> </ol> </li> <li>7. Determine if media should be used at full capacity or scaled for optimal performance. If you decide to use the performance scaling attribute (available only with MEDIA9 and MEDIA11 tape cartridges), you can: <ol style="list-style-type: none"> <li>a. Define a data class that requests performance scaling.</li> <li>b. Modify or create ACS routines to associate the tape output functions using performance scaling with a data class that requests performance scaling.</li> </ol> </li> <li>8. Determine how to allocate media to appropriate nonlibrary drives. Consider using the IBM manual tape library. You can also segregate the real drives from the emulating drives, use third-party tape management software, or use customer-written applications.</li> <li>9. Identify any needed changes to the hardware configuration definition (HCD) to define the new devices.</li> </ol>

Table 4. TS1140 tape drive planning considerations (continued)

Area	Planning Considerations
Storage administration: IBM tape library environment	<ol style="list-style-type: none"> <li>1. Review the usage of the DEVSUPxx PARMLIB option, MTL_NO_DC_WORM_OK, if the WORM cartridges in the manual tape library environment will be mounted through use of the tape management systems pooling support versus a data class WORM media specification.</li> <li>2. Determine the 3592 media usage of rewritable (MEDIA9, MEDIA11, and MEDIA13) and WORM (MEDIA10 and MEDIA12) media and also the usage of the extended, advanced and economy length cartridges. Then make the appropriate data class definition updates to select the appropriate media type. WORM media can only be used if explicitly requested through data class.</li> <li>3. Review ACS routines for changes needed in selecting tape storage groups and libraries that have the TS1140 tape drive devices.</li> <li>4. Determine the data class updates that are needed to use the recording technology, media type, and performance scaling or performance segmentation data class attribute (performance scaling or segmentation available only with MEDIA9 and MEDIA11 tape cartridges).</li> <li>5. Identify any needed changes to the HCD to define the new devices.</li> <li>6. To define the partitioning category code for MEDIA9, MEDIA10, MEDIA11, MEDIA12 and MEDIA13 tape cartridges, specify the appropriate parameter of the DEVSUPxx parmlib member.</li> <li>7. Because the TS1140 is only downward read (and not write) compatible with the EFMT1 format (on MEDIA5 through MEDIA8), the EFMT2 and EEFMT2 formats (on MEDIA5 through MEDIA10), and the EFMT3 and EEFMT3 formats (on MEDIA5 through MEDIA8), explicit specification of the read-compatible special attribute indicator (in the tape configuration database) or usage of the LABEL=(,,,IN) on the DD statement of JCL is needed to enable the TS1140 tape drive to be considered eligible for the combinations above.</li> </ol>
Storage administration: OAM object tape environment	<p>The planning steps that you must consider in tape environments that use OAM objects vary depending upon the type of environment that is installed.</p> <ol style="list-style-type: none"> <li>1. If you install the TS1140 tape drive devices in a stand-alone environment, follow the storage administration planning steps listed for a stand-alone environment.</li> <li>2. If you install the TS1140 tape drive devices in an IBM tape library: <ol style="list-style-type: none"> <li>a. Follow the storage administration planning steps listed for an IBM tape library environment.</li> <li>b. Review ACS routines for STORE or CTRANS environments and make any changes needed to ensure proper class assignment.</li> </ol> </li> <li>3. If you install the TS1140 tape drive devices in an OAMplex, you must make the devices available to all instances of OAM where the full support is installed.</li> </ol>

Implementing this change could affect these areas of your processing environment:

Area	Considerations
Storage Administration	<p>The following NaviQuest CLISTs have changed:</p> <ul style="list-style-type: none"> <li>• ACJBAD1 - Sample job for data class define/alter/display</li> <li>• ACJBAL1 – Sample job for tape library define/alter/display</li> <li>• ACJBAL5 – Sample job for tape library report</li> <li>• ACJBAL6 – Sample job to generate tape library list and report</li> <li>• ACQBAC2 – Generates SMS report</li> <li>• ACQBAD1 – CLIST for define/alter/display of data class</li> <li>• ACQBAD2 – CLIST for define/alter a data class</li> <li>• ACQBAL1 – CLIST for define/alter/ display of tape library</li> <li>• ACQBAL2 – CLIST for define/alter tape library</li> <li>• ACQBAL3 – CLIST for display of tape library</li> <li>• ACQBAL5 – CLIST for report from a saved tape library list</li> <li>• ACQBAL6 – CLIST for generating a tape library list</li> <li>• ACBQFLR2 - ONLINE- SMS config report from DCOLLECT</li> <li>• ACBQUTR3 – Adds legend to reports for headings DS, DASD volume &amp; TAPE volume reports from saved table/DCOLLECT</li> <li>• ACBHELP - CLIST for NaviQuest help</li> </ul> <p>ISMF panels have been changed to support the two new recording formats, EFMT4 and EEFMT4 and the three new media types MEDIA11, MEDIA12 and MEDIA13. See Chapter 5, “ISMF modifications for TS1140 tape drive,” on page 45 for information about ISMF support for the TS1140 tape drive.</p>
Operations	<p>These commands have been updated with this support:</p> <ul style="list-style-type: none"> <li>• DEVSERV QLIB,CATS</li> <li>• DEVSERV QTAPE</li> <li>• DISPLAY SMS,VOLUME</li> <li>• IDCAMS ALTER LIBRARYENTRY</li> <li>• IDCAMS ALTER VOLUMEENTRY</li> <li>• IDCAMS CREATE LIBRARYENTRY</li> <li>• IDCAMS CREATE VOLUMEENTRY</li> <li>• IDCAMS DCOLLECT</li> <li>• IDCAMS LISTCAT</li> <li>• LIBRARY DISPDRV</li> <li>• LIBRARY ENTER</li> <li>• LIBRARY SETCL</li> </ul>
Auditing	None.



Area	Considerations
Application development	<p>The mapping macros and installation exits listed have been changed for this function.</p> <ul style="list-style-type: none"> <li>• CBRTDSI - Maps the Tape Device Selection Information</li> <li>• CBRTVI - Maps the Tape Volume Information</li> <li>• CBRUXCPL - Installation Exit CBRUXCUA Parameter List</li> <li>• CBRUXEPL - Installation Exit CBRUXENT Parameter List</li> <li>• CBRUXJPL - Installation Exit CBRUXEJC Parameter List</li> <li>• CBRUXNPL - Installation Exit CBRUXVNL Parameter List</li> <li>• DALINCHG - Dynamic Allocation DALINCHG Text Unit</li> <li>• EDGRDEXT - DFSMSrmm Data Set Extract record</li> <li>• EDGRVEXT - DFSMSrmm Volume Extract Record</li> <li>• EDGRXEXT - DFSMSrmm Extended Extract record</li> <li>• EDGXSFI - DFSMSrmm API SFI definitions</li> <li>• IECUCBCX - Maps the Tape UCB Device Class extension</li> <li>• IFGTEP - Maps the installation exit main parameter list</li> <li>• IEZDEB - Maps the data extent block (DEB)</li> <li>• IHADFVT - Maps the data facilities vector table</li> </ul> <p><b>Tracking Data Written:</b> An application may track in KBs, data such as the number of logical bytes written, the number of physical bytes written, the amount of free space remaining on a volume, the capacity of the volume, or the number of logical bytes deleted. With a 1+ TB tape (non-compressed), the possibility exists with the TS1140 (as well as the TS1130) to overflow some of the 4-byte fields that contain these values. Of particular concern would be the logical data-related fields that (with compression) deal with an amount of data that may be larger than the physical capacity of the tape. Applications that use, store, and display this type of information may need to account for and determine how best to handle an overflow situation. For a signed (4-byte) integer X'7F FF FF FF' (2,147,483,647 in KBs) supports 2+ TBs and for an unsigned (4-byte) integer X'FF FF FF FF' (4294967295 in KBs) supports 4+ TBs.</p>
Diagnostic procedures	<p>The messages listed have been changed for this support.</p> <ul style="list-style-type: none"> <li>• CBR0113I</li> <li>• CBR0114I</li> <li>• CBR0119I</li> <li>• CBR1082I</li> <li>• CBR1083I</li> <li>• CBR1084I</li> <li>• CBR1085I</li> <li>• CBR1180I</li> <li>• CBR1220I</li> <li>• CBR1240I</li> <li>• CBR3015I</li> <li>• CBR3660A</li> <li>• CBR3781I</li> <li>• CBR4105I</li> <li>• CBR6419I</li> <li>• IEA435I</li> <li>• IEH623E</li> <li>• IEH641I</li> <li>• IGF513I</li> </ul>
Automation products	None.
General use	<p>For DFSMSrmm, use the RMM subcommands ADDVOLUME, CHANGEVOLUME, and SEARCHVOLUME to specify the new media types (MEDIA11, MEDIA12, and MEDIA13), the recording technology EFMT4 or EEFMT4, and for EEFMT4, the key labels KEYLABEL1/KEYENCODE1 and KEYLABEL2/KEYENCODE2.</p>

---

## Implementing the DFSMS software support for the TS1140 tape drive

To implement the TS1140 tape drives software support, perform the system-level and application-level tasks listed in the following tables. **Required** tasks apply to any DFSMS installation enabling the function. **Optional** tasks apply to only specified operating environments or to situations where there is more than one way to set up or enable the function. For more details on the procedures associated with a given task, see the reference listed.

System-level tasks	Condition	Procedure reference
<i>Stand-alone tape environment</i>	Required	
<ol style="list-style-type: none"><li>1. Implement the data class policy specifying EFMT4 or EEFMT4. Also, specify as appropriate, the interchange recording formats, EFMT3 or EEFMT3. Also, modify or create ACS routines to associate the tape output functions with a data class that has the appropriate recording format specified. If no data class is used, EFMT4 will be the recording technology.</li><li>2. As appropriate, install the encryption key manager (IBM Security Key Lifecycle Manager or TKLM) and set up the key store it will use.</li><li>3. As appropriate, create the data classes or the DD statements (or use encryption key manager defaults) to specify the key labels and their encoding mechanism (label or hash).</li><li>4. As appropriate, for in-band key management, update the IOS PARMLIB member (IECIOSxx) using the new EKM command. Also create a z/OS UNIX segment for the IOS address space.</li><li>5. Upgrade 3592 Model E05 and 3592 Model E06 microcode to enable the drives to recognize and enable the EFMT4 or EEFMT4 formatted cartridges to be relabelled/reused. Also, ensure that VOLNSNS=YES is in the DEVSUPxx member of PARMLIB.</li><li>6. Make the required installation exit changes.</li><li>7. Make any needed changes to the HCD to define the new devices.</li><li>8. If more than one recording technology is used for the same device type, create a unique esoteric for each of the recording technologies. Use the esoteric unit names in DFSMSHsm to direct allocations uniquely to each group of devices.</li><li>9. If performance scaling or performance segmentation is used (available only with MEDIA9 and MEDIA11 tape cartridges), update or create ACS routines to assign a data class to tape output functions. For example, for DFSMSHsm, you can filter on single file tape data set names used by DFSMSHsm functions. Define the data class with the performance scaling or performance segmentation attribute.</li><li>10. Add new device esoteric unit names or generic unit names to STORAGEGROUP statements in the CBROAMxx member of PARMLIB for the object storage groups that are to use the new devices. The esoteric or generic unit name must consist of TS1140 tape drives exclusively because the EFMT4 and EEFMT4 recording technologies are not compatible with other devices.</li><li>11. Install coexistence PTFs as appropriate.</li><li>12. IPL the system.</li></ol>	<ul style="list-style-type: none"><li>• <i>z/OS DFSMS OAM Planning, Installation, and Storage Administration Guide for Object Support</i></li><li>• <i>z/OS HCD User's Guide</i></li><li>• <i>z/OS DFSMSHsm Implementation and Customization Guide</i></li></ul>	

---

System-level tasks	Condition	Procedure reference
<p><i>IBM tape library environment</i></p> <ol style="list-style-type: none"> <li>1. Implement the data class policy specifying EFMT4 or EEFMT4. Also, specify as appropriate, EFMT3 or EEFMT3 (for media interchange). Also, modify or create ACS routines to associate the tape output functions with a data class that has the appropriate recording format specified.</li> <li>2. Because the TS1140 is only downward read (and not write) compatible with MEDIA9 and MEDIA10 (EFMT2 and EEFMT2) and MEDIA5 through MEDIA8 (EFMT1, EFMT2, EEFMT2, EFMT3 and EEFMT3), explicit specification of the read-compatible special attribute indicator (in the tape configuration database) or usage of the LABEL=(,IN) on the DD statement of JCL is needed to enable the TS1140 tape drive to be considered eligible for these volume types.</li> <li>3. As appropriate, install the encryption key manager (IBM Security Key Lifecycle Manager or TKLM) and set up the key store it will use.</li> <li>4. As appropriate, create the data classes or the DD statements (or use encryption key manager defaults) to specify the key labels and their encoding mechanism (label or hash).</li> <li>5. For in-band key management, update (as appropriate) the IOS PARMLIB member (IECIOSxx) using the EKM command. Also create a z/OS UNIX segment for the IOS address space.</li> <li>6. Upgrade 3592 Model E05 and 3592 Model E06 microcode to enable the library drives to recognize and enable the EFMT4 or EEFMT4 formatted cartridges to be relabelled/reused. Also, ensure that VOLNSNS=YES is in the DEVSUPxx member of PARMLIB.</li> <li>7. Make the required installation exit changes.</li> <li>8. Define or alter existing data class constructs as appropriate, to specify the EFMT4 or EEFMT4 recording technology, MEDIA9, MEDIA10, MEDIA11, MEDIA12, or MEDIA13 media type, and the performance attributes (performance scaling or performance segmentation available only with MEDIA9, or MEDIA11 tape cartridges).</li> <li>9. Define or alter existing storage group constructs to include libraries with the new TS1140 tape drives devices.</li> <li>10. Update ACS routines to direct allocation to the TS1140 tape drives device as requested.</li> <li>11. Validate and activate any new or modified SMS configuration.</li> <li>12. Make any needed changes to the HCD to define the new devices.</li> <li>13. To define the partitioning category code for MEDIA9, MEDIA10, MEDIA11, MEDIA12, or MEDIA13 tape cartridges, specify the appropriate parameter of the DEVSUPxx parmlib member.</li> <li>14. IPL the system.</li> </ol>	Required	<ul style="list-style-type: none"> <li>• <i>z/OS DFSMS OAM Planning, Installation, and Storage Administration Guide for Tape Libraries</i></li> <li>• <i>z/OS HCD User's Guide</i></li> <li>• <i>z/OS DFSMSdfp Storage Administration</i></li> </ul>

System-level tasks	Condition	Procedure reference
<p data-bbox="157 216 423 241"><i>OAM object tape environment</i></p> <p data-bbox="157 268 792 342">The migration steps that you must take in tape environments that use OAM objects vary depending upon the type of environment that is installed:</p> <ol data-bbox="157 352 792 1535" style="list-style-type: none"> <li data-bbox="157 352 792 636">1. If you install the new TS1140 tape drives devices in an OAMplex: <ol data-bbox="191 415 792 636" style="list-style-type: none"> <li data-bbox="191 415 792 489">a. Make the new TS1140 tape drives devices available to all instances of OAM where the full support software is installed.</li> <li data-bbox="191 499 792 525">b. Install coexistence PTFs as appropriate.</li> <li data-bbox="191 535 792 636">c. Consider setting DSNWITHSGNAME in the SETOAM statement in the CBROAMxx PARMLIB member. Review your ACS routines if appending the storage group name to OAM data set names (DSNWITHSGNAME).</li> </ol> </li> <li data-bbox="157 646 792 909">2. If you install the new TS1140 tape drives devices in an IBM tape library: <ol data-bbox="191 709 792 909" style="list-style-type: none"> <li data-bbox="191 709 792 762">a. Follow the migration steps listed for an IBM tape library environment.</li> <li data-bbox="191 772 792 846">b. Define the new data classes in STORAGEEGROUP statements in the CBROAMxx member of PARMLIB for the object storage groups that are to use the new devices.</li> <li data-bbox="191 856 792 909">c. Make the needed changes to ACS routines for ALLOC, STORE, or CTRANS environments.</li> </ol> </li> <li data-bbox="157 919 792 1535">3. If you install the new TS1140 tape drives devices in a stand-alone environment: <ol data-bbox="191 982 792 1535" style="list-style-type: none"> <li data-bbox="191 982 792 1035">a. Follow the migration steps listed for a stand-alone environment.</li> <li data-bbox="191 1045 792 1245">b. Add new device esoteric unit names or generic unit names to STORAGEEGROUP statements in the CBROAMxx member of PARMLIB for the object storage groups that are to use the new EFMT4 or EEFMT4 recording technologies. The esoteric or generic unit name must consist of TS1140 tape drives exclusively because the EFMT4 and EEFMT4 recording technologies are not compatible with the other 3592 drives.</li> <li data-bbox="191 1255 792 1350">c. Consider setting DSNWITHSGNAME in the SETOAM statement in the CBROAMxx PARMLIB member. Review your ACS routines if appending the storage group name to OAM data set names (DSNWITHSGNAME).</li> <li data-bbox="191 1360 792 1413">d. Make the needed changes to ACS routines for ALLOC, STORE and CTRANS environments.</li> <li data-bbox="191 1423 792 1535">e. Define the new data classes in STORAGEEGROUP statements in the CBROAMxx member of PARMLIB for the object storage groups that are to use the new EFMT4 or EEFMT4 recording technologies.</li> </ol> </li> </ol>	Required	<p data-bbox="1036 216 1425 300"><i>z/OS DFSMS OAM Planning, Installation, and Storage Administration Guide for Object Support</i></p>
<p data-bbox="157 1549 423 1575"><i>DFSMSHsm tape environment</i></p> <p data-bbox="157 1602 792 1707">DFSMSHsm allows the specification of tape unit names using either generic or esoteric names. Installations that have a mixture of non-SMS-managed 3590 devices defined under the 3590-1 generic name, need to perform these steps:</p> <ol data-bbox="157 1717 792 1879" style="list-style-type: none"> <li data-bbox="157 1717 792 1743">1. Define a unique esoteric for each recording technology.</li> <li data-bbox="157 1753 792 1879">2. Use the SETSYS USERUNITTABLE command to define these esoteric names to DFSMSHsm. This also applies to mixed devices in the 3490 generic. Installations that use SMS-managed tape devices or have a single 3590-1 recording technology, do not need to define an esoteric for those devices.</li> </ol>	Required	<ul data-bbox="1036 1560 1425 1665" style="list-style-type: none"> <li data-bbox="1036 1560 1425 1612">• <i>z/OS DFSMSHsm Implementation and Customization Guide</i></li> <li data-bbox="1036 1623 1425 1665">• <i>z/OS DFSMSHsm Storage Administration</i></li> </ul>

<b>System-level tasks</b>	<b>Condition</b>	<b>Procedure reference</b>
<p><i>Setting up DFSMShsm to use WORM output tapes for ABACKUP</i></p> <p>In a SMS tape environment, and optionally in a non-SMS tape environment, the SMS data class construct can be used to select WORM tapes for ABACKUP processing. The output data set prefix specified in the aggregate group definition can be used by the ACS routines to select a WORM data class. Set up the ACS routine and the output data set name to uniquely identify the ABARS output files that must go to WORM tape.</p> <p>In a non-SMS tape environment, the default allows tape pooling to determine if ABARS data sets go to WORM or R/W media. Optionally, if the DEVSUPxx parameter, ENFORCE_DC_MEDIA=ALLMEDIATY or ENFORCE_DC_MEDIA=MEDIA5PLUS, is used, then the data class must request the appropriate media type for it to be successfully mounted.</p>	Required	<ul style="list-style-type: none"> <li>• <i>z/OS DFSMShsm Implementation and Customization Guide</i></li> <li>• <i>z/OS DFSMShsm Storage Administration</i></li> </ul>
<b>Application-level tasks</b>	<b>Condition</b>	<b>Procedure reference</b>
<p>For programs that use dynamic allocation and cannot take advantage of predefined data class definitions, set the PARM for the DALINCHG text unit key in DALINCHG to specify the media type and recording technology for system-managed tape library allocations.</p>	Optional	<i>z/OS MVS Programming: Authorized Assembler Services Guide</i>



---

## Chapter 3. Access method services (AMS) modifications for TS1140 tape drives

This topic describes changes to the access method services (AMS) commands to support the TS1140 tape drives. The changed commands are:

- “ALTER LIBRARYENTRY”
- “ALTER VOLUMEENTRY” on page 32
- “CREATE LIBRARYENTRY” on page 32
- “CREATE VOLUMEENTRY” on page 33
- “DCOLLECT” on page 34
- “LISTCAT” on page 34

**Attention:** Use these AMS commands only to recover from tape volume catalog errors. Because AMS cannot change the library manager inventory in an automated tape library, use ISMF for normal tape library alter functions.

**Related reading:**

For explanations of all the parameters used with the AMS commands and additional examples, refer to *z/OS DFSMS Access Method Services Commands*.

---

### ALTER LIBRARYENTRY

Use the AMS ALTER LIBRARYENTRY command to modify the attributes for an existing tape library entry.

The NUMBERSCRATCHVOLUMES parameter and the SCRATCHTHRESHOLD parameter now accept the MEDIA11, MEDIA12, and MEDIA13 subparameters for the IBM System Storage family of tape media.

The maximum value for the NUMBEREMPTYLOTS and NUMBERSLOTS parameters of the ALTER LIBRARYENTRY command has been increased from 999999 to 9999999.

### Changed parameters for ALTER LIBRARYENTRY

**NUMBERSCRATCHVOLUMES(MEDIA1(num) MEDIA2(num) MEDIA3(num) MEDIA4(num) MEDIA5(num) MEDIA6(num) MEDIA7(num) MEDIA8(num) MEDIA9(num) MEDIA10(num) MEDIA11(num) MEDIA12(num) MEDIA13(num))**

This shows the new MEDIA11, MEDIA12, and MEDIA13 subparameters associated with the NUMBERSCRATCHVOLUMES parameter.

**SCRATCHTHRESHOLD(MEDIA1(num) MEDIA2(num) MEDIA3(num) MEDIA4(num) MEDIA5(num) MEDIA6(num) MEDIA7(num) MEDIA8(num) MEDIA9(num) MEDIA10(num) MEDIA11(num) MEDIA12(num) MEDIA13(num))**

This shows the new MEDIA11, MEDIA12, and MEDIA13 subparameters associated with the SCRATCHTHRESHOLD parameter.

**NUMBEREMPTYLOTS(nnnnnnn)**

The maximum value for the NUMBEREMPTYLOTS parameter has been increased from 999999 to 9999999.

**NUMBERSLOTS(nnnnnnn)**

The maximum value for the NUMBERSLOTS parameter has been increased from 999999 to 9999999.

---

## ALTER VOLUMEENTRY

Use the AMS ALTER VOLUMEENTRY command to modify the attributes for an existing tape volume entry.

Enterprise format 4 (EFMT4) and enterprise encrypted format 4 (EEFMT4) are new recording technologies used by the TS1140 tape drive. EFMT4 is the non-encrypted recording format and is the default recording format for the TS1140. EEFMT4 is used to specify that the data on the tape is recorded in the encryption format.

The ALTER VOLUMEENTRY command allows recording fields in the volume records of a tape library to be altered with the following rules:

- EFMT4 subparameter indicates READ/WRITE on an EFMT4 track device.
- EEFMT4 subparameter indicates READ/WRITE on an EEFMT4 track device.
- EFMT4 subparameter of RECORDING is only allowed with media types MEDIA9, MEDIA10, MEDIA11, MEDIA12, or MEDIA13. The use of MEDIA1 through MEDIA8 will produce an IDC3226I error message being generated twice, once for EFMT4 and once for the media type. The generation of the two IDC3226I error messages indicates an incompatibility between the EFMT4 subparameter and the media type displayed.
- EEFMT4 subparameter of RECORDING is only allowed with media types MEDIA9, MEDIA10, MEDIA11, MEDIA12, or MEDIA13. The use of MEDIA1 through MEDIA8 will produce an IDC3226I error message being generated twice, once for EEFMT4 and once for the media type. The generation of the two IDC3226I error messages indicates an incompatibility between the EEFMT4 subparameter and the media type displayed.

### EFMT4 and EEFMT4 subparameter for ALTER VOLUMEENTRY

```
RECORDING(18TRACK | 36TRACK | 128TRACK | 256TRACK | 384TRACK | EFMT1 |  
EFMT2 | EEFMT2 | EFMT3 | EEFMT3 | EFMT4 | EEFMT4 | UNKNOWN)
```

This shows the new EFMT4 and EEFMT4 subparameters associated with the RECORDING parameter for ALTER VOLUMEENTRY

---

## CREATE LIBRARYENTRY

Use the AMS CREATE LIBRARYENTRY command to create a tape library entry. Use it only to recover from tape volume catalog errors.

The NUMBERSCRATCHVOLUMES and SCRATCHTHRESHOLD parameters now accept the MEDIA11, MEDIA12, and MEDIA13 subparameters for the IBM System Storage family of tape media.

The maximum value for the NUMBEREMPTYLOTS and NUMBERSLOTS parameters of the CREATE LIBRARYENTRY command has been increased from 999999 to 9999999.

### Changed parameters for CREATE LIBRARYENTRY

```
NUMBERSCRATCHVOLUMES(MEDIA1(num) MEDIA2(num) MEDIA3(num) MEDIA4(num)  
MEDIA5(num) MEDIA6(num) MEDIA7(num) MEDIA8(num) MEDIA9(num) MEDIA10(num)  
MEDIA11(num) MEDIA12(num) MEDIA13(num))
```

This shows the new MEDIA11, MEDIA12, and MEDIA13 subparameters associated with the NUMBERSCRATCHVOLUMES parameter.



**SCRATCHTHRESHOLD(MEDIA1(num) MEDIA2(num) MEDIA3(num) MEDIA4(num)  
MEDIA5(num) MEDIA6(num) MEDIA7(num) MEDIA8(num) MEDIA9(num) MEDIA10(num)  
MEDIA11(num) MEDIA12(num) MEDIA13(num))**

This shows the new MEDIA11, MEDIA12, and MEDIA13 subparameters associated with the SCRATCHTHRESHOLD parameter.

**NUMBEREMPTYLOTS(nnnnnnn)**

The maximum value for the NUMBEREMPTYLOTS parameter has been increased from 999999 to 9999999.

**NUMBERSLOTS(nnnnnnn)**

The maximum value for the NUMBERSLOTS parameter has been increased from 999999 to 9999999.

---

## CREATE VOLUMEENTRY

Enterprise format 4 (EFMT4) and enterprise encrypted format 4 (EEFMT4) are new recording technologies used by the TS1140 tape drive. EFMT4 is the non-encrypted recording format and is the default recording format for the TS1140. EEFMT4 is used to specify that the data on the tape is recorded in the encryption format.

The CREATE VOLUMEENTRY command allows the recording field in the volume records of a tape library to be created with subparameters of EFMT4 or EEFMT4 with the following rules:

- EFMT4 subparameter indicates READ/WRITE on an EFMT4 track device.
- EEFMT4 subparameter indicates READ/WRITE on an EEFMT4 device.
- • EFMT4 is allowed only with media types MEDIA9, MEDIA10, MEDIA11, MEDIA12, or MEDIA13. Any use of MEDIA1 through MEDIA8 will produce an IDC3226I error message being displayed twice, once for EFMT4 and once for the media in question. The double display indicates an incompatibility between the EFMT4 subparameter and the media type displayed.
- • EEFMT4 is allowed only with media types MEDIA9, MEDIA10, MEDIA11, MEDIA12, or MEDIA13. Any use of MEDIA1 through MEDIA8 will produce an IDC3226I error message being displayed twice, once for EEFMT4 and once for the media in question. The double display indicates an incompatibility between the EEFMT4 subparameter and the media type displayed.
- • If MEDIA9 or MEDIA10 are specified and RECORDING is not specified, default to EFMT2 for RECORDING value. Default to EFMT4 for MEDIA11, MEDIA12, and MEDIA13, if recording is not specified.

## EFMT4 and EEFMT4 subparameters for CREATE VOLUMEENTRY

**RECORDING(18TRACK | 36TRACK | 128TRACK | 256TRACK | 384TRACK | EFMT1 |  
EFMT2 | EEFMT2 | EFMT3 | EEFMT3 | EFMT4 | EEFMT4 | UNKNOWN)**

This shows the new EFMT4 and EEFMT4 subparameters associated with the RECORDING parameter for CREATE VOLUMEENTRY.

---

## DCOLLECT

The DCOLLECT command has values added to its definitions for DDRECTE to allow the constants DDCEFMT4 for the EFMT4 recording technology and DDCEEFM4 for the EEFMT4 recording technology. The DCOLLECT command also has values added to its definitions for DDCMEDIA to allow the constants DDCMED11 for media MEDIA11, DDCMED12 for media MEDIA12 and DDCMED13 for media MEDIA13.

### DDCEFMT4 and DDCEEFM4 subparameter for DCOLLECT

#### DDRECTE (DDCEFMT4 | DDCEEFM4)

##### DDCEFMT4

The recording technology is EFMT4. The constant value is 11.

##### DDCEEFM4

The recording technology is EEFMT4. The constant value is 12.

#### DDCMEDIA (DDCMED11 | DDCMED12 | DDCMED13)

##### DDCMED11

MEDIA11

##### DDCMED12

MEDIA12

##### DDCMED13

MEDIA13

---

## LISTCAT

The LISTCAT command is enhanced to display for VOLUME entries:

- the new EFMT4 and EEFMT4 values associated with the RECORDING parameter
- the new MEDIA11, MEDIA12, and MEDIA13 values associated with the MEDIA-TYPE parameter

In addition, when displaying the NUMBERSCRATCHVOLUMES and the SCRATCHTHRESHOLD for the various media types, the display now uses two sets of titles and values, rather than one set included on three lines, as in previous releases. The display now appears as:

```
          MEDIA1  MEDIA2  MEDIA3  MEDIA4  MEDIA5  MEDIA6  MEDIA7  MEDIA8  MEDIA9  MEDIA10
SCRATCH-VOLUME----- xxx    xxx    xxx    xxx    xxx    xxx    xxx    xxx    xxx    xxx
SCR-VOL-THRESHOLD----- xxx    xxx    xxx    xxx    xxx    xxx    xxx    xxx    xxx    xxx

          MEDIA11 MEDIA12 MEDIA13
SCRATCH-VOLUME----- xxx    xxx    xxx
SCRATCH-THRESHOLD----- xxx    xxx    xxx
```

## EFMT4 and EEFMT4 subparameters in List tape volume entries sample output

```

LISTCAT -
  VOLUMEENTRIES
  ALL
IDCAMS  SYSTEM SERVICES                TIME: 11:29:12      09/02/11    PAGE    2
                                     LISTING FROM CATALOG -- SYS1.VOLCAT.V0
VOLUME-ENTRY----V0A2991
  DATA-VOLUME
  LIBRARY-----ATLIB02      RECORDING-----EEFMT4      ERROR-STATUS----NOERROR      CREATION-DATE-2008-04-02
                                MEDIA-TYPE-----MEDIAx      USE-ATTRIBUTE----SCRATCH      ENT-EJ-DATE----- (NULL)
  STORAGE-GROUP---*SCRCH*      COMPACTION----- (YES)      WRITE-PROTECTED--- (NULL)      LAST-MOUNTED----- (NULL)
  CHECKPOINT----- (NULL)      SP-ATTRIBUTE-----NONE      SHELF-LOC----- (NULL)      LAST-WRITTEN----- (NULL)
  LOCATION-----LIBRARY      OWNER----- (NULL)      EXPIRATION----- (NULL)
IDCAMS  SYSTEM SERVICES                TIME: 11:29:12      09/02/11    PAGE    3
                                     LISTING FROM CATALOG -- SYS1.VOLCAT.VGENERAL
  THE NUMBER OF ENTRIES PROCESSED WAS:
    AIX -----0
    ALIAS -----0
    CLUSTER -----0
    DATA -----0
    GDG -----0
    INDEX -----0
    NONVSAM -----0
    PAGESPACE -----0
    PATH -----0
    SPACE -----0
    USERCATALOG -----0
    TAPELIBRARY -----0
    TAPEVOLUME -----1
    TOTAL -----1
  THE NUMBER OF PROTECTED ENTRIES SUPPRESSED WAS 0
IDC0001I FUNCTION COMPLETED, HIGHEST CONDITION CODE WAS 0
IDCAMS  SYSTEM SERVICES                TIME: 11:29:12      09/02/11    PAGE    4
IDC0002I IDCAMS PROCESSING COMPLETE. MAXIMUM CONDITION CODE WAS 0

```

**Note:** MEDIAx represents either MEDIA9, MEDIA10, MEDIA11, MEDIA12, or MEDIA13.



---

## Chapter 4. Tape drive and tape volume allocation modifications for TS1140 tape drives

Changes made to device support, storage management subsystem (SMS), and Multiple Virtual Storage (MVS™) device allocation enable you to allocate the tape drives and tape volumes. Within an IBM tape library environment, your system can fully recognize all supported media types and recording technologies.

---

### Device support modifications

z/OS DFSMS device support provides hardware device-specific code, which allows tape drives, tape volumes, and DASD to interface with z/OS DFSMS. Specifically, it provides:

- The interfacing exits to the input/output supervisor (IOS) and EXCP device support code
- Error recovery procedure routines
- Services to acquire and log statistical and error data
- Services to acquire and display device states
- Utilities for functions like initializing tapes

You can use the MVS DEVSERV command to request basic status information on a device, a group of devices, or storage control units. You can use the QTAPE parameter of the DEVSERV command to display tape device information. Use DEVSERV QTAPE to display the real device type and the emulated device type.

With the DEVSERV QTAPE MED (medium) option, you can display information for the device type, media type, and cartridge volume serial number.

The syntax of the DEVSERV QTAPE command with the MED option is as follows:

```
DS QT,xxx,MED,nnn
```

*xxx*

Represents a three-digit or a four-digit device number in hexadecimal format.

*nnn*

Stands for the number of devices, starting at the address *xxx*, for which the DEVSERV command displays the MED information. The value *nnn* is optional and can be any decimal number from 1 to 256, with 1 as the default value.

DEVSERV QTAPE will display '3592E07' for the real device type, where E07 is the drive model, if the underlying physical device is a 3592 Model E07 (TS1140). If the MEDIUM option is specified for DEVSERV QTAPE command, the real device type will be displayed as '3592-4E'.

Figure 1 on page 38 shows the output of DS QT,960 when a TS1140 (3592 Model E07) tape drive emulates a 3590 Model B1x tape drive.

```

11.20.46 SYSTEM1          DS QT,960
11.20.46 SYSTEM1          IEE459I 11.20.46 DEVSERV QTAPE 760
UNIT DTYPE  DSTATUS CUTYPE  DEVTYPE  CU-SERIAL  DEV-SERIAL ACL LIBID
0960 3590   ON-RDY  3592C06 3592E07* 0178-00030 0178-00030

```

Figure 1. DS QT,960 output

Figure 2 shows the output of DS QT,960,MED when a TS1140 (3592 Model E07) tape drive emulates a 3590 Model B1x tape drive.

```

11.21.21 SYSTEM1          ds qt,960,MED
11.21.21 SYSTEM1          IEE459I 11.21.21 DEVSERV QTAPE 763
UNIT RDTYPE  EDTYPE  EXVLSR  INVLSR  RMEDIA  EMEDIA          WWID
0960 3592-4E 3590-1      1P0694  9      3

```

Figure 2. DS QT,960,MED output

A bit DFVTJAG4 is added to the IHADFVT mapping macro that maps the data facilities vector table. When this bit is set, it indicates that all of the software support for the 3592 Model E07 (TS1140) drive is on the system. This bit is set by the enabling module IECTEPTF, if it is installed.

The IECUCBCX mapping macro is changed to support the TS1140:

- The new EPI value is X'15' - REALJAG4\_EMUL3590

The DDR Swap Exit handles swaps involving the 3592 Model E07 drive and the new recording formats EFMT4 and EEFMT4. Appropriate rules are also put in place for handling a lower technology EFMT2, EFMT3, EEFMT2, or EEFMT3 (MEDIA9 and MEDIA10) request on a 3592 Model E07 to a 3592 Model J, E05, or E06 (as appropriate and as consistent with past 3592 support). Table 5 shows a summary of what swaps are allowed.

Table 5. Format swaps allowed for TS1140

Format	From device	Allowed to device	Message
EFMT1	3592-J	3592-J 3592-2 3592-2E	'MUST SWAP TO A 3592-J OR 3592-2'
EFMT1	3592-2 3592-2E	3592-2 3592-2E	'MUST SWAP TO A 3592-2'
EFMT2	3592-2 3592-2E	3592-2 3592-2E 3592-3E	'MUST SWAP TO A 3592-2 OR 3592-3E'
EEFMT2	3592-2E	3592-2E 3592-3E	'MUST SWAP TO A 3592-2E OR 3592-3E'
EFMT2/EEFMT2 or EFMT3/EEFMT3 (MEDIA5 - MEDIA8)	3592-3E	3592-3E	'MUST SWAP TO A 3592-3E'
EFMT3/EEFMT3 (MEDIA9 - MEDIA10)	3592-3E	3592-3E 3592-4E	'MUST SWAP TO A 3592-3E OR 3592-4E'
EFMT3/EEFMT3 (MEDIA9 - MEDIA10) or EFMT4/EEFMT4	3592-4E	3592-4E	'MUST SWAP TO A 3592-4E'

Table 5. Format swaps allowed for TS1140 (continued)

Format	From device	Allowed to device	Message
EFMT1 EFMT2/EEFMT2 (MEDIA5 - MEDIA10)	3592-3E	3592-3E 3592-4E	'MUST SWAP TO A 3592-3E OR 3592-4E' (Read attempt only - write attempts suppressed in ERP)
EFMT1 EFMT2/EEFMT2 (MEDIA5 - MEDIA8) EFMT3/EEFMT3 (MEDIA5 - MEDIA8)	3592-4E	3592-4E	'MUST SWAP TO A 3592-4E' (Read attempt only - write attempt's suppressed in ERP)

## IOS000I Message with Encryption Failure

If an encryption-related key exchange between the drive and the key manager fails, an IOS000I message is issued indicating that an encryption failure has occurred:

```
IOS000I 07C2,7D,IOE,06,0600,,**,J1G150,ENCREADA 594
804C08C022402751 0806FF0000131415 0017181900000092 2004E82061C42111
ENCRYPTION FAILURE
CU=08 DRIVE=131415 EKM=171819
```

**Note:** The preceding values for CU, DRIVE, and EKM generically represent the byte positions in sense data where the errors would be reported .

The control unit (CU), DRIVE, and EKM error codes are from sense bytes 08, 13-15, and 17-19, respectively. For example:

```
IOS000I 0BD0,60,IOE,01,0E00,,**,JJC046,ATNCMP1
804C08C022402751 0001FF0000000000 0005EE3100000092 2004E82061BA2111
ENCRYPTION FAILURE
CU=00 DRIVE=000000 EKM=05EE31
```

In this example, the error was reported by the encryption key manager (TKLM or IBM Security Key Lifecycle Manager).

For an EKM failure when using TKLM, refer to the "Reported errors" section of the Tivoli Key Lifecycle Manager Information Center. When looking up the EKM failure, use the last two bytes of the error code (for example, EE31 in the example above).

For an EKM failure when using IBM Security Key Lifecycle Manager, refer to the "Reported errors" section of the IBM Secure Key Lifecycle Manager Information Center. When looking up the EKM failure, use the last two bytes of the error code (for example, EE31 in the example above).

For a control unit failure, refer to:

- IBM System Storage 3592-C07 Controller Customer Information Center (<http://publib.boulder.ibm.com/infocenter/etc/cust/index.jsp>)
- *IBM System Storage 3592 Tape Drives and TS1120 Controller Operator Guide*, GA32-0556

Table 30 on page 211 contains error codes for control unit failures.

Table 6. Error codes for control unit failures

Error code	Description	Recovery action
00	Not a control unit reported failure	Refer to the EKM and drive error codes reported in the IOS000I message for failure information.
01	The EKM was not available for an out-of-band key exchange.	Verify the EKM that the control unit is configured to use and also verify the state of that EKM. However, if the intent was to use in-band key management, use the EKM subcommand of the IECIOSxx PARMLIB member or the SETIOS command to specify your key manager(s).
02	Timeout for an out-of-band key exchange	The EKM may have gone down mid-sequence, or there may be a network problem. Verify the state of the EKM and the TCP/IP network. However, if the intent was to use in-band key management, use the EKM subcommand of the IECIOSxx PARMLIB member or the SETIOS command to specify your key manager(s).
03	An in-band key exchange was canceled by the host.	Check for an IOS628E message for further information as to why the in-band proxy may have canceled the key exchange. For additional information on these error codes, see <i>z/OS UNIX System Services Messages and Codes</i> .

For more detailed information about the drive-reported conditions, and also about the EKM-reported conditions, see the Problem Determination section of the *IBM System Storage TS3500 Tape Library Operator Guide*, GA32-0560.

If there are multiple error codes reported, start with the EKM error code.

In addition, any system-managed tape library scratch tape that receives the IOS000I ENCRYPTION FAILURE message along with an IEC512 I/O ERR, remains in a scratch status, but is updated in the Tape Control Data Base (TCDB) with a VOLUME ERROR STATUS of I/O ERROR. This causes it to be placed in the software error category, and the tape is unusable until the I/O ERROR condition is cleared through manual intervention (for example, use ISMF volume ALTER from scratch. Scratch moves the volume from the software error category back to the scratch category). Periodically, use the DISPLAY SMS,LIBRARY command with DETAIL to display the number of scratch volumes in the software error category.



---

## SMS modifications

SMS automates and centralizes storage management. It automatically assigns service requirements and attributes to data when that data is created. SMS configuration services validate, for example, the recording technology value that ISMF specifies in data class definitions.

SMS will support a new recording technology EFMT4 and EEFMT4 and the new media types MEDIA11, MEDIA12 and MEDIA13.

In an IBM tape library environment (automated or manual), use ISMF to specify the new recording formats (EFMT4 and EEFMT4) and the new media types (MEDIA11, MEDIA12 and MEDIA13). Note that the TS1140 (3592 Model E07) tape drive can read in the EFMT1 format (MEDIA5 through MEDIA8), the EFMT2 and EEFMT2 formats (MEDIA5 through MEDIA10), and the EFMT3 and EEFMT3 formats (MEDIA5 through MEDIA10). It can write in the new EFMT4 and EEFMT4 formats (MEDIA9, MEDIA10, MEDIA11, MEDIA12, MEDIA13) and for media interchange, it can also write in the EFMT3 and EEFMT3 formats (MEDIA9 and MEDIA10).

The recording technology attribute and the performance scaling or performance segmentation options can also be specified and used outside of the system-managed tape library environment.

In support of the TS1140 tape drives, SMS configuration services are updated to validate the recording technology values EFMT4 and EEFMT4 and the new media type values MEDIA11, MEDIA12 and MEDIA13.

### In Data Class

With SMS, the system obtains information about the attributes of a data set from the data class for the data set.

When using encryption, any data set attributes you specify on these DD parameters override the corresponding attributes in the data class for the data set:

- KEYLABL1 (key label 1)
- KEYENCD1 (encoding for key label 1)
- KEYLABL2 (key label 2)
- KEYENCD2 (encoding for key label 2)

### Overriding Attributes Defined in the Data Class

For a new data set, you can override the data class attributes defined in the data class for the data set by coding one or more of these DD parameters:

- KEYLABL1 (key label 1)
- KEYENCD1 (encoding for key label 1)
- KEYLABL2 (key label 2)
- KEYENCD2 (encoding for key label 2)

---

## MVS device allocation modifications

MVS device allocation helps prioritize and select tape drives to meet the needs of application programs or system functions. Batch (JCL) or dynamic (SVC99) allocation makes these device needs known to MVS device allocation. MVS device allocation selects the appropriate devices and serializes them for the requester to

use. It can also request that appropriate volumes be mounted on the allocated devices. It accomplishes these tasks by interfacing with SMS, DEVSERV, OAM, MSGDISP, and other system components.

MVS device allocation currently supports multiple types of tape devices. Within an IBM tape library environment, MVS device allocation considers media types and recording technologies when allocating tape drives and tape volumes. For the TS1140 tape drive, the dynamic allocation (SVC 99) volume interchange text unit (DALINCHG) allows you to specify EFMT4 or EEFMT4 for the recording technology and MEDIA9, MEDIA10, MEDIA11, MEDIA12, and MEDIA13 for the media type.

See Table 7 for DALINCHG parameter values appropriate for the TS1140.

*Table 7. Dynamic allocation (DALINCHG) parameter values for tape cartridge media types*

Parameter Value	Recording Technology	Media Type
99 or 0909	EFMT3	MEDIA9
A9 or 0A09	EEFMT3	MEDIA9
B9 or 0B09	EFMT4	MEDIA9
C9 or 0C09	EEFMT4	MEDIA9
09 or 0009	No format	MEDIA9
9A or 090A	EFMT3	MEDIA10
AA or 0A0A	EEFMT3	MEDIA10
BA or 0B0A	EFMT4	MEDIA10
CA or 0C0A	EEFMT4	MEDIA10
0A or 000A	No format	MEDIA10
BB or 0B0B	EFMT4	MEDIA11
CB or 0C0B	EEFMT4	MEDIA11
0B or 000B	No format	MEDIA11
BC or 0B0C	EFMT4	MEDIA12
CC or 0C0C	EEFMT4	MEDIA12
0C or 000C	No format	MEDIA12
BD or 0B0D	EFMT4	MEDIA13
CD or 0C0D	EEFMT4	MEDIA13
0D or 000D	No format	MEDIA13

**Related reading:**

- See *z/OS MVS System Commands* for more information on the DEVSERV QTAPE command.
- See *z/OS MVS Programming: Authorized Assembler Services Guide* for more information about the DALINCHG parameter.
- See *z/OS DFSMS Installation Exits* for more information about the IECUCBCX mapping macro.

---

## JCL DD Statement Parameters and Equivalent Text Units for TS1140

The JCL DD statement parameters and equivalent text units for TS1140 are unchanged from those for the TS1130 and the TS1120. See “JCL DD statement parameters and equivalent text units for TS1120” on page 215.

---

## DSNAME Allocation Text Units for TS1140

The DSNAME allocation text units for TS1140 are unchanged from those for the TS1130 and the TS1120. See “DSNAME Allocation Text Units for TS1120” on page 215.

---

## Verb Code 01 - Non-JCL Dynamic Allocation Functions for TS1140

### Volume Interchange Specification - Key = '006F'

DALINCHG specifies the media type and track recording technique required for system-managed tape library allocation. Whenever possible, IBM suggests that you use an installation-defined DATACLAS construct name to control cartridge media type and track recording technique. Use this key only when it is not possible to use a predefined DATACLAS construct because of the dynamic nature of the program and because the program must control the media type and track recording technique. Contact your storage administrator before using this key.

**Note:** To specify DALINCHG, your program must be APF-authorized, in supervisor state, or running in PSW key 0-7. The specification of DALINCHG will be ignored if a non-system-managed tape volume is allocated.

When you code this key, # must be one, but LEN and PARM can be either 1 byte or 2 bytes in length (the 2-byte PARM length is supported in z/OS V1R12 and above). These PARM values are new for the TS1140:

**B9 or 0B09**

Enterprise Format 4 recording technology requested; Enterprise Extended Tape Cartridge 3592 requested.

**C9 or 0C09**

Enterprise Encrypted Format 4 recording technology requested; Enterprise Extended Tape Cartridge 3592 requested.

**BA or 0B0A**

Enterprise Format 4 recording technology requested; Enterprise Extended WORM Tape Cartridge 3592 requested.

**CA or 0C0A**

Enterprise Encrypted Format 4 recording technology requested; Enterprise Extended WORM Tape Cartridge 3592 requested.

**0B or 000B**

No specific recording technology requested; Enterprise Advanced Tape Cartridge 3592 requested.

**BB or 0B0B**

Enterprise Format 4 recording technology requested; Enterprise Advanced Tape Cartridge 3592 requested.

**CB or 0C0B**

Enterprise Encrypted Format 4 recording technology requested; Enterprise Advanced Tape Cartridge 3592 requested.

**0C or 000C**

No specific recording technology requested; Enterprise Advanced WORM Tape Cartridge 3592 requested.

**BC or 0B0C**

Enterprise Format 4 recording technology requested; Enterprise Advanced WORM Tape Cartridge 3592 requested.

**CC or 0C0C**

Enterprise Encrypted Format 4 recording technology requested; Enterprise Advanced WORM Tape Cartridge 3592 requested.

**0D or 000D**

No specific recording technology requested; Enterprise Advanced Economy Tape Cartridge 3592 requested.

**BD or 0B0D**

Enterprise Format 4 recording technology requested; Enterprise Advanced Economy Cartridge Tape 3592 requested.

**CD or 0C0D**

Enterprise Encrypted Format 4 recording technology requested; Enterprise Advanced Economy Tape Cartridge 3592 requested.

---

## Chapter 5. ISMF modifications for TS1140 tape drive

In ISMF, these applications are modified to support the two new recording formats, EFMT4 and EEFMT4, and the three new media types, MEDIA11, MEDIA12, and MEDIA13:

- Data class define and alter panels
- Mountable tape volume list panel
- Tape library define and alter panels

### Related reading:

- See *z/OS DFSMS OAM Planning, Installation, and Storage Administration Guide for Tape Libraries* for additional information on the ISMF tape library management application.
- See *z/OS DFSMSdfp Storage Administration* for additional information about data classes and the ISMF data class panels.

---

### Data class define and alter panels

A data class is a set of data set allocation attributes and associated values. You can use the ISMF data class panels to define, alter, display, and list a data class. For the TS1140, you can specify (for media types MEDIA9 through MEDIA13) the E4 value for the recording technology attribute EFMT4, and the EE4 value for the recording technology attribute EEFMT4 on the data class define/alter panel. For EEFMT4, a panel is displayed for the user to enter the Key Labels and Encoding Mechanisms. The Performance Scaling and Performance Segmentation data class options can be used with MEDIA9 and MEDIA11. For media interchange, you can specify EFMT3 (E3) or EEFMT3 (EE3) with MEDIA9 and MEDIA10.

---

### Mountable tape volume list panel

On the mountable tape volume list, the value EFMT4 or EEFMT4 can appear in column 9, RECORDING TECHNOLOGY and the value MEDIA11, MEDIA12, or MEDIA13 can appear in column 8, MEDIA TYPE. Existing media types MEDIA9 and MEDIA10 also apply to the new recording formats EFMT4 and EEFMT4.

---

### Tape library define and alter panels

On the Tape Library Define and Tape Library Alter/Redefine panels, Scratch Threshold fields appear for media types MEDIA11, MEDIA12, and MEDIA13.

On the Tape Library display and Tape Library List panels, Scratch Threshold and Scratch Number fields appear for media types MEDIA11, MEDIA12, and MEDIA13.



---

## Chapter 6. OCE modifications for TS1140 tape drive

The z/OS DFSMS Open/Close/End-of-Volume (OCE) component is a set of system routines that builds the control block structure that connects the application, access method, and the operating system. OCE modifications for the TS1140 tape drive (3592 Model E07) include support for the EFMT4 and EEFMT4 recording technologies and the MEDIA11, MEDIA12, and MEDIA13 media types.

### Related reading:

- See *z/OS DFSMS Using Data Sets* and *z/OS DFSMS Using Magnetic Tapes* for additional information about the OCE routines.
- See *z/OS DFSMS Installation Exits* for more information on OCE installation exit parameter lists.
- See *z/OS DFSMS OAM Planning, Installation, and Storage Administration Guide for Tape Libraries* for more information on tape volume records.

---

### Overview

Two new recording formats, EFMT4 and EEFMT4, and three new media types, MEDIA11, MEDIA12, and MEDIA13, are supported by the TS1140 tape drive (3592 Model E07). The new recording formats (supported on MEDIA9 through MEDIA13) are higher density formats that increase cartridge capacities. For media interchange, the TS1140 drive is downward write and read compatible with EFMT3 and EEFMT3 (MEDIA9 and MEDIA10), and downward read compatible with EFMT3 and EEFMT3 (MEDIA5 through MEDIA8), EFMT2 and EEFMT2 (MEDIA5 through MEDIA10), and EFMT1 (MEDIA5 through MEDIA8). EFMT4 is the default recording technology. The TS1140 tape drive is supported only in 3590-1 Model B emulation.

---

### SMS Managed Tape

An SMS managed cartridge Tape Volume Record (TVR) is updated by OPEN and EOVS with the recording technology and media type when opened for output to the first file (beginning of tape) on a TS1140.

---

### WORM support

OPEN processing supports the new WORM MEDIA12 cartridge by honoring specification of the existing WORM related DEVSUP Parmlib member options (ENFORCE\_DC\_MEDIA and MTL\_NO\_DC\_WORM\_OK). This parallels the support for previous WORM cartridges.

---

### Recording Technology Conflict

OPEN and EOVS resolve the incompatible track conflict when an EFMT4 or EEFMT4 formatted cartridge (MEDIA9 and MEDIA10) is mounted on a 3592 Model E05 or 3592 Model E06 drive during OPEN OUTPUT file sequence 1. The load point label structure is rewritten at the drive capable recording technology using the existing volume serial number obtained from the drive sense data.

---

## Multiple Recording Format Capability

When a data set is opened for OUTPUT, file sequence 1, DISP=NEW, OPEN processing will be enhanced to recognize the data class recording technology specification and will explicitly direct the TS1140 to record in the appropriate recording format. By default, the TS1140 will record in the non-encrypted up-level format EFMT4 unless explicitly changed to record in another format. OPEN processing will always send down the recording format specified in data class, and if a recording format is not explicitly specified, EFMT4 will be used.

When writing from BOT (file sequence 1, DISP=OLD.SHR (for volume reuse), because this processing does not go through the data class ACS routine, Open processing will determine whether encryption had previously been used and will ensure that the next usage of the volume is consistent with past usage. If the previous usage of the volume used encryption, OPEN will explicitly set the new encryption format (EEFMT4). OPEN will also obtain and pass the volume's existing key management-related information to the drive (key label and encoding mechanism). If encryption was not used, the default recording format (EFMT4) will be used. This behavior is consistent with past 3592 generation drives.

---

## Cartridge Reuse with DISP=OLDISHR

Cartridge reuse occurs when writing from BOT file sequence 1 with a disposition of DISP=OLD or DISP=SHR. When the mounted cartridge is encrypted, OPEN processing will set the recording technology to EEFMT4 and pass the volume's existing key labels and encoding mechanism to the drive. Additionally, when the mounted MEDIA9 or MEDIA11 cartridge is Performance Scaled or Performance Segmented OPEN will ensure the cartridge maintains the same characteristic on reuse.

---

## OCE Tape Installation Exits

The IFGTPE macro maps the tape log data. Table 8 describes the IFGTPE fields for mapping the installation exit parameter list.

*Table 8. IFGTPE fields for the installation exit parameter list*

Field name	Length and type	Description
TEPMRECTK	FIXED(8)	Recording technology of the mounted volume in binary.  11 - EFMT4 12 - EEFMT4
TEPMMEDT	FIXED(8)	Media type of the mounted volume in binary.  11 - MEDIA11 12 - MEDIA12 13 - MEDIA13
TEPEKBTRV	CHAR(6)	KB traversed from BOT (applies to 3590 architecture devices)
TEPSKBTRV	CHAR(6)	KB traversed from BOT (applies to 3590 architecture devices)



Table 8. IFGTEP fields for the installation exit parameter list (continued)

Field name	Length and type	Description
TEPE4KBYT	CHAR(3)	Bytes written to the volume in 4K increments since volume mounted (applies to 3490 architecture devices)
TEPS4KBYT	CHAR(3)	Bytes written to the volume in 4K increments since volume mounted (applies to 3490 architecture devices)
TEPEMPOS	FIXED(16)	Starting with the 3592 Model E07, media position decimal value n, representing the numerator in the fraction n/65535. This fraction represents the ratio of the distance from the beginning of the volume to the current position rounded down to the nearest 1/65535th.
TEPSMPOS	FIXED(16)	Same as TEPEMPOS.

**Note:** The following main and FILEE (File End on Volume) fields will be changed from FIXED(31) to FIXED(32):

TEPELSTB  
 TEPETBLK  
 TEPMCAPM  
 TEPMCAPP

---

## Multiple Recording Format Capability

For both system managed and standalone environments, during OPEN OUTPUT, file sequence 1, DISP=NEW, OPEN will retrieve the DATACLASS to determine which recording technology (EFMT4 or EEFMT4 or interchange formats EFMT3 or EEFMT3) should be used. For the prevailing recording format, OPEN will issue a command to enable it from load point. In fact, whenever the tape is to be written from load point, OPEN OUTPUT and EOVS will issue a command for the existing or prevailing recording technology. By default EFMT4 is requested.

---

## IEZDEB (second DEB extension)

OPEN processing will set the new IEZDEB bit DEB2XEE4 if the cartridge is encrypted in the EEFMT4 format. OPEN will also set existing bit DEB2XENC if the cartridge is encrypted (regardless of the encryption format used). Refer to the IEZDEB mapping macro for additional bit settings pertaining to the recording format being used.

DEB2XEEG - 3592-E06/E07 WRITING IN EEFMT3 RECTECH  
 DEB2XEE4 - 3592-E07 WRITING IN EEFMT4 RECTECH  
 DEB2XENC - TAPE CARTRIDGE ENCRYPTED

OPEN will also set new bit DEB2XEF3 if the cartridge, on a 3592 Model E07, is written in the lower recording format EFMT3.

DEB2XEF3 - 3592-E07 WRITING IN EFMT3 RECTECH



---

## Chapter 7. DFSMSdss considerations for the TS1140 tape drive

DFSMSdss, a z/OS functional component, allows you to copy, move, dump, and restore data sets and volumes. DFSMSdss is the primary data mover of DFSMS.

The considerations for using DFSMSdss with the TS1140 tape drive are that same as those for the TS1130. See Chapter 20, “DFSMSdss considerations for the TS1130 tape drive,” on page 131.



---

## Chapter 8. DFSMSHsm considerations for the TS1140 tape drive

DFSMSHsm, a z/OS functional component, automatically manages low activity and inactive data in both system-managed and non-system-managed environments. DFSMSHsm also provides automatic backup and recovery of active data in those environments.

DFSMSHsm can use the TS1140 tape drive (3592 Model E07, 3592-4E) for all functions. DFSMSHsm normally uses non-WORM media (MEDIA9, MEDIA11, and MEDIA13) for non-ABARS functions. DFSMSHsm uses all media, including WORM (MEDIA10 and MEDIA12) for ABARS processing. DFSMSHsm can use the WORM media for non-ABARS processing, if specifically allowed by your installation.

This topic describes these considerations for using DFSMSHsm with the TS1140 tape drive:

- “Modifying your SMS data classes”
- “Modifying your dump classes”
- “Input tape utilization” on page 54
- “Requesting information for encrypted volumes and tapes” on page 54
- “Requesting information for dump volumes” on page 55
- “Specifying esoteric tape unit names to DFSMSHsm” on page 56
- “Tape Hardware Emulation” on page 56
- “Specifying how much of a tape DFSMSHsm uses” on page 57
- “Using tape device naming conventions” on page 57
- “Output tape selection” on page 58
- “Output tape utilization” on page 58
- “Allowing DFSMSHsm to use the 3590-1 generic unit when it contains mixed track technology drives” on page 59
- “Recovering overwritten encrypted tapes” on page 60
- “DFSMSHsm tips” on page 60.

---

### Modifying your SMS data classes

To use tape hardware encryption, you must modify your SMS data class definitions to request encryption from the encryption-capable tape drives.

---

### Modifying your dump classes

The method for requesting encryption depends on whether you plan to use hardware encryption or host-based encryption, as follows:

- To request hardware encryption for a dump class, specify it in the SMS data class for the dump data.
- To request host-based encryption for a dump class, use the DFSMSHsm DEFINE DUMPCLASS(ENCRYPT) command. With ENCRYPT, include the RSA or KEYPASSWORD subparameters to specify the type of host-based encryption. ENCRYPT(NONE) specifies host-based encryption should not be done.

If your dump classes are currently defined to use host-based encryption (and possibly host-based compression before encryption), it is recommended that you remove the host-based encryption requests from any dump classes for which you plan to use tape hardware encryption.

During the process of migrating your dump classes to use hardware encryption, you might have some dump classes that are still defined to use host-based encryption, while their associated SMS data classes are defined to use tape hardware encryption. Here, DFSMSdss ignores requests for host-based encryption for these tape volumes and, instead, uses hardware encryption. This processing allows you to complete the migration to hardware encryption without having to modify your dump-requesting jobs. However, removing host-based encryption requests from a dump class when tape hardware encryption is also requested can avoid confusion concerning which process is active.

**Note:**

1. To determine whether hardware encryption or host-based encryption was used for a particular tape volume, check the associated dump volume record (DVL).
2. If more than one dump class is specified (creating more than one dump copy), those dump classes specify host-based encryption, each dump class has a unique data class assigned, and some but not all of the associated data classes request tape hardware encryption, then all dump copies will fail. In other words, tape hardware encryption can override host-based encryption for all dump classes associated with a source volume or none of the dump classes, but it cannot override a subset of those dump classes.

**Related reading:**

- For more information on the DEFINE DUMPCLASS command, see *z/OS DFSMSdfp Storage Administration*.

---

## Input tape utilization

In an SMS environment, the choice of an input drive for a particular tape is controlled by the library and is transparent to DFSMSHsm.

In a non-SMS environment, the choice of drives is controlled by the unit name recorded in the tape's CDS records. This unit name is the name of the original output unit selected by the installation, or its generic equivalent. In a mixed non-SMS environment where more than one tape technology is associated with a generic unit name, you must use esoteric names for the output unit and its associated input unit.

With the TS1140, the drive can utilize MEDIA5 through MEDIA13 as input for all functions although MEDIA6, MEDIA8, MEDIA10, and MEDIA12 are normally only used by the ABARS function. The choice of the correct recording technology when they are mounted on a TS1140 is transparent to DFSMSHsm.

---

## Requesting information for encrypted volumes and tapes

New values EFMT4 and EEMFT4 are added to the SELECT parameter of the DFSMSHsm LIST TTOC command to allow you to list tape volumes with and without tape hardware encryption.

This shows a portion of the syntax for the LIST TTOC command:

**N: TTOC SELECT Optional Parameters:**

NOALTERNATEVOLUME
FAILEDRECYCLE
EXCESSIVEVOLUMES
FAILEDCREATE
DISASTERALTERNATEVOLUMES
ALTERNATEVOLUME
RECALLTAKEAWAY
CAPACITYMODE
EMFT1
EMFT2
EEFMT2
EFMT3
EEFMT3
EFMT4
EEFMT4
ENCRYPTION
NOENCRYPTION

**Related reading:**

For more information on the LIST TTOC command, see *z/OS DFSMSdfp Storage Administration*.

## Displaying EFMT4 and EEFMT4 formatted volumes

You can use the LIST TTOC command to list volumes based on the recording technology used. To list all volumes recorded in EFMT4 format, enter the LIST TTOC command as follows:

```
LIST TTOC SELECT(EFMT4) ODS(ttoc.out.dataset)
```

To list all volumes recorded in EEFMT4 format, enter the LIST TTOC command as follows:

```
LIST TTOC SELECT(EEFMT4) ODS(ttoc.out.dataset)
```

## Displaying encrypted tape volumes

You can use the LIST TTOC command to list tape volumes that were encrypted through hardware encryption. To do so, enter the LIST TTOC command as follows:

```
LIST TTOC SELECT(ENCRYPTION) ODS(ttoc.out.dataset)
```

You can also use the LIST TTOC command to list tape volumes that were not encrypted through hardware encryption. To do so, enter the LIST TTOC command as follows:

```
LIST TTOC SELECT(NOENCRYPTION) ODS(ttoc.out.dataset)
```

---

## Requesting information for dump volumes

For a list of the information for a specific dump volume managed by DFSMSHsm, specify the LIST command with the DUMPVOLUME(*volser*) parameter. If the volume was tape hardware encrypted, the ENC field will indicate THW.

For a list of the information for the dump volumes of the requested status managed by DFSMSHsm, specify the LIST command with the DUMPVOLUME parameter without the volume serial number. Instead, include a status parameter such as AVAILABLE, UNAVAILABLE, EXPIRED, UNEXPIRED, or NORETENTIONLIMIT. The command lists the volumes in alphanumeric sequence by volume serial number.

**Related reading:**

For more information on the LIST DUMPVOLUME command, see *z/OS DFSMSdfp Storage Administration*

---

## Specifying esoteric tape unit names to DFSMSHsm

When using the SETSYS USERUNITTABLE command to specify esoteric tape unit names to DFSMSHsm, note that DFSMSHsm rejects mixed combinations of device names in an esoteric group, with these exceptions:

- It allows the use of both 3480 and 3480X device names in a single group. Improved Data Recording Capability (IDRC), however, is not used with such a group because all devices in the group are treated as 3480s. If an esoteric group associated only with 3480Xs exists, 3480s should not be added to it, because the data already written using this esoteric tape unit name may create IDRC incompatibilities.
- The following sets of tape units are allowed into the same esoteric because they share common write formats:
  - 3592-1, 3592-2, and 3592-2E tape units, which share EFMT1
  - 3592-2, 3592-2E, and 3592-3E tape units, which share EFMT2 and EEFMT2
  - 3592-3E and 3592-4E tape units, which share EFMT3 and EEFMT3

It is up to the user to ensure the drives in a mixed esoteric will be used with a common recording technology. For example, if any 3592-1 drives are included, then all drives in the esoteric must use EFMT1 for output. If the esoteric mixes 3592-2 and 3592-2E drives, then all drives must be set up to use EFMT1 or EFMT2. If the esoteric contains mixed 3592-2E and 3592-3E tape units, then all drives must be set up to use EFMT2 or EEFMT2, the write formats they have in common. If the esoteric contains mixed 3592-3E and 3592-4E tape units, then all drives must be set up to use EFMT3 or EEFMT3, the write formats they have in common.

**Note:**

1. If DFSMSHsm rejects an esoteric tape unit name, it does not reject the rest of the valid esoteric names specified in the USERUNITTABLE command. Those names are now recognized by DFSMSHsm as valid esoteric tape unit names. Each time you specify USERUNITTABLE, the valid esoteric tape unit names identified with this parameter replace any esoteric tape unit names identified through a previous USERUNITTABLE parameter of the SETSYS command.

**Related reading:**

- For more information on the SETSYS command, see *z/OS DFSMSdfp Storage Administration*.
- 

## Tape Hardware Emulation

- The 3592-E07, along with the 3592-E06 and the 3592-E05, always runs in emulation mode as a 3590-B1x tape drive.
- The 3590-E1x, 3590-H1x, and the 3592-J1A drives emulate either a 3490-E1x or 3590-B1x.



---

## Specifying how much of a tape DFSMShsm uses

**For 3592 devices:** If your installation requires very fast access to data on a MEDIA9 or MEDIA11 tape, consider using the 3592 performance scaling feature. In DFSMShsm, performance scaling applies in both tape libraries and standalone environments.

Performance scaling uses 20% of the physical space on each tape and keeps data sets closer together and closer to the initial load point. Performance scaling permits the same amount of data to exist on a larger number of tapes, allowing more input tasks to run concurrently. With performance scaling, you can effectively increase the “bandwidth” of operations that read data in from tape.

In contrast, performance segmentation allows the use of most of the physical media, while enhancing performance for the first and last portions of the tape.

### Related reading:

- For more information about implementing DFSMShsm tape environments, see *z/OS DFSMSdfp Storage Administration*.

---

## Using tape device naming conventions

Table 9 shows the hardware (marketing device name) and software (MVS generic device name) names for 3592 tape devices. The MVS generic device names are also the names used by the job control language (JCL) to communicate with the z/OS operating system. Use the MVS generic name or your installations esoteric name in any JCL statements or DFSMShsm commands that specify device names.

*Table 9. Tape device naming conventions*

Device description	Hardware name	Generic MVS name
<b>3592-4E</b> <ul style="list-style-type: none"><li>• Enterprise recording format: EFMT1 (readonly), EFMT2 (readonly), EEFMT2 (readonly), EFMT3, EEFMT3, EFMT4, EEFMT4</li><li>• IBM Enterprise tape cartridge: MEDIA5, MEDIA6, MEDIA7, MEDIA8, MEDIA9, MEDIA10, MEDIA11, MEDIA12, MEDIA13</li><li><b>Note:</b> MEDIA5 through MEDIA8 are readonly.</li><li>• Always in "emulation mode" as a 3590 Model B device.</li></ul>	<b>3592-E07</b>	<b>3590-1</b>
<b>3592-3E</b> <ul style="list-style-type: none"><li>• Enterprise recording format: EFMT1 (readonly), EFMT2, EEFMT2, EFMT3, EEFMT3</li><li>• IBM Enterprise tape cartridge: MEDIA5, MEDIA6, MEDIA7, MEDIA8, MEDIA9, MEDIA10</li><li>• Always in "emulation mode" as a 3590 Model B device.</li></ul>	<b>3592-E06</b>	<b>3590-1</b>
<b>3592-2E</b> <ul style="list-style-type: none"><li>• Enterprise recording format: EFMT1, EFMT2, EEFMT2</li><li>• IBM Enterprise tape cartridge: MEDIA5, MEDIA6, MEDIA7, MEDIA8, MEDIA9, MEDIA10</li><li>• Always in “emulation mode” as a 3590 Model B device.</li></ul>	<b>3592-E05</b>	<b>3590-1</b>

Table 9. Tape device naming conventions (continued)

Device description	Hardware name	Generic MVS name
<b>3592-2</b> <ul style="list-style-type: none"> <li>Enterprise recording format: EFMT1, EFMT2</li> <li>IBM Enterprise tape cartridge: MEDIA5, MEDIA6, MEDIA7, MEDIA8, MEDIA9, MEDIA10</li> <li>Always in “emulation mode” as a 3590 Model B device.</li> </ul>	<b>3592-E05</b>	<b>3590-1</b>
<b>3592-J</b> <ul style="list-style-type: none"> <li>Enterprise recording format: EFMT1</li> <li>IBM Enterprise tape cartridge: MEDIA5, MEDIA6, MEDIA7, MEDIA8</li> <li>In “emulation mode” as a 3590 Model B device (or 3490E tape drives with MEDIA5 tape cartridge media only). In a system-managed tape library environment (manual or automated), only 3590 Model B emulation is supported.</li> </ul>	<b>3592-J1A</b>	<b>3590-1</b>

---

## Output tape selection

DFSMSHsm can select TS1140 tape drives (3592-4E) for output in SMS and non-SMS tape environments.

---

## Output tape utilization

DFSMSHsm writes to 97% of the capacity of MEDIA9, MEDIA10, MEDIA11, MEDIA12, and MEDIA13 tapes unless otherwise specified by the installation. Other percentages can be specified through the SETSYS TAPEUTILIZATION command, depending on the particular needs of the installation.

## Scratch Tapes

The TS1140 can use scratch MEDIA9, MEDIA11, and MEDIA13 tapes for all DFSMSHsm functions. It can also utilize scratch MEDIA10 and MEDIA12 tapes for ABARS. The TS1140 can write in EFMT3, EEFMT3, EFMT4, and EEFMT4 recording technologies. The recording technology used on scratch media is controlled by the data class assigned to the tape by the ACS routines. If no recording technology is specified the default of EFMT4 is used.

The ACS routines often use the single file format tape data set name to make the data class selection. This control is transparent to DFSMSHsm.

## Partial Tapes

When the TS1140 uses a partial tape for output, the existing data on tape may be in the EFMT3, EEFMT3, EFMT4, or EEFMT4 recording technologies. The tape will be extended in the same format. The choice of the correct recording technology will be transparent to DFSMSHsm. MEDIA10 and MEDIA12 tapes are normally (unless patched by the customer) used only by ABARS and only as scratch tapes. MEDIA11, MEDIA12, and MEDIA13 partial tapes are always recorded using EFMT4 or EEFMT4 technology.

Earlier technology 3592 drives might use MEDIA9 and MEDIA10 partial tapes. DFSMShsm checks the recording format already on the tape against the capabilities of the drive to ensure the drive is capable of extending the tape. If not, DFSMShsm rejects the partial tape.

---

## Input tape utilization

With the TS1140, the drive can use MEDIA5 through MEDIA13 as input for all functions, although MEDIA6, MEDIA8, MEDIA10, and MEDIA12 are normally only used by the ABARS function. The choice of the correct recording technology when they are mounted on a TS1140 is transparent to DFSMShsm.

## Reuse Capacity

The current scheme has one reuse capacity for each media type regardless of the recording technology. This encourages media used with multiple recording technologies to move from older to newer technologies. This scheme will continue with TS1140.

## Mixed Device Esoteric Units

Keeping with the philosophy of allowing only write compatible tape devices to coexist in the same esoteric, TS1140 drives will be allowed in the same esoteric with TS1130 drives but not allowed in the same esoteric with TS1120 or 3592-J1A drives. The read-only compatibility between the TS1140 and TS1120 and 3592-J1A does not meet the write-compatibility requirements for a mixed esoteric. In a stand-alone (non IBM library) tape environment, the user must make sure all drives in a mixed esoteric will use a recording technology they have in common when they write data to tape. For TS1140 and TS1130 drives the common recording technologies for read and write are EFMT3 and EEFMT3.

---

## Allowing DFSMShsm to use the 3590-1 generic unit when it contains mixed track technology drives

You might encounter a situation in which you need to use the 3590-1 generic unit when it contains a mixture of 3590 devices that cannot share tapes. If so, you must use other means, such as SMS ACS routines, to keep these drives separate, and you can use this patch to disable the DFSMShsm compatibility checking:

```
PATCH .MCVT.+3D5 BITS(.1.....)
```

You can use this patch to re-enable the DFSMShsm compatibility checking:

```
PATCH .MCVT.+3D5 BITS(.0.....)
```

By default, checking is enabled for non-SMS tape allocations.

A non-SMS tape allocation for a generic unit 3590-1 containing mixed track technologies causes DFSMS to issue message ARC0030I. Here, DFSMShsm allows the allocation to continue, but a tape/tape unit mismatch can result in an OPEN failure.

DFSMSHsm does not issue message ARC0030I for a mix of 3592-1, 3592-2, and TS1120 tape units, nor for a mix of 3592-2, TS1120, and TS1130 tape units, nor for a mix of TS1130 and TS1140 tape units, since they can write using a common recording technology.

---

## Recovering overwritten encrypted tapes

Recovery of overwritten encrypted tape volumes might not be possible; the tape recovery process described in the topic "Case 6: Overwritten Migration Tape" of *z/OS DFSMSdfp Storage Administration* does not work for an encrypted tape.

---

## DFSMSHsm tips

See "DFSMSHsm tips" on page 313 for some tips that you might find helpful when using DFSMSHsm with the TS1140 tape drive.

---

## Chapter 9. DFSMSrmm modifications for TS1140 tape drive

DFSMSrmm is a feature of z/OS. It manages all tape media, such as cartridge system tapes and 3420 reels, and other removable media that you define to it. The DFSMSrmm modifications for the TS1140 tape drive include updates to:

- DFSMSrmm TSO subcommands
- REXX variables of the TSO subcommand
- API structured field introducers
- Mapping macros fields

**Note:** References to the new recording formats (EFMT4 and EEFMT4) and to the new media type (MEDIA11, MEDIA12) are applicable at z/OS V1R11 and above, whereas changes pertaining to physical size, physical space used, compression, and block counts are applicable only at z/OS V1R12 and above.

### Related reading:

- See *z/OS DFSMSrmm Managing and Using Removable Media* for the complete syntax of the DFSMSrmm ADDVOLUME subcommand, the DFSMSrmm CHANGEVOLUME subcommand, the DFSMSrmm SEARCHVOLUME subcommand, DFSMSrmm return codes and reason codes, and REXX variables.
- See *z/OS DFSMSrmm Application Programming Interface* for further information about the DFSMSrmm API.
- See *z/OS DFSMSrmm Implementation and Customization Guide* and *z/OS DFSMSrmm Reporting* for additional information about DFSMSrmm mapping macros.

---

## DFSMSrmm TSO subcommands

This section describes the updates to these DFSMSrmm TSO subcommands:

- ADDVOLUME
- CHANGEVOLUME
- SEARCHVOLUME
- ADDDATASET
- CHANGEDATASET
- LISTDATASET
- LISTVOLUME

### ADDVOLUME

The ADDVOLUME TSO subcommand adds volumes to the DFSMSrmm control data set. This diagram shows the syntax of the MEDIATYPE operand and the RECORDINGFORMAT operand for the ADDVOLUME TSO subcommand.

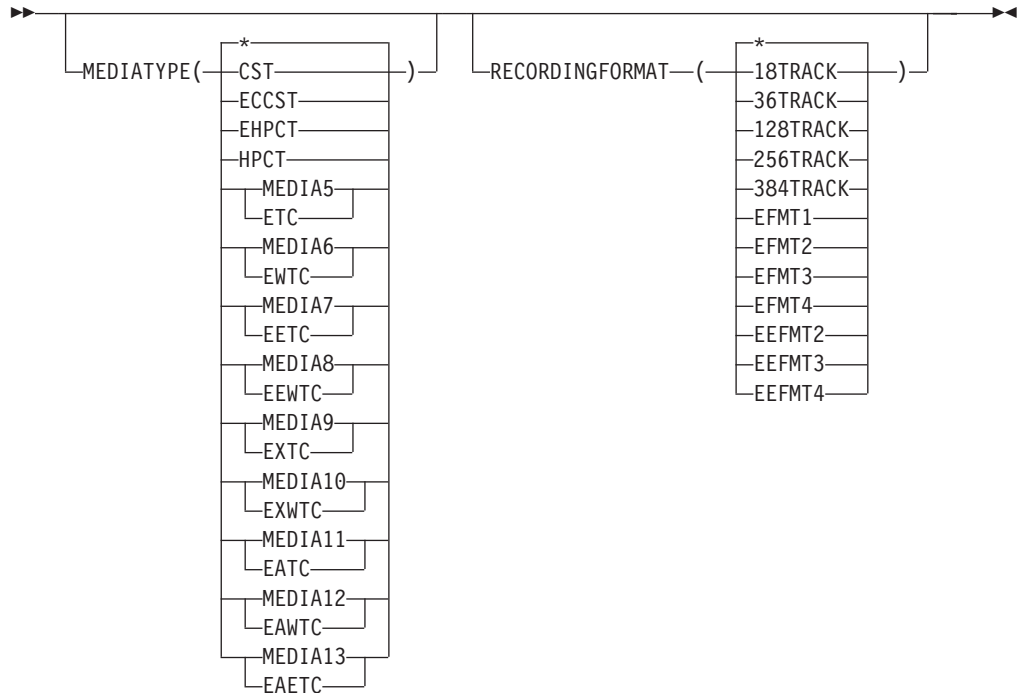

#### **RECORDINGFORMAT (EFMT4)**

Data has been written to the volume in EFMT4 (enterprise format 4) recording format. A recording format of EFMT4 is valid with existing MEDIATYPE(MEDIA9 | MEDIA10) and new MEDIATYPE (MEDIA11 | MEDIA12 | MEDIA13) only.

#### **RECORDINGFORMAT (EEFMT4)**

Data has been written to the volume in EEFMT4 (enterprise encrypted format 4) recording format. A recording format of EEFMT4 is valid with existing MEDIATYPE(MEDIA9 | MEDIA10) and new MEDIATYPE (MEDIA11 | MEDIA12 | MEDIA13) only.

#### **MEDIATYPE (MEDIA11 | EATC)**

IBM Enterprise Advanced Tape Cartridge. MEDIA11 is valid only with a recording format of EFMT4 or EEFMT4.

#### **MEDIATYPE (MEDIA12 | EAWTC)**

IBM Enterprise Advanced WORM Tape Cartridge. MEDIA12 is valid only with a recording format of EFMT4 or EEFMT4.

#### **MEDIATYPE (MEDIA13 | EAETC)**

IBM Enterprise Advanced Economy Tape Cartridge. MEDIA13 is valid only with a recording format of EFMT4 or EEFMT4.

To use the EFMT4 and the EEFMT4 recording technology, you must specify the MEDIATYPE(MEDIATYPE(MEDIA9 | MEDIA10 | MEDIA11 | MEDIA12 | MEDIA13)) operand of the ADDVOLUME TSO subcommand.

## **CHANGEVOLUME**

The CHANGEVOLUME TSO subcommand updates details for a volume defined to DFSMSrmm. This diagram shows the syntax of the MEDIATYPE operand and the RECORDINGFORMAT operand for the CHANGEVOLUME TSO subcommand.

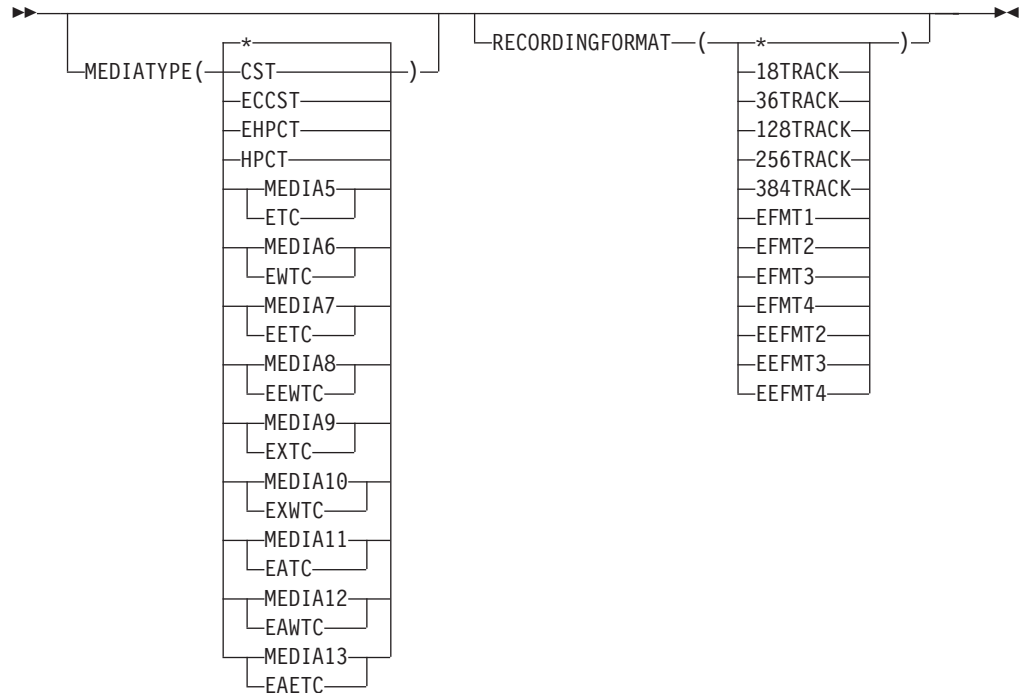

#### **RECORDINGFORMAT (EFMT4)**

Data has been written to the volume in EFMT4 (enterprise format 4) recording format. A recording format of EFMT4 is valid with existing MEDIATYPE(MEDIA9 | MEDIA10) and new MEDIATYPE (MEDIA11 | MEDIA12 | MEDIA13) only.

#### **RECORDINGFORMAT (EEFMT4)**

Data has been written to the volume in EEFMT4 (enterprise encrypted format 4) recording format. A recording format of EEFMT4 is valid with existing MEDIATYPE(MEDIA9 | MEDIA10) and new MEDIATYPE (MEDIA11 | MEDIA12 | MEDIA13) only.

#### **MEDIATYPE(MEDIA11 | EATC)**

IBM Enterprise Advanced Tape Cartridge. MEDIA11 is valid only with a recording format of EFMT4 or EEFMT4.

#### **MEDIATYPE(MEDIA12 | EAWTC)**

IBM Enterprise Advanced WORM Tape Cartridge. MEDIA12 is valid only with a recording format of EFMT4 or EEFMT4.

#### **MEDIATYPE(MEDIA13 | EAETC)**

IBM Enterprise Advanced Economy Tape Cartridge. MEDIA13 is valid only with a recording format of EFMT4 or EEFMT4.

To use the EFMT4 and the EEFMT4 recording technology, you must specify the MEDIATYPE(MEDIA9, MEDIA10, MEDIA11, MEDIA12, MEDIA13) operand of the CHANGEVOLUME TSO subcommand.

## **SEARCHVOLUME**

You can use the SEARCHVOLUME TSO subcommand to obtain a list of volumes that match selection criteria that you specify. Specify EEFMT4 to limit your search to volumes that are written in the EEFMT4 recording technology. You can also specify a particular media type, such as MEDIA11, to then further limit your

search. This diagram shows the syntax of the MEDIATYPE operand and the RECORDINGFORMAT operand for the SEARCHVOLUME TSO subcommand.

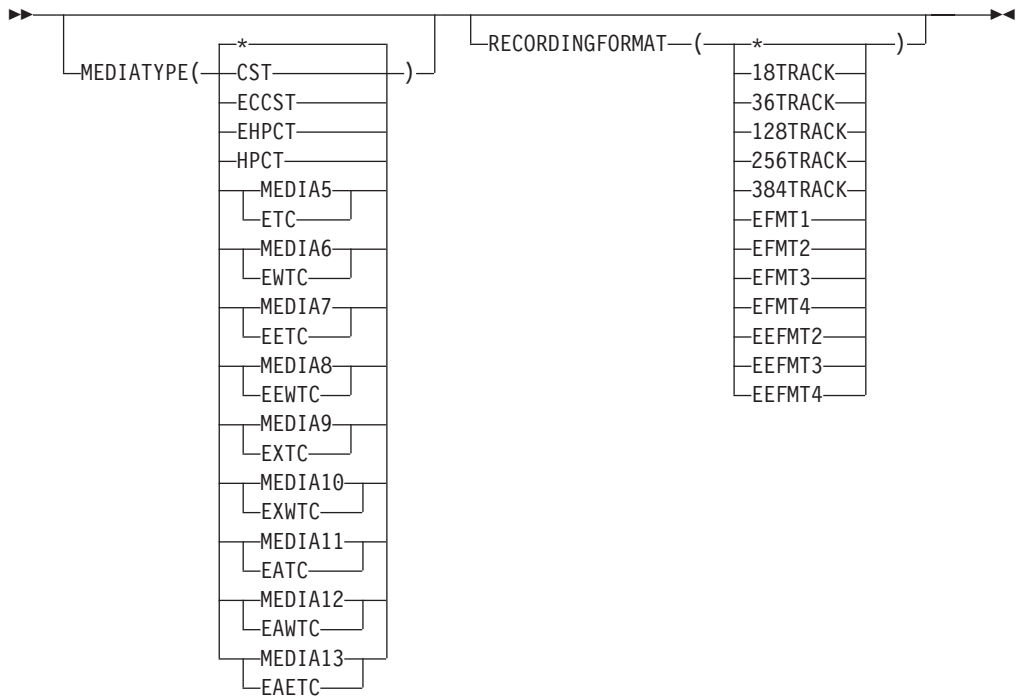

#### RECORDINGFORMAT (EFMT4)

Data has been written to the volume in EFMT4 (enterprise format 4) recording format. A recording format of EFMT4 is valid with existing MEDIATYPE(MEDIA9 | MEDIA10) and new MEDIATYPE (MEDIA11 | MEDIA12 | MEDIA13) only.

#### RECORDINGFORMAT (EEFMT4)

Data has been written to the volume in EEFMT4 (enterprise encrypted format 4) recording format. A recording format of EEFMT4 is valid with existing MEDIATYPE(MEDIA9 | MEDIA10) and new MEDIATYPE (MEDIA11 | MEDIA12 | MEDIA13) only.

#### MEDIATYPE(MEDIA11 | EATC)

IBM Enterprise Advanced Tape Cartridge. MEDIA11 is valid only with a recording format of EFMT4 or EEFMT4.

#### MEDIATYPE(MEDIA12 | EAWTC)

IBM Enterprise Advanced WORM Tape Cartridge. MEDIA12 is valid only with a recording format of EFMT4 or EEFMT4.

#### MEDIATYPE(MEDIA13 | EAETC)

IBM Enterprise Advanced Economy Tape Cartridge. MEDIA13 is valid only with a recording format of EFMT4 or EEFMT4.

## ADDDATASET

Use the ADDDATASET TSO subcommand to manually define a data set on a volume to DFSMSrmm. The volume on which the data set resides must have either master or user status.

#### BLKCOUNT(*number\_of\_blocks*)

Specifies the number of data blocks used by the data set. The value



corresponds to that recorded in the data set's End of File label. The minimum allowable decimal value is 0; the maximum allowable decimal value is 4294967295. DFSMSrmm uses BLKCOUNT, together with BLKSIZE, to calculate the approximate size of the data set and the sum of all data set sizes to set the volume usage. If you do not use BLKCOUNT, DFSMSrmm cannot list the space used for the data set or volume when you request it. The default value is 0.

**Note:** The total block count cannot be set or changed by subcommand. It is set based on information recorded during CLOSE processing.

## CHANGEDATASET

Use the CHANGEDATASET TSO subcommand to update information about data sets defined to DFSMSrmm.

### **BLKCOUNT** (*number\_of\_blocks*)

Specifies number of data blocks used by the data set. The value corresponds to that recorded in the data set's End of File label. The minimum allowable decimal value is 0; the maximum allowable decimal value is 4294967295. DFSMSrmm uses BLKCOUNT together with BLKSIZE to calculate the data set's approximate size and the sum of all data set sizes to set the volume usage.

### **TOTALBLKCOUNT** (*count*)

Use this operand to add a block count for a complete tape data set. The total block count is the sum of all block counts for all volumes on which the data set resides. The minimum allowable decimal value is 0. The maximum allowable decimal value is 18446744073709551615.

**Note:** When this operand is specified, the FORCE operand must also be specified if DFSMSrmm has automatically recorded information about the volume during O/C/EOV processing of a data set on the volume. To use the FORCE operand, you must have CONTROL access to the STGADMIN.EDG.MASTER security resource and UPDATE access to the STGADMIN.EDG.FORCE security resource.

## LISTDATASET

You can use the LISTDATASET TSO subcommand to display information that is recorded by DFSMSrmm for a single data set. In addition to the previously displayed information, LISTDATASET now also displays **Physical size (KB)** and **Compression** fields. Also the maximum size for **Total block count** is increased to 20 digits.

To request information recorded by DFSMSrmm for the data set ADSM.BFS on volume MAA269, issue the command:

```
RMM LISTDATASET 'ADSM.BFS' volume(MAA269)
```

DFSMSrmm displays information such as that shown:

```
Data set name = ADSM.BFS
Volume       = MAA269           Physical file sequence number = 1
Owner        =                  Data set sequence = 1
Create date  = 04/29/2011 Create time = 17:51:00 System ID      = EDS1
Expiration date = 05/29/2011 Original expir. date =
Block size   = 262144          Block count      = 1
Data set size(KB) = 256
Physical size(KB) = 85          Compression      = 3.01
Percent of volume = 0          Total block count = 12345678901234567890
```

```

Logical Record Length = 0           Record Format           = U
Date last written     = 04/29/2011 Date last read        = 04/29/2011
Job name              = ADSM         Last job name         = ADSM
Step name             = ADSM         Last step name        = ADSM
Program name          = DSMSERV       Last program name     = DSMSERV
DD name               = SYS00325     Last DD name          = SYS00325
Device number         = 05C2         Last Device number    = 05C2
Management class     = ATLSMT        VRS management value =
Storage group         = MAS3LIB1     VRS retention date   = 05/01/2012
Storage class         = MEDIA3        VRS retained         = NO
Data class            = ATLSM         ABEND while open     = NO
                                           Catalog status       = UNKNOWN

```

## LISTVOLUME

You can use the LISTVOLUME TSO subcommand to display information that is recorded by DFSMSrmm for a single volume. In addition to the previously displayed information, LISTVOLUME now also displays **Physical (KB)** and **Compression** fields. You must specify a volume serial number.

To request all the information recorded by DFSMSrmm for the encrypted volume with serial number JJC024, issue the command:

```
RMM LISTVOLUME JJC024 ALL
```

DFSMSrmm displays information such as that shown:

```

Volume information:
Volume = JJC024  VOL1 =           Rack = JJC024  Owner = RMMUSER
Type = PHYSICAL      Stacked count = 0          Jobname = D016216J
Worldwide ID =
Creation: Date = 06/28/2011  Time = 04:49:14  System ID = W98MVS2
Assign:   Date =             Time =           System ID = W98MVS2
Expiration date = 09/02/2011 Original =
Retention date =             Set retained = NO
Data set name = RMMUSER.TEST.CBR
Volume status:
Status = USER      Availability =             Label = SL
Current label version =           Required label version =
Media information:
Density = IDRC  Type = EETC      Format = EEFMT3  Compaction = YES
Special attributes = NONE        Vendor =
Encryption Key Labels:                                     Method:
1=wcc1                                                         LABEL
2=wcc2                                                         LABEL
Action on release:
Scratch immediate = N  Expiry date ignore = N
Scratch = Y  Replace = N  Return = N  Init = N  Erase = N  Notify = N
Actions pending:
Scratch = N  Replace = N  Return = N  Init = N  Erase = N  Notify = N
Storage group =
Loan location =           Account = T,H,IOM,,,SYSPROG
Description =
Security class =           Description =
Access information:
Owner access = ALTER  Volume access = NONE  Last change = *OCE
VM use = N  MVS use = Y
Access list:
Statistics:
Number of data sets = 2      Data set recording= ON
Volume usage(MB)= 2         Use count = 3
Physical (KB) = 680       Compression = 3.01
Capacity(MB) = 200          Percent full = 0
Date last read = 08/28/2011 Date last written = 08/28/2011
Drive last used = 0FA0      Write mount count = 2
Volume sequence = 1         Media name = 3480
Previous volume =           Next volume =

```

```

Product number =          Level          = V R M
Feature code   =
Error counts:
Temporary read = 0          Temporary write = 0
Permanent read = 0         Permanent write = 0
Store information:
Movement tracking date =          Intransit = N
In container     =          Move mode = AUTO
Location:  Current      Destination Old      Required      Home
Name       = ATL15393
Type       = AUTO
Bin number =
Media name =

```

---

## DFSMSrmm REXX variables

You can use the REXX variables to obtain volume information. The variables produced by the SEARCHVOLUME subcommand are stem variables.

*Table 10. Changed TSO subcommand REXX variables*

Variable Name	Subcommands	Contents	Format
EDG@BLKT	LD	Total block count	Numeric: up to 10 characters. -1 indicates that BLK6 should be used.
EDG@BLK6	LD	Total block count	Numeric: 0 - 18446744073709551615
EDG@CRAT	LD, LV	Compression ratio in hundredths	Numeric: 0.00 – 999.99  There will always be 2 decimal places.
EDG@MEDR	LV SV	Recording technology	One of *, 18TRK, 36TRK, 128TRK, 256TRK, 384TRK, EFMT1, EFMT2, EEFMT2, EFMT3, EEFMT3, EFMT4, and EEFMT4
EDG@MEDT	LC LV SV	Tape media type	One of *, CST, EAETC, EATC, EAWTC, ECCST, EETC, EEWTC, EHPCT, ETC, EWTC, EXTC, EXWTC, HPCT
EDG@PSZ6	LD LV	Physical space used	Character: Two concatenated fields, <i>factor</i> and <i>value</i> ; where <i>factor</i> is KB, MB, GB, or blank; and <i>value</i> is 0 to 9999999999. For example, GB720.

---

## DFSMSrmm structured field introducers

The DFSMSrmm application programming interface (API) returns data as structured fields in an output buffer that you define. Structured fields consist of a structured field introducer (SFI) and the data. SFIs describe the type, length, and other characteristics of the data.

All Structured Field Introducers (SFIs) have this format:

Bytes	Description
0-1	2-byte length: SFI length plus data length
2-4	3-byte identifier: SFI ID (hexadecimal)

- 5 1-byte type modifier: Type of SFI
  - 0 = 8-byte, fixed-length SFI
- 6 1-byte (Reserved)
- 7 1-byte data type: Type of data, if any, that follows the SFI
  - 0=Undefined (no data)
  - 1=Character (fixed-length)
  - 2=Bit(8) (1-byte flag, multiple bits can be on)
  - 3=Binary(8) (1-byte (hex) value)
  - 4=Binary(15) (2-byte (hex) value)
  - 5=Binary(32) (unsigned 4-byte (hex) value)
  - 6=Binary(64) (unsigned 8-byte (hex) value)
  - 7=Character (variable-length)
  - 8=Compound SFI (multiple related values, see “Compound SFI” on page 69.)
  - 9=(4 bytes) Packed decimal Julian date: yyyydddC
  - A=(4 bytes) Packed decimal time format: hhmmssC

Table 40 on page 245 shows the structured field introducers that support TS1140 tape drives.

Table 11. Changed structured field introducers

Name	Number	Type	Length	Value	Subcommands
BLKT	X'80D030'	Binary(32)	12	Total block count	LD SD
				X'FFFFFFFF' indicates that BLK6 SFI contains the actual value	
BLK6	X'80D0B0'	Binary(64)	16	Total block count	LD
CRAT	X'817890'	Binary(32)	12	Compression ratio in hundreths	LD LV
MEDR	X'857000'	Binary(8)	9	Recording technology: 0=NON-CARTRIDGE 1=18TRK 2=36TRK 3=128TRK 4=256TRK 5=384TRK 6=EFMT1 7=EFMT2 8=EEFMT2 9=EFMT3 10=EEFMT3 11=EFMT4 12=EEFMT4	LC LV SV
MEDT	X'858000'	Binary(8)	9	Media type: 0=UNDEFINED 1=CST 2=ECCST 3=HPCT 4=EHPCT 5=ETC/MEDIA5 6=EWTC/MEDIA6 7=EETC/MEDIA7 8=EEWTC/MEDIA8 9=EXTC/MEDIA9 10=EXWTC/MEDIA10 11=EATC/MEDIA11 12=EAWTC/MEDIA12 13=EAETC/MEDIA13	LV, SV
PSZ6	X'87D300'	Compound (Binary(8) Factor, Binary(64) Value)	22	Physical space used: 0=bytes 1=KB 2=MB 3=GB Value: Minimum value = 0.	LD LV

## Compound SFI

A compound SFI includes multiple values each with own data type and length.

Compound type:

- 1 Factored. A Binary(8) value combined with a second field containing a count. The second field is identified by a data type.

Factor values:

- 0 Bytes (unfactored)
- 1 KB
- 2 MB
- 3 GB
- 4 TB

and so on.

Compound SFIs follow this structure;

### Byte Count

- Description**
- 8 Standard SFI including 1 byte data type identifier (X'08')
- 1 Compound type identifier; 1 = Factored; 2 self describing fields where the first is the factor used, and the second is the resultant value
- 1 Length of the first field, including this byte
- 1 Data type identifier
- n First data field as identified by the preceding data type field; for example Binary(8)
- 1 Length of the next field, including this byte
- 1 Data type identifier
- n Next data field as identified by the preceding data type field; for example Binary(64)

---

## DFSMSrmm macros

Table 41 on page 245 shows the changes made to DFSMSrmm mapping macros for TS1140 tape drives.

*Table 12. DFSMSrmm mapping macro changes*

Mapping Macro	Function	Updates
EDGCDREC	Maps the DFSMSrmm conversion dataset record.	New field: DSNPHYS_SIZE - Physical size of dataset in KB
EDGCLREC	Maps the DFSMSrmm conversion library record.	Recording technology values: EFMT4, EEFMT4.  New fields: LDS1PHYS_SIZE - Physical size of the 1st dataset in KB LVPHYS_USED - Physical space used on volume in KB

Table 12. DFSMSrmm mapping macro changes (continued)

Mapping Macro	Function	Updates
EDGRDEXT	Maps the data set name record in the DFSMSrmm extract data set.	New fields: RDPHYS_SIZE - Actual data on tape after compaction (Factored) RDCOMP_RAT - Compression ratio for the file in hundredths. Always showing 2 decimal places.
EDGRVEXT	Maps the volume records in the DFSMSrmm extract data set.	Recording technology values: EFMT4, EEFMT4. New fields: RVPHYS_USED – Actual space used by all files after compaction (Factored) RVCOMP_RAT - Compression ratio for the volume in hundredths. Always showing 2 decimal places.
EDGRXEXT	Maps the extended data set records in the DFSMSrmm extract data set.	Recording technology values: EFMT4, EEFMT4. New fields: XVPHYS_USED - Actual space used by all files after compaction (factored) XVCOMP_RAT - Compression ratio for the volume in hundredths. Always showing 2 decimal places. XDPHYS_SIZE – Actual data on tape after compaction (factored)
EDGSVREC	Maps the DFSMSrmm SMF volume records.	Recording technology values: EFMT4, EEFMT4. New 64-bit field: MVPHYS_USED - Volume physical space used in KB.
EDGSDREC	Maps the data set information.	New 64-bit field: MDPHYS_SIZE - .Data set physical size in KB
EDGSRCSY	Maps the SMF record symbols used with DFSORT.	Recording technology values: EFMT4, EEFMT4. New fields: MDPHYS_SIZE - .Data set physical size in KB MVPHYS_USED -Volume physical space used in KB

Table 12. DFSMSrmm mapping macro changes (continued)

Mapping Macro	Function	Updates
EDGEXTSY	Maps the extract data set symbols used with DFSORT.	Recording technology values: EFMT4, EEFMT4.  New fields: RDCOMP_RAT - Compression ratio for dataset RDPHYS_SIZE - Physical size of dataset (factored) RVCOMP_RAT-Compression ratio for volume RVPHYS_USED - Physical space used on volume (factored)





---

## Chapter 10. EREP modifications for TS1140 tape drive

Environmental Recording, Editing, and Printing (EREP) program is a diagnostic application program that runs under MVS, VM, and VSE. It generates and prints reports from error recording data set (ERDS) records. With these reports, IBM service representatives can determine the existence, nature, and location of a problem.

This topic describes changes to the TAPE subsystem exception report, emulated device summary report, and TAPE Media Informational Messages (MIMs) of the EREP program to support TS1140 tape drives.

---

### TAPE subsystem exception report

In the following TAPE subsystem exception report, EREP reports a temporary ORB record in support of TS1140 (3592 Model E07) tape drives.

```
TAPE SUBSYSTEM EXCEPTION REPORT                                REPORT DATE 220 11
                                                             PERIOD FROM 076 10
                                                             TO    077 10

*** SEQUENCE BY PROBABLE FAILING UNIT ***

PROBABLE  DEVICE          FAILURE          CPU  DEVNO  -----TOTALS-----
FAILING   TYPE/          AFFECT                /CUA  SIMS  MIMS  OBR  OBR
UNIT      VALID          AFFECT                /CUA  SIMS  MIMS  PERM TEMP
*****

LIBRARY                                TOTAL  0    0    0    1
      3570-CXX  LIBRARY INFORMATIONAL DATA  00  07C2  0    0    0    1

DEVICE                                TOTAL  0    0    2    1
      3590-H1X  LIBRARY DRIVE NOT UNLOADED  02  0C24  0    0    1    0
      3592-J1X  WORM OVERWRITE REJECTED      03  0C27  0    0    0    1
      3592-E06  LIBRARY DRIVE NOT UNLOADED  00  1B90  0    0    0    1
      3592-E07  LIBRARY DRIVE NOT UNLOADED  00  2B90  0    0    0    1
```

Figure 3. TAPE subsystem exception report

---

### Emulated device summary report

In the following emulated device summary report, a TS1140 (3592-E07) tape drive emulates a 3590-B1X tape drive.

```
3590 DEVICE SUMMARY                                REPORT DATE 295 11
                                                             PERIOD FROM 195 10
                                                             TO    195 10

DEVICE ADDRESS  REAL  / EMULATED DEVICE TYPE
0FA2            3592-J1X / 3490-CXX
0FA3            3592-E06 / 3590-B1X
0FA4            3592-E07 / 3590-B1X
```

Figure 4. Emulated device summary report

## TAPE Media Informational Messages (MIMs)

TAPE Media Informational Messages (MIMs) now support TS1140 (3592 Model E07) tape drives, as shown in the following figure.

```
TAPE MEDIA INFORMATION MESSAGES (MIMS)                REPORT DATE 028 11
                                                       PERIOD FROM 023 10
                                                       TO    028 10

*****
VOLUME-JANZ01  DEVICE-0883  DATE-028/11  TIME-06:54:49:45
* D/T-3590-B11      S/N 0113-00001
* SERVICE ALERT    REFCODE-0057  MEDIA IDENTIFIER-0021  FORMAT IDENTIFIER-00
* DATA DEGRADED IN PARTITION 1229
* REFERENCE MEDIA MAINTENANCE PROCEDURE 57

VOLUME-JANZ98  DEVICE-08A9  DATE-028/11  TIME-06:54:49:45
* D/T-359-A00      S/N 0113-23456
* SERIOUS ALERT    REFCODE-0000  MEDIA IDENTIFIER-0073  FORMAT IDENTIFIER-00
* EXCEPTION 00
* REFERENCE MEDIA MAINTENANCE PROCEDURE 00

VOLUME-JANZ99  DEVICE-08A9  DATE-028/11  TIME-06:54:49:45
* D/T-3590/3490EMU S/N 0113-23456
* SERIOUS ALERT    REFCODE-0000  MEDIA IDENTIFIER-0073  FORMAT IDENTIFIER-00
* EXCEPTION 00
* REFERENCE MEDIA MAINTENANCE PROCEDURE 00

VOLUME-SL0001  DEVICE-0DC1  DATE-028/11  TIME-06:54:49:45
* D/T-3592-E07     S/N 0000-00000
* SERVICE ALERT    REFCODE-1011  MEDIA IDENTIFIER-0120  FORMAT IDENTIFIER-01
* EXCEPTION 10
* REFERENCE MESSAGE CODE 10
```

Figure 5. TAPE Media Informational Messages (MIMs)

---

## Chapter 11. JES3 modifications for TS1140 tape drive

JES3, a z/OS MVS subsystem, manages resources and work flow before and after jobs are processed. You can enable JES3 to allocate TS1140 (3592 Model E07) tape drives and tape volumes in an SMS-managed IBM tape library environment (automated or manual) for 3590 Model B emulation only. To do so, you need to specify at least one of these library device group (LDG) names in your JES3plex. An LDG is a predefined set of tape subsystems within a JES3plex.

### **LDN***sssss*

Includes any TS1140 devices with the library indicated by serial number *sssss*.

### **LDG***dddd*

Includes any TS1140 devices (*dddd*=359N) in any library in the JES3plex.

See *z/OS JES3 Initialization and Tuning Reference* for additional information on LDGs, JES3, and JES3plex.



---

## Chapter 12. OAM modifications for TS1140 tape drive

The Object Access Method (OAM) is a component of DFSMSdftp. OAM uses the concepts of system-managed storage, introduced by SMS, to manage, maintain, and verify tape volumes and tape libraries within a tape storage environment. You can also use OAM's object support to manage objects on DASD, tape, and optical volumes.

### Related reading:

- See *z/OS DFSMS OAM Planning, Installation, and Storage Administration Guide for Tape Libraries* for additional information about using OAM to manage tape volumes and tape libraries.
- See *z/OS DFSMS OAM Planning, Installation, and Storage Administration Guide for Object Support* for additional information about using OAM to manage the data on tape volumes.
- See *z/OS MVS System Messages, Vol 4 (CBD-DMO)* for explanations and appropriate actions for CBRxxxxx messages.

---

## OAM library support

OAM uses the concepts of system-managed storage, introduced by SMS, to manage, maintain, and verify tape volumes and tape libraries within a tape storage environment. This topic describes the OAM library support functions that have been changed for use with the TS1140 tape drives. The enhancements include support for two new recording formats, EFMT4 and EEFMT4 and three new media types, MEDIA11, MEDIA12, and MEDIA13.

These steps should be considered when planning to use the new TS1140 (3592-4E) drives:

1. Define the new devices using HCD.
2. Modify your ACS routines to select tape storage groups and libraries with TS1140 (3592-4E) devices.
3. Add, as appropriate, data classes to use the new recording formats (EFMT4 and EEFMT4) and the new media types (MEDIA11, MEDIA12 and MEDIA13) on the new TS1140 (3592-4E) drives. MEDIA9 and MEDIA10 can also be used with EFMT4 and EEFMT4.
4. Add, as appropriate (for media interchange), data classes with EFMT3 and EEFMT3, which can be used on the TS1140 with MEDIA9 and MEDIA10.
5. Specify, as appropriate (for the EEFMT3 or EEFMT4 recording format), the key labels and encoding mechanism for each label.
6. Specify, as appropriate, the read-compatible special attribute indicator for EFMT1 (on MEDIA5 through MEDIA8), EFMT2 and EEFMT2 (on MEDIA5 through MEDIA10), and EFMT3 and EEFMT3 (on MEDIA5 through MEDIA8) formatted volumes. OAM will use the read-compatible special attribute indicator (TDSSPEC) in the tape configuration database (TCDB) or usage of the LABEL=(,,IN) on the DD statement of JCL to determine if a volume is eligible to be read by a TS1140 (3592-4E) device.
7. Contact your tape management system vendor to obtain their support and any modified installation exits.

## LCS external services changes

External Services supports the TS1140 tape drive media types, MEDIA9, MEDIA10, MEDIA11, MEDIA12, and MEDIA13, and the new recording technologies EFMT4 and EEFMT4. It also supports, for media interchange, the older recording technologies EFMT3 and EEFMT3 (on MEDIA9 and MEDIA10). Note that the TS1140 (3592 Model E07) tape drive can only read EFMT1 (on MEDIA5 through MEDIA8), EFMT2 and EEFMT2 (on MEDIA5 through MEDIA10), and EFMT3 and EEFMT3 (on MEDIA5 through MEDIA8) and, as previously indicated, only if the read-compatible special attribute indicator is set, will a TS1140 (3592-4E) device be considered eligible for the volume. The following functions are supported:

- Change use attribute
- Query volume residence
- Test volume eligibility
- Eject a volume
- Manual cartridge entry

### Note:

- The MEDIA9 and MEDIA10 media types are supported with EFMT2 and EEFMT2 (read-only) and EFMT3, EEFMT3, EFMT4 and EEFMT4 (read-write).
- The MEDIA11, MEDIA12, and MEDIA13 media types are valid only with the EFMT4 and EEFMT4 recording technologies.
- The MEDIA5 through MEDIA8 media types are supported only for read requests.
- In general, in an environment sharing the TCDB at different software levels, if a lower-level system without appropriate support attempts to perform one of the CBRXLCS functions using a volume that has EFMT4 or EEFMT4 recording technology (or has a media type of MEDIA11, MEDIA12 or MEDIA13), the request fails with existing return code LCSFAIL (12) and existing reason code LCSFNSUP (310).

## OAM installation exits changes

These installation exits support the EFMT4 and EEFMT4 recording technology and the MEDIA11, MEDIA12 and MEDIA13 media types:

- Change use attribute (CBRUXCUA) installation exit: Tape recording technology fields have been updated with EFMT4 and EEFMT4. The media type fields have been updated for MEDIA11, MEDIA12 and MEDIA13.
- Cartridge entry (CBRUXENT) installation exit: Tape recording technology fields have been updated with EFMT4 and EEFMT4. The media type fields have been updated for MEDIA11, MEDIA12 and MEDIA13.
- Cartridge eject (CBRUXEJC) installation exit: Tape recording technology fields have been updated with EFMT4 and EEFMT4. The media type fields have been updated for MEDIA11, MEDIA12 and MEDIA13.
- Volume not in library (CBRUXVNL) installation exit: Tape recording technology fields have been updated with EFMT4 and EEFMT4. The media type fields have been updated for MEDIA11, MEDIA12 and MEDIA13. For additional information regarding this exit, refer to "Volume not in library installation exit enhancement" on page 332.

## Operator command support changes

Volumes with EFMT4 and EEFMT4 recording technology or media types MEDIA11, MEDIA12 or MEDIA13 are displayed only on systems with full TS1140 tape drive support installed.

These operator tasks have been changed in support of the TS1140 tape drive.

- The DISPLAY LIBRARY DETAIL command displays new scratch counts for MEDIA11, MEDIA12, and MEDIA13.
- The DISPLAY SMS,VOLUME command displays the new EFMT4 and EEFMT4 recording technologies and the new MEDIA11, MEDIA12 and MEDIA13 media types, as appropriate, in the output display for CBR1180I (OAM tape volume status).
- The LIBRARY DISPDRV command displays 3592-4E for the TS1140 tape drive in the output display for CBR1220I (Tape drive status).
- The LIBRARY ENTER command allows MEDIA11, MEDIA12, and MEDIA13 to be set when entering the new media types into a manual tape library.
- The LIBRARY SETCL command allows MEDIA9, MEDIA10, MEDIA11, MEDIA12, and MEDIA13 to be set for a TS1140 tape drive that supports a cartridge loader. (Even though the TS1140 does not have a cartridge loader, when in a tape library environment, the presence of a cartridge loader is simulated.)

## Mount processing change

A TS1140 can both read and write the EFMT3 and EEFMT3 recording formats on MEDIA9 and MEDIA10 or the new EFMT4 and EEFMT4 recording formats on MEDIA9 through MEDIA13. The drive can also read EFMT1 (MEDIA5 through MEDIA8), EFMT2 and EEFMT2 (MEDIA5 through MEDIA10), and EFMT3 and EEFMT3 (MEDIA5 through MEDIA8).

For a DISP=OLD (or DISP=MOD treated as DISP-OLD), if the read-compatible special attribute indicator is not enabled for an EFMT1 request (MEDIA5 through MEDIA8), EFMT2/EEFMT2 request (MEDIA5 through MEDIA10), or EFMT3/EEFMT3 request (MEDIA5 through MEDIA8), device preferencing will occur as it did in prior releases, as the 3592 Model E07 would not be eligible to satisfy the request. Otherwise, if the read-compatible special attribute indicator is enabled, the existing device preferencing lists will be used (oldest to newest drive technology), with the addition of the 3592 Model E07 at the end of the list (at the lowest preference level).

For a DISP=NEW request, a TS1140 tape drive is considered eligible for an EFMT3 or EEFMT3 request (on MEDIA9 and MEDIA10), as well as for the new EFMT4 and EEFMT4 requests (on MEDIA9, MEDIA10, MEDIA11, MEDIA12, and MEDIA13). If a media type is not specified for an EFMT4 or EEFMT4 scratch request, the preference is MEDIA11 followed by MEDIA9, and then MEDIA13, enabling the higher capacity cartridges to be selected first. For an EFMT3 or EEFMT3 request with no media type specified, for a TS1140, MEDIA9 will be the only media type considered.

## OAM macro changes

Table 42 on page 253 describes changes to OAM mapping macros and installation exit parameter lists in support of TS1140 tape drives.

Table 13. OAM mapping macro changes

The macro	that maps	has these changes.
CBRTDSI	the tape device selection information (TDSI)	TDSEFMT4 EQU 11 READ/WRITE ON ENTERPRISE * FORMAT 4 (EFMT4) DEVICE TDSEEFMT4 EQU 12 READ/WRITE ON ENTERPRISE * ENCRYPTED FORMAT 4 (EEFMT4) * DEVICE TDSMED11 EQU 11 MEDIA11 - ENTERPRISE ADVANCED * TAPE CARTRIDGE TDSMED12 EQU 12 MEDIA12 - ENTERPRISE ADVANCED * WORM TAPE CARTRIDGE TDSMED13 EQU 13 MEDIA13 - ENTERPRISE ADVANCED * ECONOMY TAPE CARTRIDGE
CBRTVI	the tape volume information	TVIEFMT4 EQU 11 READ/WRITE ON ENTERPRISE FORMAT 4 * (EFMT4) DEVICE TVIEEFMT4 EQU 12 READ/WRITE ON ENTERPRISE ENCRYPTED * FORMAT 4 (EEFMT4) DEVICE TVIMED11 EQU 11 MEDIA11 - ENTERPRISE ADVANCED * TAPE CARTRIDGE TVIMED12 EQU 12 MEDIA12 - ENTERPRISE ADVANCED * WORM TAPE CARTRIDGE TVIMED13 EQU 13 MEDIA13 - ENTERPRISE ADVANCED * ECONOMY TAPE CARTRIDGE TVISCRMB EQU C'SB' VOLUME IS MEDIA11 SCRATCH TVISCRMC EQU C'SC' VOLUME IS MEDIA12 SCRATCH TVISCRMD EQU C'SD' VOLUME IS MEDIA13 SCRATCH
CBRUXCPL	the change use attribute installation exit parameter list	UXCEFMT4 EQU 11 READ/WRITE ON ENTERPRISE * FORMAT 4 (EFMT4) DEVICE UXCEEFMT4 EQU 12 READ/WRITE ON ENTERPRISE * ENCRYPTED FORMAT 4 (EEFMT4) * DEVICE UXCMED11 EQU 11 MEDIA11 - ENTERPRISE ADVANCED * TAPE CARTRIDGE UXCMED12 EQU 12 MEDIA12 - ENTERPRISE ADVANCED * WORM TAPE CARTRIDGE UXCMED13 EQU 13 MEDIA13 - ENTERPRISE ADVANCED * ECONOMY TAPE CARTRIDGE
CBRUXEPL	the cartridge entry installation exit parameter list	UXEEFMT4 EQU 11 READ/WRITE ON ENTERPRISE FORMAT 4 * (EFMT4) DEVICE UXEEEFMT4 EQU 12 READ/WRITE ON ENTERPRISE ENCRYPTED * FORMAT 4 (EEFMT4) DEVICE UXEMED11 EQU 11 MEDIA11 ENTERPRISE ADVANCED * TAPE CARTRIDGE UXEMED12 EQU 12 MEDIA12 ENTERPRISE ADVANCED * WORM TAPE CARTRIDGE UXEMED13 EQU 13 MEDIA13 ENTERPRISE ADVANCED * ECONOMY TAPE CARTRIDGE
CBRUXJPL	the cartridge eject installation exit parameter list	UXJEFMT4 EQU 11 READ/WRITE ON ENTERPRISE FORMAT 4 * (EFMT4) DEVICE UXJEEFMT4 EQU 12 READ/WRITE ON ENTERPRISE ENCRYPTED * FORMAT 4 (EEFMT4) DEVICE UXJMED11 EQU 11 MEDIA11 - ENTERPRISE ADVANCED * TAPE CARTRIDGE UXJMED12 EQU 12 MEDIA12 - ENTERPRISE ADVANCED * WORM TAPE CARTRIDGE UXJMED13 EQU 13 MEDIA13 - ENTERPRISE ADVANCED * ECONOMY TAPE CARTRIDGE



Table 13. OAM mapping macro changes (continued)

The macro	that maps	has these changes.
CBRUXNPL	the volume not in library installation exit parameter list	<pre> UXNEFMT4 EQU 11 READ/WRITE ON ENTERPRISE FORMAT 4 *          (EFMT4) DEVICE UXNEEFMT4 EQU 12 READ/WRITE ON ENTERPRISE ENCRYPTED *          FORMAT 4 (EEFMT4) DEVICE  UXNMED11 EQU 11 MEDIA11 - ENTERPRISE ADVANCED *          TAPE CARTRIDGE UXNMED12 EQU 12 MEDIA12 - ENTERPRISE ADVANCED *          WORM TAPE CARTRIDGE UXNMED13 EQU 13 MEDIA13 - ENTERPRISE ADVANCED *          ECONOMY TAPE CARTRIDGE           . </pre>

## Cartridge entry processing

When a volume is entered into an IBM automated or manual tape library, the cartridge entry installation exit (CBRUXENT) is invoked to approve or deny an enter request, and to set or verify the recording technology to be associated with a volume.

If a volume TCDB record does not exist for the entry of a private MEDIA9 or MEDIA10 volume, and there is no applicable recording technology being provided by the library's entry default data class, EFMT2 is passed to the exit. If the exit returns with a recording technology for a MEDIA9 or MEDIA10 volume and it is not EFMT2, EEFMT2, EFMT3, EEFMT3, EFMT4, or EEFMT4, the specification is considered invalid and the exit is disabled.

If a volume TCDB record does not exist for the entry of a private MEDIA11, MEDIA12, or MEDIA13 volume, and there is no applicable recording technology being provided by the library's entry default data class, EFMT4 is passed to the exit. If the exit returns with a recording technology for a MEDIA11, MEDIA12, or MEDIA13 volume and it is not EFMT4 or EEFMT4, the specification is considered invalid and the exit is disabled.

If a volume TCDB record does not exist for the entry of a volume and the volume is being entered as a scratch volume, UNKNOWN will be passed to the exit and will be assigned when the volume is used during job processing.

If a TCDB volume record exists and the volume's recording technology or media type is not supported on the system processing the volume, in an ATLDS, the volume is left in the library manager insert category to be processed by a system with appropriate support.

The cartridge entry installation exit (CBRUXENT) is passed by register 1, the pointer to a parameter list mapped by CBRUXEPL.

---

## OAM object tape support

In a stand-alone environment, the SETOAM TAPEUNITNAME parameter in the CBROAMxx member of PARMLIB can be specified using an esoteric that contains TS1140 (3592-4E) tape drives. In the stand-alone environment, 3592 Model J, TS1120 (not encryption capable), TS1120 (encryption capable), TS1130, and TS1140 drives need to be segregated in their own unique esoteric in order to prevent the

allocation of any drive other than a TS1140 for a volume written with EFMT4 or EEFMT4 recording technology, because EFMT4 and EEFMT4 are compatible only with TS1140 drives. In an IBM tape library environment, the SETOAM DATACLASS parameter at the storage group (or global level) can be used to specify a desired recording technology and ensure allocating an appropriate drive.

The ERDS Physical ID (EPI) value for the TS1140 drive is a hex '15' and is stored in the DB2 TAPEVOL table of the OAM Optical Configuration Database (OCDB) for a volume written on the TS1140 drive (in the EFMT4 or EEFMT4 recording formats, as well as the older recording formats EFMT3 and EEFMT3), and displayed, as appropriate, in the volume display. The new media types will also be displayed as MEDIA11, MEDIA12, and MEDIA13, when appropriate. MEDIA11, MEDIA12, and MEDIA13 volumes will be recorded in the DB2 TAPEVOL table as character values '16', '17', and '18', respectively.

---

## Object tape migration considerations

If you choose to encrypt your object data, any partially filled non-encrypted tape volumes associated with an object storage group that you want to encrypt, should be marked full and not writable, so they are not selected. This is important because at the volume level all of the data on the tape is either encrypted or non-encrypted, and a mix of the two cannot reside on the same tape.

Because the 3592 Model E07 is downward write compatible only with EFMT3 and EEFMT3 (on MEDIA9 and MEDIA10), customers may need to mark any partially filled tapes "full " or "not writable" as they migrate to the newer 3592 drive technology and no longer have any devices capable of writing in the older formats. This includes partially filled MEDIA9 or MEDIA10 tapes written in EFMT2 or EEFMT2, and MEDIA5 through MEDIA8 tapes written in EFMT1, EFMT2, EEFMT2, EFMT3, or EEFMT3.

These items should be considered when planning to use TS1140 drives:

If the TS1140 devices are in an IBM tape library:

1. Follow the steps listed in "OAM library support" on page 251 for OAM Library Support.
2. Add new data classes, specifying EFMT3 and EEFMT3 recording technologies.
3. Review ACS routines for STORE, or CTRANS, or both environments for any changes that may be necessary to ensure proper class assignment.

If the TS1140 devices are not in an IBM tape library, use device esoterics for STORAGEGROUP statements in the CBROAMxx member of PARMLIB for the Object storage groups that are to use the new devices. It is important to segregate in an esoteric the different 3592 devices to prevent allocating an inappropriate device for a volume written in the EFMT4 or EEFMT4 recording technology. Add new TAPEUNITNAME with the new device esoteric to the STORAGEGROUP statements in the CBROAMxx PARMLIB member for object storage groups or object backup storage groups that use the new devices.

All partially filled EFMT2 and EEFMT2 volumes (on MEDIA9 and MEDIA10) belonging to a storage group with TS1140 devices assigned need to be marked "full" or "not writeable", as the TS1140 is not downward write-compatible with these recording formats. This will prevent a TS1140 from being selected.

---

## Object tape volume management support

The TS1140 tape drive (for write) supports the existing 3592 media types (MEDIA9 and MEDIA10) plus the new MEDIA11, MEDIA12, and MEDIA13 media types, including special handling of WORM (MEDIA10 and MEDIA12) tape volumes that have expired. You cannot recycle WORM tape volumes because they cannot be written from load point.



---

## Chapter 13. MVS IOS support for TS1140 tape drive

MVS IOS support for the TS1140 tape drive is unchanged from that for the TS1120 tape drive. See Chapter 39, “MVS IOS support for TS1120 tape drive,” on page 257 for more information.



---

## Part 2. TS1130 tape drive





---

## Chapter 14. Introduction for TS1130 tape drive

Like the TS1120 tape drive, the TS1130 provides a tape encryption capability. Data encryption is an important tool for protecting against the possible misuse of confidential information that could occur should tapes be lost or stolen. Unless the possessor of the tape has the required key, any encrypted data on the tape will remain confidential and will be unreadable.

This topic describes the IBM System Storage TS1130 (3592 Model E06, 3592-3E) tape drives and the z/OS software support needed to use them.

---

### TS1130 tape drive

Unlike the TS1120 (3592 Model E05), which can be either encryption capable (3592-2E) or not (3592-2), the TS1130 (3592 Model E06) is always capable of encryption when used by z/OS and always reports as 3592-3E. References in this document to "encryption-capable," means that the encryption feature in the drive had been enabled and the drive is capable of encrypting. In other documents, this may be referred to as "encryption-enabled."

The TS1130 tape drive offers these features:

- Creates tapes for archive files.
- Optionally creates encrypted tapes.
- Backs up and restores systems in case of system or disk storage problems.
- Stores high-speed, high-capacity sequential application data sets.
- Stores temporary data sets.
- Satisfies off-site data storage for disaster recovery.
- Provides data interchange with other systems that use 3592 Model E06 (TS1130) or 3592 Model E05 (TS1120) subsystems. The 3592 Model E06 can also read the 3592 Model J1A (EFMT1) format.
- Supports WORM (write once, read many) tape data cartridges whose data cannot be altered.

The advantages of the TS1130 tape drive over other encryption methods, such as host-based software encryption, are that it:

- Permits full performance of the tape device when encryption is enabled.
- Permits encryption to be performed after compression.
- Avoids performance penalties in the host.

---

### Tape encryption

The TS1130 tape drive supports encryption of media tape cartridges. The existing z/OS DFSMS support for tape subsystem encryption (introduced with the TS1120) allows you to specify by data class that data is to be encrypted. In addition to this, the key label-related information that is used to encrypt the data key (of a tape cartridge) can be specified through the DD statement (JCL, dynamic allocation, and TSO ALLOCATE), data class, or Encryption Key Manager component for the Java platform (EKM) defaults. The communication path to the Encryption Key Manager (EKM) is across TCP/IP, with the choice to go either in-band or out-of-band for the key management flow. With out-of-band key management, the communication path to the Encryption Key Manager is handled by the control unit going directly to the Encryption Key Manager. Then, for in-band key management, the communication path to the Encryption Key Manager is handled across

ESCON/FICON, with an IOS proxy interface then handling the key exchange (across TCP/IP) with the Encryption Key Manager.

**Note:** References in this document to Encryption Key Manager (EKM) also apply to the new Tivoli Key Lifecycle Manager (TKLM). Either key manager can be used with the TS1130 and TS1120 tape drives. The TS1130 requires, at a minimum, version 2.1 of the EKM or version 1.0 of the TKLM. The first release of the TKLM is targeted for 2H2008 (plans are always subject to change).

Unless directed otherwise, a TS1130 tape drive records in the new non-encryption enterprise format 3 (EFMT3). It can also record in the new encryption specific recording format (enterprise encrypted format 3 (EEFMT3)). The EFMT3 and EEFMT3 recording formats are supported across all of the 3592 media types (MEDIA5 - MEDIA10). The existing Performance Scaling and Performance Segmentation data class options, applicable with MEDIA5 and MEDIA9, can also be used with the EFMT3 and EEFMT3 recording formats. The capacities of EMFT3 and EEFMT3 written tapes are the same.

A TS1130 tape drive can also read the existing EFMT1, EFMT2, EEFMT2 recording formats and can be explicitly directed to write from beginning of tape (BOT) in the EFMT2 or EEFMT2 recording format.

When writing from the beginning of tape (BOT), an encryption-capable TS1130 tape drive will, by default, record in the non-encryption recording format (EFMT3). Depending on the host platform and its encryption enablement mechanism, this default can be changed at the drive. However, under z/OS and OPEN processing (file sequence 1, DISP=NEW), unless explicitly requested through data class to record in the lower recording format (EFMT2 or EEFMT2) or the new encryption format (EEFMT3), the non-encryption format EFMT3 will be assumed and explicitly set during OPEN processing. When writing from the beginning of the tape (file sequence 1, DISP=OLD or DISP=SHR for volume reuse), since this processing does not go through the data class ACS routine, OPEN processing will determine whether encryption (EEFMT2 or EEFMT3) had previously been used and ensure that encryption is requested for this next usage of the tape. So, if the previous usage of the tape was encrypted, OPEN will explicitly set the new encryption format (EEFMT3) and will obtain and pass the volume's existing key management-related information to the drive (key label and encoding mechanism). In this case, a new data key is generated and used. However, the volume's existing key management-related information is used to encrypt the data key. This is similar to the way that the encryption format EEFMT2 is handled by the 3592 Model E05 (TS1120) encryption support. This is also consistent with today's 3592 Model E05 drives, where, on reuse, if encryption was not used, the highest non-encryption recording format is specified.

For an encrypted tape cartridge, the cartridge stores both the encrypted user data and the critical key management-related information needed to interact with the Encryption Key Manager when decrypting data on the cartridge. A mix of data written in encrypted and non-encrypted formats is not supported on the same tape cartridge. Whether the data on a cartridge is written in encrypted format is determined during OPEN processing, when the first file sequence on the tape is written. If the first file written to a tape is in the encrypted format; all subsequent files written to that same tape cartridge will be written in the encrypted format. All files written to a cartridge in the encrypted format are encrypted using the same data key. The exception to this is the volume label structure for the first file sequence, which is encrypted using a key known to all encryption capable 3592 drives, which means it is effectively in the clear.

In the TS1130 tape drive environment (whether system-managed or not), when writing from the beginning of tape (file sequence 1, DISP=NEW), to request encryption format, EEFMT3 (or EEFMT2 for downward compatibility) is specified in the data class. OPEN processing passes key management-related information (such as the key labels) to the drive for subsequent communication with the Encryption Key Manager.

To select encryption for a cartridge, do these steps:

1. Define a data class that requests encryption.
2. Modify or create ACS routines to associate the tape output functions using encryption with a data class that requests encryption.
3. Specify the appropriate key labels either through the DD statement (JCL, dynamic allocation, or TSO allocate), data class, or by using Encryption Key Manager established defaults.

---

## Key management for TS1130

Key Management consists of a number of elements including:

- A key store where the keys to encrypt and decrypt the data key are securely kept and readily available.
- An Encryption Key Manager (EKM) that communicates with the drive through the designated key management path (in-band or out-of-band).
- Ability of the tape drive to request and process (with the Encryption Key Manager) key management information.
- A management interface for configuring and managing the Encryption Key Manager (EKM).

### Key store for TS1130

Key store for TS1130 is unchanged from TS1120. See “Key store for TS1120” on page 171 for more information.

### Encryption Key Manager (EKM) for TS1130

Encryption Key Manager (EKM) for TS1130 is unchanged from TS1120, except that EEFMT3 may be specified for the recording format. See “Encryption Key Manager (EKM) for TS1120” on page 171 for more information.

In addition to the Encryption Key Manager (EKM), there is also a new Tivoli Key Lifecycle Manager (TKLM) that can be used with the TS1130 and TS1120 tape drives. References in this document to Encryption Key Manager (EKM) also apply to the new Tivoli Key Lifecycle Manager (TKLM). The TS1130 requires, at a minimum, version 2.1 of the EKM or version 1.0 of the TKLM. Host software including the IOS proxy has no direct knowledge of which key manager is being used. Specification of either key manager is handled the same way, using the EKM keyword on existing IOS commands. The first release of the TKLM is targeted for 2H2008 (plans are always subject to change).

### Tivoli Key Lifecycle Manager (TKLM)

The new Tivoli Key Lifecycle Manager (TKLM) can be used with the new TS1130 (3592 Model E06), as well as the existing TS1120 (3592 Model E05) tape encrypting drives. Like the Encryption Key Manager (EKM), the TKLM serves data keys to the tape drive. The first release of TKLM focuses on ease of use and provides a new graphical interface (GUI) to help with the installation and configuration of the key manager. It also allows for the creation and management of the key encrypting

keys (certificates). Customers using the existing Encryption Key Manager (EKM) can migrate to the new TKLM. For additional information on the TKLM, see the IBM Tivoli Key Lifecycle Manager Information Center.

## In-band proxy for TS1130

In-band proxy for TS1130 is unchanged from TS1120. See “In-band proxy for TS1120” on page 173 for more information.

**Note:** New with the IOS proxy is support for IPv6. Refer to APAR OA22271. This support was added after the initial tape encryption support for the TS1120.

## Management interfaces for TS1130

Management interfaces for TS1130 is unchanged from TS1120. See “Management interfaces for TS1120” on page 174 for more information.

---

## Key label specifications for TS1130

Key label specifications for TS1130 is unchanged from TS1120, except that EEFMT3 (EE3) may be specified for the recording format. See “Key label specifications for TS1120” on page 174 for more information.

---

## Volume label support for TS1130

Volume label support for TS1130 is unchanged from TS1120. See “Volume label support for TS1120” on page 175 for more information.

---

## Volume recovery for TS1130

Volume recovery support for TS1130 is unchanged from TS1120. See “Volume recovery for TS1120” on page 176 for more information.

---

## Re-keying support for TS1130

Re-keying support for the TS1120, which also applies to the TS1130, was introduced after the initial tape encryption support for the TS1120 (APAR OA20076). See “Re-keying support for TS1120” on page 176 for more information on what it means to re-key a tape cartridge. Re-keying is initiated through the IEHINITT utility with a new REKEY option.

---

## Recording format and media support for TS1130 tape drives

The TS1130 tape drive reads and writes in the new EFMT3 (enterprise format 3) and EEFMT3 (enterprise encrypted format 3) recording formats, as well as the existing EFMT2 (enterprise format 2) and EEFMT2 (enterprise encrypted format 2) recording formats. The TS1130 tape drive can also read (but not write) the older EFMT1 (enterprise format 1) recording format. EEFMT3 records data in an encrypted format. EEFMT3 provides the same capacity as EFMT3. The IBM System Storage TS1130 tape drive uses the following IBM System Storage family of tape media:

- MEDIA5 - The IBM TotalStorage Enterprise Tape Cartridge (MEDIA5) physical media. Provides an uncompressed capacity of 640 GB with EFMT3 or EEFMT3 (500 GB with EFMT2 or EEFMT2). Provides a compressed capacity of 1920 GB with EFMT3 or EEFMT3 (1500 GB with EFMT2 or EEFMT2), assuming a 3:1 compression ratio (the compression ratio depends on the type of data written).

- MEDIA6 - The IBM TotalStorage Enterprise WORM Tape Cartridge (MEDIA6) physical media. The MEDIA6 capacity is the same as the MEDIA5 capacity.
- MEDIA7 - The IBM TotalStorage Enterprise Economy Tape Cartridge (MEDIA7) physical media. Provides an uncompressed capacity of 128 GB with EFMT3 or EEFMT3 (100 GB with EFMT2 or EEFMT2). Provides a compressed capacity of 384 GB with EFMT3 or EEFMT3 (300 GB with EFMT2 or EEFMT2), assuming a 3:1 compression ratio (the compression ratio depends on the type of data written).
- MEDIA8 - The IBM TotalStorage Enterprise Economy WORM Tape Cartridge (MEDIA8) physical media. The MEDIA8 capacity is the same as the MEDIA7 capacity.
- MEDIA9 - The IBM TotalStorage Enterprise Extended Tape Cartridge (MEDIA9) physical media. MEDIA9 requires the EFMT2, EFMT3, EEFMT2, or EEFMT3 recording format, and provides an uncompressed capacity of 1000 GB with EFMT3 or EEFMT3 (700 GB with EFMT2 or EEFMT2). Provides a compressed capacity of 3000 GB with EFMT3 or EEFMT3 (2100 GB with EFMT2 or EEFMT2), assuming a 3:1 compression ratio (the compression ratio depends on the type of data written).
- MEDIA10 - The IBM TotalStorage Enterprise Extended WORM Tape Cartridge (MEDIA10) physical media. The MEDIA10 capacity is the same as the MEDIA9 capacity.

You can use the TS1130 tape drive in the stand-alone environment or the tape library environment (automated or manual). Currently, the TS1130 tape drive does not have a cartridge loader. However, in the stand-alone environment, the TS3400 Tape Library provides an automated solution on z/OS. The TS1130 and TS1120 drives in the TS3400 appear to the host as stand-alone 3592 drives with cartridge loaders.

Support for the TS1130 tape drive will be provided at z/OS V1R7 and later releases.

**Note:**

1. If no recording technology has been specified for MEDIA5, MEDIA6, MEDIA7, MEDIA8, MEDIA9, or MEDIA10, EFMT3 is the default recording technology. Other recording formats (EFMT2, EEFMT2, or EEFMT3) can be specified through data class. This applies to both the stand-alone and to the system-managed tape library environments.
2. To enable the EFMT3 and EEFMT3 formatted cartridges to be relabelled/reused from load point on a 3592 Model J1A (3592-1) or a 3592 Model E05 (3592-2 and 3592-2E), drive microcode updates are required on these drives. This is particularly important in a system-managed tape library environment, because common scratch pools are used across the media types.
3. For an encrypted tape cartridge, the cartridge stores both the encrypted user data and the critical key management-related information needed to interact with the Encryption Key Manager when decrypting data on the cartridge. A mix of data written in encrypted and non-encrypted formats is not supported on the same tape cartridge. Whether the data on a cartridge is written in encrypted format is determined during OPEN processing, when the first file sequence on the tape is written. If the first file written to a tape is in the encrypted format; all subsequent files written to that same tape cartridge will be written in the encrypted format. All files written to a cartridge in the encrypted format are encrypted using the same data key. The exception to this

is the volume label structure for the first file sequence, which is encrypted using a key known to all encryption capable 3592 drives, which means it is effectively in the clear.

4. The TS1130 tape drive optionally provides performance scaling by using only 20 percent of the full capacity on a MEDIA5 or MEDIA9 cartridge. The default is to use the cartridge's full capacity. The performance scaling option is not available on MEDIA6, MEDIA7, MEDIA8, or MEDIA10 tape cartridge media.
5. The TS1130 tape drive optionally provides performance segmentation. Performance segmentation divides the cartridge into a fast access segment and a slower access segment. The fast access segment will be filled first, after which the slower segment will be filled. This option is available on MEDIA5 and MEDIA9 tapes, but is not available on MEDIA6, MEDIA7, MEDIA8, or MEDIA10 tape cartridge media. The performance segmentation option is mutually exclusive with the performance scaling option.
6. The TS1130 tape drive emulates only 3590 Model B1x tape drives (all 3592 tape cartridge media are supported in this emulation mode) in the standalone and in the system-managed tape library environment (manual or automated).
7. The TS1130 tape drive is supported by the 3592 Model J70 and C06 tape controllers, with either ESCON<sup>®</sup> or FICON<sup>®</sup> attachment.
8. The TS1130 (3592 Model E06) tape drive coexists with 3490E, 3590, 3592 Model J1A, and 3592 Model E05 (3592-2 and 3592-2E) in the 3494 automated tape library.
9. The TS1130 (3592 Model E06) tape drive coexists with 3592 Model J1A and 3592 Model E05 (3592-2 and 3592-2E) devices in the 3584 automated tape library.
10. The TS1130 (3592 Model E06) tape drive coexists with 3490, 3490E, 3590, 3592 Model J1A, and 3592 Model E05 (3592-2 and 3592-2E) devices in a manual tape library.
11. The TS1130 tape drive cannot use the MEDIA3 or MEDIA4 cartridges used in 3590 tape drives.
12. For the system-managed tape library support (automated or manual), even though a mix of 3592 tape drives (different models) is supported under a single control unit, with z/OS system-managed tape library support, all devices under the same control unit must be homogenous and support the same capabilities. So, although a mix of TS1130 (3592 Model E06) and TS1120 (3592 Model E05) tape drives is supported within the same library, within each control unit, all the devices must be either TS1130 tape drives (only) or TS1120 tape drives (only). In addition to this, all TS1120 tape drives must also be homogeneous so a mix of encryption and non-encryption capable drives is also not supported within a control unit.

**Related reading:**

For additional information, see:

- *IBM System Storage TS1130 Tape Drive and TS1120 Tape Drive and Controller Introduction and Planning Guide 3592 Models J1A, E05, E06, E07, J70 and C06, GA32-0555,*
- *IBM System Storage TS1130 Tape Drive and TS1120 Tape Drive and Controller Operator Guide 3592 Models J1A, E05, E06, E07, J70, and C06*

---

## Performance scaling and segmentation for TS1130

The TS1130 tape drive supports performance scaling and performance segmentation of media tape cartridges. These functions allow you to optimize performance for MEDIA5 and MEDIA9 cartridges; a cartridge can be defined for performance scaling or performance segmentation, but not both.

Except for the cartridge segment sizes for the EFMT3 and EEFMT3 recording formats, performance scaling and segmentation for the TS1130 is the same as for the TS1120. See “Performance scaling and segmentation for TS1120” on page 179 for an overview of performance scaling and segmentation and for information on the cartridge segment sizes for the EFMT2 and EEFMT2 recording formats.

Performance scaling for the TS1130 (3592 Model E06) tape drive limits the data written to the first 20% (the optimally scaled performance capacity) of the cartridge and when using the performance segmentation option, the overall capacity of the cartridge is limited to 86.6% of the total capacity. The fast access segment occupies the first 20% of the cartridge, followed by the slower access segment. So, for example, using EFMT3 or EEFMT3, a MEDIA5 cartridge written on a 3592 Model E06 has a capacity of 640 GB. If the cartridge is performance segmented, the MEDIA5 cartridge is segmented into a 128 GB fast access segment and a 426 GB slower access segment (for a total capacity of 554 GB). By default, the MEDIA5 or MEDIA9 cartridge is used to its full capacity. When written from loadpoint, a scaled or segmented tape cartridge is reformatted according to the assigned data class.

---

## z/OS software support for the TS1130 tape drive

Use z/OS software with the TS1130 tape drive to protect your data with the IBM System Storage family of tape media and the EFMT3 and EEFMT3 recording formats. Table 27 on page 180 describes the software support changes for the new TS1130 tape drive.

**Note:** The software support changes described in “z/OS software support for the encryption-capable TS1120 tape drive” on page 180 also apply to the TS1130.

*Table 14. Components that provide software support for the TS1130 tape drive*

Component	Function
DFSMSdfp AMS	AMS commands, CREATE VOLUMEENTRY, ALTER VOLUMEENTRY, DCOLLECT, and LISTCAT are changed to support the new EFMT3 and EEFMT3 recording technologies. Two new subparameters, EFMT3 and EEFMT3, for the parameter RECORDING, has been added for CREATE VOLUMEENTRY and ALTER VOLUMEENTRY. AMS allows the use of the new EFMT3 and EEFMT3 recording technologies, as well as the printing and displaying of information about the recording technology.
DFSMSdfp Device Services	Device Services manages the IBM System Storage Tape System devices.

Table 14. Components that provide software support for the TS1130 tape drive (continued)

Component	Function
DFSMSdfp ISMF	The ISMF Data Class Application and Mountable Tape Volume Application panels have been enhanced to allow the specification of two new values (E3 for EFMT3 and EE3 for EEFMT3) in the Recording Technology Format field.
DFSMSdfp NaviQuest	NaviQuest sample jobs and CLISTs have been updated to support new EFMT3 and EEFMT3 recording technologies in the data class.
DFSMSdfp OAM	OAM tape library support allows the use of the new EFMT3 and EEFMT3 recording technologies and IBM System Storage family of tape media in the IBM 3494 and 3584 Automated Tape library and in the manual tape library. OAM object tape support allows the use of TS1130 tape drives and media for object-related activity.
DFSMSdfp OCE/IFGOJES3	OCE/IFGOJES3 allows the use of the new EFMT3 and EEFMT3 recording technologies.
DFSMSdfp SMS	SMS allows the use of the new EFMT3 and EEFMT3 recording technologies. You can specify a data class to request data encryption (EEFMT3) or non-encryption (EFMT3) with media types MEDIA5 through MEDIA10. EFMT3 (non-encryption) is the default recording technology for the TS1130.
DFSMSdss	DFSMSdss ensures that encrypted data dumped to a TS1130 tape drive will not be doubly encrypted, unless the user makes specific arrangements for double-encryption.  DFSMSdss Stand Alone Restore will not read a dump data set that resides on an encrypted tape.
DFSMShsm	DFSMShsm allows the use of TS1130 tape drives and media for all DFSMShsm tape related functions. The LIST TTOC SELECT parameters have been extended to take new values EFMT3 (or E3) and EEFMT3 (or EE3).
DFSMSrmm	These DFSMSrmm functions have been enhanced to support the TS1130: <ul style="list-style-type: none"> <li>• The ERASE release action can now be configured to selectively perform a data key shred, a secure data erase, or a combination.</li> <li>• DFSMSrmm TSO subcommands now allow the use of the new EFMT3 and EEFMT3 recording technologies.</li> <li>• REXX variables of the TSO subcommand have been enhanced to support the TS1130</li> <li>• API structured field introducers have been enhanced to support the TS1130, including new compound SFI</li> </ul>



Table 14. Components that provide software support for the TS1130 tape drive (continued)

Component	Function
DFSORT	DFSORT works without change with the IBM System Storage Tape System devices.
EREP	EREP provides unique device type information for TS1130 tape drives when formatting LOGREC records.
z/OS Multiple Virtual Storage (MVS) Allocation	MVS Allocation allows the use of the new EFMT3 and EEFMT3 recording technologies when using the Dynamic Allocation Text Unit DALINCHG.

## Using TS1130 tape drives in an IBM tape library environment

Before using the new TS1130 tape drive, ensure that all existing 3592 Model J1A and E05 drives in the library are upgraded to recognize and enable cartridges formatted for EFMT3 or EEFMT3 to be relabelled/reused on the 3592 Model J1A and E05 drives. Otherwise, job failures may occur with a drive with the incorrect microcode load being allocated.

Because the 3592 Model E06 is only downward read (and not write) compatible with the EFMT1 format, you must specify the read-compatible special attribute indicator (in the tape configuration database) or use LABEL=(,,,IN) on the DD statement of JCL to enable the 3592 Model E06 drive to be considered eligible for an EFMT1 request.

The considerations listed in “Using encryption-capable TS1120 tape drives in an IBM tape library environment” on page 182 also apply to the TS1130.

## Using TS1130 tape drives in a stand-alone environment

Before using the new TS1130 tape drive, ensure that all existing 3592 Model J1A and E05 drives are upgraded to recognize and enable cartridges formatted for EFMT3 or EEFMT3 to be relabelled/reused on the 3592 Model J1A and E05 drives. Otherwise, job failures may occur with a drive with the incorrect microcode load being allocated.

The considerations listed in “Using encryption-capable TS1120 tape drives in a stand-alone environment” on page 183 also apply to the TS1130.

**Recommendation:** Use a manual tape library, DFSMSrmm, third-party tape management software, or write your own applications when using TS1130 tape drives in a stand-alone environment.

---

## Resolving recording technology conflicts for TS1130

3592 Model J1A devices, 3592 Model E05 (TS1120) devices, and 3592 Model E06 (TS1130) devices can all write to MEDIA5-MEDIA8 media types. However, conflicts occur when an EFMT3 or EEFMT3 formatted cartridge is mounted on a 3592 Model J1A or 3592 Model E05 and is being relabelled/reused.

The OPEN and EOVS routines can resolve these recording technology conflicts if you meet these conditions:

- Set OPEN for output to the first file
- Specify VOLNSNS=YES in the DEVSUPxx member of PARMLIB

- Position the tape cartridge at the load point.

If these conditions are met and if the cartridge has an internal *volser* recorded in its volume control region, OPEN and EOVR routines rewrite the VOL1 label with the volume identifier in the sense data.

**Note:** To enable this support, make sure that the 3592 Model J1A devices and 3592 Model E05 devices are at the appropriate microcode level, so that an up-level volume can have its volume identifier returned in the sense data.

For additional information about resolving recording technology conflicts, see *z/OS DFSMS Using Magnetic Tapes* and *z/OS DFSMS Installation Exits*.

---

## Implementation considerations for using TS1130 tape drives

The implementation considerations listed in “Implementation considerations for using encryption-capable TS1120 tape drives” on page 184 also apply to the TS1130.

As appropriate, specify EE3 (EEFMT3 recording format) for encryption or use the media interchange recording technology specification (E2 for EFMT2 or EE2 for EEFMT2) to request that the lower recording formats be used. By default, when writing from load point, EFMT3 (E3) is used by the TS1130 tape drive.

**Related reading:**

See Chapter 15, “Migration to the software support for TS1130 tape drives,” on page 99 for migration information and implementation information.

---

## Chapter 15. Migration to the software support for TS1130 tape drives

DFSMS software support for the TS1130 tape drive addresses media management and data allocation in an IBM 3494 Automated Tape Library, in an IBM 3584 Automated Tape Library, and in the manual tape library (MTL). You can manage media and allocate data to appropriate non-library (stand-alone) drives through segregation of the real and emulating drives, third-party tape management software, or user-written applications. You can use the TS1130 tape drive on systems that are running z/OS V1R7 and above.

This topic outlines the tasks and associated procedures that must be performed to migrate to software support for the TS1130 tape drive in these environments:

- Stand-alone environment
- IBM tape library environment
- HSMplex
- OAMplex
- RMMplex

---

### Understanding coexistence considerations for TS1130

Coexistence support for the TS1130 tape drive is provided at z/OS V1R7 and above by installing the needed full-support PTFs without the Device Services enabling PTF. Coexistence support for DFSMSrmm is also provided at z/OS V1R6. In addition to this, existing device services support prevents the TS1130 tape drives from coming online on a system that does not have all of the full-support PTFs installed. Installation of the Devices Services enabling PTF brings in all of the needed full-support PTFs. See Table 15 on page 100 for a discussion of the coexistence PTFs that may be needed. For past discussion of the 3592 Model J1A and its coexistence considerations, refer to “Understanding coexistence considerations for 3592 Model J1A” on page 347. For past discussion of the 3592 Model E05 and its coexistence considerations, refer to “Understanding coexistence considerations for 3592 Model E05” on page 271 and “Understanding coexistence considerations for encryption-capable TS1120” on page 187.

Review the coexistence migration tasks described in these topics:

Table 15. Coexistence migration tasks for TS1130 tape drives

Environment	Coexistence Considerations
Stand-Alone	<p>As described in Chapter 14, "Introduction for TS1130 tape drive," on page 89, z/OS DFSMS and related licensed programs provide full support for the TS1130 tape drive and MEDIA5, MEDIA6, MEDIA7, MEDIA8, MEDIA9 and MEDIA10. The TS1130 tape drive support enables the tape drives to operate in the stand-alone environment in 3590 Model B1x emulation and to coexist with other emulated tape drives. However, prior to using the new TS1130 tape drive, ensure that all existing 3592 Model J1A and 3592 Model E05 tape drives have their microcode upgraded to recognize and enable the EFMT3 and EEFMT3 formatted cartridges to be relabelled/reused on the 3592 Model J1A and 3592 Model E05. Also, ensure that VOLNSNS=YES is in the DEVSUP:xx member of PARMLIB. Otherwise, job failures may occur with a drive with the incorrect microcode load being allocated.</p> <p>In the stand-alone (non-system managed environment), even though a mix (different models) of 3592 devices is supported under a control unit, IBM recommends that all 3592 devices under the same control unit be homogenous for easier separation and management.</p>
IBM Tape Library	<p>As described in Chapter 14, "Introduction for TS1130 tape drive," on page 89, z/OS DFSMS and related licensed programs provide full support for the TS1130 tape drives and MEDIA5, MEDIA6, MEDIA7, MEDIA8, MEDIA9, and MEDIA10. The system-managed tape library support allows the tape drives to operate in an ATL or MTL environment as 3590 Model B1x devices, providing device allocation and tape media management support. As appropriate for the library type and model, this support allows the TS1130 tape drive to coexist with other emulated 3590-1 tape drives in the same tape library. However, prior to using the new TS1130 tape drive, ensure that all existing 3592 Model J1A and 3592 Model E05 tape drives have their microcode upgraded to recognize and enable the EFMT3 and EEFMT3 formatted cartridges to be relabelled/reused on the 3592 Model J1A and 3592 Model E05. Also, ensure that VOLNSNS=YES is in the DEVSUP:xx member of PARMLIB. Otherwise, job failures may occur with a drive with the incorrect microcode load being allocated.</p> <p>In addition to this, in the system-managed tape library environment, all 3592 drives under the same control unit must have the same recording format capabilities and report under the same ERDS physical identifier (EPI). This ensures that all of the devices under the same control unit are homogeneous and that each device under the same control unit is capable of handling the request. Therefore, a mix of 3592 Model E06 (TS1130) and 3592 Model E05 (TS1120) devices under the same control unit is not supported.</p> <p>A tape configuration database (TCDB) with EFMT3 and EEFMT3 volume records can coexist with lower-level systems. No additional coexistence support is needed. Because the 3592 Model E06 is only downward read (and not write) compatible with the EFMT1 format, you must specify the read-compatible special attribute indicator (in the tape configuration database) or use LABEL=(,,IN) on the DD statement of JCL to enable the 3592 Model E06 drive to be considered eligible for an EFMT1 request.</p>

Table 15. Coexistence migration tasks for TS1130 tape drives (continued)

Environment	Coexistence Considerations
DFSMSdfp Device Services/AOM	<p>Today, the Device Services component prevents any device that has an unknown EPI from coming online. Therefore, if a TS1130 tape drive is attached to a system that does not have any of the TS1130 support installed, the device is not allowed on-line and the following existing message text is issued for message IEA435I:</p> <p>'UNKNOWN DEVICE IN EMULATION MODE NOT BROUGHT ONLINE'</p> <p>When the Device Services full function support APAR is installed without the enabling APAR, the Device Service Exit will recognize the device EPI, but because the enabling APAR that brings all of the software support in is not installed, the device will not come on-line and the following new message text will be issued for IEA435I:</p> <p>'3592-3E DRIVE DETECTED BUT NOT ALL 3592-3E SUPPORT IS PRESENT'.</p>
HSMplex	<p>In an HSMplex, all systems in the HSMplex should have full support for the 3592-3E tape subsystem before any instance of DFSMSshsm uses the new tape drives. If any system does not fully support the 3592-3E, a request for tape input can fail because a 3592-3E device is not available on that system.</p>
OAMplex	<p>For OAM's object support customers, in addition to the planning steps required for migration to the software support for the TS1130 tape drives in the stand-alone and IBM tape library environments, there are coexistence considerations your installation must take into account before you install the software in an OAMplex:</p> <ul style="list-style-type: none"> <li>• For the TS1130 tape drive support, OAM object tape coexistence support is provided at z/OS V1R7 and above, through installation of the full support PTF without the device services enabling PTF. Coexistence and full support systems must also have the new overflow-related columns added to the TAPEVOL table in the Optical Configuration Database (OCDB). Only one system in an OAMplex needs to run CBRSMKBO sample JCL to add the new TAPEVOL columns, but all systems in the OAMplex need to run CBRPBIND.</li> <li>• OAM coexistence support prevents lower-level systems from selecting volumes with ERDS Physical Identifier (EPI) values for object write requests that are not supported on that system.</li> <li>• OAM object support has coexistence considerations when running in an OAMplex environment with at least one system with the full support installed and enabled and at least one system without the full support for the new devices installed and enabled. In this mixed support environment, it is possible for a retrieve request to be received for an object that resides on a tape cartridge volume written in the EFMT3 and EEFT3 format by a system that does not have the TS1130 tape drive full support installed. Coexistence support is provided that allows OAM to attempt to locate an instance of OAM in the OAMplex where the full support is installed and enabled. If an instance of OAM is found where the request can be processed, the OAM on the system where the request originated will ship the retrieve request, if the object is not greater than 50 MB, to the target system using XCF messaging services.</li> <li>• Once TS1130 tape drives devices are used in an OAMplex environment and objects are written to tape volumes with the new EPI value recorded, it is expected that any OAM on a system where the full support is installed and enabled is eligible for processing requests using that volume. Therefore, TS1130 tape drives devices must be available to all instances of OAM where the full support is installed.</li> </ul>
OCE (Open / Close / End-of-Volume)	None.

Table 15. Coexistence migration tasks for TS1130 tape drives (continued)

Environment	Coexistence Considerations
RMMplex	Toleration APAR OA22706 is required for z/OS V1R6 and later releases (all supported releases that can co-exist with z/OS V1R7). This must be installed on all DFSMSrmm systems in an RMMplex prior to the introduction of the new function PTF for this SPE. Unlike other z/OS components changed for 3592 Model E06 support, this coexistence support is needed in RMM even if the 3592 Model E06 drive is not being used.

---

## Preparing to install the software

Refer to *IBM System Storage TS1120/TS1130 Tape Drive and Controller Introduction and Planning Guide 3592 Models J1A, E05, E06, EU6, J70 and C06, GA32-0555*, for hardware requirements. Also refer to the *Encryption Key Manager Introduction, Planning, and User's Guide, GA76-0418*, for Encryption Key Manager requirements.

Coexistence support for the TS1130 tape drive is provided with z/OS V1R7 and above by installing the appropriate full support PTFs without the device services enabling PTF.

---

## Installing the appropriate PTFs

Refer to the 3592 PSP bucket for the APAR and PTF numbers applicable for each release. An enabling PTF exists to provide full device support for the TS1130 tape drive. Installation of the appropriate enabling PTF pulls in all of the needed support PTFs and indicates to the system that all of the needed software support is installed. For z/OS V1R7 and above, refer to enabling APAR OA22119.

In addition, as appropriate for your environment and release level, determine what coexistence PTFs are needed for your environment.

---

## Planning for DFSMS software support for the TS1130 tape drive

The planning steps you must consider to successfully install the TS1130 tape drive software, vary depending upon the tape environment you have installed. Table 16 on page 103 discusses planning considerations for stand-alone environments (including tape devices installed in vendors' automated tape libraries) and for IBM tape library environments.

Table 16. TS1130 tape drive planning considerations

Area	Planning Considerations
System customization: stand-alone environment	<ol style="list-style-type: none"> <li>1. Determine which data needs to be encrypted and set up the appropriate data class policy specifying EEFMT3 (or EEFMT2 for media interchanges). Also specify, as appropriate, the non-encryption recording formats, EFMT3 (or EFMT2 for media interchanges). If a TS1130 tape drive tape drive is allocated, the default recording format is EFMT3. Also, modify or create ACS routines to associate the tape output functions with a data class that has the appropriate recording format specified.</li> <li>2. As appropriate, determine which key labels are to be used and how they will be specified, data class, the DD statement or Encryption Key Manager established defaults.</li> <li>3. Determine whether you will need help from your tape management system vendor and contact them, if needed.</li> <li>4. As appropriate, plan for the installation of the Encryption Key Manager (EKM) and decide which of the supported key stores to use.</li> <li>5. As appropriate, plan for the key labels that will be used and the encoding mechanism (label or hash) for each and where the key labels will be specified.</li> <li>6. For in-band key management (with encryption), update the IOS PARMLIB member (IECIOSxx) using the EKM command. Also create a z/OS UNIX segment for the IOS address space.</li> <li>7. Upgrade 3592 Model J1A and 3592 Model E05 drive microcode to enable the drives to recognize and enable the EFMT3 and EEFMT3 formatted cartridges to be relabelled/reused. Also, ensure that VOLNSNS=YES is in the DEVSUPxx member of PARMLIB.</li> <li>8. Determine which systems should have coexistence support and which systems should have full support.</li> <li>9. Determine when to IPL the host machine after installing the coexistence PTFs, if needed.</li> <li>10. Determine when to IPL the host machine after installing all necessary PTFs.</li> </ol>

Table 16. TS1130 tape drive planning considerations (continued)

Area	Planning Considerations
System customization: IBM library tape environment	<ol style="list-style-type: none"> <li>1. Determine which data needs to be encrypted and set up the appropriate data class policy specifying EEFMT3 (or EEFMT2 for media interchange). Also, specify as appropriate, the non-encryption recording formats, EFMT3 or EFMT2 (for media interchange). If a TS1130 tape drive is allocated, the default recording format is EFMT3. Also, modify or create ACS routines to associate the tape output functions with a data class that has the appropriate recording format specified.</li> <li>2. Because the 3592 Model E06 is only downward read (and not write) compatible with the EFMT1 format, you must specify the read-compatible special attribute indicator (in the tape configuration database) or use LABEL=(,,IN) on the DD statement of JCL to enable the 3592 Model E06 drive to be considered eligible for an EFMT1 request.</li> <li>3. As appropriate, determine which key labels are to be used and how they will be specified, data class, the DD statement or Encryption Key Manager established defaults.</li> <li>4. Determine whether you will need help from your tape management system vendor and contact them, if needed.</li> <li>5. As appropriate, plan for the installation of the Encryption Key Manager (EKM) and decide which of the supported key stores to use.</li> <li>6. As appropriate, plan for the key labels that will be used and the encoding mechanism (label or hash) for each and where the key labels will be specified.</li> <li>7. For in-band key management (with encryption), update the IOS PARMLIB member (IECIOSxx) using the new EKM command. Also create a z/OS UNIX segment for the IOS address space.</li> <li>8. Upgrade 3592 Model J1A and 3592 Model E05 drive microcode to enable the drives to recognize and enable the EFMT3 and EEFMT3 formatted cartridges to be relabelled/reused. Also, ensure that VOLNSNS=YES is in the DEVSUPxx member of PARMLIB.</li> <li>9. Identify the installation exit changes that are needed.</li> <li>10. Determine which systems should have coexistence support and which systems should have full support.</li> <li>11. Determine when to IPL the host machine after installing the coexistence PTFs, if needed.</li> <li>12. Determine when to IPL the host machine after installing all necessary PTFs.</li> </ol>



Table 16. TS1130 tape drive planning considerations (continued)

Area	Planning Considerations
System customization: OAM object tape environment	<p>The planning steps that you must consider in tape environments that use OAM objects vary depending upon the type of environment that is installed.</p> <ol style="list-style-type: none"> <li>1. If you install the TS1130 tape drive devices in a stand-alone environment:               <ol style="list-style-type: none"> <li>a. Follow the system customization planning steps listed for a stand-alone environment.</li> <li>b. Determine the esoteric or generic device names that need to be added to STORAGEGROUP statements in the CBROAMxx member of PARMLIB for the object storage groups that are to use the new devices.</li> <li>c. Determine whether to use the global keyword DSNWITHSGNAME on the SETOAM statement in the CBROAMxx member of PARMLIB to append the object storage group name to the OAM object tape data set names. See “Object tape data set low-level qualifier enhancement” on page 413 for additional information.</li> <li>d. Determine the new data classes that need to be defined in STORAGEGROUP statements in the CBROAMxx member of PARMLIB for the object storage groups that are to use the new encryption format EEFMT3 (by default, the non-encryption recording format EFMT3 is used).</li> </ol> </li> <li>2. If you install the TS1130 tape drive devices in an IBM tape library:               <ol style="list-style-type: none"> <li>a. Follow the system customization planning considerations listed for an IBM tape library environment.</li> <li>b. Determine the new data classes that need to be defined in STORAGEGROUP statements in the CBROAMxx member of PARMLIB for the object storage groups that are to use the new devices and the new encryption format EEFMT3.</li> </ol> </li> <li>3. In addition, if you install the TS1130 tape drive devices in an OAMplex:               <ol style="list-style-type: none"> <li>a. Ensure that the TS1130 tape drive devices are available to all instances of OAM where the full support software is installed.</li> <li>b. Determine whether systems exist that will require coexistence support. This situation is particularly important in an OAMplex where at least one system has the full-support software installed and enabled, and at least one system will not have all of the support installed or enabled. Coexistence support is needed if not all of the systems in the OAMplex will be at the same full-support level.</li> <li>c. To provide this coexistence support, as appropriate for the support and the release level, install the OAM full-support PTF without the enabling PTF or any separate coexistence support PTF.</li> <li>d. Determine when to IPL the host machine after installing the coexistence PTFs, if needed.</li> </ol> </li> <li>4. In an OAM Object Tape environment, any coexistence or full support systems must also have the new overflow-related columns added to the TAPEVOL table in the Optical Configuration Database (OCDB). Only one system in an OAMplex needs to run CBRSMKBO sample JCL to add the new TAPEVOL columns, but all systems in the OAMplex need to run CBRPBIND. Adding the new TAPEVOL columns and running CBRPBIND is needed with the installation of the PTFs regardless of whether the new TS1130 tape drives are being used.</li> </ol>
System customization: DFSMSHsm	See “Implementation considerations for using TS1130 tape drives” on page 98 and “DFSMSHsm tips” on page 233.

Table 16. TS1130 tape drive planning considerations (continued)

Area	Planning Considerations
Storage administration: stand-alone tape environment	<ol style="list-style-type: none"> <li>1. Determine how to setup your tape management systems pooling support to segregate rewritable (MEDIA5, MEDIA7, and MEDIA9) and WORM (MEDIA6, MEDIA8, and MEDIA10) media and also to segregate the standard, economy, and extended length cartridges, as appropriate for your job and application usage.</li> <li>2. Review the usage of the DEVSUP:xx PARMLIB option, ENFORCE_DC_MEDIA, (optional) to ensure that the media type mounted is the media type requested through data class. This can be used in conjunction with the tape management systems pooling support as an additional safety check.</li> <li>3. Review the existing SMS data class media policies to ensure compatibility with existing tape scratch pool policies before enabling the DEVSUP:xx PARMLIB option, ENFORCE_DC_MEDIA.</li> <li>4. Review the existing SMS data class recording technology policies to ensure that data set policies set to EFMT2 and EEFMT2 are being appropriately used. If a TS1130 tape drive is allocated and the specified data class indicates EFMT2 or EEFMT2, the drive will record in the lower recording technology. Also, remember that the TS1130 does not record in the EFMT1 format, so also review any existing SMS data classes that specify EFMT1 for applicability.</li> <li>5. Determine the data class updates that are needed to request the appropriate recording format for the TS1130 tape drives. If a TS1130 tape drive is allocated, the default recording format is EFMT3 (non-encryption).</li> <li>6. Determine if media should use performance segmentation, with a fast access segment to be filled first, and a slower access segment to be filled after. If you decide to use the performance segmentation attribute (available with MEDIA5 and MEDIA9 tape cartridges only, and mutually exclusive with performance scaling), you can: <ol style="list-style-type: none"> <li>a. Define a data class that requests performance segmentation.</li> <li>b. Modify or create ACS routines to associate the tape output functions using performance segmentation with a data class that requests performance segmentation.</li> </ol> </li> <li>7. Determine if media should be used at full capacity or scaled for optimal performance. If you decide to use the performance scaling attribute (available with MEDIA5 and MEDIA9 tape cartridges only), you can: <ol style="list-style-type: none"> <li>a. Define a data class that requests performance scaling.</li> <li>b. Modify or create ACS routines to associate the tape output functions using performance scaling with a data class that requests performance scaling.</li> </ol> </li> <li>8. Determine how to allocate media to appropriate nonlibrary drives. Consider using the IBM manual tape library. You can also segregate the real drives from the emulating drives, use third-party tape management software, or use customer-written applications.</li> <li>9. Identify any needed changes to the hardware configuration definition (HCD) to define the new devices.</li> </ol>

Table 16. TS1130 tape drive planning considerations (continued)

Area	Planning Considerations
Storage administration: IBM tape library environment	<ol style="list-style-type: none"> <li>1. Review the usage of the DEVSUPxx PARMLIB option, MTL_NO_DC_WORM_OK, if the WORM cartridges in the manual tape library environment will be mounted through use of the tape management systems pooling support versus a data class WORM media specification.</li> <li>2. Determine the 3592 media usage of rewritable (MEDIA5, MEDIA7, and MEDIA9) and WORM (MEDIA6, MEDIA8, and MEDIA10) media and also the usage of the standard, economy, and extended length cartridges. Then make the appropriate data class definition updates to select the appropriate media type. WORM media can only be used if explicitly requested through data class.</li> <li>3. Review ACS routines for changes needed in selecting tape storage groups and libraries that have the TS1130 tape drive devices.</li> <li>4. Determine the data class updates that are needed to use the recording technology, media type, and performance scaling or performance segmentation data class attribute (performance scaling or segmentation available with MEDIA5 and MEDIA9 tape cartridges only).</li> <li>5. Identify any needed changes to the HCD to define the new devices.</li> <li>6. To define the partitioning category code for MEDIA5, MEDIA6, MEDIA7, MEDIA8, MEDIA9, and MEDIA10 tape cartridges, specify the appropriate parameter of the DEVSUPxx parmlib member.</li> <li>7. Because the 3592 Model E06 is only downward read (and not write) compatible with the EFMT1 format, you must specify the read-compatible special attribute indicator (in the tape configuration database) or use LABEL=(,,IN) on the DD statement of JCL to enable the 3592 Model E06 drive to be considered eligible for an EFMT1 request.</li> </ol>
Storage administration: OAM object tape environment	<p>The planning steps that you must consider in tape environments that use OAM objects vary depending upon the type of environment that is installed.</p> <ol style="list-style-type: none"> <li>1. If you install the TS1130 tape drive devices in a stand-alone environment, follow the storage administration planning steps listed for a stand-alone environment.</li> <li>2. If you install the TS1130 tape drive devices in an IBM tape library:             <ol style="list-style-type: none"> <li>a. Follow the storage administration planning steps listed for an IBM tape library environment.</li> <li>b. Review ACS routines for STORE or CTRANS environments and make any changes needed to ensure proper class assignment.</li> </ol> </li> <li>3. If you install the TS1130 tape drive devices in an OAMplex, you must make the devices available to all instances of OAM where the full support is installed.</li> </ol>

Implementing this change could affect these areas of your processing environment:

Area	Considerations
Storage Administration	<p>The following NaviQuest CLISTs have changed:</p> <ul style="list-style-type: none"> <li>• ACBQBAD1 is a CLIST used to define, alter, or display a data class.</li> <li>• ACBQBAD2 is a CLIST used to define or alter a data class.</li> </ul> <p>ISMF panels have been changed to support the two new recording formats, EFMT3 and EEFMT3. See Chapter 18, "ISMF modifications for TS1130 tape drive," on page 125 for information about ISMF support for the TS1130 tape drive.</p>

Area	Considerations
Operations	<p>These commands have been updated with this support:</p> <ul style="list-style-type: none"> <li>• DEVSERV QTAPE</li> <li>• DISPLAY SMS,VOLUME</li> <li>• IDCAMS ALTER VOLUMEENTRY</li> <li>• IDCAMS CREATE VOLUMEENTRY</li> <li>• IDCAMS DCOLLECT</li> <li>• IDCAMS LISTCAT</li> <li>• LIBRARY DISPDRV</li> </ul>
Auditing	None.
Application development	<p>The mapping macros and installation exits listed have been changed for this function.</p> <ul style="list-style-type: none"> <li>• CBRTDSI - Maps the Tape Device Selection Information</li> <li>• CBRTVI - Maps the Tape Volume Information</li> <li>• CBRUXCPL - Installation Exit CBRUXCUA Parameter List</li> <li>• CBRUXEPL - Installation Exit CBRUXENT Parameter List</li> <li>• CBRUXJPL - Installation Exit CBRUXEJC Parameter List</li> <li>• CBRUXNPL - Installation Exit CBRUXVNL Parameter List</li> <li>• DALINCHG - Dynamic Allocation DALINCHG Text Unit</li> <li>• EDGRDEXT - DFSMSrmm Data Set Extract record</li> <li>• EDGRVEXT - DFSMSrmm Volume Extract Record</li> <li>• EDGRXEXT - DFSMSrmm Extended Extract record</li> <li>• EDGXSF - DFSMSrmm API SFI definitions</li> <li>• IECUCBCX - Maps the Tape UCB Device Class extension</li> <li>• IFGTEP - Maps the installation exit main parameter list</li> <li>• IEZDEB - Maps the data extent block (DEB)</li> <li>• IHADFVT - Maps the data facilities vector table</li> </ul> <p><b>Tracking Data Written:</b> An application may track in KBs, data such as the number of logical bytes written, the number of physical bytes written, the amount of free space remaining on a volume, the capacity of the volume, or the number of logical bytes deleted. Now, with a 1 TB tape (non-compressed), the possibility exists with the 3592 Model E06 to overflow some of the 4-byte fields that contain these values. Of particular concern would be the logical data-related fields that (with compression) deal with an amount of data that may be larger than the physical capacity of the tape. Applications that use, store, and display this type of information may need to account for and determine how best to handle an overflow situation. For a signed (4-byte) integer X'7F FF FF FF' (2,147,483,647 in KBs) supports 2+ TBs and for an unsigned (4-byte) integer X'FF FF FF FF' (4294967295 in KBs) supports 4+ TBs.</p>
Diagnostic procedures	<p>The messages listed have been changed for this support.</p> <ul style="list-style-type: none"> <li>• CBR0178I</li> <li>• CBR0203I</li> <li>• CBR0206I</li> <li>• CBR0207I</li> <li>• CBR0211I</li> <li>• CBR1083I</li> <li>• CBR1180I</li> <li>• CBR1220I</li> <li>• IEA435I</li> <li>• IEH623E</li> <li>• IEH641I</li> <li>• IGF513I</li> </ul>
Automation products	None.
General use	<p>For DFSMSrmm, use the RMM subcommands ADDVOLUME, CHANGEVOLUME, and SEARCHVOLUME to specify the recording technology EFMT3 or EEFMT3, and for EEFMT3, the key labels KEYLABEL1/KEYENCODE1 and KEYLABEL2/KEYENCODE2.</p>

## Implementing the DFSMS software support for the TS1130 tape drive

To implement the TS1130 tape drives software support, perform the system-level and application-level tasks listed in the following tables. **Required** tasks apply to any DFSMS installation enabling the function. **Optional** tasks apply to only specified operating environments or to situations where there is more than one way to set up or enable the function. For more details on the procedures associated with a given task, see the reference listed.

System-Level Tasks	Condition	Procedure Reference
<i>Stand-alone tape environment</i>	Required	<ul style="list-style-type: none"> <li>• <i>z/OS DFSMS OAM Planning, Installation, and Storage Administration Guide for Object Support</i></li> <li>• <i>z/OS HCD User's Guide</i></li> <li>• <i>z/OS DFSMSShsm Implementation and Customization Guide</i></li> </ul>
<ol style="list-style-type: none"> <li>1. Implement the data class policy specifying EFMT3 or EEFMT3. Also, specify as appropriate, the interchange recording formats, EFMT2 or EEFMT2. Also, modify or create ACS routines to associate the tape output functions with a data class that has the appropriate recording format specified. If no data class is used, EFMT3 will be the recording technology.</li> <li>2. As appropriate, install the Encryption Key Manager (EKM) and set up the key store it will use.</li> <li>3. As appropriate, create the data classes or the DD statements (or use Encryption Key Manager defaults) to specify the key labels and their encoding mechanism (label or hash).</li> <li>4. As appropriate, for in-band key management, update the IOS PARMLIB member (IECIOSxx) using the new EKM command. Also create a z/OS UNIX segment for the IOS address space.</li> <li>5. Upgrade 3592 Model J1A and 3592 Model E05 microcode to enable the drives to recognize and enable the EFMT3 or EEFMT3 formatted cartridges to be relabelled/reused. Also, ensure that VOLNSNS=YES is in the DEVSUPxx member of PARMLIB.</li> <li>6. Make the required installation exit changes.</li> <li>7. Make any needed changes to the HCD to define the new devices.</li> <li>8. If more than one recording technology is used for the same device type, create a unique esoteric for each of the recording technologies. Use the esoteric unit names in DFSMSShsm to direct allocations uniquely to each group of devices.</li> <li>9. If performance scaling or performance segmentation is used (available with MEDIA5 and MEDIA9 tape cartridges only), update or create ACS routines to assign a data class to tape output functions. For example, for DFSMSShsm, you can filter on single file tape data set names used by DFSMSShsm functions. Define the data class with the performance scaling or performance segmentation attribute.</li> <li>10. Add new device esoteric unit names or generic unit names to STORAGEGROUP statements in the CBROAMxx member of PARMLIB for the object storage groups that are to use the new devices. The esoteric or generic unit name must consist of TS1130 tape drives exclusively because the EFMT3 and EEFMT3 recording technologies are not compatible with other devices.</li> <li>11. Install coexistence PTFs as appropriate.</li> <li>12. IPL the system.</li> </ol>		

System-Level Tasks	Condition	Procedure Reference
<p><i>IBM tape library environment</i></p> <ol style="list-style-type: none"> <li>1. Implement the data class policy specifying EFMT3 or EEFMT3. Also, specify as appropriate, EFMT2 or EEFMT2 (for media interchange). Also, modify or create ACS routines to associate the tape output functions with a data class that has the appropriate recording format specified.</li> <li>2. Because the 3592 Model E06 is only downward read (and not write) compatible with the EFMT1 format, you must specify the read-compatible special attribute indicator (in the tape configuration database) or use LABEL=(,,,IN) on the DD statement of JCL to enable the 3592 Model E06 drive to be considered eligible for an EFMT1 request.</li> <li>3. As appropriate, install the Encryption Key Manager (EKM) and set up the key store it will use.</li> <li>4. As appropriate, create the data classes or the DD statements (or use Encryption Key Manager defaults) to specify the key labels and their encoding mechanism (label or hash).</li> <li>5. For in-band key management, update (as appropriate) the IOS PARMLIB member (IECIOSxx) using the EKM command. Also create a z/OS UNIX segment for the IOS address space.</li> <li>6. Upgrade 3592 Model J1A and 3592 Model E05 microcode to enable the library drives to recognize and enable the EFMT3 or EEFMT3 formatted cartridges to be relabelled/reused. Also, ensure that VOLNSNS=YES is in the DEVSUPxx member of PARMLIB.</li> <li>7. Make the required installation exit changes.</li> <li>8. Define or alter existing data class constructs as appropriate, to specify the EFMT3 or EEFMT3 recording technology, MEDIA5, MEDIA6, MEDIA7, MEDIA8, MEDIA9, or MEDIA10 media type, and the performance attributes (performance scaling or performance segmentation available with MEDIA5 and MEDIA9 tape cartridges only).</li> <li>9. Define or alter existing storage group constructs to include libraries with the new TS1130 tape drives devices.</li> <li>10. Update ACS routines to direct allocation to the TS1130 tape drives device as requested.</li> <li>11. Validate and activate any new or modified SMS configuration.</li> <li>12. Make any needed changes to the HCD to define the new devices.</li> <li>13. To define the partitioning category code for MEDIA5 MEDIA6, MEDIA7, or MEDIA8, MEDIA9, or MEDIA10 tape cartridges, specify the appropriate parameter of the DEVSUPxx parmlib member.</li> <li>14. IPL the system.</li> </ol>	Required	<ul style="list-style-type: none"> <li>• <i>z/OS DFSMS OAM Planning, Installation, and Storage Administration Guide for Tape Libraries</i></li> <li>• <i>z/OS HCD User's Guide</i></li> <li>• <i>z/OS DFSMSdfp Storage Administration</i></li> </ul>

System-Level Tasks	Condition	Procedure Reference
<p data-bbox="188 216 456 243"><i>OAM object tape environment</i></p> <p data-bbox="188 268 821 342">The migration steps that you must take in tape environments that use OAM objects vary depending upon the type of environment that is installed:</p> <ol style="list-style-type: none"> <li data-bbox="188 352 821 636">1. If you install the new TS1130 tape drives devices in an OAMplex: <ol style="list-style-type: none"> <li data-bbox="224 415 821 489">a. Make the new TS1130 tape drives devices available to all instances of OAM where the full support software is installed.</li> <li data-bbox="224 499 630 527">b. Install coexistence PTFs as appropriate.</li> <li data-bbox="224 537 821 636">c. Consider setting DSNWITHSGNAME in the SETOAM statement in the CBROAMxx PARMLIB member. Review your ACS routines if appending the storage group name to OAM data set names (DSNWITHSGNAME).</li> </ol> </li> <li data-bbox="188 646 821 909">2. If you install the new TS1130 tape drives devices in an IBM tape library: <ol style="list-style-type: none"> <li data-bbox="224 709 800 762">a. Follow the migration steps listed for an IBM tape library environment.</li> <li data-bbox="224 772 821 846">b. Define the new data classes in STORAGEEGROUP statements in the CBROAMxx member of PARMLIB for the object storage groups that are to use the new devices.</li> <li data-bbox="224 856 781 909">c. Make the needed changes to ACS routines for ALLOC, STORE, or CTRANS environments.</li> </ol> </li> <li data-bbox="188 919 821 1539">3. If you install the new TS1130 tape drives devices in a stand-alone environment: <ol style="list-style-type: none"> <li data-bbox="224 982 740 1035">a. Follow the migration steps listed for a stand-alone environment.</li> <li data-bbox="224 1045 821 1245">b. Add new device esoteric unit names or generic unit names to STORAGEEGROUP statements in the CBROAMxx member of PARMLIB for the object storage groups that are to use the new EFMT3 or EEFMT3 recording technologies. The esoteric or generic unit name must consist of TS1130 tape drives exclusively because the EFMT3 and EEFMT3 recording technologies are not compatible with the other 3592 drives.</li> <li data-bbox="224 1255 821 1350">c. Consider setting DSNWITHSGNAME in the SETOAM statement in the CBROAMxx PARMLIB member. Review your ACS routines if appending the storage group name to OAM data set names (DSNWITHSGNAME).</li> <li data-bbox="224 1360 781 1413">d. Make the needed changes to ACS routines for ALLOC, STORE and CTRANS environments.</li> <li data-bbox="224 1423 821 1539">e. Define the new data classes in STORAGEEGROUP statements in the CBROAMxx member of PARMLIB for the object storage groups that are to use the new EFMT3 or EEFMT3 recording technologies.</li> </ol> </li> <li data-bbox="188 1549 821 1799">4. In an OAM Object Tape environment, any coexistence or full support systems must also have the new overflow-related columns added to the TAPEVOL table in the Optical Configuration Database (OCDB). Only one system in an OAMplex needs to run CBRSMKBO sample JCL to add the new TAPEVOL columns, but all systems in the OAMplex need to run CBRPBIND. Adding the new TAPEVOL columns and running CBRPBIND is needed with the installation of the new PTFs regardless of whether the new TS1130 tape drives are being used.</li> </ol>	Required	<i>z/OS DFSMS OAM Planning, Installation, and Storage Administration Guide for Object Support</i>

<b>System-Level Tasks</b>	<b>Condition</b>	<b>Procedure Reference</b>
<p><i>DFSMSHsm tape environment</i></p> <p>DFSMSHsm allows the specification of tape unit names using either generic or esoteric names. Installations that have a mixture of non-SMS-managed 3590 devices defined under the 3590-1 generic name, need to perform these steps:</p> <ol style="list-style-type: none"> <li>1. Define a unique esoteric for each recording technology.</li> <li>2. Use the SETSYS USERUNITTABLE command to define these esoteric names to DFSMSHsm. This also applies to mixed devices in the 3490 generic. Installations that use SMS-managed tape devices or have a single 3590-1 recording technology, do not need to define an esoteric for those devices.</li> </ol>	Required	<ul style="list-style-type: none"> <li>• <i>z/OS DFSMSHsm Implementation and Customization Guide</i></li> <li>• <i>z/OS DFSMSHsm Storage Administration</i></li> </ul>
<p><i>Setting up DFSMSHsm to use WORM output tapes for ABACKUP</i></p> <p>In a SMS tape environment, and optionally in a non-SMS tape environment, the SMS data class construct can be used to select WORM tapes for ABACKUP processing. The output data set prefix specified in the aggregate group definition can be used by the ACS routines to select a WORM data class. Set up the ACS routine and the output data set name to uniquely identify the ABARS output files that must go to WORM tape.</p> <p>In a non-SMS tape environment, the default allows tape pooling to determine if ABARS data sets go to WORM or R/W media. Optionally, if the DEVSUP:xx parameter, ENFORCE_DC_MEDIA=ALLMEDIATY or ENFORCE_DC_MEDIA=MEDIA5PLUS, is used, then the data class must request the appropriate media type for it to be successfully mounted.</p>	Required	<ul style="list-style-type: none"> <li>• <i>z/OS DFSMSHsm Implementation and Customization Guide</i></li> <li>• <i>z/OS DFSMSHsm Storage Administration</i></li> </ul>
<b>Application-level tasks</b>	<b>Condition</b>	<b>Procedure reference</b>
<p>For programs that use dynamic allocation and cannot take advantage of predefined data class definitions, set the PARM for the DALINCHG text unit key in DALINCHG to specify the media type and recording technology for system-managed tape library allocations.</p>	Optional	<i>z/OS MVS Programming: Authorized Assembler Services Guide</i>



---

## Chapter 16. Access method services (AMS) modifications

This topic describes changes to the access method services (AMS) commands to support the new subparameters, EFMT3 and EEFMT3 for the parameter RECORDING. The changed commands are:

- “ALTER VOLUMEENTRY” on page 286
- “CREATE VOLUMEENTRY” on page 292
- “DCOLLECT” on page 295
- “LISTCAT” on page 297

**Attention:** Use these AMS commands only to recover from tape volume catalog errors. Because AMS cannot change the library manager inventory in an automated tape library, use ISMF for normal tape library alter functions.

**Related reading:**

For explanations of all the parameters used with the AMS commands and additional examples, refer to *z/OS DFSMS Access Method Services Commands*.

---

### Enterprise format 3 (EFMT3) and enterprise encrypted format 3 (EEFMT3)

Enterprise format 3 (EFMT3) and enterprise encrypted format 3 (EEFMT3) are new recording technologies used by the TS1130 tape drive. EFMT3 is the non-encrypted recording format and is the default recording format for the TS1130. EEFMT3 is used to specify that the data on the tape is recorded in the encryption format.

---

### EFMT3 and EEFMT3 support for ALTER VOLUMEENTRY

Use the AMS ALTER VOLUMEENTRY command to modify the attributes for an existing tape volume entry.

The ALTER VOLUMEENTRY command allows recording fields in the volume records of a tape library to be altered with the following rules:

- EFMT3 subparameter indicates READ/WRITE on an EFMT3 track device.
- EEFMT3 subparameter indicates READ/WRITE on an EEFMT3 track device.
- EFMT3 subparameter of RECORDING is only allowed with media types MEDIA5, MEDIA6, MEDIA7, MEDIA8, MEDIA9, or MEDIA10. The use of MEDIA1 through MEDIA4 will produce an IDC3266I error message being generated twice. Once for EFMT3 and once for the media type. The generation of the two IDC3226I error messages indicates an incompatibility between the EEFMT3 subparameter and the media type displayed.
- EEFMT3 subparameter of RECORDING is only allowed with media types MEDIA5, MEDIA6, MEDIA7, MEDIA8, MEDIA9 or MEDIA10. The use of MEDIA1 through MEDIA4 produces an IDC3226I error message being generated twice, once for EEFMT3 and once for the media type. The generation of the two IDC3226I error messages indicates an incompatibility between the EEFMT3 subparameter and the media type displayed.

## EFMT3 and EEFMT3 subparameter for ALTER VOLUMEENTRY

RECORDING(18TRACK | 36TRACK | 128TRACK | 256TRACK | 384TRACK | EFMT1 | EFMT2 | EEFMT2 | EFMT3 | EEFMT3 | UNKNOWN)

This shows the EEFMT3 subparameter associated with the RECORDING parameter for ALTER VOLUMEENTRY

---

## EFMT3 and EEFMT3 support for CREATE VOLUMEENTRY

The CREATE VOLUMEENTRY command allows the recording field in the volume records of a tape library to be created with subparameters of EFMT3 or EEFMT3 with the following rules:

- EFMT3 subparameter indicates READ/WRITE on an EFMT3 track device.
- EEFMT3 subparameter indicates READ/WRITE on an EEFMT3 device.
- EFMT3 is only allowed with media types MEDIA5, MEDIA6, MEDIA7, MEDIA8, MEDIA9, or MEDIA10. Any use of MEDIA1 through MEDIA4 will produce an IDC3226I error message being displayed twice. Once for EFMT3 and once for the media in question. The double display indicates an incompatibility between the EFMT3 subparameter and the media type displayed.
- EEFMT3 is only allowed with media types MEDIA5, MEDIA6, MEDIA7, MEDIA8, MEDIA9, or MEDIA10. Any use of MEDIA1 through MEDIA4 produces an IDC3226I error message being displayed twice. Once for EEFMT3 and once for the media in question. The double display indicates an incompatibility between the EEFMT3 subparameter and the media type displayed.
- If MEDIA5, MEDIA6, MEDIA7, or MEDIA8 are specified and RECORDING is not specified, default to EFMT1 for RECORDING value.
- If MEDIA9 or MEDIA10 are specified and RECORDING is not specified, default to EFMT2 for RECORDING value.

## EFMT3 and EEFMT3 subparameters for CREATE VOLUMEENTRY

RECORDING(18TRACK | 36TRACK | 128TRACK | 256TRACK | 384TRACK | EFMT1 | EFMT2 | EEFMT2 | EFMT3 | EEFMT3 | UNKNOWN)

This shows the EEFMT3 subparameter associated with the RECORDING parameter for CREATE VOLUMEENTRY.

---

## EFMT3 and EEFMT3 Support for DCOLLECT

The DCOLLECT command has values added to its definitions for DDRECTE to allow the constants DDCEFMT3 for the EFMT3 recording technology and DDCEEFM3 for the EEFMT3 recording technology.

## EFMT3 and EEFMT3 subparameter for DCOLLECT

DDRECTE(DDCRTNUL | DDC18TRK | DDC36TRK | DDC128TK | DDC256TK | DDC384TK | DDCEFMT1 | DDCEFMT2 | DDCEEFM2 | DDCEFMT3 | DDCEEFM3)

DDCEFMT3

The recording technology is EFMT3. The constant value is 9.

DDCEEFM3

The recording technology is EEFMT3. The constant value is 10.

## EFMT3 and EEFMT3 support for LISTCAT

The LISTCAT command is enhanced to display the new values associated with the RECORDING parameter for VOLUME entries.

### EFMT3 and EEFMT3 subparameters in List tape volume entries sample output

```
LISTCAT -
  VOLUMEENTRIES
  ALL
IDCAM5  SYSTEM SERVICES                TIME: 11:29:12          09/02/05    PAGE    2
      LISTING FROM CATALOG -- SYS1.VOLCAT.V0
VOLUME-ENTRY----V0A2991
  DATA-VOLUME
  LIBRARY-----ATLIB02      RECORDING-----EEFMT3      ERROR-STATUS----NOERROR      CREATION-DATE-2008-04-02
                                MEDIA-TYPE-----MEDIAx      USE-ATTRIBUTE----SCRATCH      ENT-EJ-DATE----- (NULL)
  STORAGE-GROUP---*SCRCH+    COMPACTION----- (YES)      WRITE-PROTECTED--- (NULL)      LAST-MOUNTED----- (NULL)
  CHECKPOINT----- (NULL)    SP-ATTRIBUTE-----NONE      SHELF-LOC----- (NULL)      LAST-WRITTEN----- (NULL)
  LOCATION-----LIBRARY      OWNER----- (NULL)      EXPIRATION----- (NULL)
IDCAM5  SYSTEM SERVICES                TIME: 11:29:12          09/02/08    PAGE    3
      LISTING FROM CATALOG -- SYS1.VOLCAT.VGENERAL
      THE NUMBER OF ENTRIES PROCESSED WAS:
          AIX -----0
          ALIAS -----0
          CLUSTER -----0
          DATA -----0
          GDG -----0
          INDEX -----0
          NONVSAM -----0
          PAGESPACE -----0
          PATH -----0
          SPACE -----0
          USERCATALOG -----0
          TAPELIBRARY -----0
          TAPEVOLUME -----1
          TOTAL -----1
      THE NUMBER OF PROTECTED ENTRIES SUPPRESSED WAS 0
IDC0001I FUNCTION COMPLETED, HIGHEST CONDITION CODE WAS 0
IDCAM5  SYSTEM SERVICES                TIME: 11:29:12          09/02/08    PAGE    4
IDC0002I IDCAMS PROCESSING COMPLETE. MAXIMUM CONDITION CODE WAS 0
```

**Note:** MEDIAx represents either MEDIA5, MEDIA6, MEDIA7, MEDIA8, MEDIA9, or MEDIA10.



---

## Chapter 17. Tape drive and tape volume allocation modifications for 3592 Model E06

Changes made to device support, storage management subsystem (SMS), and Multiple Virtual Storage (MVS) device allocation enable you to allocate the tape drives and tape volumes. Within an IBM tape library environment, your system can fully recognize all supported media types and recording technologies.

---

### Device support modifications

z/OS DFSMS device support provides hardware device-specific code, which allows tape drives, tape volumes, and DASD to interface with z/OS DFSMS. Specifically, it provides:

- The interfacing exits to the input/output supervisor (IOS) and EXCP device support code
- Error recovery procedure routines
- Services to acquire and log statistical and error data
- Services to acquire and display device states
- Utilities for functions like initializing tapes

You can use the MVS DEVSERV command to request basic status information on a device, a group of devices, or storage control units. You can use the QTAPE parameter of the DEVSERV command to display tape device information. Use DEVSERV QTAPE to display the real device type and the emulated device type.

With the DEVSERV QTAPE MED (medium) option, you can display information for the device type, media type, and cartridge volume serial number.

The syntax of the DEVSERV QTAPE command with the MED option is as follows:

```
DS QT,xxx,MED,nnn
```

*xxx*

Represents a three-digit or a four-digit device number in hexadecimal format.

*nnn*

Stands for the number of devices, starting at the address *xxx*, for which the DEVSERV command displays the MED information. The value *nnn* is optional and can be any decimal number from 1 to 256, with 1 as the default value.

DEVSERV QTAPE will display '3592E06' for the real device type, where E06 is the drive model, if the underlying physical device is a 3592 Model E06 (TS1130). If the MEDIUM option is specified for DEVSERV QTAPE command, the real device type will be displayed as '3592-3E'.

Figure 6 on page 118 shows the output of DS QT,960 when a TS1130 (3592 Model E06) tape drive emulates a 3590 Model B1x tape drive.

```

11.20.46 SYSTEM1          DS QT,960
11.20.46 SYSTEM1          IEE459I 11.20.46 DEVSERV QTAPE 760
UNIT DTYPE  DSTATUS CUTYPE  DEVTYPE  CU-SERIAL  DEV-SERIAL ACL LIBID
0960 3590   ON-RDY  3592J70 3592E06* 0178-00030 0178-00030

```

Figure 6. DS QT,960 output

Figure 7 shows the output of DS QT,960,MED when a TS1130 (3592 Model E06) tape drive emulates a 3590 Model B1x tape drive.

```

11.21.21 SYSTEM1          ds qt,960,MED
11.21.21 SYSTEM1          IEE459I 11.21.21 DEVSERV QTAPE 763
UNIT RDTYPE  EDTYPE  EXVLSR  INVLSR  RMEDIA  EMEDIA          WWID
0960 3592-3E 3590-1      1P0694  9      3

```

Figure 7. DS QT,960,MED output

A bit DFVTJAG3 is added to the IHADFVT mapping macro that maps the data facilities vector table. When this bit is set, it indicates that all of the software support for the 3592 Model E06 (TS1130) drive is on the system. This bit is set by the enabling module IECTEPTF, if it is installed.

The IECUCBCX mapping macro is changed to support the TS1130:

- The new EPI value is X'14' - REALJAG3\_EMUL3590
- A new data key shred support bit is defined in flag byte 7 (UCBCXFL7) UCBCX\_SHRED EQU X'40'

The tape initialization (INITT) and rekeying (REKEY) functions of the IEHINITT Utility now allow an alphanumeric volsr to be specified for SER keyword when NUMBTAPE is specified. (Previously, if more than one tape was specified in NUMBTAPE, the volume serial number of the first tape had to be all numeric.) The volume serial number can now be specified as alphanumeric, with the requirement that the last one to six characters be numeric. z/OS will increment the numeric suffix of the volume serial number by one for each additional tape. For example, VOL100 is incremented to VOL101, V19999 is incremented to V20000, and 123456 is incremented to 123457.

The following rules apply when the value specified for NUMBTAPE is greater than 1:

- When the numeric suffix exceeds its incremental limit, IEHINITT will process up to the largest number allowed for the numeric suffix and issue a warning message. For example:

```
SER=TOM991, NUMBTAPE=10
```

In this example, the maximum value of the numeric suffix 991 is 999, therefore, up to nine tapes are processed. The tenth tape is ignored and the following new message is issued:

```
IEH641I THE NUMERIC SUFFIX OF THE SERIAL NUMBER EXCEEDED POSSIBLE MAXIMUM VALUE -
THE LAST VOLUME PROCESSED WAS 'volser'
```

In this example, the “volser” indicated would be TOM999. An exception to this rule is when the serial number is all numeric and an overflow occurs, the serial number is still allowed to wrap around (Serial number 999999 is incremented to 000000).

- When the last character is alphabetic, the following updated message will be issued.

Existing message:  
 IEH623E INVALID SERIAL NUMBER. SERIAL NUMBER MUST BE ALL NUMERIC WHEN VALUE SPECIFIED FOR NUMBTAPE IS GREATER THAN 1

Changed message:  
 IEH623E INVALID SERIAL NUMBER. AT LEAST ONE OR MORE RIGHTMOST CHARACTERS MUST BE NUMERIC WHEN NUMBTAPE IS GREATER THAN 1

The following parameter keywords for IEHINITT have been updated:

**SER=serial number**

specifies the volume serial number of the first or only tape to be labeled. Specify up to six characters. For IBM standard labeled (SL) tapes, the serial number cannot contain blanks, commas, apostrophes, equal signs, or special characters other than periods, hyphens, dollar signs, pound signs, and at signs ('@'). ISO/ANSI labeled tapes (AL) may contain any valid ISO/ANSI 'a' type character as described under the OWNER keyword. However, if any non-alphanumeric character (including a period or a hyphen) is present, delimiting apostrophes must be included. You cannot use a blank as the first character in a volume serial number. When NUMBTAPE keyword is specified with a value greater than 1, the volume serial number must be all numeric or the last one to six characters of the volume serial number must be numeric.

When a volume serial number is all numeric, it is increased by one for each additional tape (Note: Serial number 999999 is increased to 000000).

When a volume serial number is alphanumeric, only the numeric suffix is increased by one for each additional tape (Serial number VOL100 is increased to VOL101, T19999 is increased to T20000, and 100A01 is increased to 100A02). In the case where the numeric suffix exceeds its incremental maximum value, IEHINITT processes up to the largest serial number allowed for the numeric suffix and the warning message IEH641I is issued. (For example, SER=TOM991, NUMBTAPE=10 – Up to nine volumes are processed and the last volume is TOM999.)

**NUMBTAPE={n|1}**

specifies the number of tapes to be processed according to the specifications made in this control statement. The value n represents a number from 1 to 255. If more than one tape is specified, the volume serial number of the first tape must be all numeric or the last one to six characters must be numeric.

The DDR Swap Exit handles swaps involving the 3592 Model E06 drive and the new recording formats EFMT3 and EEFMT3. Appropriate rules are also put in place for handling a lower technology EFMT1, EFMT2, or EEFMT2 request on a 3592 Model E06 to a 3592 Model J or E05 (as appropriate and as consistent with past 3592 support). Table 17 shows a summary of what swaps are allowed.

Table 17. Format swaps allowed for TS1130

Format	From Device	Allowed to device	Notes
EFMT1	3592-J 3592-2 3592-2E	3592-J 3592-2 3592-2E	Swap to a 3592-3E not allowed
EFMT1	3592-3E	3592-J 3592-2 3592-2E 3592-3E	Swap allowed from 3592-3E to any 3592 type device
EFMT1	3592-3E and Write attempted RC-RQC=x'2420'	3592-J 3592-2 3592-2E 3592-3E	

Table 17. Format swaps allowed for TS1130 (continued)

Format	From Device	Allowed to device	Notes
EFMT2	3592-2 3592-2E 3592-3E	3592-2 3592-2E 3592-3E	Swap allowed to a 3592-2, 3592-2E or 3592-3E
EEFMT2	3592-2E 3592-3E	3592-2E 3592-3E	Swap allowed to an encryption-capable drive
EFMT3 EEFMT3	3592-3E	3592-3E	Swap allowed only to 3592-3E

## IOS000I Message with Encryption Failure

If an encryption-related key exchange between the drive and the key manager fails, an IOS000I message is issued indicating that an encryption failure has occurred:

```
IOS000I 07C2,7D,IOE,06,0600,,**,J1G150,ENCREADA 594
804008C022402751 0806FF0000131415 0017181900000092 2004E82061C42111
ENCRYPTION FAILURE
CU=08 DRIVE=131415 EKM=171819
```

**Note:** The preceding values for CU, DRIVE, and EKM generically represent the byte positions in sense data where the errors would be reported .

The control unit (CU), DRIVE, and Encryption Key Manager (EKM) error codes are from sense bytes 08, 13-15, and 17-19, respectively. For example:

```
IOS000I 0BD0,60,IOE,01,0E00,,**,JJC046,ATNCMP1
804C08C022402751 0001FF0000000000 0005EE3100000092 2004E82061BA2111
ENCRYPTION FAILURE
CU=00 DRIVE=000000 EKM=05EE31
```

In this example, the error was reported by the Encryption Key Manager (EKM).

For an EKM failure, refer to the Problem Determination section of the *IBM System Storage Tape Encryption Key Manager, Introduction, Planning, and User's Guide*, GA76-0418. When looking up the EKM failure, use the last two bytes of the error code (for example, EE31 in the example above).

For a control unit failure, refer to the *IBM System Storage TS1120/TS1130 Tape Drive and Controller Operator Guide 3592 Models J1A, E05, E06, EU6, J70 and C06*, GA32-0556. Table 30 on page 211 contains error codes for control unit failures.

Table 18. Error codes for control unit failures

Error Code	Description	Recovery Action
00	Not a control unit reported failure	Refer to the EKM and drive error codes reported in the IOS000I message for failure information.
01	The EKM was not available for an out-of-band key exchange.	Verify the EKM that the control unit is configured to use and also verify the state of that EKM. However, if the intent was to use in-band key management, use the EKM subcommand of the IECIOSxx PARMLIB member or the SETIOS command to specify your key manager(s).



Table 18. Error codes for control unit failures (continued)

Error Code	Description	Recovery Action
02	Timeout for an out-of-band key exchange	The EKM may have gone down mid-sequence, or there may be a network problem. Verify the state of the EKM and the TCP/IP network. However, if the intent was to use in-band key management, use the EKM subcommand of the IECIOSxx PARMLIB member or the SETIOS command to specify your key manager(s).
03	An in-band key exchange was canceled by the host.	Check for an IOS628E message for further information as to why the in-band proxy may have canceled the key exchange. For additional information on these error codes, see <i>z/OS UNIX System Services Messages and Codes</i> .

For more detailed information about the drive-reported conditions, and also about the EKM-reported conditions, see the Problem Determination section of the *IBM System Storage TS3500 Tape Library Operator Guide*, GA32-0560.

If there are multiple error codes reported, start with the EKM error code.

In addition, any system-managed tape library scratch tape that receives the IOS000I ENCRYPTION FAILURE message along with an IEC512 I/O ERR, remains in a scratch status, but is updated in the Tape Control Data Base (TCDB) with a VOLUME ERROR STATUS of I/O ERROR. This causes it to be placed in the software error category, and the tape is unusable until the I/O ERROR condition is cleared through manual intervention (for example, use ISMF volume ALTER from scratch. Scratch moves the volume from the software error category back to the scratch category). Periodically, use the DISPLAY SMS,LIBRARY command with DETAIL to display the number of scratch volumes in the software error category.

---

## SMS modifications

SMS automates and centralizes storage management. It automatically assigns service requirements and attributes to data when that data is created. SMS configuration services validate, for example, the recording technology value that ISMF specifies in data class definitions.

SMS will support a new recording technology EFMT3 and EEFMT3.

In an IBM tape library environment (automated or manual), use ISMF to specify the new recording formats (EFMT3 and EEFMT3) and for media interchange (EFMT2 and EEFMT2). Also remember that even though the TS1130 (3592 Model E06) tape drive can read in the EFMT1 format, it cannot write in that format.

The recording technology attribute and the performance scaling or performance segmentation options can also be specified and used outside of the system-managed tape library environment.

In support of the TS1130 tape drives, SMS configuration services are updated to validate the recording technology values EFMT3 and EEFMT3.

## In Data Class

With SMS, the system obtains information about the attributes of a data set from the data class for the data set.

When using encryption, any data set attributes you specify on these DD parameters override the corresponding attributes in the data class for the data set:

- KEYLABL1 (key label 1)
- KEYENCD1 (encoding for key label 1)
- KEYLABL2 (key label 2)
- KEYENCD2 (encoding for key label 2)

## Overriding Attributes Defined in the Data Class

For a new data set, you can override the data class attributes defined in the data class for the data set by coding one or more of these DD parameters:

- KEYLABL1 (key label 1)
- KEYENCD1 (encoding for key label 1)
- KEYLABL2 (key label 2)
- KEYENCD2 (encoding for key label 2)

---

## MVS device allocation modifications

MVS device allocation helps prioritize and select tape drives to meet the needs of application programs or system functions. Batch (JCL) or dynamic (SVC99) allocation makes these device needs known to MVS device allocation. MVS device allocation selects the appropriate devices and serializes them for the requester to use. It can also request that appropriate volumes be mounted on the allocated devices. It accomplishes these tasks by interfacing with SMS, DEVSERV, OAM, MSGDISP, and other system components.

MVS device allocation currently supports multiple types of tape devices. Within an IBM tape library environment, MVS device allocation considers media types and recording technologies when allocating tape drives and tape volumes. For the TS1130 tape drive, the dynamic allocation (SVC 99) volume interchange text unit (DALINCHG) allows you to specify EFMT2, EEFMT2, EFMT3, or EEFMT3 for the recording technology and MEDIA5, MEDIA6, MEDIA7, MEDIA8, MEDIA9, and MEDIA10 for the media type.

See Table 19 for DALINCHG parameter values appropriate for the TS1130.

*Table 19. Dynamic allocation (DALINCHG) parameter values for tape cartridge media types*

Parameter Value	Media Type	Recording Technology
A5	MEDIA5	EEFMT3
95	MEDIA5	EFMT3
85	MEDIA5	EEFMT2
75	MEDIA5	EFMT2
05	MEDIA5	No format

Table 19. Dynamic allocation (DALINCHG) parameter values for tape cartridge media types (continued)

Parameter Value	Media Type	Recording Technology
A6	MEDIA6	EEFMT3
96	MEDIA6	EFMT3
86	MEDIA6	EEFMT2
76	MEDIA6	EFMT2
06	MEDIA6	No format
A7	MEDIA7	EEFMT3
97	MEDIA7	EFMT3
87	MEDIA7	EEFMT2
77	MEDIA7	EFMT2
07	MEDIA7	No format
A8	MEDIA8	EEFMT3
98	MEDIA8	EFMT3
88	MEDIA8	EEFMT2
78	MEDIA8	EFMT2
08	MEDIA8	No format
A9	MEDIA9	EEFMT3
99	MEDIA9	EFMT3
89	MEDIA9	EEFMT2
79	MEDIA9	EFMT2
09	MEDIA9	No format
AA	MEDIA10	EEFMT3
9A	MEDIA10	EFMT3
8A	MEDIA10	EEFMT2
7A	MEDIA10	EFMT2
0A	MEDIA10	No format

**Related reading:**

- See *z/OS MVS System Commands* for more information on the DEVSERV QTAPE command.
- See *z/OS MVS Programming: Authorized Assembler Services Guide* for more information about the DALINCHG parameter.
- See *z/OS DFSMS Installation Exits* for more information about the IECUCBCX mapping macro.

---

## JCL DD Statement Parameters and Equivalent Text Units for TS1130

The JCL DD statement parameters and equivalent text units for TS1130 are unchanged from those for the TS1120. See “JCL DD statement parameters and equivalent text units for TS1120” on page 215.

---

## DSNAME Allocation Text Units for TS1130

The DSNAME allocation text units for TS1130 are unchanged from those for the TS1120. See “DSNAME Allocation Text Units for TS1120” on page 215.

---

## Verb Code 01 - Non-JCL Dynamic Allocation Functions for TS1130

### Volume Interchange Specification - Key = '006F'

DALINCHG specifies the media type and track recording technique required for system-managed tape library allocation. Whenever possible, IBM suggests that you use an installation-defined DATACLAS construct name to control cartridge media type and track recording technique. Use this key only when it is not possible to use a pre-defined DATACLAS construct because of the dynamic nature of the program and because the program must control the media type and track recording technique. Contact your storage administrator before using this key.

**Note:** To specify DALINCHG, your program must be APF-authorized, in supervisor state, or running in PSW key 0-7. The specification of DALINCHG will be ignored if a non-system-managed tape volume is allocated.

When you code this key, # and LEN must be one. These PARM values are new for the TS1130:

- 95 Enterprise Cartridge Tape 3592 requested; Enterprise Format 3 recording technology requested.
- 96 Enterprise WORM Cartridge Tape 3592 requested; Enterprise Format 3 recording technology requested.
- 97 Enterprise Economy Cartridge Tape 3592 requested; Enterprise Format 3 recording technology requested.
- 98 Enterprise Economy WORM Cartridge Tape 3592 requested; Enterprise Format 3 recording technology requested.
- 99 Enterprise Extended Cartridge Tape 3592 requested; Enterprise Format 3 recording technology requested.
- 9A Enterprise Extended WORM Cartridge Tape 3592 requested; Enterprise Format 3 recording technology requested.
- A5 Enterprise Cartridge Tape 3592 requested; Enterprise Encrypted Format 3 recording technology requested.
- A6 Enterprise WORM Cartridge Tape 3592 requested; Enterprise Encrypted Format 3 recording technology requested.
- A7 Enterprise Economy Cartridge Tape 3592 requested; Enterprise Encrypted Format 3 recording technology requested.
- A8 Enterprise Economy WORM Cartridge Tape 3592 requested; Enterprise Encrypted Format 3 recording technology requested.
- A9 Enterprise Extended Cartridge Tape 3592 requested; Enterprise Encrypted Format 3 recording technology requested.
- AA Enterprise Extended WORM Cartridge Tape 3592 requested; Enterprise Encrypted Format 3 recording technology requested.

---

## Chapter 18. ISMF modifications for TS1130 tape drive

In ISMF, these applications are modified to support the two new recording formats EFMT3 and EEFMT3:

- Data class define and alter panels
- Mountable tape volume list panel

### Related reading:

- See *z/OS DFSMS OAM Planning, Installation, and Storage Administration Guide for Tape Libraries* for additional information on the ISMF tape library management application.
- See *z/OS DFSMSdfp Storage Administration* for additional information about data classes and the ISMF data class panels.

---

### Data class define and alter panels

A data class is a set of data set allocation attributes and associated values. You can define, alter, display, and list a data class by using the ISMF data class panels. In addition to the previously available values, you can now specify the E3 value for the recording technology attribute EFMT3, and the EE3 value for the recording technology attribute EEFMT3 on the data class define/alter panel. For EEFMT3 (or the media interchange recording format EEFMT2), an existing panel is displayed for the user to enter the Key Labels and Encoding Mechanisms. The existing Performance Scaling and Performance Segmentation data class options, applicable with MEDIA5 and MEDIA9, can also be used with the new recording formats EFMT3 and EEFMT3.

---

### Mountable tape volume list panel

On the mountable tape volume list, the value EFMT3 and EEFMT3 can appear in column 9, RECORDING TECHNOLOGY.



---

## Chapter 19. OCE modifications for TS1130 tape drive

The z/OS DFSMS Open/Close/End-of-Volume (OCE) component is a set of system routines that builds the control block structure that connects the application, access method, and the operating system. OCE modifications for the TS1130 tape drive 3592 Model E06 include support for the EFMT3 and EEFMT3 recording technologies.

### Related reading:

- See *z/OS DFSMS Using Data Sets* and *z/OS DFSMS Using Magnetic Tapes* for additional information about the OCE routines.
- See *z/OS DFSMS Installation Exits* for more information on OCE installation exit parameter lists.
- See *z/OS DFSMS OAM Planning, Installation, and Storage Administration Guide for Tape Libraries* for more information on tape volume records.

---

### Overview

Two new recording formats, EFMT3 and EEFMT3, are supported by the TS1130 tape drive (3592 Model E06). The new recording formats are higher density formats that increase cartridge capacities. For media interchange, the TS1130 drive is downward write compatible with EFMT2 and EEFMT2, and downward read compatible with EFMT1, EFMT2, and EEFMT2. EFMT3 is the default recording technology. The drive also supports the existing MEDIA5, MEDIA6, MEDIA7, MEDIA8, MEDIA9, and MEDIA10. The TS1130 tape drive 3592 Model E06 is only supported in 3590-1 Model B emulation.

---

### SMS Managed Tape

An SMS managed cartridge Tape Volume Record (TVR) is updated by OPEN and EOVS with the new recording technology when opened for output to the first file (beginning of tape) on a 3592 Model E06 drive.

---

### Recording Technology Conflict

OPEN and EOVS resolve the incompatible track conflict when an EFMT3 or EEFMT3 formatted cartridge is mounted on 3592 Model J1A or on 3592 Model E05 drive during OPEN OUTPUT file sequence 1. The load point label structure is rewritten at the drive capable recording technology using the existing volume serial number obtained from the drive sense data.

---

### Multiple Recording Format Capability

When a data set is opened for OUTPUT, file sequence 1, DISP=NEW, OPEN processing will be enhanced to recognize the data class recording technology specification and will explicitly direct the 3592 Model E06 to record in the appropriate recording format. By default, the 3592 Model E06 will record in the non-encrypted up-level format EFMT3 unless explicitly changed to record in another format. However, to account for the default setting being changed at the drive, OPEN processing will always send down the recording format specified in data class, and if a recording format is not explicitly specified, EFMT3 will be used.

When writing from BOT (file sequence 1, DISP=OLD or DISP=SHR), since this processing does not go through the data class ACS routine, OPEN processing needs to determine if encryption had previously been used (EEFMT2 or EEFMT3) and ensure that encryption is requested for this next usage of the tape. So if the previous usage of the tape was encrypted, OPEN will explicitly set the new encryption format (EEFMT3) and will obtain and pass the volume's existing key management-related information to the drive (key label and encoding mechanism). This is similar to the support that was put in place with the 3592 Model E05 encryption support in handing the encryption format EEFMT2. This is also consistent with today's 3592 Model E05 drives where on reuse, if encryption was not used, the highest non-encryption recording format is specified.

---

## Cartridge Reuse with DISP=OLDISHR

Cartridge reuse occurs when writing from BOT file sequence 1 with a disposition of DISP=OLD or DISP=SHR. When the mounted cartridge is encrypted, OPEN processing will set the recording technology to EEFMT3 and pass the volume's existing key labels and encoding mechanism to the drive. Additionally, when the mounted MEDIA5 or MEDIA9 cartridge is Performance Scaled or Performance Segmented OPEN will ensure the cartridge maintains the same characteristic on reuse.

---

## OCE Tape Installation Exits

The IFGTPE macro maps the tape log data. Table 34 on page 223 describes the IFGTPE fields for mapping the installation exit main parameter list.

*Table 20. IFGTPE fields for the installation exit main parameter list*

Field name	Length and type	Description
TEPMRECTK	Fixed(8)	Recording technology of the mounted volume in binary.  9 - EFMT3  10 - EEFMT3

---

## Multiple Recording Format Capability

For both system managed and standalone environments, during OPEN OUTPUT, file sequence 1, DISP=NEW, OPEN will retrieve the DATACLASS to determine which recording technology (EFMT3 or EEFMT3 or interchange formats EFMT2 or EEFMT2) should be used. For the prevailing recording format, OPEN will issue a command to enable it from load point. In fact, whenever the tape is to be written from load point, OPEN OUTPUT and EOV will issue a command for the existing or prevailing recording technology. By default EFMT3 is requested.

---

## IEZDEB (second DEB extension)

OPEN processing will set new IEZDEB bit DEB2XEE3 if the cartridge is encrypted in the EEFMT3 format. OPEN will also set new bit DEB2XENC if the cartridge is encrypted (in either EEFMT2 or EEFMT3 encryption format). OPEN will set existing IEZDEB bit DEB2XEEF if the cartridge is encrypted in the EEFMT2 format (for both the 3592 Model E05 and the 3592 Model E06).



DEB2XEEF - 3592-E05/E06 WRITING IN EEFMT2 RECTECH  
DEB2XEE3 - 3592-E06 WRITING IN EEFMT3 RECTECH  
DEB2XENC - TAPE CARTRIDGE ENCRYPTED

OPEN will also set new bit DEB2XEF2 if the cartridge, on a 3592 Model E06, is written in the lower recording format EFMT2. This is similar to the existing DEB2XEF1 bit that indicates that the cartridge, on a 3592 Model E05, is written in the lower recording format EFMT1.

DEB2XEF2 - 3592-E06 WRITING IN EFMT2 RECTECH



---

## Chapter 20. DFSMSdss considerations for the TS1130 tape drive

DFSMSdss, a z/OS functional component, allows you to copy, move, dump, and restore data sets and volumes. DFSMSdss is the primary data mover of DFSMS.

This topic describes considerations for using DFSMSdss with the encryption capable TS1130 tape drive, as follows:

- “DFSMSdss handling of hardware encryption.”
- “Updates to the DFSMSdss Application Programming Interface.”

---

### DFSMSdss handling of hardware encryption

Using TS1130 tape drives does not require changes to your installation's DFSMSdss jobs. When at least one of the output devices is encrypting data and you request software encryption, DFSMSdss overrides software encryption request for the output devices that encrypt data, and does not write to the output devices that do not encrypt data. To indicate that the tape device is encrypting data, DFSMSdss sets to one the following bits in the ADREID0 mapping: the EI26TWHE bit for the Volume Output Notification Exit (EXIT26), and the EI06THWE bit for the Write Physical Tape Exit (EXIT06). If you do not request software encryption, DFSMSdss can write to multiple output devices some of which are encrypting data in the hardware and some are not. DFSMSdss continues to inform your application whether a tape device is encrypting data and if all of the data is processed. For more information on how DFSMSdss handles hardware encryption, see “Planning to use hardware encryption for dump tapes” on page 235.

---

### Updates to the DFSMSdss Application Programming Interface

In support of the TS1130 tape drive the following new fields are added to the ADREID0 data area to allow an installation-supplied program to determine whether a tape device is encrypting data:

#### **EI00SWNCRYPT**

DFSMSdss sets this bit on to indicate that software encryption is requested. You can reference this bit, but you should not change it.

#### **EI00CANSFE**

You can set this bit on to indicate that software encryption is to be cancelled. DFSMSdss honors this bit only when the EI00SWNCRYPT bit is turned on.

#### **EI00MIXDEV**

You can set this bit on to indicate that the data is to be written to a mixture of devices where some are encrypting the data and some are not. DFSMSdss honors this bit only when the EI00SWNCRYPT bit is turned on.

Table 21 on page 132 shows the ADREID0 mapping.

Table 21. ADREID0 Mapping

Offsets		Type	Len	Name (Dim)	Description
Dec	Hex				
0	(0)	STRUCTURE	16	EIREC00	
0	(0)	UNSIGNED	1	EI00SBPL	SHARED SUBPOOL NUMBER
1	(1)	BITSTRING	1	EI00FLGS	STARTUP FLAGS
		1... ....		EI00SENQ	SHORT VTOC ENQUEUE
		.1.. ....		EI00NONF	DO NOT ALLOW IGWNOTIF CALL
		..1. ....		EI00NOLK	DO NOT PERFORM ADRLOCK ENQUEUE OR DEQUEUE
		...1 ....		EI00NENQ	NO INPUT VOLUME SERIALIZATION. VALID DURING PHYSICAL COPY AND DUMP FUNCTION STARTUPS
		.... 1..		EI00BSEC	BYPASS SECURITY VERIFICATION FOR DATA SETS ON THE VOLUME DURING COPY FULL/TRACKS, DUMP FULL/TRACKS, AND RESTORE FULL/TRACKS FUNCTION STARTUPS
		.... .1..		EI00MVOLRECOV	1=CALLER IS PERFORMING A MULTI-VOLUME RECOVERY USING PHYSICAL DATA SET RESTORE AND IT IS ACCEPTABLE FOR DFSMSDSS TO SCRATCH PREALLOCATED TARGET DATA SETS THAT ARE NOT THE CORRECT SIZE
		.... ..1.		EI00BSER	1=BYPASS SERIALIZATION OF THE DATA SETS BEING RESTORED DURING A PHYSICAL DATA SET RESTORE OPERATION
		.... ..1		*	RESERVED
2	(2)	CHARACTER	6	EI00SVOL	SOURCE VOLSER. VALID DURING COPY FULL/TRACKS, DUMP FULL/TRACKS, AND RESTORE FULL/TRACKS FUNCTION STARTUPS. FOR RESTORE, THIS FIELD CONTAINS THE VOLSER OF THE INPUT VOLUME WHERE THE DUMP DATA SET RESIDES
8	(8)	BITSTRING	1	EI00FLG2	SECOND FLAG AREA
		1... ....		EI00SWNCRYPT	SOFTWARE ENCRYPTION WAS REQUESTED (RSA OR KEYPASSWORD WAS SPECIFIED)
		.1.. ....		EI00CANSFE	CANCEL SOFTWARE ENCRYPTION
		..1. ....		EI00MIXDEV	MIXTURE OF DEVICES; SOME ARE PERFORMING HARDWARE ENCRYPTION AND OTHERS ARE NOT.
		...1 1111		*	RESERVED
9	(9)	CHARACTER	7	*	RESERVED

---

## Chapter 21. DFSMSHsm considerations for the TS1130 tape drive

DFSMSHsm, a z/OS functional component, automatically manages low activity and inactive data in both system-managed and non-system-managed environments. DFSMSHsm also provides automatic backup and recovery of active data in those environments.

DFSMSHsm can use the TS1130 tape drive (3592 Model E06, 3592-3E) for all functions. DFSMSHsm normally uses non-WORM media (MEDIA5, MEDIA7, MEDIA9) for non-ABARS functions. DFSMSHsm uses all media, including WORM (MEDIA6, MEDIA8 and MEDIA10) for ABARS processing. DFSMSHsm can use the WORM media for non-ABARS processing if specifically allowed by your installation.

This topic describes these considerations for using DFSMSHsm with the TS1130 tape drive:

- “Modifying your SMS data classes”
- “Modifying your dump classes”
- “Input tape utilization” on page 134
- “Requesting information for encrypted volumes and tapes” on page 134
- “Requesting information for dump volumes” on page 135
- “Specifying esoteric tape unit names to DFSMSHsm” on page 136
- “Tape Hardware Emulation” on page 136
- “Specifying how much of a tape DFSMSHsm uses” on page 136
- “Using tape device naming conventions” on page 137
- “Output tape selection” on page 138
- “Output tape utilization” on page 138
- “Allowing DFSMSHsm to use the 3590-1 generic unit when it contains mixed track technology drives” on page 139
- “Recovering overwritten encrypted tapes” on page 139
- “DFSMSHsm tips” on page 139.

---

### Modifying your SMS data classes

To use tape hardware encryption, you must modify your SMS data class definitions to request encryption from the encryption-capable tape drives.

---

### Modifying your dump classes

The method for requesting encryption depends on whether you plan to use hardware encryption or host-based encryption, as follows:

- To request hardware encryption for a dump class, specify it in the SMS data class for the dump data.
- To request host-based encryption for a dump class, use the DFSMSHsm DEFINE DUMPCLASS(ENCRYPT) command. With ENCRYPT, include the RSA or KEYPASSWORD subparameters to specify the type of host-based encryption. ENCRYPT(NONE) specifies host-based encryption should not be done.

If your dump classes are currently defined to use host-based encryption (and possibly host-based compression before encryption), it is recommended that you remove the host-based encryption requests from any dump classes for which you plan to use tape hardware encryption.

During the process of migrating your dump classes to use hardware encryption, you might have some dump classes that are still defined to use host-based encryption, while their associated SMS data classes are defined to use tape hardware encryption. Here, DFSMSdss ignores requests for host-based encryption for these tape volumes and, instead, uses hardware encryption. This processing allows you to complete the migration to hardware encryption without having to modify your dump-requesting jobs. However, removing host-based encryption requests from a dump class when tape hardware encryption is also requested can avoid confusion concerning which process is active.

**Note:**

1. To determine whether hardware encryption or host-based encryption was used for a particular tape volume, check the associated dump volume record (DVL).
2. If more than one dump class is specified (creating more than one dump copy), those dump classes specify host-based encryption, each dump class has a unique data class assigned, and some but not all of the associated data classes request tape hardware encryption, then all dump copies will fail. In other words, tape hardware encryption can override host-based encryption for all dump classes associated with a source volume or none of the dump classes, but it cannot override a subset of those dump classes.

**Related reading:**

- For more information on the DEFINE DUMPCLASS command, see *z/OS DFSMSdss Storage Administration*.

---

## Input tape utilization

In an SMS environment, the choice of an input drive for a particular tape is controlled by the library and is transparent to DFSMSHsm.

In a non-SMS environment, the choice of drives is controlled by the unit name recorded in the tape's CDS records. This unit name is the name of the original output unit selected by the installation, or its generic equivalent. In a mixed non-SMS environment where more than one tape technology is associated with a generic unit name, you must use esoteric names for the output unit and its associated input unit.

DFSMSHsm can use MEDIA5, MEDIA6, MEDIA7, MEDIA8, MEDIA9, and MEDIA10 as input. The MEDIA5, MEDIA6, MEDIA7, and MEDIA8 tapes may be in either the EFMT1, EFMT2, EEFMT2, EFMT3, or EEFMT3 recording technology. The MEDIA9 and MEDIA10 tapes can only be in the EFMT2, EEFMT2, EFMT3, or EEFMT3 recording technology. The choice of the correct recording technology when mounted on a 3592-E06 is transparent to DFSMSHsm.

---

## Requesting information for encrypted volumes and tapes

New values EFMT3 and EEFMT3 are added to the SELECT parameter of the DFSMSHsm LIST TTOC command to allow you to list tape volumes with and without tape hardware encryption.

This shows a portion of the syntax for the LIST TTOC command:

## N: TTOC SELECT Optional Parameters:

NOALTERNATEVOLUME
FAILEDRECYCLE
EXCESSIVEVOLUMES
FAILEDCREATE
DISASTERALTERNATEVOLUMES
ALTERNATEVOLUME
RECALLTAKEAWAY
CAPACITYMODE
EMFT1
EMFT2
EEFMT2
EFMT3
EEFMT3
ENCRYPTION
NOENCRYPTION

### Related reading:

For more information on the LIST TTOC command, see *z/OS DFSMSdfp Storage Administration*.

## Displaying EFMT3 and EEFMT3 formatted volumes

You can use the LIST TTOC command to list volumes based on the recording technology used. To list all volumes recorded in EFMT3 format, enter the LIST TTOC command as follows:

```
LIST TTOC SELECT(EFMT3) ODS(ttoc.out.dataset)
```

To list all volumes recorded in EEFMT3 format, enter the LIST TTOC command as follows:

```
LIST TTOC SELECT(EEFMT3) ODS(ttoc.out.dataset)
```

## Displaying encrypted tape volumes

You can use the LIST TTOC command to list tape volumes that were encrypted through hardware encryption. To do so, enter the LIST TTOC command as follows:

```
LIST TTOC SELECT(ENCRYPTION) ODS(ttoc.out.dataset)
```

You can also use the LIST TTOC command to list tape volumes that were not encrypted through hardware encryption. To do so, enter the LIST TTOC command as follows:

```
LIST TTOC SELECT(NOENCRYPTION) ODS(ttoc.out.dataset)
```

---

## Requesting information for dump volumes

For a list of the information for a specific dump volume managed by DFSMSShsm, specify the LIST command with the DUMPVOLUME(*volser*) parameter. If the volume was tape hardware encrypted, the ENC field will indicate THW.

For a list of the information for the dump volumes of the requested status managed by DFSMSShsm, specify the LIST command with the DUMPVOLUME parameter without the volume serial number. Instead, include a status parameter such as AVAILABLE, UNAVAILABLE, EXPIRED, UNEXPIRED, or NORETENTIONLIMIT. The command lists the volumes in alphanumeric sequence by volume serial number.

**Related reading:**

For more information on the LIST DUMPVOLUME command, see *z/OS DFSMSdfp Storage Administration*.

---

## Specifying esoteric tape unit names to DFSMSHsm

When using the SETSYS USERUNITTABLE command to specify esoteric tape unit names to DFSMSHsm, note that DFSMSHsm rejects mixed combinations of device names in an esoteric group, with these exceptions:

- It allows the use of both 3480 and 3480X device names in a single group. Improved Data Recording Capability (IDRC), however, is not used with such a group because all devices in the group are treated as 3480s. If an esoteric group associated only with 3480Xs exists, 3480s should not be added to it, because the data already written using this esoteric tape unit name may create IDRC incompatibilities.
- 3592-1, 3592-2, and 3592-2E tape units are allowed into the same esoteric since they share common write formats. 3592-2, 3592-2E, and 3592-3E tape units are allowed into the same esoteric since they also share common write formats. It is up to the user to ensure the drives in a mixed esoteric will be used with a common recording technology. For example, if any 3592-1 drives are included, then all drives in the esoteric must use EMFT1 for output. If the esoteric mixes 3592-2 and 3592-2E drives, then all drives must be set up to use EFMT1 or EFMT2. If the esoteric contains mixed 3592-3E and 3592-2E tape units, then all drives must be set up to use EFMT2 or EEFMT2, the write formats they have in common.

**Note:**

1. If DFSMSHsm rejects an esoteric tape unit name, it does not reject the rest of the valid esoteric names specified in the USERUNITTABLE command. Those names are now recognized by DFSMSHsm as valid esoteric tape unit names. Each time you specify USERUNITTABLE, the valid esoteric tape unit names identified with this parameter replace any esoteric tape unit names identified through a previous USERUNITTABLE parameter of the SETSYS command.

**Related reading:**

- For more information on the SETSYS command, see *z/OS DFSMSdfp Storage Administration*.

---

## Tape Hardware Emulation

- The 3592-E06, as with the 3592-E05, always runs in emulation mode as a 3590-B1x tape drive.
- The 3590-E1x, 3590-H1x, and the 3592-J1A drives emulate either a 3490-E1x or 3590-B1x.

---

## Specifying how much of a tape DFSMSHsm uses

**For 3592 devices:** | to data on a MEDIA5 or MEDIA9 tape, consider using the 3592 performance scaling feature. In DFSMSHsm, performance scaling applies in both tape libraries and standalone environments.

Performance scaling uses 20% of the physical space on each tape and keeps data sets closer together and closer to the initial load point. Performance scaling permits the same amount of data to exist on a larger number of tapes, allowing more input



tasks to run concurrently. With performance scaling, you can effectively increase the "bandwidth" of operations that read data in from tape.

In contrast, performance segmentation allows the use of most of the physical media, while enhancing performance for the first and last portions of the tape.

**Related reading:**

- For more information about implementing DFSMSHsm tape environments, see *z/OS DFSMSdfp Storage Administration*.

## Using tape device naming conventions

Table 22 shows the hardware (marketing device name) and software (MVS generic device name) names for 3592 tape devices. The MVS generic device names are also the names used by the job control language (JCL) to communicate with the z/OS operating system. Use the MVS generic name or your installations esoteric name in any JCL statements or DFSMSHsm commands that specify device names.

*Table 22. Tape device naming conventions*

Device description	Hardware name	Generic MVS name
<p><b>3592-3E</b></p> <ul style="list-style-type: none"> <li>• Enterprise recording format EFMT1 (readonly), EFMT2, EEFMT2, EFMT3, EEFMT3</li> <li>• IBM TotalStorage Enterprise tape cartridge (MEDIA5, MEDIA6, MEDIA7, MEDIA8, MEDIA9, MEDIA10)</li> <li>• Always in "emulation mode" as a 3590B device.</li> </ul>	<b>3592-E06</b>	<b>3590-1</b>
<p><b>3592-2E</b></p> <ul style="list-style-type: none"> <li>• Enterprise recording format: EFMT1, EFMT2, EEFMT2</li> <li>• IBM TotalStorage Enterprise tape cartridge (MEDIA5, MEDIA6, MEDIA7, MEDIA8, MEDIA9, MEDIA10)</li> <li>• Always in "emulation mode" as a 3590B device.</li> </ul>	<b>3592-E05</b>	<b>3590-1</b>
<p><b>3592-2</b></p> <ul style="list-style-type: none"> <li>• Enterprise recording format: EFMT1, EFMT2</li> <li>• IBM TotalStorage Enterprise tape cartridge (MEDIA5, MEDIA6, MEDIA7, MEDIA8, MEDIA9, MEDIA10)</li> <li>• Always in "emulation mode" as a 3590B device.</li> </ul>	<b>3592-E05</b>	<b>3590-1</b>
<p><b>3592-J</b></p> <ul style="list-style-type: none"> <li>• Enterprise recording format: EFMT1</li> <li>• IBM TotalStorage Enterprise tape cartridge (MEDIA5, MEDIA6, MEDIA7, MEDIA8)</li> <li>• In "emulation mode" as a 3590B device (or 3490E tape drives with MEDIA5 tape cartridge media only). In a system-managed tape library environment (manual or automated), only 3590B emulation is supported.</li> </ul>	<b>3592-J1A</b>	<b>3590-1</b>

---

## Output tape selection

DFSMSHsm can select TS1130 tape drives (3592-3E) for output in SMS and non-SMS tape environments.

---

## Output tape utilization

DFSMSHsm writes to 97% of the capacity of MEDIA5, MEDIA6, MEDIA7, MEDIA8, MEDIA9, and MEDIA10 tapes unless otherwise specified by the installation. Other percentages can be specified through the SETSYS TAPEUTILIZATION command, depending on the particular needs of the installation.

### Scratch Tapes

The 3592-E06 can utilize scratch MEDIA5, MEDIA7, and MEDIA9 tapes for all DFSMSHsm functions. It can also utilize scratch MEDIA 6, MEDIA8, and MEDIA10 tapes for ABARS. The 3592-E06 can write in EFMT3, EEFMT3, EFMT2, and EEFMT2 recording technologies. The recording technology used on scratch media is controlled by the data class assigned to the tape by the ACS routines. If no recording technology is specified the default of EFMT3 is used.

The ACS routines often use the single file format tape data set name to make the data class selection. This control is transparent to DFSMSHsm.

### Partial Tapes

When the 3592-E06 uses a partial tape for output, the existing data on tape may be in either the EFMT2, EEFMT2, EFMT3, or EEFMT3 recording technologies. The tape will be extended in the same format. The choice of the correct recording technology will be transparent to DFSMSHsm. MEDIA6, MEDIA8, and MEDIA10 tapes are normally (unless patched by the customer) only used by ABARS and only as scratch tapes.

The 3592-J1A and 3592-E05 might also use these same partial tapes. The 3592-1 will not select EFMT2, EEFMT2, EFMT3, or EEFMT3 partial tapes. The 3592-2 will not select EEFMT2, EFMT3, or EEFMT3 partial tapes. The 3592-2E will not select EMFT3 or EEFMT3 partial tapes. The 3592-E06 will not select EFMT1 partial tapes.

---

## Input tape utilization

DFSMSHsm can utilize MEDIA5, MEDIA7, and MEDIA9 as input for all functions and additionally use MEDIA6, MEDIA8, and MEDIA10 with the ABARS function. The MEDIA5, MEDIA6, MEDIA7, and MEDIA8 tapes may be in either the EFMT1, EFMT2, EEFMT2, EFMT3, or EEFMT3 recording technology. The MEDIA9 and MEDIA10 tapes can only be in the EFMT2, EEFMT2, EFMT3, or EEFMT3 recording technology. The choice of the correct recording technology when they are mounted on a 3592-E06 will be transparent to DFSMSHsm.

### Reuse Capacity

The current scheme has one reuse capacity for each media type regardless of the recording technology. This encourages media used with multiple recording technologies to move from older to newer technologies. This scheme will continue with 3592-E06.

## Mixed Device Esoteric Units

Keeping with the philosophy of allowing only write compatible tape devices to coexist in the same esoteric, 3592-E06 drives will be allowed in the same esoteric with 3592-E05 drives (both encryption capable and non-encryption capable) but not allowed in the same esoteric with 3592-J1A drives. The read-only compatibility between the 3592-E06 and 3592-J1A (of the EFMT1 format) does not meet the write-compatibility requirements for a mixed esoteric. In a stand-alone (non IBM library) tape environment, the user must make sure all drives in a mixed esoteric will use a recording technology they have in common when they write data to tape. For 3592-E05 and 3592-E06 drives the common recording technologies for read and write are EFMT2 and EEFMT2.

## Conversion of Tapes from D/T3490 to D/T3590

You can re-addvol partial D/T3490 tapes created by 3592-J1A drives to D/T3590 tapes associated with 3592-E06 unit names. The tapes will be marked full so the 3592-E06 drives do not try to extend them and they can only be mounted for input.

---

## Allowing DFSMShsm to use the 3590-1 generic unit when it contains mixed track technology drives

You might encounter a situation in which you need to use the 3590-1 generic unit when it contains a mixture of 3590 devices that cannot share tapes. If so, you must use other means, such as SMS ACS routines, to keep these drives separate, and you can use this patch to disable the DFSMShsm compatibility checking:

```
PATCH .MCVT.+3D5 BITS(.1.....)
```

You can use this patch to re-enable the DFSMShsm compatibility checking:

```
PATCH .MCVT.+3D5 BITS(.0.....)
```

By default, checking is enabled for non-SMS tape allocations.

A non-SMS tape allocation for a generic unit 3590-1 containing mixed track technologies causes DFSMS to issue message ARC0030I. Here, DFSMShsm allows the allocation to continue, but a tape/tape unit mismatch can result in an OPEN failure.

DFSMShsm does not issue message ARC0030I for a mix of 3592-1, 3592-2, and 3592-2E tape units, nor for a mix of 3592-2, 3592-2E, and 3592-3E tape units, since they can write using a common recording technology.

---

## Recovering overwritten encrypted tapes

Recovery of overwritten encrypted tape volumes might not be possible; the tape recovery process described in the topic "Case 6: Overwritten Migration Tape" of *z/OS DFSMSdfp Storage Administration* does not work for an encrypted tape.

---

## DFSMShsm tips

See "DFSMShsm tips" on page 313 for some tips that you might find helpful when using DFSMShsm with the TS1130 tape drive.



---

## Chapter 22. DFSMSrmm modifications for TS1130 tape drive

DFSMSrmm is a feature of z/OS. It manages all tape media, such as cartridge system tapes and 3420 reels, and other removable media that you define to it. The DFSMSrmm modifications for the TS1130 tape drive include updates to:

- EDGINERS ERASE
- DFSMSrmm TSO subcommands
- REXX variables of the TSO subcommand
- API structured field introducers
- Mapping macros fields

### Related reading:

- See *z/OS DFSMSrmm Managing and Using Removable Media* for the complete syntax of the DFSMSrmm ADDVOLUME subcommand, the DFSMSrmm CHANGEVOLUME subcommand, the DFSMSrmm SEARCHVOLUME subcommand, DFSMSrmm return codes and reason codes, and REXX variables.
- See *z/OS DFSMSrmm Application Programming Interface* for further information about the DFSMSrmm API.
- See *z/OS DFSMSrmm Implementation and Customization Guide* and *z/OS DFSMSrmm Reporting* for additional information about DFSMSrmm mapping macros.

---

## EDGINERS ERASE function

The EDGINERS ERASE function now optionally exploits new hardware capability to perform a 'data key shred' for encrypted tape volumes instead of using a secure data erase. If the 'data key shred' is not possible, a secure data erase is performed instead.

The ERASE release action can now be configured to selectively perform a shred, a secure data erase, or a combination of the two. When the ERASE release action is pending for an encrypted tape volume, and the volume is mounted for ERASE on an encryption capable tape drive, and the appropriate ERASE option is selected, the EDGINERS utility attempts a 'shred' action on the volume. 'Shred' removes the EEDK structures on the tape. This renders the data incapable of being decrypted. EDGINERS ERASE processing also supports options to use a combination of secure data erase with shred, or to force a secure data erase even for encrypted volumes.

## EXEC Parameters for EDGINERS

Figure 8 on page 142 describes the EXEC parameters.

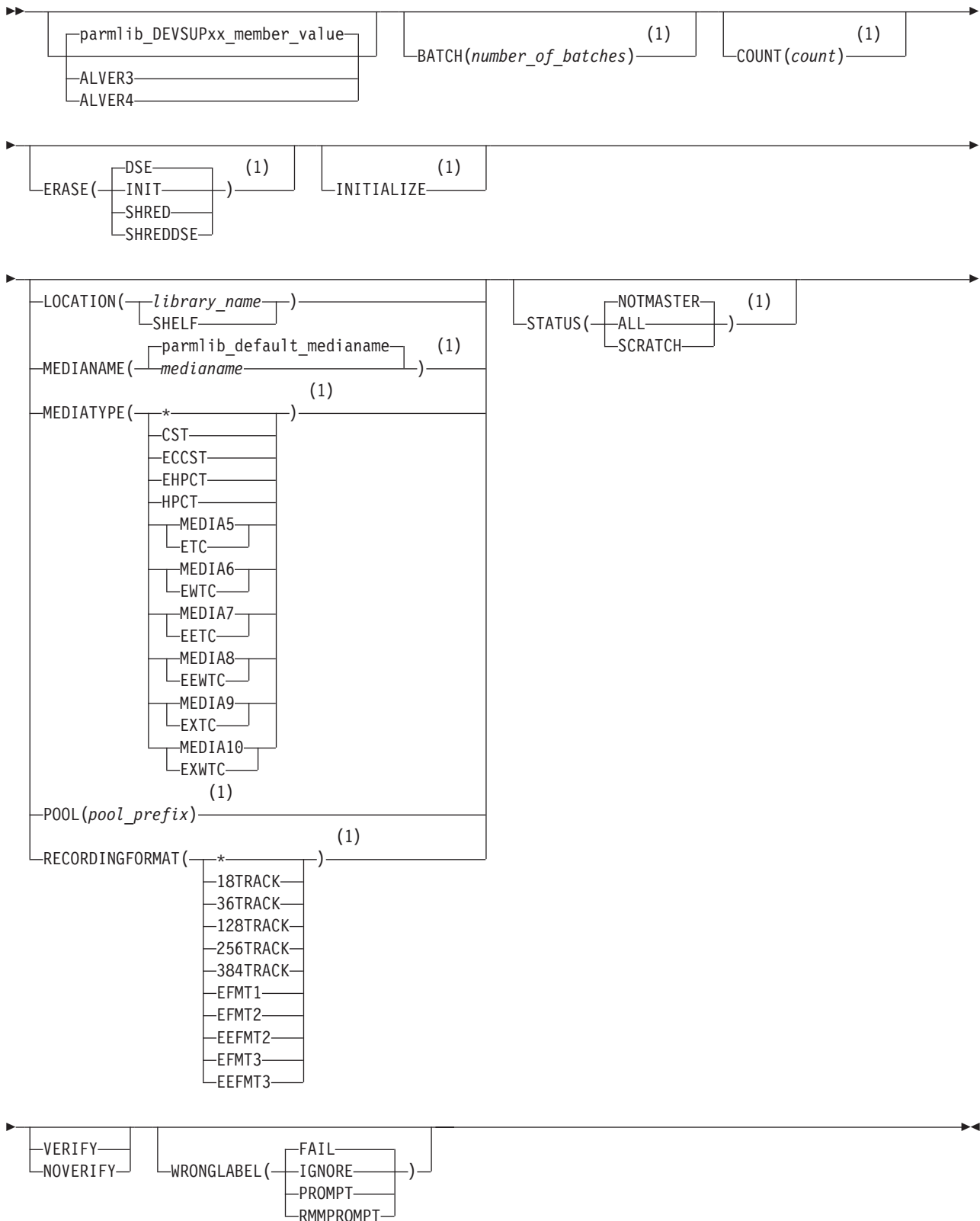

**Notes:**

1 Specify this parameter for automatic processing.

Figure 8. EDGINERS EXEC Parameters

### **ERASE(DSE|INIT|SHRED|SHREDDSE)**

Use ERASE to request that DFSMSrmm selects volumes that have the erase action pending. If automatic processing is in effect but ERASE is not specified then DFSMSrmm will only select volumes with the initialize action pending. When you specify ERASE, DFSMSrmm performs automatic processing.

ERASE can be specified either as **ERASE** or as **ERASE(value)**. Specifying ERASE without a value (that is, as **ERASE**) is the same as specifying **ERASE(DSE)**. You can optionally specify one of the following values for ERASE to select the action to be performed by the tape drive:

#### **DSE**

Specifies that a Data Secure Erase (DSE) should be attempted. This exploits the tape drive hardware capability to erase data from the volume. This is the default value if the ERASE parameter is omitted or specified without a value.

#### **INIT**

Specifies that an ERASE action equates to an INIT action; no secure erase is attempted and the volume is relabelled as if the INIT action had been requested.

#### **SHRED**

For encrypted volumes, this value specifies that the Data Key should be made unusable by the drive. For non-encrypted volumes the DSE action is attempted.

#### **SHREDDSE**

For encrypted volumes, this value specifies that the Data Key should be made unusable by the drive, and that any non-encrypted residual data on the volume should be subject to DSE. For non-encrypted volumes, the DSE action is attempted.

### **RECORDINGFORMAT(\*| 18TRACK | 36TRACK | 128TRACK | 256TRACK | 384TRACK | EFMT1 | EFMT2 | EEFMT2 | EFMT3 | EEFMT3)**

Use RECORDINGFORMAT to specify a subset of volumes for automatic processing. RECORDINGFORMAT specifies the basic recording format for tape volumes.

#### **EEFMT3**

Data has been written to the volume in EEFMT3 (enterprise encrypted format 3) recording format. A recording format of EEFMT3 is valid with MEDIATYPE(MEDIA5, MEDIA6, MEDIA7, MEDIA8, MEDIA9, and MEDIA10) only.

#### **EFMT3**

Data has been written to the volume in EFMT3 (enterprise format 3) recording format. A recording format of EFMT3 is valid with MEDIATYPE(MEDIA5, MEDIA6, MEDIA7, MEDIA8, MEDIA9, and MEDIA10) only.

## **SYSIN Commands for EDGINERS**

Use the SYSIN commands for manual processing. You must use separate SYSIN commands for each volume you want initialized or erased. The format of the SYSIN commands and operator replies are shown in Figure 9 on page 144.

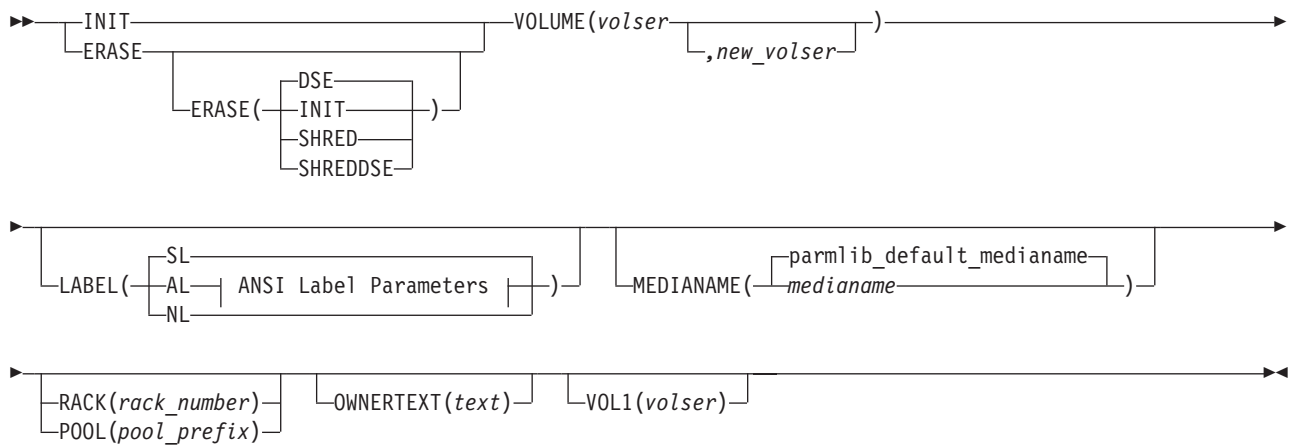

**ANSI Label parameters:**

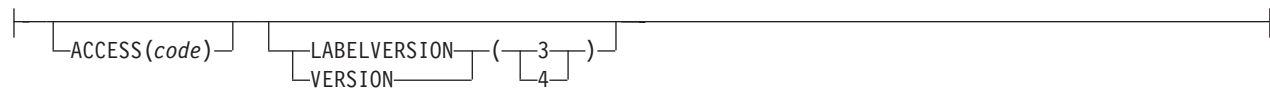

Figure 9. EDGINERS SYSIN Commands

**ERASE**

Specify ERASE to security erase a volume and write a new label on it.

You must specify either ERASE or INIT.

**ERASE (DSE | INIT | SHRED | SHREDDSE)**

Use the ERASE operand on an ERASE command to tailor the ERASE action to be performed.

You can optionally specify the ERASE operand of the ERASE command to specify a value for ERASE to select the action to be performed by the tape drive for the ERASE action. The following values can be specified:

**DSE**

Specifies that a Data Secure Erase (DSE) should be attempted. This exploits the tape drive hardware capability to erase data from the volume. This is the default value for the ERASE operand.

**INIT**

Specifies that an ERASE action equates to an INIT action; no secure data erase is attempted and the volume is relabelled as if the INIT action had been requested.

**SHRED**

For encrypted volumes, this value specifies that the Data Key should be made unusable by the drive. For non-encrypted volumes the DSE action is attempted.

**SHREDDSE**

For encrypted volumes, this value specifies that the Data Key should be made unusable by the drive, and that any non-encrypted residual data on the volume should be subject to DSE. For non-encrypted volumes, the DSE action is attempted.



## DFSMSrmm TSO subcommands

This section describes the updates to these DFSMSrmm TSO subcommands:

- ADDVOLUME
- CHANGEVOLUME
- SEARCHVOLUME
- ADDDATASET
- CHANGEDATASET
- LISTDATASET
- LISTVOLUME

### ADDVOLUME

The ADDVOLUME TSO subcommand adds volumes to the DFSMSrmm control data set. This diagram shows the syntax of the MEDIATYPE operand and the RECORDINGFORMAT operand for the ADDVOLUME TSO subcommand.

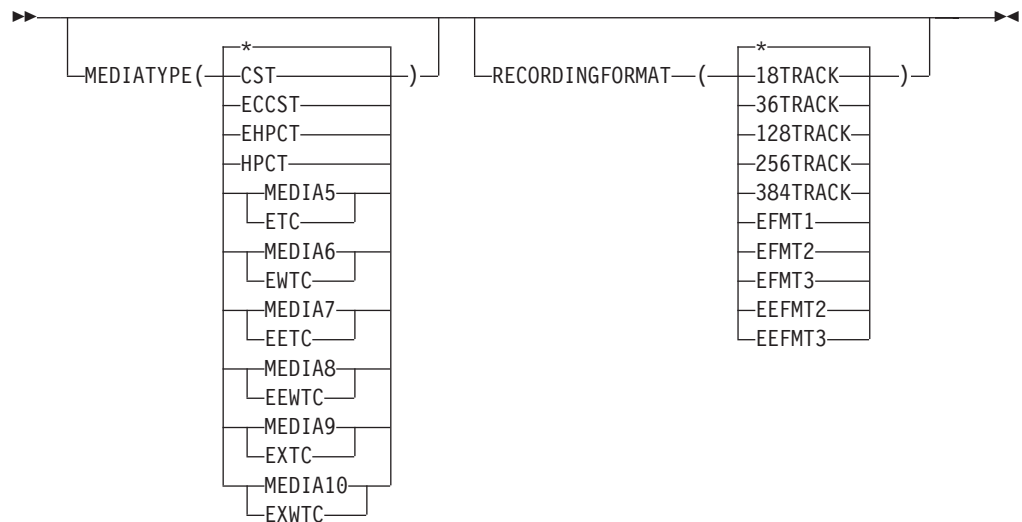

#### EFMT3

Data has been written to the volume in EFMT3 (enterprise format 3) recording format. A recording format of EFMT3 is valid with MEDIATYPE(MEDIA5, MEDIA6, MEDIA7, MEDIA8, MEDIA9, and MEDIA10) only.

#### EEFMT3

Data has been written to the volume in EEFMT3 (enterprise encrypted format 3) recording format. A recording format of EEFMT3 is valid with MEDIATYPE(MEDIA5, MEDIA6, MEDIA7, MEDIA8, MEDIA9, and MEDIA10) only.

To use the EFMT3 and the EEFMT3 recording technology, you must specify the MEDIATYPE(MEDIA5/ETC, MEDIA6/EWTC, MEDIA7/EETC, MEDIA8/EEWTC, MEDIA9/EXTC, or MEDIA10/EXWTC) operand of the ADDVOLUME TSO subcommand.

### CHANGEVOLUME

The CHANGEVOLUME TSO subcommand updates details for a volume defined to DFSMSrmm. This diagram shows the syntax of the MEDIATYPE operand and the RECORDINGFORMAT operand for the CHANGEVOLUME TSO subcommand.

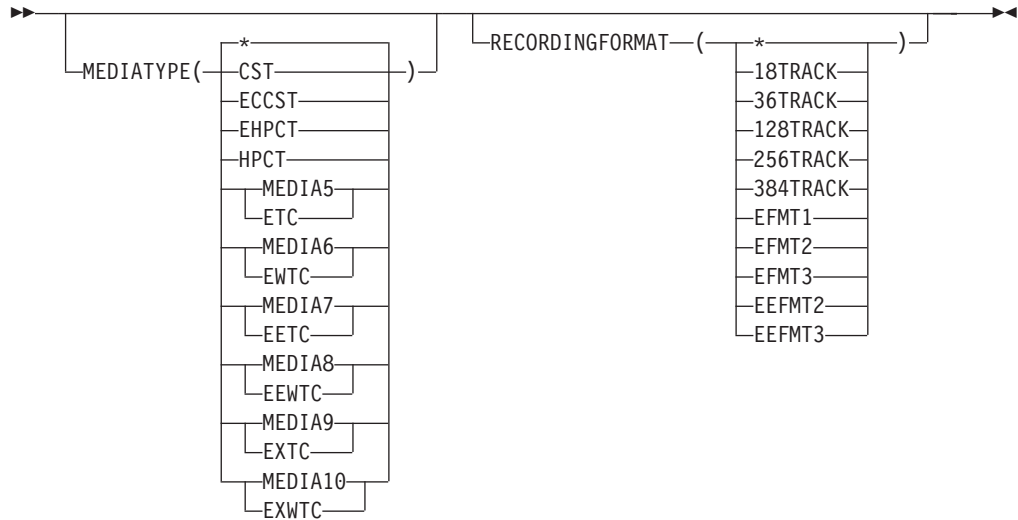

### EFMT3

Data has been written to the volume in EFMT3 (enterprise format 3) recording format. A recording format of EFMT3 is valid with MEDIATYPE(MEDIA5, MEDIA6, MEDIA7, MEDIA8, MEDIA9, and MEDIA10) only.

### EEFMT3

Data has been written to the volume in EEFMT3 (enterprise encrypted format 3) recording format. A recording format of EEFMT3 is valid with MEDIATYPE(MEDIA5, MEDIA6, MEDIA7, MEDIA8, MEDIA9, and MEDIA10) only.

To use the EFMT3 and the EEFMT3 recording technology, you must specify the MEDIATYPE(MEDIA5|ETC, MEDIA6|EWTC, MEDIA7|EETC, MEDIA8|EEWTC, MEDIA9|EXTC, or MEDIA10|EXWTC) operand of the CHANGEVOLUME TSO subcommand.

## SEARCHVOLUME

You can use the SEARCHVOLUME TSO subcommand to obtain a list of volumes that match selection criteria that you specify. Specify EEFMT3 to limit your search to volumes that are written in the EEFMT3 recording technology. You can also specify a particular media type, such as MEDIA9, to then further limit your search. This diagram shows the syntax of the MEDIATYPE operand and the RECORDINGFORMAT operand for the SEARCHVOLUME TSO subcommand.

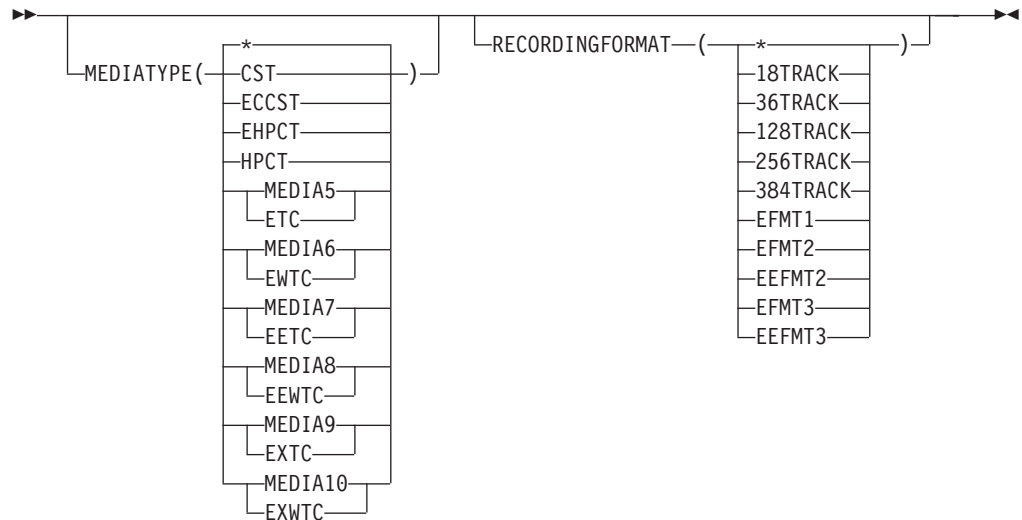

## ADDDATASET

Use the ADDDATASET TSO subcommand to manually define a data set on a volume to DFSMSrmm. The volume on which the data set resides must have either master or user status.

### **BLKCOUNT** (*number\_of\_blocks*)

Specifies the number of data blocks used by the data set. The value corresponds to that recorded in the data set's End of File label. The minimum allowable decimal value is 0; the maximum allowable decimal value is 99999999. DFSMSrmm uses BLKCOUNT, together with BLKSIZE, to calculate the approximate size of the data set and the sum of all data set sizes to set the volume usage. If you do not use BLKCOUNT, DFSMSrmm cannot list the space used for the data set or volume when you request it. The default value is 0.

**Note:** The total block count cannot be set or changed by subcommand. It is set based on information recorded during CLOSE processing.

### **BLKSIZE** (*block\_size*)

Specifies the block size of the data set. The minimum allowable decimal value is 0; the maximum allowable decimal value is 999999. DFSMSrmm uses BLKSIZE together with BLKCOUNT to calculate the approximate size of the data set and the sum of all data set sizes to set the volume usage. If you do not use BLKSIZE, DFSMSrmm cannot report space usage. The default value is 0.

## CHANGEDATASET

Use the CHANGEDATASET TSO subcommand to update information about data sets defined to DFSMSrmm.

### **BLKCOUNT** (*number\_of\_blocks*)

Specifies number of data blocks used by the data set. The value corresponds to that recorded in the data set's End of File label. The minimum allowable decimal value is 0; the maximum allowable decimal value is 99999999. DFSMSrmm uses BLKCOUNT together with BLKSIZE to calculate the data set's approximate size and the sum of all data set sizes to set the volume usage.

**Note:** The total block count cannot be set or changed by subcommand. It is set based on information recorded during CLOSE processing.

**BLKSIZE**(*block\_size*)

Specifies the data set's block size. The minimum allowable decimal value is 0; the maximum allowable decimal value is 999999. DFSMSrmm uses BLKSIZE together with BLKCOUNT to calculate the data set's approximate size and the sum of all data set sizes to set the volume usage. If the volume is OCE recorded, you can only specify this operand if you are authorized to use the FORCE operand.

## LISTDATASET

You can use the LISTDATASET TSO subcommand to display information that is recorded by DFSMSrmm for a single data set. In addition to the previously displayed information, LISTDATASET now also displays the data set size .

To request information recorded by DFSMSrmm for the data set ADSM.BFS on volume MAA269, issue the command:

```
RMM LISTDATASET 'ADSM.BFS' volume(MAA269)
```

DFSMSrmm displays information such as that shown:

```
Data set name = ADSM.BFS
Volume       = MAA269           Physical file sequence number = 1
Owner        =                  Data set sequence = 1
Create date  = 04/29/2008 Create time = 17:51:00 System ID       = EDS1
Expiration date = 05/29/2008 Original expir. date =
Block size   = 262144          Block count       = 1
Data set size(KB) = 256
Percent of volume = 0          Total block count = 1
Logical Record Length = 0      Record Format    = U
Date last written = 04/29/2008 Date last read   = 04/29/2008
Job name      = ADSM           Last job name    = ADSM
Step name     = ADSM           Last step name   = ADSM
Program name  = DSMSESV        Last program name = DSMSESV
DD name       = SYS00325       Last DD name     = SYS00325
Device number = 05C2           Last Device number = 05C2
Management class = ATLSMT      VRS management value =
Storage group = MAS3LIB1       VRS retention date = 05/01/2008
Storage class = MEDIA3         VRS retained      = NO
Data class    = ATLSM          ABEND while open  = NO
                                   Catalog status     = UNKNOWN
```

## LISTVOLUME

You can use the LISTVOLUME TSO subcommand to display information that is recorded by DFSMSrmm for a single volume. In addition to the previously displayed information, LISTVOLUME now also displays the volume usage in either KB or MB, as appropriate. You must specify a volume serial number.

To request all the information recorded by DFSMSrmm for the encrypted volume with serial number JJC024, issue the command:

```
RMM LISTVOLUME JJC024 ALL
```

DFSMSrmm displays information such as that shown:

```
Volume information:
Volume = JJC024 VOL1 =          Rack = JJC024 Owner = RMMUSER
Type = PHYSICAL           Stacked count = 0 Jobname = D016216J
Worldwide ID =
Creation: Date = 06/28/2008 Time = 04:49:14 System ID = W98MVS2
Assign:   Date =           Time =           System ID = W98MVS2
```

```

Expiration date = 09/02/2008 Original      =
Retention date  =                      Set retained = NO
Data set name = RMMUSER.TEST.CBR
Volume status:
Status = USER      Availability =                      Label = SL
Current label version =                      Required label version =
Media information:
Density = IDRC Type = EETC      Format = EFMT3      Compaction = YES
Special attributes = NONE      Vendor =
Encryption Key Labels:                      Method:
1=wccl                                          LABEL
2=wccl                                          LABEL
Action on release:
Scratch immediate = N Expiry date ignore = N
Scratch = Y Replace = N Return = N Init = N Erase = N Notify = N
Actions pending:
Scratch = N Replace = N Return = N Init = N Erase = N Notify = N
Storage group =
Loan location =                      Account = T,H,IOM,,,SYSPROG
Description =
Security class =                      Description =
Access information:
Owner access = ALTER Volume access = NONE Last change = *OCE
VM use = N MVS use = Y
Access list:
Statistics:
Number of data sets = 2      Data set recording= ON
Volume usage(MB)= 2      Use count = 3
Capacity(MB) = 2      Percent full = 0
Date last read = 08/28/2006 Date last written = 08/28/2006
Drive last used = 0FA0      Write mount count = 2
Volume sequence = 1      Media name = 3480
Previous volume =      Next volume =
Product number =      Level = V R M
Feature code =
Error counts:
Temporary read = 0      Temporary write = 0
Permanent read = 0      Permanent write = 0
Store information:
Movement tracking date =                      Intransit = N
In container =                      Move mode = AUTO
Location: Current Destination Old Required Home
Name = ATL15393
Type = AUTO
Bin number =
Media name =

```

---

## DFSMSrmm REXX variables

You can use the REXX variables to obtain volume information. The variables produced by the SEARCHVOLUME subcommand are stem variables.

*Table 23. Changed TSO subcommand REXX variables*

Variable Name	Subcommands	Contents	Format
EDG@BLKC	LD	Number of data set blocks	Numeric: 10 characters
EDG@DSS6	LD	Data set size	Character: Two concatenated fields, <i>factor</i> and <i>value</i> ; where <i>factor</i> is KB, MB, GB, or blank; and <i>value</i> is 0 to 9999999999. For example, GB720.

Table 23. Changed TSO subcommand REXX variables (continued)

Variable Name	Subcommands	Contents	Format
EDG@MEDR	LV SV	Recording technology	One of *, 18TRK, 36TRK, 128TRK, 256TRK, 384TRK, EFMT1, EFMT2, EEFMT2, EFMT3, and EEFMT3
EDG@USEM	LV	Volume usage (KB)	Numeric: -1 to 9999999999. -1 indicates that USE6 should be used.
EDG@USE6	LV	Volume usage (Application written data)	Character: Two concatenated fields, <i>factor</i> and <i>value</i> ; where <i>factor</i> is KB, MB, GB, or blank; and <i>value</i> is 0 to 9999999999. For example, GB720.

## DFSMSrmm structured field introducers

The DFSMSrmm application programming interface (API) returns data as structured fields in an output buffer that you define. Structured fields consist of a structured field introducer (SFI) and the data. SFIs describe the type, length, and other characteristics of the data.

All Structured Field Introducers (SFIs) have this format:

Bytes	Description
0-1	2-byte length: SFI length plus data length
2-4	3-byte identifier: SFI ID (hexadecimal)
5	1-byte type modifier: Type of SFI <ul style="list-style-type: none"> <li>• 0 = 8-byte, fixed-length SFI</li> </ul>
6	1-byte (Reserved)
7	1-byte data type: Type of data, if any, that follows the SFI <ul style="list-style-type: none"> <li>• 0=Undefined (no data)</li> <li>• 1=Character (fixed-length)</li> <li>• 2=Bit(8) (1-byte flag, multiple bits can be on)</li> <li>• 3=Binary(8) (1-byte (hex) value)</li> <li>• 4=Binary(15) (2-byte (hex) value)</li> <li>• 5=Binary(32) (unsigned 4-byte (hex) value)</li> <li>• 6=Binary(64) (unsigned 8-byte (hex) value)</li> <li>• 7=Character (variable-length)</li> <li>• 8=Compound SFI (multiple related values, see “Compound SFI” on page 151.)</li> <li>• 9=(4 bytes) Packed decimal Julian date: yyyydddC</li> <li>• A=(4 bytes) Packed decimal time format: hhmmssC</li> </ul>

Table 40 on page 245 shows the structured field introducers that support TS1130 tape drives.

Table 24. Changed structured field introducers

Name	Number	Type	Length	Value	Subcommands
DSS6	X'82B030'	Compound (Binary(8) Factor, Binary(64) Value)	22	Data set size factor: 0=bytes 1=KB 2=MB 3=GB Value: Minimum value = 0.	LD SD(e)
MEDR	X'857000'	Binary(8)	9	Recording technology: 0=NON-CARTRIDGE 1=18TRK 2=36TRK 3=128TRK 4=256TRK 5=384TRK 6=EFMT1 7=EFMT2 8=EEFMT2 9=EFMT3 10=EEFMT3	LV SV LC
USEM	X'8AE000'	Binary(32)	12	Volume usage (KB): Min 0, Max 4294967295. 4294967295 indicates that USE6 must be used.	LV SV(e)
USE6	X'8AE030'	Compound (Binary(8) Factor, Binary(64) Value)	22	Volume usage factor: 0=bytes 1=KB 2=MB 3=GB Value: Minimum value = 0.	LV SV(e)

## Compound SFI

A compound SFI includes multiple values each with own data type and length.

Compound type:

- 1 Factored. A Binary(8) value combined with a second field containing a count. The second field is identified by a data type.

Factor values:

- 0 Bytes (unfactored)
- 1 KB
- 2 MB
- 3 GB
- 4 TB

and so on.

Compound SFIs follow this structure;

### Byte Count

- |   | Description  |
|---|--|
| 8 | Standard SFI including 1 byte data type identifier (X'08')   |
| 1 | Compound type identifier; 1 = Factored; 2 self describing fields where the first is the factor used, and the second is the resultant value |
| 1 | Length of the first field, including this byte   |
| 1 | Data type identifier   |

- n First data field as identified by the preceding data type field; for example Binary(8)
- 1 Length of the next field, including this byte
- 1 Data type identifier
- n Next data field as identified by the preceding data type field; for example Binary(64)

---

## DFSMSrmm macros

Table 41 on page 245 shows the changes made to DFSMSrmm mapping macros for TS1130 tape drives.

*Table 25. DFSMSrmm mapping macro changes*

Mapping Macro	Function	Updates
EDGRDEXT	Maps the data set name record in the DFSMSrmm extract data set.	MB fields.
EDGRVEXT	Maps the volume records in the DFSMSrmm extract data set.	Recording technology values: EFMT3, EEFMT3. MB fields.
EDGRXEXT	Maps the extended data set records in the DFSMSrmm extract data set.	Recording technology values: EFMT3, EEFMT3. MB fields.
EDGCLREC	Maps the DFSMSrmm conversion library record.	Recording technology values: EFMT3, EEFMT3. 64 bit fields.
EDGSVREC	Maps the DFSMSrmm SMF volume records.	Recording technology values: EFMT3, EEFMT3. 64 bit fields.
EDGSDREC	Maps the data set information.	64 bit fields.
EDGSMFSY	Maps the SMF record symbols used with DFSORT.	Recording technology values: EFMT3, EEFMT3.
EDGEXTSY	Maps the extract data set symbols used with DFSORT.	Recording technology values: EFMT3, EEFMT3.

---

## Creating Reports

You can create reports that include data set size, volume usage, and capacity. Data set size and volume usage are available in both KB and factored values. If you are using existing KB values, these fields have a maximum value of 9 999 999 999 KB, or approximately, 9 TB. For larger tape volume capacities and improvements in compression, use the fields that contain values that are factored. Initially, these are in MB, but they can also be factored to TB as tape capacity increases. If you are reporting on small data sets (where the data sets size or volume capacity used is so small that you need to see the KB values), do not use the fields that contain values that are factored. If a KB byte field is no longer large enough to contain the value, the value is set to '-1'. This indicates that the factored fields should be used instead. When reporting from SMF records, data set size and volume use are recorded in 64 bit fields in KB only.



---

## Chapter 23. EREP modifications for 3592 Model E06

Environmental Recording, Editing, and Printing (EREP) program is a diagnostic application program that runs under MVS, VM, and VSE. It generates and prints reports from error recording data set (ERDS) records. With these reports, IBM service representatives can determine the existence, nature, and location of a problem.

This topic describes changes to the TAPE subsystem exception report, emulated device summary report, and TAPE Media Informational Messages (MIMs) of the EREP program to support 3592 Model E06 tape drives.

---

### TAPE subsystem exception report

In the following TAPE subsystem exception report, EREP reports a temporary ORB record in support of 3592 Model E06 tape drives.

```
TAPE SUBSYSTEM EXCEPTION REPORT                                REPORT DATE 220 05
                                                            PERIOD FROM 076 02
                                                            TO      077 02

*** SEQUENCE BY PROBABLE FAILING UNIT ***

PROBABLE  DEVICE  FAILURE  CPU  DEVNO  SIMS  MIMS  OBR  OBR
FAILING   TYPE/   AFFECT  /CUA  /CUA  MIMS  PERM  TEMP
UNIT      VOLID

*****TOTALS*****
LIBRARY                                TOTAL  0  0  0  1
      3570-CXX  LIBRARY INFORMATIONAL DATA  00  07C2  0  0  0  1
DEVICE                                TOTAL  0  0  2  1
      3590-H1X  LIBRARY DRIVE NOT UNLOADED  02  0C24  0  0  1  0
      3592-J1X  WORM OVERWRITE REJECTED  03  0C27  0  0  0  1
      3592-E05  LIBRARY DRIVE NOT UNLOADED  00  1B90  0  0  0  1
      3592-E06  LIBRARY DRIVE NOT UNLOADED  00  1B90  0  0  0  1
```

Figure 10. TAPE subsystem exception report

---

### Emulated device summary report

In the following emulated device summary report, a 3592-E06 tape drive emulates a 3590-B1X tape drive.

```
3590 DEVICE SUMMARY                                REPORT DATE 295 07
                                                            PERIOD FROM 195 06
                                                            TO      195 06

DEVICE ADDRESS  REAL  / EMULATED DEVICE TYPE
0FA2            3592-J1X / 3490-CXX
0FA3            3592-E05 / 3590-B1X
0FA4            3592-E06 / 3590-B1X
```

Figure 11. Emulated device summary report

## TAPE Media Informational Messages (MIMs)

TAPE Media Informational Messages (MIMs) now support 3592 Model E06 tape drives, as shown in the following figure.

```
TAPE MEDIA INFORMATION MESSAGES (MIMS)                REPORT DATE 028 97
                                                       PERIOD FROM 023 97
                                                       TO    028 97

*****
OLUME-JANZ01  DEVICE-0883  DATE-023/90  TIME-06:54:49:45
 * D/T-3590-B11          S/N 0113-00001
 * SERVICE ALERT        REFCODE-0057  MEDIA IDENTIFIER-0021  FORMAT IDENTIFIER-00
 * DATA DEGRADED IN PARTITION 1229
 * REFERENCE MEDIA MAINTENANCE PROCEDURE 57

VOLUME-JANZ98  DEVICE-08A9  DATE-023/90  TIME-15:35:30:19
 * D/T-359-A00          S/N 0113-23456
 * SERIOUS ALERT        REFCODE-0000  MEDIA IDENTIFIER-0073  FORMAT IDENTIFIER-00
 * EXCEPTION 00
 * REFERENCE MEDIA MAINTENANCE PROCEDURE 00

VOLUME-JANZ99  DEVICE-08A9  DATE-023/90  TIME-15:35:30:19
 * D/T-3590/3490EMU     S/N 0113-23456
 * SERIOUS ALERT        REFCODE-0000  MEDIA IDENTIFIER-0073  FORMAT IDENTIFIER-00
 * EXCEPTION 00
 * REFERENCE MEDIA MAINTENANCE PROCEDURE 00

VOLUME-SL0001  DEVICE-0DC1  DATE-297/07  TIME-08:39:56:05
 * D/T-3592-E06          S/N 0000-00000
 * SERVICE ALERT        REFCODE-1011  MEDIA IDENTIFIER-0120  FORMAT IDENTIFIER-01
 * EXCEPTION 10
 * REFERENCE MESSAGE CODE 10
```

Figure 12. TAPE Media Informational Messages (MIMs)

---

## Chapter 24. JES3 modifications for TS1130 tape drive

JES3, a z/OS MVS subsystem, manages resources and work flow before and after jobs are processed. You can enable JES3 to allocate TS1130 (3592 Model E06) tape drives and tape volumes in an SMS-managed IBM tape library environment (automated or manual) for 3590 Model B emulation only. To do so, you need to specify at least one of these library device group (LDG) names in your JES3plex. An LDG is a predefined set of tape subsystems within a JES3plex.

### **LDMsssss**

Includes any encryption-enabled 3592 Model E06 devices with the library indicated by serial number sssss.

### **LDGdddd**

Includes any encryption-enabled 3592 Model E06 devices (dddd=359M) in any library in the JES3plex.

See *z/OS JES3 Initialization and Tuning Reference* for additional information on LDGs, JES3, and JES3plex.



---

## Chapter 25. OAM modifications for TS1130 tape drive

The Object Access Method (OAM) is a component of DFSMSdftp. OAM uses the concepts of system-managed storage, introduced by SMS, to manage, maintain, and verify tape volumes and tape libraries within a tape storage environment. You can also use OAM's object support to manage objects on DASD, tape, and optical volumes.

### Related reading:

- See *z/OS DFSMS OAM Planning, Installation, and Storage Administration Guide for Tape Libraries* for additional information about using OAM to manage tape volumes and tape libraries.
- See *z/OS DFSMS OAM Planning, Installation, and Storage Administration Guide for Object Support* for additional information about using OAM to manage the data on tape volumes.
- See *z/OS MVS System Messages, Vol 4 (CBD-DMO)* for explanations and appropriate actions for CBRxxxxx messages.

---

## OAM library support

OAM uses the concepts of system-managed storage, introduced by SMS, to manage, maintain, and verify tape volumes and tape libraries within a tape storage environment. This topic describes the OAM library support functions that have been changed for use with the TS1130 tape drives. The enhancements include support for two new recording formats, EFMT3 and EEFMT3.

These steps should be considered when planning to use the new 3592-3E drives:

1. Define the new devices using HCD.
2. Modify your ACS routines to select tape storage groups and libraries with 3592 Model E06 (3592-3E) devices.
3. Add, as appropriate, data classes to use EFMT3 and EEFMT3 on the new 3592-3E drives.
4. Specify, as appropriate (for the EEFMT3 recording format), the key labels and encoding mechanism for each label.
5. Specify, as appropriate, the read-compatible special attribute indicator for EFMT1 formatted volumes. OAM will use the read-compatible special attribute indicator (TDSPEC) in the tape configuration database (TCDB) or usage of the LABEL=(,,IN) on the DD statement of JCL to determine if an EFMT1 formatted volume is eligible to be read by a 3592-3E device.
6. Contact your tape management system vendor to obtain their support and any modified installation exits.

## LCS external services changes

External Services supports the TS1130 tape drive media types, MEDIA5, MEDIA6, MEDIA7, MEDIA8, MEDIA9, and MEDIA10, and the new recording technologies EFMT3 and EEFMT3. It also supports, for media interchange, the older recording technologies EFMT1, EFMT2 and EEFMT2. Also, remember that the TS1130 (3592 Model E06) tape drive can only read the EFMT1 recording format and, as

previously indicated, only if the read-compatible special attribute indicator is set, will a 3592-3E device be considered eligible for an EFMT1 formatted volume. The following functions are supported:

- Change use attribute
- Query volume residence
- Test volume eligibility
- Eject a volume
- Manual cartridge entry

**Note:**

- The MEDIA5, MEDIA6, MEDIA7, and MEDIA8 media types are valid with the EFMT1, EFMT2, EEFMT2, EFMT3, and EEFMT3 recording technologies.
- The MEDIA9 and MEDIA10 media types are valid only with the EFMT2, EEFMT2, EFMT3, and EEFMT3 recording technologies.
- In general, in an environment sharing the TCDB at different software levels, if a lower-level system without appropriate support attempts to perform one of the CBRXLCs functions using a volume that has EFMT3 or EEFMT3 recording technology, the request fails with existing return code LCSFAIL (12) and existing reason code LCSFNSUP (310).

## OAM installation exits changes

These installation exits support EFMT3 and EEFMT3 recording technology:

- Change use attribute (CBRUXCUA) installation exit: Tape recording technology fields have been updated with EFMT3 and EEFMT3.
- Cartridge entry (CBRUXENT) installation exit: Tape recording technology fields have been updated with EFMT3 and EEFMT3.
- Cartridge eject (CBRUXEJC) installation exit: Tape recording technology fields have been updated with EFMT3 and EEFMT3.
- Volume not in library (CBRUXVNL) installation exit: Tape recording technology fields have been updated with EFMT3 and EEFMT3. For additional information regarding this exit, refer to “Volume not in library installation exit enhancement” on page 332.

## Operator command support changes

Volumes with EFMT3 and EEFMT3 recording technology are only displayed on systems with full TS1130 tape drive support installed.

These operator tasks have been changed in support of the TS1130 tape drive.

- The DISPLAY SMS,VOLUME command displays the new EFMT3 and EEFMT3 recording technology, as appropriate, in the output display for CBR1180I (OAM tape volume status).
- The LIBRARY DISPDRV command displays 3592-3E for the TS1130 tape drive in the output display for CBR1220I (Tape drive status).
- The LIBRARY SETCL command allows MEDIA5, MEDIA6, MEDIA7, MEDIA8, MEDIA9, and MEDIA10 to be set for a TS1130 tape drive that supports a cartridge loader.

## Mount processing change

A TS1130 (3592 Model E06) tape drive is able to read in the five 3592 recording formats (EFMT1, EFMT2, EEFMT2, EFMT3, and EEFMT3), but can only write in four of the recording formats (EFMT2, EEFMT2, EFMT3, and EEFMT3). For a DISP=OLD request (or DISP=MOD treated as OLD), preference is given to the

lower technology devices first. For an EFMT2 recorded volume, preference is given to the base Model E05 and then to the encryption-capable 3592 Model E05 and then to the 3592 Model E06. For an EEFMT2 request, preference is given to the encryption-capable 3592 Model E05, and then to the 3592 Model E06.

If the read-compatible special attribute indicator is enabled for an EFMT1 formatted volume, preference is given to the 3592 Model J1A, followed by the 3592 Model E05, then the encryption-capable 3592 Model E05, and then the 3592 Model E06. OAM will use the read-compatible special attribute indicator (TDSSPEC) in the tape configuration database (TCDB) or usage of the LABEL=(,,IN) on the DD statement of JCL to determine if an EFMT1 formatted volume is eligible to be read by a 3592 Model E06 device. If the read-compatible special attribute is not set for an EFMT1 volume, preference is given to the 3592 Model J1A, then the 3592 Model E05, and then the encryption-capable 3592 Model E05.

For a DISP=NEW request, a TS1130 tape drive is considered eligible for an EFMT2 or EEFMT2 request, as well as for the new EFMT3 and EEFMT3 requests. If a media type is not specified, for an EFMT3 or EEFMT3 scratch request, the preference is MEDIA9 followed by MEDIA5 and then MEDIA7, enabling the higher capacity cartridges to be selected first.

## OAM macro changes

Table 42 on page 253 describes changes to OAM mapping macros and installation exit parameter lists in support of TS1130 tape drives.

Table 26. OAM mapping macro changes

The macro	that maps	has these changes.
CBRTDSI	the tape device selection information (TDSI)	TDSEFMT3 EQU 9 READ/WRITE ON ENTERPRISE * FORMAT 3 (EFMT3) DEVICE TDSEEFMT3 EQU 10 READ/WRITE ON ENTERPRISE * ENCRYPTED FORMAT 3 (EEFMT3) DEVICE
CBRTVI	the tape volume information	TVIEFMT3 EQU 9 READ/WRITE ON ENTERPRISE * FORMAT 3 (EFMT3) DEVICE TVIEEFMT3 EQU 10 READ/WRITE ON ENTERPRISE * ENCRYPTED FORMAT 3 (EEFMT3) DEVICE
CBRUXCPL	the change use attribute installation exit parameter list	UXCEFMT3 EQU 9 READ/WRITE ON ENTERPRISE * FORMAT 3 (EFMT3) DEVICE UXCEEFT3 EQU 10 READ/WRITE ON ENTERPRISE * ENCRYPTED FORMAT 3 (EEFMT3) DEVICE
CBRUXEPL	the cartridge entry installation exit parameter list	UXEEFMT3 EQU 9 READ/WRITE ON ENTERPRISE * FORMAT 3 (EFMT3) DEVICE UXEEEFMT3 EQU 10 READ/WRITE ON ENTERPRISE * ENCRYPTED FORMAT 3 (EEFMT3) DEVICE
CBRUXJPL	the cartridge eject installation exit parameter list	UXJEFMT3 EQU 9 READ/WRITE ON ENTERPRISE * FORMAT 3 (EFMT3) DEVICE UXJEEFMT3 EQU 10 READ/WRITE ON ENTERPRISE * ENCRYPTED FORMAT 3 (EEFMT3) DEVICE
CBRUXNPL	the volume not in library installation exit parameter list	UXNEFMT3 EQU 9 READ/WRITE ON ENTERPRISE * FORMAT 3 (EMFT3) DEVICE UXNEEFMT3 EQU 10 READ/WRITE ON ENTERPRISE * ENCRYPTED FORMAT 3 (EEFMT3) DEVICE

## Cartridge entry processing

When a volume is entered into an IBM automated or manual tape library, the cartridge entry installation exit (CBRUXENT) is invoked to approve or deny an enter request, and to set or verify the recording technology to be associated with a volume.

If a volume TCDB record does not exist for the entry of a private MEDIA5, MEDIA6, MEDIA7, or MEDIA8 volume and there is no applicable recording technology being provided by the library's entry default data class, EFMT1 is passed to the exit. If the exit returns with a recording technology for a MEDIA5, MEDIA6, MEDIA7, or MEDIA8 volume, and it is not EFMT1, EFMT2, EEFMT2, EFMT3, or EEFMT3, the specification is considered invalid, and the exit is disabled.

If a volume TCDB record does not exist for the entry of a private MEDIA9 or MEDIA10 volume, and there is no applicable recording technology being provided by the library's entry default data class, EFMT2 is passed to the exit. If the exit returns with a recording technology for a MEDIA9 or MEDIA10 volume and it is not EFMT2, EEFMT2, EFMT3, or EEFMT3, the specification is considered invalid and the exit is disabled.

If a volume TCDB record does not exist for the entry of a private MEDIA 5, MEDIA6, MEDIA7, MEDIA8, MEDIA9, or MEDIA10 volume and the volume is being entered as a scratch volume, UNKNOWN will be passed to the exit and will be assigned when the volume is used during job processing.

If a TCDB volume record exists and the volume's recording technology or media type is not supported on the system processing the volume, in an ATLDS, the volume is left in the library manager insert category to be processed by a system with appropriate support.

The cartridge entry installation exit (CBRUXENT) is passed via register 1, the pointer to a parameter list mapped by CBRUXEPL.

---

## OAM object tape support

In a stand-alone environment, the SETOAM TAPEUNITNAME parameter in the CBROAMxx member of PARMLIB can be specified using an esoteric that contains TS1130 (3592-3E) tape drives. In the stand-alone environment, 3592 Model J, 3592 Model E05 (not encryption capable), 3592 Model E05 (encryption capable), and 3592 Model E06 drives need to be segregated in their own unique esoteric in order to prevent allocating a 3592-J, 3592-2, or 3592-2E drive for a volume written with EFMT3 or EEFMT3 recording technology, because EFMT3 and EEFMT3 are only compatible with 3592-3E drives. In an IBM tape library environment, the SETOAM DATACLASS parameter at the storage group (or global level) can be used to specify a desired recording technology and ensure allocating an appropriate drive.

The ERDS Physical ID (EPI) value for the 3592-3E drive is a hex '14' and is stored in the DB2 TAPEVOL table of the OAM Optical Configuration Database (OCDB) for a volume written in EFMT2, EEFMT2, EFMT3, or EEFMT3 by a 3592-3E drive, and displayed, as appropriate, in the volume display.

## KB Tracking

Today, OAM's object support records the following values in the DB2 TAPEVOL table in kilobytes:

- The capacity of the tape volume.



- The free space on the tape volume.
- The number of logical bytes written to a tape volume.
- The number of physical bytes written to a tape volume.
- The number of logical bytes deleted from a tape volume.

These fields have the potential to overflow their existing FIXED(31) fields using current capacities, especially those that deal with logical KBs. To resolve the potential overflow of these fields in the DB2 TAPEVOL table, five new columns will be added that are FIXED(31) fields (using INTEGER) to account for the number of overflow KBs (in 2GB increments). The overflow field will indicate the number of times the existing FIXED(31) field overflows and 64-bit arithmetic will be used in the calculations and in storing the overflow information. For example:

- A tape volume has 2147983647 KB logically written to it. This value is more than a FIXED(31) field will hold in KBs, which is 2147483647.
- Dividing the KB written by 2GB (2147483648) will result in the number of overflow KBs (in 2GB increments) as well as the remainder resulting from the division. In this example, the overflow value will be 1 and the remainder from the division will be 499,999:

$2147983647 / 2147483648 = 1$  with a remainder of 499,999

- The current column in the DB2 TAPEVOL table that represents the amount of data logically written to the tape volume in KB will be 499,999.
- To determine the amount of data on the tape volume (in KB) for the existing DB2 TAPEVOL table fields that have overflow potential (CAPACITY, FRESpace, NUMLKBW, NUMPKBW and NUMLKBDE), verify there is a value in the associated overflow field (CAPACITYO, FRESpaceO, NUMLKBWO, NUMLKPWO and NUMLKBDEO):
  - If there is no value in the associated overflow field, the value in the existing field represents the total number of kilobytes.
  - If there is a value in the associated overflow field, multiply the overflow value that is associated with the amount of data logically written to the tape volume by 2GB (2147983648) and then add the result of the multiplication to the value in the current FIXED(31) field that represents the amount of KB logically written to the tape volume.
- The new overflow column that represents the number of 2GB's written to the tape volume will be 1.

The D SMS,VOL(*volser*) operator command output will be modified to display the tape capacity in KB followed by a 'K' if the capacity is less than 2GB, and will display the capacity in MB followed by an 'M' if the capacity is equal to or greater than 2GB. Messages that report on the KB values as message inserts are updated. IPCS modifications reflect new fields that are added to OAM macros as a result of this support. New sample members are added to the new DB2 overflow-related columns in the DB2 TAPEVOL table.

When inspecting the capacity and free space displayed via the D SMS,VOL(*volser*) operator command, if the capacity or free space is less than 2GB, it will be displayed in KB followed by a 'K'. If the capacity or free space is equal to or greater than 2GB, it will be displayed in MB, followed by an 'M'.

## Sample Jobs

A new DB2<sup>®</sup> migration job, CBRSMKBO, is added to the existing TAPEVOL table, as well as updates to CBR SAMPL, to add KB overflow columns.

## CBRSMKBO

```
//CBRSMKBO JOB MSGLEVEL=(1,1),MSGCLASS=A
//*****
//*
//* $SEG(SMKBO) COMP(DBM) PROD(OAM):
//*
//* OAM DB2 Database Migration Job (for OAM TAPEVOL table).
//*
//* CBRSMKBO
//*
//* This job performs the migration of the TAPEVOL table to the
//* new version of the TAPEVOL table supporting the new 3592-3E tape
//* capacity. The new capacity may overflow existing fields that track KB of
//* data on tape volumes. The new columns will contain overflow values that
//* will allow the larger tape capacities to be used.
//*
//* This job will:
//* 1. Add 5 new columns to the existing TAPEVOL table: The columns
//* are:
//* 1. CAPACITYO - overflow column for tape capacity (CAPACITY).
//* 2. FRESPEAO - overflow column for free space (FRESPEAO).
//* 3. NUMLKBWO - overflow column for Logical KB written (NUMLKBW).
//* 4. NumpKBWO - overflow column for Physical KB written (NumpKBW).
//* 5. NUMLKBDEO - overflow column for Logical KB deleted (NUMLKBDE).
//* 2. Place labels in existing TAPEVOL table for the new columns.
//*
//*
//* It is recommended that you create a DB2 image copy of the
//* existing TAPEVOL table prior to executing this
//* migration job for recovery purposes.
//*
//* Before running this job, you must change the following:
//*
//* 1. Change the name in the DSN SYSTEM(DB2) statement to
//* the name of the DB2 Subsystem in your installation.
//*
//* 2. Change the PLAN name (DSNTIA71) in the RUN statement to
//* match your current DB2 version and release level.
//*
//* 3. Change the data set name in the RUN statement
//* LIB('DB2MINI.V7R1M0.RUNLIB.LOAD') phrase to the data set name used
//* in your installation for the DB2 RUNLIB.LOAD data set.
//*
//*
//* CHANGE ACTIVITY:
//* $L0=xxxxxx xxx YMMDD TUCxxx: Initial Release
//*
//*****
//*****
//* Alter the TAPEVOL table to add the new overflow column definitions
//*****
//ALERTAB EXEC PGM=IKJEFT01,DYNAMNBR=20,COND=(4,LT)
//SYSPRINT DD SYSOUT=*
//SYSTSIN DD *
DSN SYSTEM(DB2)
RUN PROGRAM(DSNTIAD) PLAN(DSNTIA71) -
LIB('DB2MINI.V7R1M0.RUNLIB.LOAD')
//SYSPRINT DD SYSOUT=*
//SYSUDUMP DD SYSOUT=*
//SYSIN DD *

ALTER TABLE TAPEVOL ADD CAPACITYO INTEGER NOT NULL WITH DEFAULT;
ALTER TABLE TAPEVOL ADD FRESPEAO INTEGER NOT NULL WITH DEFAULT;
ALTER TABLE TAPEVOL ADD NUMLKBWO INTEGER NOT NULL WITH DEFAULT;
ALTER TABLE TAPEVOL ADD NumpKBWO INTEGER NOT NULL WITH DEFAULT;
ALTER TABLE TAPEVOL ADD NUMLKBDEO INTEGER NOT NULL WITH DEFAULT;
COMMIT;
/*
//*****
//* Place labels in table for new columns
//*****
//LABELTAB EXEC PGM=IKJEFT01,DYNAMNBR=20,COND=(4,LT)
//SYSPRINT DD SYSOUT=*
//SYSTSIN DD *
DSN SYSTEM(DB2)
RUN PROGRAM(DSNTIAD) PLAN(DSNTIA71) -
LIB('DB2MINI.V7R1M0.RUNLIB.LOAD')
```

---

## Object tape migration considerations

If you choose to encrypt your object data, any partially filled non-encrypted tape volumes associated with an object storage group that you want to encrypt, should be marked full and not writable, so they are not selected. This is important because at the volume level all of the data on the tape is either encrypted or non-encrypted, and a mix of the two cannot reside on the same tape.

In the past, when migrating to a new drive model with a new recording technology using media types that could also be used at a lower-level recording technology, you marked your partially filled volumes as full or not writable and new write requests were done at the new recording technology. Since the 3592 Model E06 is downward write compatible with the 3592 Model E05, this same concern does not exist for EFMT2/EEFMT2; however, since the 3592 Model E06 is not downward write compatible with the EFMT1 format, customers will need to mark any partially filled tapes 'full' or 'not writable' as they migrate to the newer 3592 drive technology and no longer have any devices capable of writing EFMT1.

These items should be considered when planning to use 3592-3E drives:

If the 3592-3E devices are in an IBM tape library:

1. Follow the steps listed in “OAM library support” on page 251 for OAM Library Support.
2. Add new data classes, specifying EFMT3 and EEFMT3 recording technologies.
3. Review ACS routines for STORE, or CTRANS, or both environments for any changes that may be necessary to ensure proper class assignment.

If the TS1130 (3592 Model E06) devices are not in an IBM tape library, use device esoterics for STORAGEGROUP statements in the CBROAMxx member of PARMLIB for the Object storage groups that are to use the new devices. It is important to segregate in an esoteric the different 3592 devices to prevent allocating an inappropriate device for a volume written in the EFMT3 or EEFMT3 recording technology. Add new TAPEUNITNAME with the new device esoteric to the STORAGEGROUP statements in the CBROAMxx PARMLIB member for object storage groups or object backup storage groups that use the new devices.

All partially filled EFMT1 volumes belonging to a storage group with 3592-3E devices assigned need to be marked 'full' or 'not writeable' as the 3592-3E device is not downward write-compatible with the EFMT1 recording format. This will prevent a 3592-3E device from being selected to write an EFMT1 tape volume.

Coexistence and full support systems must have the new NUNPKBWO, NUMLKBWO, NUMLKBDEO, FRESPEAO and CAPACITYO columns added to the TAPEVOL table in the Optical Configuration Database (OCDB). Run the CBRSMKBO DB2 Database Migration sample JCL to add the columns. After the new columns have been added, run CBRPBIND. In an OAMplex, since the DB2 tables are shared, only one system in the OAMplex needs to run CBRSMKBO to add the new TAPEVOL table columns but all the systems in the OAMplex need to run CBRPBIND.

---

## Object tape volume management support

The TS1130 tape drive supports the existing 3592 media types (MEDIA5, MEDIA6, MEDIA7, MEDIA8, MEDIA9, and MEDIA10), including special handling of WORM (MEDIA6, MEDIA8, and MEDIA10) tape volumes that have expired. You cannot recycle WORM tape volumes because they cannot be written from load point.

---

## Chapter 26. MVS IOS support for TS1130 tape drive

MVS IOS support for the TS1130 tape drive is unchanged from that for the TS1120 tape drive. See Chapter 39, “MVS IOS support for TS1120 tape drive,” on page 257 (which has been updated in this edition) for more information.



---

## **Part 3. Encryption-capable TS1120 tape drive**





---

## Chapter 27. Introduction for encryption-capable TS1120 tape drive

Data encryption is an important tool for protecting against the possible misuse of confidential information that could occur should tapes be lost or stolen. Unless the possessor of the tape has the required key, any encrypted data on the tape will remain confidential and will be unreadable.

This topic describes the IBM System Storage encryption-capable TS1120 (3592 Model E05, 3592-2E) tape drives and the z/OS software support needed to use them.

---

### Encryption-capable TS1120 tape drive

All new TS1120 tape drives and any older 3592 Model E05 drives that have been updated by a chargeable field upgrade (Feature Code 5592) are capable of encryption. If the encryption capability is needed, an IBM Customer Engineer must enable the encryption feature of the drives. Drives that do not have the encryption feature enabled will report as today's 3592 Model E05 (3592-2) and when the feature is enabled, will report as (3592-2E). When the encryption feature has been enabled, the host considers the encryption-enabled drives as being encryption-capable. References in this document to "encryption-capable," means that the encryption feature in the drive had been enabled and the drive is capable of encrypting. In other documents, this may be referred to as "encryption-enabled."

The encryption-capable TS1120 tape drive provides, in addition to the ability to read and write encrypted data tapes, the same high capacity, performance, reliability, and host connectivity provided by the non-encryption capable 3592 Model E05 tape drive. Specifically, the encryption-capable TS1120 tape drive offers these features:

- Creates tapes for archive files.
- Optionally creates encrypted tapes.
- Backs up and restores systems in case of system or disk storage problems.
- Stores high-speed, high-capacity sequential application data sets.
- Stores temporary data sets.
- Satisfies off-site data storage for disaster recovery.
- Provides data interchange with other systems that use 3592 Model E05 (TS1120) or 3592 Model J1A subsystems.
- Supports WORM (write once, read many) tape data cartridges whose data cannot be altered.

The advantages of the encryption-capable TS1120 tape drive over other encryption methods, such as host-based software encryption, are that it:

- Permits full performance of the tape device when encryption is enabled.
- Permits encryption to be performed after compression.
- Avoids performance penalties in the host.

---

## Tape encryption for TS1120

The encryption-capable TS1120 tape drive supports encryption of media tape cartridges. The z/OS DFSMS support for tape subsystem encryption allows you to specify by data class that data is to be encrypted when stored on encryption-capable TS1120 tape drives. In addition to this, the key label-related information that is used to encrypt the data key (of a tape cartridge) can be specified through the DD statement (JCL, dynamic allocation and TSO ALLOCATE), data class or Encryption Key Manager component for the Java platform (EKM) defaults. The communication path to the Encryption Key Manager (EKM) is across TCP/IP with the choice to go either in-band or out-of-band for the key management flow. With out-of-band key management, the communication path to the Encryption Key Manager is handled by the control unit going directly to the Encryption Key Manager. Then for in-band key management, the communication path to the Encryption Key Manager is handled across ESCON/FICON with a new IOS proxy interface then handling the key exchange (across TCP/IP) with the Encryption Key Manager.

An encryption-capable TS1120 tape drive records in the existing non-encryption enterprise format 1 (EFMT1) and enterprise format 2 (EFMT2) recording formats and also records in the encryption specific recording format (enterprise encrypted format 2 (EEFMT2)). The EEFMT2 recording format is supported across all of the 3592 media types (MEDIA5 – MEDIA10). Even though the encryption-capable TS1120 tape drive can record in a lower density (EFMT1) and a higher density (EFMT2) recording format, an encrypted version of the lower recording format (EFMT1) is not supported. Only the higher recording format (EFMT2) will be supported with an encrypted version (EEFMT2). The existing Performance Scaling and Performance Segmentation data class options, applicable with MEDIA5 and MEDIA9, can also be used with the new encryption format EEFMT2. The capacities of EMFT2 and EEFMT2 written tapes are the same.

When writing from the beginning of tape (BOT), an encryption-capable TS1120 tape drive will, by default, record in the non-encryption recording format (EFMT2). Depending on the host platform and its encryption enablement mechanism, this default can be changed at the drive. However, under z/OS and OPEN processing (file sequence 1, DISP=NEW), unless explicitly requested through data class to record in the lower recording format (EFMT1) or the new encryption format (EEFMT2), the non-encryption format EFMT2 will be assumed and explicitly set during OPEN processing. When writing from the beginning of the tape (file sequence 1, DISP=OLD), since this processing does not go through the data class ACS routine, OPEN processing will determine if the previous usage of the tape was encrypted and if encrypted, OPEN will explicitly set the EEFMT2 format with the volume's existing key management-related information being used by the drive to encrypt the data.

For an encrypted tape cartridge, the cartridge stores both the encrypted user data and the critical key management-related information needed to interact with the Encryption Key Manager when decrypting data on the cartridge. A mix of data written in encrypted and non-encrypted formats is not supported on the same tape cartridge. Whether the data on a cartridge is written in encrypted format is determined during OPEN processing, when the first file sequence on the tape is written. If the first file written to a tape is in the encrypted format; all subsequent files written to that same tape cartridge will be written in the encrypted format. All files written to a cartridge in the encrypted format are encrypted using the same data key. The exception to this is the volume label structure for the first file

sequence, which is encrypted using a key known to all encryption capable 3592 drives, which means it is effectively in the clear.

In the encryption-capable TS1120 tape drive environment (whether system-managed or not), when writing from the beginning of tape (file sequence 1, DISP=NEW), to request encryption format, EEFMT2 is specified in data class. OPEN processing passes key management-related information (such as the key labels) to the drive for subsequent communication with the Encryption Key Manager.

To select encryption for a cartridge, do these steps:

1. Define a data class that requests encryption.
2. Modify or create ACS routines to associate the tape output functions using encryption with a data class that requests encryption.
3. Specify the appropriate key labels either through the DD statement (JCL, dynamic allocation, or TSO allocate), data class, or by using Encryption Key Manager established defaults.

---

## Key management for TS1120

Key Management consists of a number of elements including:

- A key store where the keys to encrypt and decrypt the data key are securely kept and readily available.
- An Encryption Key Manager (EKM) that communicates with the drive through the designated key management path (in-band or out-of-band).
- Ability of the tape drive to request and process (with the Encryption Key Manager) key management information.
- A management interface for configuring and managing the Encryption Key Manager (EKM).

## Key store for TS1120

A key store is where the keys (to encrypt and decrypt the data key) are securely kept such that they are available when data needs to be encrypted or decrypted. The Encryption Key Manager uses Java APIs to retrieve and store the key information. The Encryption Key Manager (EKM) allows for the use of hardware or software based key stores that are JCE compliant. In this first release of the Encryption Key Manager, these key stores are supported under z/OS: JCEKS, JCERACFKS, JCE4758KS (JCECCAKS), JCE4758RACFKS (JCECCARACFKS). The first two key stores are software based and the last two are hardware based. The hardware based key stores under z/OS then have a tie to the existing z/OS Integrated Cryptographic Service Facility (ICSF). In addition to the key stores above, these key stores are also available if the key store resides outside of z/OS (in the distributed environment): JCEKS, IBMi5OSkeystore, and PKCS11IMPLKS. The first two key stores are software based and the last one is hardware based. When multiple key stores are available on the system, you may configure which key store to use. The key store can also take advantage of hardware for protecting keys so that the keys are always protected under the hardware master key and the key values never appear in the clear in system memory. Access control to the key store is controlled by z/OS access controls.

## Encryption Key Manager (EKM) for TS1120

For an encrypted tape cartridge, the cartridge stores not only the encrypted user data, but also critical key management-related information needed to interact with

the Encryption Key Manager (EKM). The Encryption Key Manager (EKM) communicates over TCP/IP connections with the tape drive (in-band or out-of-band) to provide the key information required by the tape drive to encrypt or decrypt the data. This TCP/IP connection needs to be secure, and the security can be achieved either by physical security or with IP security protocols, such as VPN. The method for securing this TCP/IP connection relies on existing system capabilities and is outside the scope of the key management system.

The Encryption Key Manager (EKM) is a common platform application written in JAVA that runs under the Java Virtual Machine (JVM). The EKM then interfaces with an existing key store, which under z/OS may be one of the hardware based key stores (JCE4758KS (JCECCAKS) or JCE4758RACFKS (JCECCARACFKS)) that work with the Integrated Cryptographic Service Facility (ICSF), or it may be one of the software based key stores (JCEKS or JCERACFKS). If the EKM resides outside of the z/OS environment, then the JCEKS and IBMi5OSkeystore software based key stores or the PKCS11IMPLKS hardware based key store may be used.

When the encryption capable tape drive needs a key to perform an encrypted write, a data key is generated by the EKM. The data key used to encrypt the data on a tape cartridge is itself encrypted (using the public key of a public/private key pair) with either one or two key encrypting keys (KEKs) stored in the key stores. The KEKs are maintained by the EKM through an existing key store and are pointed to by the appropriate KEK label, also referred to as the key label. The EEDKs are then passed from the EKM to the drive and stored in the tape cartridge. The drive cannot decrypt the EEDKs (it can only store them), so the data key it is to use for decryption is also passed to the drive in another encrypted form that the drive can decrypt. On a subsequent mount of the cartridge, the drive passes the EEDKs to the EKMs so the Encryption Key Manager can extract the data key that was used. The EKM then passes that data key back to the drive in another encrypted form the drive can decrypt. The EEDKs can only be decrypted by an Encryption Key Manager that is connected to a key store that possesses the right key information (the private keys associated with the KEK labels).

You may use multiple encrypting tape drives and configure a single key management server to be used across these tape drives. Conversely, for redundancy, an encrypting tape drive may be configured to communicate with more than one tape key management server (both a primary and a secondary key management server). In this case, both key management servers are assumed to be capable of handling key requests from the tape drive. This implies that the key management servers are configured identically and are using the same set of public/private key pair information to encrypt and decrypt the data key.

When writing from load point, if two different key labels are specified, both key labels must be defined to the key store and accessible to the Encryption Key Manager (EKM). This ensures that both EEDK structures can be properly built by the EKM and stored on the tape cartridge. When reading a volume, only one of the two EEDK structures previously stored on the tape cartridge needs to be able to be unwrapped by the Encryption Key Manager. As part of this process the EKM will communicate with the key store to unwrap the encrypted data key stored on the cartridge in the EEDK structure.

The encoding mechanism (label or public key hash), provides instructions that the Encryption Key Manager (EKM) will use to build the EEDKs that are stored on the tape cartridge. The "Label" encoding mechanism indicates that the key label itself is to be stored as part of the EEDK structure on the tape cartridge, whereas the "public key hash" encoding mechanism indicates that a hash of the public key

referenced by the key label is to be stored on the cartridge rather than the key label itself. Storing the hash value rather than the key label itself allows for greater flexibility when tape cartridges are exported to another location, especially if that location may be using a different key label (than the originating site) to refer to the same key.

The role of DFSMS and policy management is to indicate to the drive, during OPEN processing (file sequence 1, DISP=NEW) that the mounted tape volume is to be encrypted (as indicated through the SMS data class policy and the specification of EEFMT2 for the recording format). OPEN processing will also pass to the drive critical key management-related information such as the key encrypting key (KEK) labels and the encoding mechanism (label or public key hash) specified through data class or through the DD statement (JCL, dynamic allocation or TSO ALLOCATE). The values specified through the DD statement will override any data class specification. If the key-management-related information is not specified through the DD statement or data class, Encryption Key Manager established defaults will be used that can be specified on both a global and a drive level.

The drive's request for the data key and the passing of key management-related information can be done in-band between the drive and the Encryption Key Manager (through the control unit and host across ESCON/FICON) or it can be done out-of-band (through the control unit across TCP/IP). However, because the Encryption Key Manager (EKM) only has a TCP/IP interface, in-band communication to the EKM is handled by a new z/OS proxy interface. The proxy interface receives the request from the drive across ESCON/FICON and then interfaces with the established EKM for that system across TCP/IP. The z/OS proxy then communicates back to the drive (through the control unit across ESCON/FICON) providing the key management-related information that the drive needs. Under z/OS, the recommended communication path to the EKM is in-band across ESCON/FICON under the same system that initiated the read or write request. The EKM itself, however, can reside on that same z/OS system, on another z/OS system, or even on another platform's server. Out-of-band key management, from the control unit across TCP/IP, can be used to communicate with an EKM running under a z/OS system or somewhere else. By default, the control unit will use out-of-band key management unless otherwise changed by default or by explicit host command. With the interface to the EKM being across TCP/IP, you have, based on your TCP/IP infrastructure and key management requirements, a number of different configuration options available, for both in-band and out-of-band key management. If in-band key management is to be used, the existing IOS PARMLIB member IECIOSxx (or the SETIOS EKM command) must be updated to specify the TCP/IP-related information needed to direct the z/OS proxy to the desired Encryption Key Manager (primary and secondary).

## **In-band proxy for TS1120**

The in-band z/OS proxy allows key management information to be exchanged with a tape drive over existing ESCON/FICON, instead of requiring the deployment of a secondary IP network. The reliability and physical security of the existing I/O attachments is one reason that you may choose to use the in-band key management path to the Encryption Key Manager. The z/OS proxy interface communicates with the tape drive (through the control unit) in the current data path and then uses a TCP/IP connection to communicate with the Encryption Key Manager.

**Note:** APAR OA22271 added support for IPv6. This support was added after the initial tape encryption support for the TS1120.

## Management interfaces for TS1120

You will need to configure whether to use a direct TCP/IP connection between the storage devices and the Encryption Key Manager (out-of-band) or configure to use the in-band proxy. Under z/OS the in-band proxy is defined using the IECIOSxx PARMLIB member (or the SETIOS EKM command).

For z/OS tapes, you can configure whether to encrypt or not based on data class definitions. Furthermore, for z/OS you may specify the key labels through data class or through the DD statement (JCL, dynamic allocation, or TSO ALLOCATE). In addition to this, Encryption Key Manager assigned defaults can also be used if the key labels are not provided through z/OS.

For tapes that will be encrypted or decrypted, you must define and keep track of the key information to be used. For information on key management and the role of the Encryption Key Manager (EKM), refer to *IBM System Storage Tape Encryption Key Manager, Introduction, Planning, and User Guide*, GA76-0418.

---

## Key label specifications for TS1120

When the first file sequence on a tape is written and encryption is requested, up to two key encrypting key (KEK) labels can be specified, enabling the data key to be encrypted with two different keys. One of the keys may be used for local (on-site) usage and the second may be used for export (off-site) purposes.

**Note:** When the specified key labels are being used for export purposes, remember that the encryption key manager requires that at least one of the key encrypting key (KEK) labels specified has to have a private key associated with it. This allows the creator of the tape to also decrypt the data key (and the data) in case of an emergency.

Key label specifications can be specified by:

- Data class (using new ISMF panel fields)
- DD statement (JCL or dynamic allocation, using new keywords KEYLABL1, KEYENCD1 and KEYLABL2, KEYENCD2)
- TSO ALLOCATE command (using new keywords KEYLABL1, KEYENCD1 and KEYLABL2, KEYENCD2)

However specified, key label specifications consist of either one or two key labels, and their associated encoding mechanisms. The *key label* specifies the label for the key encrypting key used by the Encryption Key Manager. The key encrypting key is used to encrypt the data encryption key. The *encoding mechanism* specifies how the label for the key encrypting key specified by the key label (input) is encoded by the Encryption Key Manager and stored on the tape cartridge. The two encoding mechanisms are:

- H the label for the key encrypting key is to be encoded as a hash of the public key
- L the label for the key encrypting key is to be encoded as the specified label

### Rules for key labels:

1. Specification of the key labels are optional and are only applicable with DISP=NEW, file sequence 1 and are otherwise ignored. If the key labels are not

specified, either through the DD statement or through data class, externally specified Encryption Key Manager defaults will be used.

2. Specification of the key labels does not by itself enable encryption. Encryption must be enabled by a data class that specifies the encryption format EEFMT2. Whether the data on a tape cartridge is encrypted or not is then determined when an encryption capable device is allocated and the first file sequence on the tape is written.

**Note:** In the system-managed environment, specification of the encryption format EEFMT2 will not only request that the encryption format be used, but will also steer allocation to an encryption capable device. In the stand-alone (non-system managed) environment, encryption capable devices must be specified through the UNIT parameter to ensure that an encryption capable device is allocated, with specification of the encryption format EEFMT2 then being used to request the encryption format.

3. One or both key labels may be specified. If a key label is specified, then its encoding mechanism must also be specified and if an encoding mechanism is specified, then its corresponding key label must also be specified. If only one key label is specified, specification of key label 1 or key label 2 is allowed; it doesn't have to be specified as key label 1.
4. If only one key label is specified, the same key label and encoding mechanism is used to generate both EEDKs that are stored on the tape.
5. The key labels must come from the same source; either the DD statement, data class, or the externally specified Encryption Key Manager defaults. The key labels specified on the DD statement will override the key labels specified through data class which will then override any externally specified Encryption Key Manager defaults.
6. The key label can be up to 64 characters, with blanks padding the field on the right. The character string supported is a subset of EBCDIC code page 037. The characters supported are those that map to the portable ASCII characters represented in international standard ISO 646-IRV (US ASCII), which includes numeric, alphabetic, national, and special characters, along with additional punctuation-type characters. National variants of ISO 646 provide for internationalization of the character string. ISO 646-IRV (US ASCII) is a subset of ISO 8859-1 (Latin Alphabet No. 1). The translation from EBCDIC to ASCII and syntax validation of the character string specified occurs at the control unit, and as such, the character set supported stays within the boundaries of 7-bit ASCII and can be successfully handled by the Encryption Key Manager and key store, which both use UTF-8 encoding. From a host perspective, the key label is considered a free form field (binary token) with no validation checking other than to remove leading blanks. The key label syntax is not validated until it is sent to the control unit on a mount request using the specified key label with the control unit then removing trailing blanks. The specified alphabetic characters will be treated as case insensitive by the key store and, therefore, in order for key labels to be unique, they should differ by more than just their case. Refer to the key store documentation and the tooling available for creating the key labels for any additional requirements or restrictions.

---

## Volume label support for TS1120

With the exception of the volume label structure for the first file sequence, all data on a tape cartridge will be encrypted under the same data key. The volume label for the first file sequence (IBM standard tape label (SL) or ANSI standard label (AL)) will be encrypted using a key known to all encryption capable 3592 drives. Circumstances may arise where you no longer know what key encrypting keys

(KEKs) were used to encrypt the data key that is stored on a tape cartridge. Without this knowledge, the externally encrypted data keys (EEDKs) cannot be unwrapped and without the data key, the data itself cannot be decrypted. To help with this situation, z/OS (during OPEN processing), will request that the drive use a key known to all encryption capable 3592 drives when writing all recognized volume label records (VOL1, HDR1, HDR2, and so on). Even though the volume label, for the first file sequence, is still encrypted on the tape cartridge, by using a key known to all encryption capable 3592 drives, the volume label information can be decrypted and returned without going through the Encryption Key Manager (for example, by using an existing utility such as DITTO). Knowing the volume label information can then help to determine what key labels were used. Perhaps you used a unique key label for a particular application or for a particular data set name. Having this information available enables the volume label information to be read while still protecting the encrypted data on the tape cartridge.

---

## Volume recovery for TS1120

Events can occur where there is a need to recover data located beyond the logical end-of-data (EOD) mark of a tape cartridge. For example, a volume that was accidentally scratched and is now being reused from the beginning of tape (BOT). When this happens with unencrypted data, you can sometimes use a recovery utility to try to salvage as much of the remaining data on the tape as possible. With encrypted data, access to the previous set of keys (EEDK structures) is critical to this recovery process. Because saving the existing EEDK structures on the tape could introduce a security exposure, the default operation of the drive is to destroy the existing EEDK structures on the tape. When the EEDKs have been destroyed, encrypted data cannot be recovered beyond the newly written EOD mark. However, any data previously written in a non-encrypted format that was not overwritten with encrypted data is still potentially recoverable.

---

## Re-keying support for TS1120

When the first file sequence on a tape is written and encryption is requested, up to two key encrypting key (KEK) labels can be specified enabling the data key (DK) to be encrypted with two different keys. One of the keys may be used for local (on-site) usage, and the second may be used for export (off-site) purposes. A mechanism is being provided through the drive and the encryption key manager (EKM) that will enable the data key (DK) to be re-encrypted with new key encrypting keys (using new key labels), generating new EEDKs. This enables a tape cartridge to be re-keyed without having to rewrite the data to another volume.

**Note:** z/OS support for re-keying is provided by APAR OA20076. Re-keying is initiated through the IEHINITT utility with a new REKEY option.

---

## Media support for encryption-capable TS1120 tape drives

The encryption-capable TS1120 tape drive reads and writes in the new recording format EEFMT2 (enterprise encrypted format 2), as well as EFMT1 (enterprise format 1) and EFMT2 (enterprise format 2). EEFMT2 records data in an encrypted format. EEFMT2 provides the same capacity as EFMT2. The IBM System Storage encryption-capable TS1120 tape drive uses these IBM System Storage family of tape media:

- MEDIA5 - The IBM TotalStorage Enterprise Tape Cartridge (MEDIA5) physical media. Provides an uncompressed capacity of 500 GB with EFMT2 or EEFMT2



(300 GB with EFMT1) and compressed capacity of 1500 GB with EFMT2 or EEFMT2 (900 GB with EFMT1) assuming a 3:1 compression ratio, depending on the type of data written.

- MEDIA6 - The IBM TotalStorage Enterprise WORM Tape Cartridge (MEDIA6) physical media. Provides an uncompressed capacity of 500 GB with EFMT2 or EEFMT2 (300 GB with EFMT1) and compressed capacity of 1500 GB with EFMT2 or EEFMT2 (900 GB with EFMT1) assuming a 3:1 compression ratio, depending on the type of data written.
- MEDIA7 - The IBM TotalStorage Enterprise Economy Tape Cartridge (MEDIA7) physical media. Provides an uncompressed capacity of 100 GB with EFMT2 or EEFMT2 (60 GB with EFMT1) and compressed capacity of 300 GB with EFMT2 or EEFMT2 (180 GB with EFMT1) assuming a 3:1 compression ratio, depending on the type of data written.
- MEDIA8 - The IBM TotalStorage Enterprise Economy WORM Tape Cartridge (MEDIA8) physical media. Provides an uncompressed capacity of 100 GB with EFMT2 or EEFMT2 (60 GB with EFMT1) and compressed capacity of 300 GB with EFMT2 or EEFMT2 (180 GB with EFMT1) assuming a 3:1 compression ratio, depending on the type of data written.
- MEDIA9<sup>1</sup> - The IBM TotalStorage Enterprise Extended Tape Cartridge (MEDIA9) physical media. MEDIA9 requires the EFMT2 or EEFMT2 recording format, and provides an uncompressed capacity of 700 GB and compressed capacity of 2100 GB assuming a 3:1 compression ratio, depending on the type of data written.
- MEDIA10<sup>1</sup> - The IBM TotalStorage Enterprise Extended WORM Tape Cartridge (MEDIA10) physical media. MEDIA10 requires the EFMT2 or EEFMT2 recording format, and provides an uncompressed capacity of 700 GB and compressed capacity of 2100 GB assuming a 3:1 compression ratio, depending on the type of data written.

You can use the encryption-capable TS1120 tape drive in the stand-alone environment or the tape library environment (automated or manual). Currently, the encryption-capable TS1120 tape drive does not have a cartridge loader.

Support for the encryption-capable TS1120 tape drive will be provided at z/OS V1R4<sup>2</sup> and later releases, however support for MEDIA9 and MEDIA10 requires z/OS V1R5 or later releases. Support for the encryption-capable TS1120 tape drive will be delivered in multiple stages with support for z/OS V1R6 and V1R7 being available first (refer to enabling APAR OA15685). For z/OS V1R8, refer to enabling APAR OA17562 and for z/OS V1R4 and V1R5, refer to enabling APAR OA18111.

Software support of the new media, MEDIA9 and MEDIA10, is available with the support of the encryption-capable TS1120 tape drive, however the media itself will be available at a later GA.

**Note:**

1. If no recording technology has been specified for MEDIA5, MEDIA6, MEDIA7, MEDIA8, MEDIA9, or MEDIA10, EFMT2 is the default recording technology. If EFMT1, EFMT2, or EEFMT2 is needed for interchange purposes, it can be specified through data class. This applies to both the stand-alone and to the system-managed tape library environments.

---

1. Software support of the new media, MEDIA9 and MEDIA10, is available with the support of the 3592 Model E05, however the media itself will be available at a later GA.

2. Support for the encryption-capable TS1120 tape drive will be provided at z/OS V1R4 with the z/OS V1R4 z990 exploitation support feature installed, or at OS.e V1R4 with the z/OS.e V1R4 z990 coexistence update feature installed.

2. To enable the EEFMT2 formatted cartridges to be relabelled/reused from load point on a 3592 Model J1A (3592-1) or an existing 3592 Model E05 (3592-2), drive microcode updates are required on these drives. This is particularly important in a system-managed tape library environment, because common scratch pools are used across the media types.
3. For an encrypted tape cartridge, the cartridge stores both the encrypted user data and the critical key management-related information needed to interact with the Encryption Key Manager when decrypting data on the cartridge. A mix of data written in encrypted and non-encrypted formats is not supported on the same tape cartridge. Whether the data on a cartridge is written in encrypted format is determined during OPEN processing, when the first file sequence on the tape is written. If the first file written to a tape is in the encrypted format; all subsequent files written to that same tape cartridge will be written in the encrypted format. All files written to a cartridge in the encrypted format are encrypted using the same data key. The exception to this is the volume label structure for the first file sequence, which is encrypted using a key known to all encryption capable 3592 drives, which means it is effectively in the clear.
4. The encryption-capable TS1120 tape drive optionally provides performance scaling by using only 20 percent of the full capacity on a MEDIA5 or MEDIA9 cartridge. The default is to use the cartridge's full capacity. The performance scaling option is not available on MEDIA6, MEDIA7, MEDIA8, or MEDIA10 tape cartridge media.
5. The encryption-capable TS1120 tape drive optionally provides performance segmentation. Performance segmentation divides the cartridge into a fast access segment and a slower access segment. The fast access segment will be filled first, after which the slower segment will be filled. This option is available on MEDIA5 and MEDIA9 tapes, but is not available on MEDIA6, MEDIA7, MEDIA8, or MEDIA10 tape cartridge media. The performance segmentation option is mutually exclusive with the performance scaling option.
6. The encryption-capable TS1120 tape drive emulates only 3590 Model B1x tape drives (all 3592 tape cartridge media are supported in this emulation mode) in the standalone and in the system-managed tape library environment (manual or automated).
7. The encryption-capable TS1120 tape drive is supported by the 3592 Model J70 and C06 tape controllers, with either ESCON or FICON attachment.
8. The encryption-capable TS1120 tape drive coexists with 3490E, 3590, and 3592 Model J1A, and the non-encryption capable 3592 Model E05 devices in the 3494 automated tape library.
9. The encryption-capable TS1120 tape drive coexists with 3592 Model J1A and the non-encryption capable 3592 Model E05 devices in the 3584 automated tape library.
10. The encryption-capable TS1120 tape drive coexists with 3490, 3490E, 3590, and 3592 Model J1A, and the non-encryption capable 3592 Model E05 devices in a manual tape library.
11. The encryption-capable TS1120 tape drive cannot use the MEDIA3 or MEDIA4 cartridges used in 3590 tape drives.
12. The encryption-capable TS1120 tape drive also supports special modes that cause it to behave as a 3592 Model J1A (and therefore foregoing its encryption capabilities). When an encryption-capable TS1120 tape drive is attached to a J70 or C06 control unit that also has 3592 Model J1A devices, the encryption-capable TS1120 tape drive will appear to the host as a

non-encryption-capable 3592 Model J1A, thus ensuring that all devices attached to the same control unit are homogeneous and have the same behaviors.

13. For the system-managed tape support (automated or manual), though a mix of TS1120 (3592 Model E05) tape drives can coexist in the same library, under the same control unit, the TS1120 tape drives must be homogeneous and support the same capabilities. 3592 Model E05 devices that are enabled for encryption cannot coexist in the same control unit with 3592 Model E05 devices that are not encryption capable.

**Related reading:**

- See *IBM System Storage TS1120 Tape Drive and Controller Introduction and Planning Guide*, GA32-0555, for additional information.

---

## Performance scaling and segmentation for TS1120

The encryption-capable TS1120 tape drive supports performance scaling and performance segmentation of media tape cartridges. These functions allow you to optimize performance for MEDIA5 and MEDIA9 cartridges; a cartridge can be defined for performance scaling or performance segmentation, but not both.

Performance scaling, also known as capacity scaling, is a function that allows you to contain data in a specific fraction of the tape, yielding faster locate and read times. Performance scaling for the encryption-capable TS1120 tape drive limits the data written to the first 20% (the optimally scaled performance capacity) of the cartridge. To select performance scaling for a cartridge, do these steps:

1. Define a data class that requests performance scaling.
2. Modify or create ACS routines to associate the tape output functions using performance scaling with a data class that requests performance scaling.

The encryption-capable TS1120 tape drive also divides the tape into longitudinal segments. Using this capability, it is possible to segment the tape into two segments, one as a fast access segment to be filled first, and the other as additional capacity to be filled after. Performance segmentation also avoids the drop in data rate sometimes seen on non-segmented target tapes as they are reaching full capacity. If you decide to use the performance segmentation attribute, do these steps:

1. Define a data class that requests performance segmentation.
2. Modify or create ACS routines to associate the tape output functions using performance segmentation with a data class that requests performance segmentation.

Using EFMT1, the MEDIA5 cartridge can be segmented into a 60 GB fast access segment and a 200 GB slower access segment.

Using EFMT2 or EEFMT2, the MEDIA5 cartridge can be segmented into a 100 GB fast access segment and a 333 GB slower access segment. The MEDIA9 cartridge can be segmented into a 140 GB fast access segment and a 466 GB slower access segment.

## z/OS software support for the encryption-capable TS1120 tape drive

Use z/OS software with the encryption-capable TS1120 tape drive to protect your data with the IBM System Storage family of tape media and the EEFMT2 recording technology. Table 27 describes the software support changes for the new encryption-capable TS1120 tape drive.

*Table 27. Components that provide software support for the encryption-capable TS1120 tape drive*

Component	Function
DFSMSdfp AMS	AMS commands, CREATE VOLUMEENTRY, ALTER VOLUMEENTRY, DCOLLECT, and LISTCAT are changed to support the new EEFMT2 recording technology for encryption. One new subparameter, EEFMT2, for the parameter RECORDING, has been added for CREATE VOLUMEENTRY and ALTER VOLUMEENTRY. AMS allows the use of the new EEFMT2 recording technology, as well as the printing and displaying of information about the recording technology.
DFSMSdfp Device Services	Device Services manages the IBM System Storage Tape System devices.
DFSMSdfp ISMF	The ISMF Data Class Application and Mountable Tape Volume Application panels have been enhanced to allow the specification of a new value (EE2 for EEFMT2) in the Recording Technology Format field. A new panel (DGTDCDC8) will be displayed to allow the specification of key labels and encoding mechanisms.
DFSMSdfp NaviQuest	NaviQuest sample jobs and CLISTs have been updated to support tape encryption in the data class.
DFSMSdfp OAM	OAM tape library support allows the use of the new EEFMT2 recording technology and IBM System Storage family of tape media in the IBM 3494 and 3584 Automated Tape library and in the manual tape library. OAM object tape support allows the use of encryption-capable TS1120 tape drives and media for object-related activity.
DFSMSdfp OCE/IFGOJES3	OCE/IFGOJES3 allows the use of the new EEFMT2 recording technology.
DFSMSdfp SMS	SMS allows the use of the new EEFMT2 recording technology. You can specify a data class to require data encryption (EEFMT2) with media types MEDIA5 through MEDIA10. You can also use a data class to specify two new key labels and two new corresponding key encoding mechanisms. Specification of the key labels is optional and is only valid with DISP=NEW and file sequence number 1. Otherwise, it is ignored.

Table 27. Components that provide software support for the encryption-capable TS1120 tape drive (continued)

Component	Function
DFSMSdss	<p>DFSMSdss ensures that encrypted data dumped to an encryption-capable TS1120 tape drive will not be doubly encrypted, unless the user makes specific arrangements for double-encryption.</p> <p>DFSMSdss Stand Alone Restore will not read a dump data set that resides on an encrypted tape.</p>
DFSMShsm	<p>DFSMShsm allows the use of encryption-capable TS1120 tape drives and media for all DFSMShsm tape related functions:</p> <p><b>LIST command</b> The LIST TTOC SELECT parameters have been extended to take new values EEFMT2 (or EE2), ENCRYPTION (or ENCRYPTED), and NOENCRYPTION (or NOTENCRYPTED).</p> <p><b>Tape hardware encryption for DFSMShsm Dump</b> The DFSMShsm Dump function can now use tape hardware encryption to encrypt dump output. If DUMPCCLASS specifies host based encryption (and possibly host based compaction before encryption, known as HWCOMP), but the associated data class specifies tape hardware encryption, DFSMSdss will ignore the request for host based encryption and honor instead the request for tape hardware encryption. The volume's associated DVL record will show whether tape hardware encryption or host based encryption was done.</p> <p>The LIST DUMPVOL(vol) output includes a new value of THW for the ENC heading indicating the data is Tape Hardware Encrypted.</p> <p>For z/OS V1R8 and above, LIST COPYPOOL shows a value of THW for a Tape Hardware Encrypted tape.</p>
DFSMSrmm	<p>DFSMSrmm records the Key Labels and their encoding mechanism in the Volume record.</p>
DFSORT	<p>DFSORT works without change with the IBM System Storage Tape System devices.</p>

Table 27. Components that provide software support for the encryption-capable TS1120 tape drive (continued)

Component	Function
EREP	EREP provides unique device type information for encryption-capable TS1120 tape drives when formatting LOGREC records.
z/OS Multiple Virtual Storage (MVS) Allocation	MVS Allocation allows specification of the key labels. It also allows the use of the new EEFMT2 recording technology when using the Dynamic Allocation Text Unit DALINCHG.
z/OS Multiple Virtual Storage (MVS) IOS	<p>MVS IOS has been updated to support Key Management:</p> <p><b>In-band Key Management</b>            If in-band key management is being used, the existing IOS PARMLIB member IECIOSxx will be updated specifying the TCP/IP related information needed to direct the ESCON/FICON proxy to the appropriate Encryption Key Manager. In this case, encryption key management (in-band) is defined for the system through the IOS PARMLIB member.</p> <p><b>IOS Proxy Sockets Initialization</b>            You can optionally specify the DNS name or IP address of an Encryption Key Manager (EKM) that will provide the key management functions for the system. The EKM can be designated with a new keyword in the IECIOSxx SYS1.PARMLIB member or as a keyword on the SETIOS operator command.</p> <p><b>IECIOSXX Parmlib and SETIOS Commands</b>            You can use the EKM subcommand in parmlib or in the SETIOS console command to specify the host name of the Encryption Key Manager (primary and secondary).</p>
z/OS Multiple Virtual Storage (MVS) Scheduler/SJF	MVS Scheduler/SJF validates the JCL DD keywords KEYLABEL1, KEYLABEL2, KEYENC1, and KEYENC2, if used.

## Using encryption-capable TS1120 tape drives in an IBM tape library environment

z/OS DFSMS provides device allocation and media management in the 3494 and 3584 automated or manual tape library environments for encryption-capable TS1120 tape drives. This full support is required when encryption-capable TS1120 tape drives are installed in an IBM tape library environment. Encryption-capable

TS1120 tape drives can coexist in the same library with TS1120 drives that are not encryption-capable, as well as 3950 Model B1x, 3590 Model E1x, 3590 Model H1x and 3592 Model J1A drives. However, depending on the library type and model, certain device types may only be supported in certain libraries. For example, the IBM 3584 automated tape library supports only the 3592 family of tape drives.

Inside an IBM tape library, only 3590 Model B1x emulation is supported. The system-managed tape library support recognizes the device as its real device type instead of its emulated device type; this enables "real" and emulated 3590 Model B1x tape drives to coexist and be properly managed in the same IBM tape library.

To request WORM media in a system-managed tape library environment and to ensure that WORM media is only used when explicitly requested, if a WORM scratch volume is to be used, media types MEDIA6, MEDIA8, or MEDIA10 must be explicitly specified through data class. For the 3592 Model E05, if a media type is not specified through data class, MEDIA9 is the primary scratch media type, MEDIA5 is the alternate scratch media type if there are no MEDIA9 scratch volumes available, and MEDIA7 is the second alternate scratch media if there are no MEDIA9 or MEDIA5 scratch volumes available.

Before using the new encryption-capable TS1120 tape drive, ensure that all existing 3592 Model J1A and E05 drives in the library are upgraded to recognize and enable cartridges formatted for EFMT2 or EEFMT2 to be relabelled/reused on the 3592 Model J1A and E05 drives. Otherwise, job failures may occur with a drive with the incorrect microcode load being allocated.

## Using encryption-capable TS1120 tape drives in a stand-alone environment

Encryption-capable TS1120 tape drives emulate already-supported tape devices. To use these drives in a nonlibrary environment, you must manage mixed media and resolve drive allocation ambiguities between encryption-capable TS1120 tape drives, and other 3590 Model B1x emulated devices. This is because the emulated device type is recorded in the data set records of user catalogs. You must manage media and device allocation according to your installation's storage management policies. You must segregate real and emulated device types.

Before using the new encryption-capable TS1120 tape drive, ensure that all existing 3592 Model J1A and E05 drives are upgraded to recognize and enable cartridges formatted for EFMT2 or EEFMT2 to be relabelled/reused on the 3592 Model J1A and E05 drives. Otherwise, job failures may occur with a drive with the incorrect microcode load being allocated.

**Recommendation:** Use a manual tape library, DFSMSrmm, third-party tape management software, or write your own applications when using encryption-capable TS1120 tape drives in a stand-alone environment.

---

## Resolving recording technology conflicts for TS1120

3592 Model J1A devices, 3592 Model E05 devices that are not encryption-capable, and encryption-capable TS1120 tape drives can all write to MEDIA5-MEDIA8 media types. However, conflicts occur when an EEFMT2 formatted cartridge is mounted on a 3592 tape drive that is not encryption-capable and is being relabelled/reused.

The OPEN and EOVS routines can resolve these recording technology conflicts if you meet these conditions:

- Set OPEN for output to the first file
- Specify VOLNSNS=YES in the DEVSUPxx member of PARMLIB
- Position the tape cartridge at the load point.

If these conditions are met and if the cartridge has an internal *volser* recorded in its volume control region, OPEN and EOVS routines rewrite the VOL1 label with the volume identifier in the sense data.

**Note:** To enable this support, make sure that the 3592 Model J1A devices and any 3592 Model E05 devices that are not encryption-capable are at the appropriate microcode level, so that an up-level volume can have its volume identifier returned in the sense data.

For additional information about resolving recording technology conflicts, see *z/OS DFSMS Using Magnetic Tapes* and *z/OS DFSMS Installation Exits*.

---

## Implementation considerations for using encryption-capable TS1120 tape drives

Consider these implementation tasks for using DFSMS software support for encryption-capable TS1120 tape drives.

- For non-specific mount requests in a stand-alone (non-SMS) tape environment, there are no automatic system controls for WORM cartridges. This can result in inadvertent and irreversible writes to WORM media. Using the tape management system pooling support to set up pools to select WORM versus R/W tape media and selecting economy length, standard length, or extended length cartridges help to guarantee that the correct media type is mounted. In addition, SMS data class policies can be used to control WORM mounts for stand-alone, non-specific mount requests. There are two ways to enforce the data class media policy:
  - Specify the DEVSUPxx keyword, ENFORCE\_DC\_MEDIA=ALLMEDIATY. ALLMEDIATY enforces all data class media policies for all stand-alone scratch mounts.
  - Specify the DEVSUPxx keyword, ENFORCE\_DC\_MEDIA=MEDIA5PLUS. MEDIA5PLUS ensures data class media policies for MEDIA5, MEDIA6, MEDIA7, MEDIA8, MEDIA9, and MEDIA10 are enforced for stand-alone scratch mounts.
- In the manual tape library (SMS) environment, WORM scratch mounts can be managed through the tape management system pooling support instead of data class. The DEVSUPxx keyword, MTL\_NO\_DC\_WORM\_OK, allows a WORM scratch volume to be used, even if it was not explicitly requested through data class.
- For the IBM TotalStorage Enterprise Tape Cartridge (MEDIA5 or MEDIA9), use the performance scaling attribute specified through the ISMF data class application if you want to select optimal performance scaling for certain types of jobs and applications. The default setting is to use the tape to its full capacity. This can be specified for tape allocations that are inside or outside an IBM tape library environment.
- For the IBM TotalStorage Enterprise Tape Cartridge (MEDIA5 or MEDIA9), use the performance segmentation attribute specified through the ISMF data class application if you want to divide the cartridge into a fast access segment and a



slower access segment. The fast access segment will be filled first, after which the slower segment will be filled. The performance segmentation option is mutually exclusive with the performance scaling option.

- If you have mixed 3590-1 devices in a non-SMS environment, you need to define a unique esoteric name for each recording technology. Identify the esoteric names to DFSMSHsm using the SETSYS USERUNITTABLE(*esoteric1:esoteric1, esoteric2:esoteric2...*) command to ensure that the correct device type is requested when the tape is mounted for input or output. If your installation uses SMS-managed tape devices or has a single 3590-1 recording technology, you do not need to define an esoteric for those devices; you might need to specify that DFSMSHsm allows mixed devices in the 3590-1 generic name (see APAR OW57282).
- In the stand-alone (non-SMS) environment, perform these implementation steps:
  1. Define data classes or alter existing data classes to:
    - As appropriate, specify either EE2 (EEFMT2 recording format) for encryption or use the media interchange recording technology specification (E1) to request that the lower recording format EFMT1 be used. By default, when writing from load point, EFMT2 is used by the encryption-capable TS1120.
    - Optionally specify key labels (valid only with DISP=NEW and file sequence number 1) and corresponding key encoding mechanisms.
    - Use the performance scaling attribute or performance segmentation attribute with the IBM TotalStorage Enterprise Tape Cartridge (MEDIA5 or MEDIA9).
    - To take advantage of the data class media enforcement support enabled through DEVSUPxx (ENFORCE\_DC\_MEDIA=ALLMEDIATY or ENFORCE\_DC\_MEDIA=MEDIA5PLUS).
  2. Update the ACS routine to assign the appropriate data class construct.
  3. Validate and activate the new or modified SMS configuration.
- In an IBM tape library environment, perform these implementation steps:
  1. Define data classes or alter existing data classes to:
    - As appropriate, specify either EE2 (EEFMT2 recording format) for encryption or use the media interchange recording technology specification (E1) to request that the lower recording format EFMT1 be used. By default, when writing from load point, EFMT2 is used by the encryption-capable TS1120.
    - Optionally specify key labels (valid only with DISP=NEW and file sequence number 1) and corresponding key encoding mechanisms.
    - Use the performance scaling attribute or performance segmentation attribute with the IBM TotalStorage Enterprise Tape Cartridge (MEDIA5 or MEDIA9).
    - To take advantage of the data class media enforcement support enabled through DEVSUPxx (ENFORCE\_DC\_MEDIA=ALLMEDIATY or ENFORCE\_DC\_MEDIA=MEDIA5PLUS).
  2. Define or alter existing tape storage group constructs.
  3. Update ACS routines to direct allocation to appropriate 3592 devices and media.
  4. Validate and activate the new or modified SMS configuration.
  5. Update parmlib member DEVSUPxx (as appropriate) with the MEDIAx parameters (MEDIA5, MEDIA6, MEDIA7, MEDIA8, MEDIA9, MEDIA10) specifying the library partitioning category codes.

**Related reading:**

See Chapter 28, "Migration to the software support for encryption-capable TS1120 tape drives," on page 187 for migration information and implementation information.

---

## Chapter 28. Migration to the software support for encryption-capable TS1120 tape drives

DFSMS software support for the encryption-capable TS1120 tape drive addresses media management and data allocation in an IBM 3494 Automated Tape Library, in an IBM 3584 Automated Tape Library, and in the manual tape library (MTL). You can manage media and allocate data to appropriate non-library (stand-alone) drives through segregation of the real and emulating drives, third-party tape management software, or user-written applications. You can use the encryption-capable TS1120 tape drive on systems that are running z/OS V1R4 and above. However, to use media types MEDIA9 and MEDIA10, z/OS V1R5 and above must be used.

This topic outlines the tasks and associated procedures that must be performed to migrate to software support for the encryption-capable TS1120 tape drive tape drive in these environments:

- Stand-alone environment
- IBM tape library environment
- HSMplex
- OAMplex
- OCE (Open / Close / End-of-Volume)
- RMMplex

---

### Understanding coexistence considerations for encryption-capable TS1120

Coexistence support for the encryption-capable TS1120 tape drive is provided at z/OS V1R4 and above by installing the needed full-support PTFs without the Device Services enabling PTF. However, with the encryption support for z/OS V1R4, V1R5, and V1R8 being delivered after the GA of z/OS V1R6 and V1R7, in some cases, separate coexistence APARs are also available for V1R4, V1R5, and V1R8. In addition to this, existing device services support prevents the encryption-capable TS1120 tape drives from coming online on a system that does not have all of the full-support PTFs installed. Installation of the Devices Services enabling PTF brings in all of the needed full-support PTFs. Device services will provide coexistence support to allow the encryption-capable TS1120 tape drive to come online, but until the full support is installed, it will appear to the host as a 3592-2 without encryption capability. You must install the needed coexistence support on systems that will not have all of the encryption-capable TS1120 tape drive support installed. See Table 28 on page 188 for a discussion of the coexistence PTFs that may be needed. For past discussion of the 3592 Model J1A and its coexistence considerations, refer to “Understanding coexistence considerations for 3592 Model J1A” on page 347. For past discussion of the 3592 Model E05 and its coexistence considerations, refer to “Understanding coexistence considerations for 3592 Model E05” on page 271.

Review the coexistence migration tasks described in these topics:

Table 28. Coexistence migration tasks for encryption-capable TS1120 tape drives

Environment	Coexistence Considerations
Stand-Alone	<p>As described in Chapter 27, "Introduction for encryption-capable TS1120 tape drive," on page 169, z/OS DFSMS and related licensed programs provide full support for the encryption-capable TS1120 tape drive and MEDIA5, MEDIA6, MEDIA7, and MEDIA8 with z/OS V1R4 and above, with support for media types MEDIA9 and MEDIA10 being provided with z/OS V1R5 and above. The encryption-capable TS1120 tape drive support enables the tape drives to operate in the stand-alone environment in 3590 Model B1x emulation and to coexist with other emulated tape drives. However, prior to using the new encryption-capable TS1120 tape drive, ensure that all existing 3592 Model J1A and all existing (base support) 3592 Model E05 tape drives have their microcode upgraded to recognize and enable the EEFMT2 formatted cartridges to be relabelled/reused on the 3592 Model J1A and the base 3592 Model E05. Also, ensure that VOLNSNS=YES is in the DEVSUP:xx member of PARMLIB. Otherwise, job failures may occur with a drive with the incorrect microcode load being allocated.</p> <p>In the stand-alone (non-system managed environment), IBM recommends that all the 3592 Model E05 devices under the same control unit be homogeneous for easier separation and management, even though the control unit allows a mix of 3592 Model E05 devices (encryption capable and non-encryption capable).</p>

Table 28. Coexistence migration tasks for encryption-capable TS1120 tape drives (continued)

Environment	Coexistence Considerations
IBM Tape Library	<p>As described in Chapter 27, “Introduction for encryption-capable TS1120 tape drive,” on page 169, z/OS DFSMS and related licensed programs provide full support for the encryption-capable TS1120 tape drive and MEDIA5, MEDIA6, MEDIA7, and MEDIA8, with z/OS V1R4 and above, with support for media types MEDIA9 and MEDIA10 being provided with z/OS V1R5 and above. The system-managed tape library support allows the tape drives to operate in an ATL or MTL environment as 3590 Model B1x devices, providing device allocation and tape media management support. As appropriate for the library type and model, this support allows the encryption-capable TS1120 tape drive to coexist with other emulated 3590-1 tape drives in the same tape library. However, prior to using the new encryption-capable TS1120 tape drive, ensure that all existing 3592 Model J1A and all existing (base support) 3592 Model E05 tape drives have their microcode upgraded to recognize and enable the EEFMT2 formatted cartridges to be relabelled/reused on the 3592 Model J1A and the base 3592 Model E05. Also, ensure that VOLNSNS=YES is in the DEVSUPxx member of PARMLIB. Otherwise, job failures may occur with a drive with the incorrect microcode load being allocated.</p> <p>In addition to this, in the system-managed tape library environment, all 3592 Model E05 drives under the same control unit must have the same recording format capabilities and report under the same ERDS physical identifier (EPI). So if one of the 3592 Model E05 devices has encryption enabled then all of the 3592 Model E05 devices under that same control unit must also have encryption enabled. This ensures that all of the devices under the same control unit are homogeneous and that each device under the same control unit is capable of handling the request.</p> <p>A tape configuration database (TCDB) with EEFMT2 volume records can coexist with lower-level systems. Coexistence support is provided at z/OS V1R4 and above to enable, during job processing, a scratch volume that was previously written with an up-level recording format to be used by a lower-level system that does not recognize the recording format. Because there is only one scratch pool per media type and that scratch pool can be used across systems at different levels of support, this support ignores the recording format that the volume was previously written in and enables the scratch volume to be used on the lower-level system (refer to coexistence APAR OA17573).</p>
DFSMSdfp Device Services/AOM	<p>Coexistence is provided in the Device Service Exit for z/OS V1R4 and above. This allows an encryption-capable 3592 Model E05 drive to come online as a non-encryption capable 3592 Model E05, with the EPI value stored as X'12' in the UCB class extension (UCBCXEPI field in IECUCBCX mapping macro). This allows an encryption-capable drive to be used as a non-encryption capable drive on systems that do not have the full function support installed (refer to coexistence APARs OA16116 and OA16117).</p> <p>When the device services full function support APAR is installed, the Device Service Exit will check if the enabling APAR is also installed. If it is, the Device Service Exit will record the EPI value in the UCB class extension as X'13'.</p> <p>The coexistence support will recognize the new EPI value and display the real device type as 3592-2 for DS QTAPE,MED command. The reason is the new encryption-capable 3592 Model E05 drive looks and acts exactly the same as a non-encryption capable drive in coexistence systems that do not have the full function support installed.</p>

Table 28. Coexistence migration tasks for encryption-capable TS1120 tape drives (continued)

Environment	Coexistence Considerations
HSMplex	<p>In an HSMplex, all systems in the HSMplex should have full support for the 3592-2E tape subsystem before any instance of DFSMSHsm uses tape hardware encryption. If any system does not fully support tape hardware encryption in an HSMplex with tape hardware encrypted tapes, a request for tape input can fail because a 3592-2E device is not available on that system.</p>
OAMplex	<p>For OAM's object support customers, in addition to the planning steps required for migration to the software support for the encryption-capable TS1120 tape drive tape drives in the stand-alone and IBM tape library environments, there are coexistence considerations your installation must take into account before you install the software in an OAMplex:</p> <ul style="list-style-type: none"> <li>• For the encryption-capable TS1120 tape drive support, OAM object tape coexistence support is provided at z/OS V1R4 and above, through installation of the full support PTF without the device services enabling PTF.</li> <li>• OAM coexistence support prevents lower-level systems from selecting volumes with ERDS Physical Identifier (EPI) values for object write requests that are not supported on that system.</li> <li>• OAM object support has coexistence considerations when running in an OAMplex environment with at least one system with the full support installed and enabled and at least one system without the full support for the new devices installed and enabled. In this mixed support environment, it is possible for a retrieve request to be received for an object that resides on a tape cartridge volume written in the EEFMT2 format by a system that does not have the encryption-capable TS1120 tape drive full support installed. Coexistence support is provided that allows OAM to attempt to locate an instance of OAM in the OAMplex where the full support is installed and enabled. If an instance of OAM is found where the request can be processed, the OAM on the system where the request originated will ship the retrieve request, if the object is not greater than 50 MB, to the target system using XCF messaging services.</li> <li>• Once encryption-capable TS1120 tape drive devices are used in an OAMplex environment and objects are written to tape volumes with the new EPI value recorded, it is expected that any OAM on a system where the full support is installed and enabled is eligible for processing requests using that volume. Therefore, encryption-capable TS1120 tape drive devices must be available to all instances of OAM where the full support is installed.</li> </ul>
OCE (Open / Close / End-of-Volume)	<p>The FILEE parameter list is now longer to accommodate the possible KEK labels (key labels) and their encoding mechanism. The version of the FILEE parameter list (TEPEVER) has been updated (to a 2) to reflect the longer FILEE parameter list. Before referencing the key-label related fields in the FILEE parameter list, ensure that either the version is set to 2 or the TEPMCRYP bit is "ON". When the TEPMCRYP bit is "ON", the key-label related fields contain pertinent data, otherwise these fields will contain binary zeroes.</p> <p>Coexistence support is added at z/OS V1R4 and above to prevent an encrypted tape from being used on a lower-level system. If an encrypted volume is detected during OPEN processing on a system that does not have all of the encryption support installed, abend code 613-84: 'no software support for the media type or the recording technology' is issued (refer to coexistence APAR OA17479).</p>

Table 28. Coexistence migration tasks for encryption-capable TS1120 tape drives (continued)

Environment	Coexistence Considerations
RMMplex	For the encryption-capable TS1120 tape drive support, RMM coexistence support is provided at z/OS V1R4 and above, either through installation of the full support RMM PTF without the device services enabling PTF, or by installation of the toleration APAR OA16524. This allows the coexisting system to tolerate tapes written by the encryption-capable TS1120 tape drive in EEFMT2 format and their associated key labels. If client/server is used, APAR OA16523 (preconditioning) is also required and must be installed on all client/server systems before OA16524 toleration is installed on any client/server systems. If you plan to fallback from full function system with encryption function to any other level without encryption, toleration is required on that fallback system also.

---

## Preparing to install the software

Refer to *IBM System Storage TS1120 Tape Drive and Controller Introduction and Planning Guide*, GA32-0555, for hardware requirements. Also refer to the *Encryption Key Manager Introduction, Planning, and User's Guide*, GA76-0418, for Encryption Key Manager requirements.

Coexistence support for the encryption-capable TS1120 tape drive is provided with z/OS V1R4 and above by installing the appropriate full support PTFs without the device services enabling PTF. However, with the encryption support for z/OS V1R4, V1R5, and V1R8 being delivered after the GA of z/OS V1R6 and V1R7, in some cases, separate coexistence APARs are also available for V1R4, V1R5, and V1R8.

---

## Installing the appropriate PTFs

Refer to the 3592 PSP bucket for the APAR and PTF numbers applicable for each release. An enabling PTF exists to provide full device support for the encryption-capable TS1120 tape drive. Installation of the appropriate enabling PTF pulls in all of the needed support PTFs and indicates to the system that all of the needed software support is installed. Support for z/OS V1R6 and z/OS V1R7 will be provided first with support for z/OS V1R8 and z/OS V1R4 and V1R5 following after the initial GA. For z/OS V1R6 and V1R7, refer to enabling APAR OA15685. For z/OS V1R8, refer to enabling APAR OA17562 and for z/OS V1R4 and V1R5, refer to enabling APAR OA18111. With this split GA, in an OAMplex or an HSMplex, before using the encryption-capable TS1120 tape drive, ensure that the appropriate support is available and installed at all of the release levels used in the plex.

In addition, as appropriate for your environment and release level, determine what coexistence PTFs are needed for your environment.

---

## Planning for DFSMS software support for the encryption-capable TS1120 tape drive

The planning steps you must consider to successfully install the encryption-capable TS1120 tape drive software, vary depending upon the tape environment you have installed. Also remember that the encryption-capable TS1120 tape drive is supported on z/OS V1R4 with media types MEDIA5 through MEDIA8, while media types MEDIA9 and MEDIA10 are supported only on z/OS V1R5 and above.

Table 29 discusses planning considerations for stand-alone environments (including tape devices installed in vendors' automated tape libraries) and for IBM tape library environments.

*Table 29. Encryption-capable TS1120 tape drive planning considerations*

Area	Planning Considerations
System customization: stand-alone environment	<ol style="list-style-type: none"> <li>1. Determine which data needs to be encrypted and set up the appropriate data class policy specifying EEFMT2. Also specify, as appropriate, the non-encryption recording formats, EFMT1 or EFMT2. If a encryption-capable TS1120 tape drive is allocated, the default recording format is EFMT2. Also, modify or create ACS routines to associate the tape output functions with a data class that has the appropriate recording format specified.</li> <li>2. Determine which key labels are to be used and how they will be specified, data class, the DD statement or Encryption Key Manager established defaults.</li> <li>3. Determine whether you will need help from your tape management system vendor and contact them, if needed.</li> <li>4. Plan for the installation of the Encryption Key Manager (EKM) and decide which of the supported key stores to use.</li> <li>5. Plan for the key labels that will be used and the encoding mechanism (label or hash) for each and where the key labels will be specified.</li> <li>6. For in-band key management, update the IOS PARMLIB member (IECIOSxx) using the new EKM command. Also create a z/OS UNIX segment for the IOS address space.</li> <li>7. Upgrade 3592 Model J1A and 3592 Model E05 drive microcode to enable the drives to recognize and enable the EEFMT2 formatted cartridges to be relabelled/reused. Also, ensure that VOLNSNS=YES is in the DEVSUPxx member of PARMLIB.</li> <li>8. With availability of the new media (MEDIA9 and MEDIA10), determine what microcode updates are needed. Prior to using the new media types (MEDIA9 and MEDIA10), ensure that all 3592 Model E05 drives have had their microcode upgraded in support of the new media types. Otherwise, job failures may occur with a 3592 drive with the wrong microcode level being allocated.</li> <li>9. Determine which systems should have coexistence support and which systems should have full support.</li> <li>10. Determine when to IPL the host machine after installing the coexistence PTFs, if needed.</li> <li>11. Determine when to IPL the host machine after installing all necessary PTFs.</li> </ol>



Table 29. Encryption-capable TS1120 tape drive planning considerations (continued)

Area	Planning Considerations
System customization: IBM library tape environment	<ol style="list-style-type: none"> <li>1. Determine which data needs to be encrypted and set up the appropriate data class policy specifying EEFMT2. Also, specify as appropriate, the non-encryption recording formats, EFMT1 or EFMT2. If a encryption-capable TS1120 tape drive is allocated, the default recording format is EFMT2. Also, modify or create ACS routines to associate the tape output functions with a data class that has the appropriate recording format specified.</li> <li>2. Determine which key labels are to be used and how they will be specified, data class, the DD statement or Encryption Key Manager established defaults.</li> <li>3. Determine whether you will need help from your tape management system vendor and contact them, if needed.</li> <li>4. Plan for the installation of the Encryption Key Manager (EKM) and decide which of the supported key stores to use.</li> <li>5. Plan for the key labels that will be used and the encoding mechanism (label or hash) for each and where the key labels will be specified.</li> <li>6. For in-band key management, update the IOS PARMLIB member (IECIOSxx) using the new EKM command. Also create a z/OS UNIX segment for the IOS address space.</li> <li>7. Upgrade 3592 Model J1A and 3592 Model E05 microcode to enable the library drives to recognize and enable the EEFMT2 formatted cartridges to be relabelled/reused. Also, ensure that VOLNSNS=YES is in the DEVSUPxx member of PARMLIB.</li> <li>8. With availability of the new media (MEDIA9 and MEDIA10), determine what microcode updates are needed. Prior to using the new media types (MEDIA9 and MEDIA10), ensure that all 3592 Model E05 drives have had their microcode upgraded in support of the new media types. Otherwise, job failures may occur with a 3592 drive with the wrong microcode level being allocated.</li> <li>9. Identify the installation exit changes that are needed.</li> <li>10. Determine which systems should have coexistence support and which systems should have full support.</li> <li>11. Determine when to IPL the host machine after installing the coexistence PTFs, if needed.</li> <li>12. Determine when to IPL the host machine after installing all necessary PTFs.</li> </ol>

Table 29. Encryption-capable TS1120 tape drive planning considerations (continued)

Area	Planning Considerations
System customization: OAM object tape environment	<p>The planning steps that you must consider in tape environments that use OAM objects vary depending upon the type of environment that is installed.</p> <ol style="list-style-type: none"> <li>1. If you install the new encryption-capable TS1120 tape drive devices in a stand-alone environment:               <ol style="list-style-type: none"> <li>a. Follow the system customization planning steps listed for a stand-alone environment.</li> <li>b. Determine the esoteric or generic device names that need to be added to STORAGEGROUP statements in the CBROAMxx member of PARMLIB for the object storage groups that are to use the new devices.</li> <li>c. Determine whether to use the global keyword DSNWITHSGNAME on the SETOAM statement in the CBROAMxx member of PARMLIB to append the object storage group name to the OAM object tape data set names. See “Object tape data set low-level qualifier enhancement” on page 413 for additional information.</li> <li>d. Determine the new data classes that need to be defined in STORAGEGROUP statements in the CBROAMxx member of PARMLIB for the object storage groups that are to use the new encryption format EEFMT2.</li> </ol> </li> <li>2. If you install the new encryption-capable TS1120 tape drive devices in an IBM tape library:               <ol style="list-style-type: none"> <li>a. Follow the system customization planning considerations listed for an IBM tape library environment.</li> <li>b. Determine the new data classes that need to be defined in STORAGEGROUP statements in the CBROAMxx member of PARMLIB for the object storage groups that are to use the new devices and the new encryption format EEFMT2.</li> </ol> </li> <li>3. In addition, if you install the new encryption-capable TS1120 tape drive devices in an OAMplex:               <ol style="list-style-type: none"> <li>a. Ensure that the new encryption-capable TS1120 tape drive devices are available to all instances of OAM where the full support software is installed.</li> <li>b. Determine whether systems exist that will require coexistence support. This situation is particularly important in an OAMplex where at least one system has the full-support software installed and enabled, and at least one system will not have all of the support installed or enabled. Coexistence support is needed if not all of the systems in the OAMplex will be at the same full-support level.</li> <li>c. To provide this coexistence support, as appropriate for the support and the release level, install the OAM full-support PTF without the enabling PTF or any separate coexistence support PTF.</li> <li>d. Determine when to IPL the host machine after installing the coexistence PTFs, if needed.</li> </ol> </li> </ol>
System customization: DFSMSHsm	See “Implementation considerations for using encryption-capable TS1120 tape drives” on page 184 and “DFSMSHsm tips” on page 233.

Table 29. Encryption-capable TS1120 tape drive planning considerations (continued)

Area	Planning Considerations
Storage administration: stand-alone tape environment	<ol style="list-style-type: none"> <li>1. Determine how to setup your tape management systems pooling support to segregate rewritable (MEDIA5, MEDIA7, and MEDIA9) and WORM (MEDIA6, MEDIA8, and MEDIA10) media and also to segregate the standard, economy, and extended length cartridges, as appropriate for their job and application usage.</li> <li>2. Review the usage of the DEVSUP:xx PARMLIB option, ENFORCE_DC_MEDIA, (optional) to ensure that the media type mounted is the media type requested through data class. This can be used in conjunction with the tape management systems pooling support as an additional safety check.</li> <li>3. Review the existing SMS data class media policies to ensure compatibility with existing tape scratch pool policies before enabling the DEVSUP:xx PARMLIB option, ENFORCE_DC_MEDIA.</li> <li>4. Review the existing SMS data class recording technology policies to ensure that data set policies set to EFMT1 are being appropriately used. If a encryption-capable TS1120 tape drive is allocated and the specified data class indicates EFMT1, the drive will record in the lower recording technology.</li> <li>5. Determine the data class updates that are needed to request the appropriate recording format for the encryption-capable TS1120 tape drives. If an encryption-capable TS1120 tape drive is allocated, the default recording format is EFMT2 (non-encryption).</li> <li>6. Determine if media should use performance segmentation, with a fast access segment to be filled first, and a slower access segment to be filled after. If you decide to use the performance segmentation attribute (available with MEDIA5 and MEDIA9 tape cartridges only, and mutually exclusive with performance scaling), you can: <ol style="list-style-type: none"> <li>a. Define a data class that requests performance segmentation.</li> <li>b. Modify or create ACS routines to associate the tape output functions using performance segmentation with a data class that requests performance segmentation.</li> </ol> </li> <li>7. Determine if media should be used at full capacity or scaled for optimal performance. If you decide to use the performance scaling attribute (available with MEDIA5 and MEDIA9 tape cartridges only), you can: <ol style="list-style-type: none"> <li>a. Define a data class that requests performance scaling.</li> <li>b. Modify or create ACS routines to associate the tape output functions using performance scaling with a data class that requests performance scaling.</li> </ol> </li> <li>8. Determine how to allocate media to appropriate nonlibrary drives. Consider using the IBM manual tape library. You can also segregate the real drives from the emulating drives, use third-party tape management software, or use customer-written applications.</li> <li>9. Identify any needed changes to the hardware configuration definition (HCD) to define the new devices.</li> </ol>

Table 29. Encryption-capable TS1120 tape drive planning considerations (continued)

Area	Planning Considerations
Storage administration: IBM tape library environment	<ol style="list-style-type: none"> <li>1. Review the usage of the DEVSUPxx PARMLIB option, MTL_NO_DC_WORM_OK, if the WORM cartridges in the manual tape library environment will be mounted through use of the tape management systems pooling support versus a data class WORM media specification.</li> <li>2. Determine the 3592 media usage of rewritable (MEDIA5, MEDIA7, and MEDIA9) and WORM (MEDIA6, MEDIA8, and MEDIA10) media and also the usage of the standard, economy, and extended length cartridges. Then make the appropriate data class definition updates to select the appropriate media type. WORM media can only be used if explicitly requested through data class.</li> <li>3. Review ACS routines for changes needed in selecting tape storage groups and libraries that have the new encryption-capable TS1120 tape drive devices.</li> <li>4. Determine the data class updates that are needed to use the recording technology, media type, and performance scaling or performance segmentation data class attribute (performance scaling or segmentation available with MEDIA5 and MEDIA9 tape cartridges only).</li> <li>5. Identify any needed changes to the HCD to define the new devices.</li> <li>6. To define the partitioning category code for MEDIA5, MEDIA6, MEDIA7, MEDIA8, MEDIA9, and MEDIA10 tape cartridges, specify the appropriate parameter of the DEVSUPxx parmlib member.</li> </ol>
Storage administration: OAM object tape environment	<p>The planning steps that you must consider in tape environments that use OAM objects vary depending upon the type of environment that is installed.</p> <ol style="list-style-type: none"> <li>1. If you install the new encryption-capable TS1120 tape drive devices in a stand-alone environment, follow the storage administration planning steps listed for a stand-alone environment.</li> <li>2. If you install the new encryption-capable TS1120 tape drive devices in an IBM tape library: <ol style="list-style-type: none"> <li>a. Follow the storage administration planning steps listed for an IBM tape library environment.</li> <li>b. Review ACS routines for STORE or CTRANS environments and make any changes needed to ensure proper class assignment.</li> </ol> </li> <li>3. If you install the new encryption-capable TS1120 tape drive devices in an OAMplex, you must make the devices available to all instances of OAM where the full support is installed.</li> </ol>

Implementing this change could affect these areas of your processing environment:

Area	Considerations
Storage Administration	<p>For the new 3592 media support (MEDIA9 and MEDIA10), these NaviQuest sample jobs have been changed for this function:</p> <ul style="list-style-type: none"> <li>• ACBJBAD1 is the sample job used to define, alter, or display a data class.</li> <li>• ACJBAIL is the sample job to generate data class list and a data class report.</li> <li>• ACJBAIN is the sample job to generate data class report from a saved list.</li> </ul> <p>ISMF panels have been changed. See <i>z/OS DFSMSdfp Storage Administration</i> for information about the ISMF panel changes. See Chapter 31, "ISMF modifications for encryption-capable TS1120 tape drive," on page 219 for information about ISMF support for the encryption-capable TS1120 tape drive.</p>

Area	Considerations
Operations	<p>These commands have been updated with this support:</p> <ul style="list-style-type: none"> <li>• DEVSERV QTAPE</li> <li>• DISPLAY IOS,EKM</li> <li>• DISPLAY SMS,VOLUME</li> <li>• IDCAMS ALTER VOLUMEENTRY</li> <li>• IDCAMS CREATE VOLUMEENTRY</li> <li>• IDCAMS DCOLLECT</li> <li>• IDCAMS LISTCAT</li> <li>• LIBRARY DISPDRV</li> <li>• SETIOS EKM</li> </ul>
Auditing	None.
Application development	<p>The mapping macros and installation exits listed have been changed for this function.</p> <ul style="list-style-type: none"> <li>• CBRTDSI - Maps the Tape Device Selection Information</li> <li>• CBRTVI - Maps the Tape Volume Information</li> <li>• CBRUXCPL - Installation Exit CBRUXCUA Parameter List</li> <li>• CBRUXEPL - Installation Exit CBRUXENT Parameter List</li> <li>• CBRUXJPL - Installation Exit CBRUXEJC Parameter List</li> <li>• CBRUXNPL - Installation Exit CBRUXVNL Parameter List</li> <li>• DALINCHG - Dynamic Allocation DALINCHG Text Unit</li> <li>• EDGXMLAP - DFSMSrmm XML schema file</li> <li>• IECUCBCX - Maps the Tape UCB Device Class extension</li> <li>• IEFSJKEY - SJF / Dynamic Allocation Keys</li> <li>• IFGTEP - Maps the installation exit main parameter list</li> <li>• IEZDEB - Maps the data extent block (DEB)</li> <li>• IHADFVT - Maps the data facilities vector table</li> </ul>
Diagnostic procedures	<p>The messages listed have been changed for this support.</p> <ul style="list-style-type: none"> <li>• ADR518I</li> <li>• ADR519E</li> <li>• ADR992E</li> <li>• ADRY513I</li> <li>• ARC0030I</li> <li>• CBR0119I</li> <li>• CBR1083I</li> <li>• CBR1180I</li> <li>• CBR1220I</li> <li>• CBR6419I</li> <li>• IEC026I</li> <li>• IEC147I</li> <li>• IEC205I</li> <li>• IEC211I</li> <li>• IGF513I</li> <li>• IOS000I</li> <li>• IOS0631I</li> <li>• IOS085I</li> <li>• IOS090I</li> <li>• IOS099I</li> <li>• IOS0627E</li> <li>• IOS0628E</li> </ul>

Area	Considerations
Automation products	None.
General use	For DFSMSrmm, use the RMM subcommands ADDVOLUME, CHANGEVOLUME, and SEARCHVOLUME to specify the recording technology EEFMT2 and the key labels KEYLABEL1/KEYENCODE1 and KEYLABEL2/KEYENCODE2.

## Implementing the DFSMS software support for the encryption-capable TS1120 tape drive

To implement the encryption-capable TS1120 tape drive software support, perform the system-level and application-level tasks listed in the following tables. **Required** tasks apply to any DFSMS installation enabling the function. **Optional** tasks apply to only specified operating environments or to situations where there is more than one way to set up or enable the function. For more details on the procedures associated with a given task, see the reference listed.

System-level tasks	Condition	Procedure reference
<p><i>Stand-alone tape environment</i></p> <ol style="list-style-type: none"> <li>1. Implement the data class policy specifying EEFMT2. Also, specify as appropriate, the non-encryption recording formats, EFMT1 or EFMT2. Also, modify or create ACS routines to associate the tape output functions with a data class that has the appropriate recording format specified.</li> <li>2. Install the Encryption Key Manager (EKM) and set up the key store it will use.</li> <li>3. Create the data classes or the DD statements (or use Encryption Key Manager defaults) to specify the key labels and their encoding mechanism (label or hash).</li> <li>4. For in-band key management, update the IOS PARMLIB member (IECIOSxx) using the new EKM command. Also create a z/OS UNIX segment for the IOS address space.</li> <li>5. Upgrade 3592 Model J1A and 3592 Model E05 microcode to enable the drives to recognize and enable the EEFMT2 formatted cartridges to be relabelled/reused. Also, ensure that VOLNSNS=YES is in the DEVSUP:xx member of PARMLIB.</li> <li>6. Ensure that the required microcode updates for the new media (MEDIA9 and MEDIA10) have been made. Prior to using the new media types (MEDIA9 and MEDIA10), ensure that all 3592 Model E05 drives have had their microcode upgraded in support of the new media types. Otherwise, job failures may occur with a 3592 drive with the wrong microcode level being allocated.</li> <li>7. Make the required installation exit changes.</li> <li>8. Make any needed changes to the HCD to define the new devices.</li> <li>9. If more than one recording technology is used for the same device type, create a unique esoteric for each of the recording technologies. Use the esoteric unit names in DFSMShsm to direct allocations uniquely to each group of devices.</li> <li>10. If performance scaling or performance segmentation is used (available with MEDIA5 and MEDIA9 tape cartridges only), update or create ACS routines to assign a data class to tape output functions. For example, for DFSMShsm, you can filter on single file tape data set names used by DFSMShsm functions. Define the data class with the performance scaling or performance segmentation attribute.</li> <li>11. Add new device esoteric unit names or generic unit names to STORAGEGROUP statements in the CBROAM:xx member of PARMLIB for the object storage groups that are to use the new devices. The esoteric or generic unit name must consist of encryption-capable TS1120 tape drive drives exclusively because the EEFMT2 recording technology is not compatible with other recording technologies.</li> <li>12. Install coexistence PTFs as appropriate.</li> <li>13. IPL the system.</li> </ol>	Required	<ul style="list-style-type: none"> <li>• <i>z/OS DFSMS OAM Planning, Installation, and Storage Administration Guide for Object Support</i></li> <li>• <i>z/OS HCD User's Guide</i></li> <li>• <i>z/OS DFSMShsm Implementation and Customization Guide</i></li> </ul>

System-level tasks	Condition	Procedure reference
<p><i>IBM tape library environment</i></p> <ol style="list-style-type: none"> <li>1. Implement the data class policy specifying EEFMT2. Also, specify as appropriate, the non-encryption recording formats, EFMT1 or EFMT2. Also, modify or create ACS routines to associate the tape output functions with a data class that has the appropriate recording format specified.</li> <li>2. Install the Encryption Key Manager (EKM) and set up the key store it will use.</li> <li>3. Create the data classes or the DD statements (or use Encryption Key Manager defaults) to specify the key labels and their encoding mechanism (label or hash).</li> <li>4. For in-band key management, update the IOS PARMLIB member (IECIOSxx) using the new EKM command. Also create a z/OS UNIX segment for the IOS address space.</li> <li>5. Upgrade 3592 Model J1A and 3592 Model E05 microcode to enable the library drives to recognize and enable the EEFMT2 formatted cartridges to be relabelled/reused. Also, ensure that VOLNSNS=YES is in the DEVSUP:xx member of PARMLIB.</li> <li>6. Ensure that the required microcode updates for the new media (MEDIA9 and MEDIA10) have been made. Prior to using the new media types (MEDIA9 and MEDIA10), ensure that all 3592 Model E05 drives have had their microcode upgraded in support of the new media types. Otherwise, job failures may occur with a 3592 drive with the wrong microcode level being allocated.</li> <li>7. Make the required installation exit changes.</li> <li>8. Define or alter existing data class constructs as appropriate, to specify the EEFMT2 recording technology, MEDIA5, MEDIA6, MEDIA7, or MEDIA8, MEDIA9, or MEDIA10 media type, and the performance attributes (performance scaling or performance segmentation available with MEDIA5 and MEDIA9 tape cartridges only).</li> <li>9. Define or alter existing storage group constructs to include libraries with the new encryption-capable TS1120 tape drive devices.</li> <li>10. Update ACS routines to direct allocation to the encryption-capable TS1120 tape drive device as requested.</li> <li>11. Validate and activate any new or modified SMS configuration.</li> <li>12. Make any needed changes to the HCD to define the new devices.</li> <li>13. To define the partitioning category code for MEDIA5, MEDIA6, MEDIA7, or MEDIA8, MEDIA9, or MEDIA10 tape cartridges, specify the appropriate parameter of the DEVSUP:xx parmlib member.</li> <li>14. When systems are sharing a library with 3592 Model E05 (encryption-capable) installed, install coexistence PTFs as appropriate.</li> <li>15. IPL the system.</li> </ol>	Required	<ul style="list-style-type: none"> <li>• <i>z/OS DFSMS OAM Planning, Installation, and Storage Administration Guide for Tape Libraries</i></li> <li>• <i>z/OS HCD User's Guide</i></li> <li>• <i>z/OS DFSMSdfp Storage Administration</i></li> </ul>



System-level tasks	Condition	Procedure reference
<p data-bbox="188 216 456 241"><i>OAM object tape environment</i></p> <p data-bbox="188 268 821 342">The migration steps that you must take in tape environments that use OAM objects vary depending upon the type of environment that is installed:</p> <ol data-bbox="188 352 821 1514" style="list-style-type: none"> <li data-bbox="188 352 821 636">1. If you install the new encryption-capable TS1120 tape drive devices in an OAMplex: <ol data-bbox="224 415 821 636" style="list-style-type: none"> <li data-bbox="224 415 821 489">a. Make the new encryption-capable TS1120 tape drive devices available to all instances of OAM where the full support software is installed.</li> <li data-bbox="224 499 821 525">b. Install coexistence PTFs as appropriate.</li> <li data-bbox="224 535 821 636">c. Consider setting DSNWITHSGNAME in the SETOAM statement in the CBROAMxx PARMLIB member. Review your ACS routines if appending the storage group name to OAM data set names (DSNWITHSGNAME).</li> </ol> </li> <li data-bbox="188 646 821 909">2. If you install the new encryption-capable TS1120 tape drive devices in an IBM tape library: <ol data-bbox="224 709 821 909" style="list-style-type: none"> <li data-bbox="224 709 821 762">a. Follow the migration steps listed for an IBM tape library environment.</li> <li data-bbox="224 772 821 846">b. Define the new data classes in STORAGEEGROUP statements in the CBROAMxx member of PARMLIB for the object storage groups that are to use the new devices.</li> <li data-bbox="224 856 821 909">c. Make the needed changes to ACS routines for ALLOC, STORE, or CTRANS environments.</li> </ol> </li> <li data-bbox="188 919 821 1514">3. If you install the new encryption-capable TS1120 tape drive devices in a stand-alone environment: <ol data-bbox="224 982 821 1514" style="list-style-type: none"> <li data-bbox="224 982 821 1035">a. Follow the migration steps listed for a stand-alone environment.</li> <li data-bbox="224 1045 821 1224">b. Add new device esoteric unit names or generic unit names to STORAGEEGROUP statements in the CBROAMxx member of PARMLIB for the object storage groups that are to use the new devices. The esoteric or generic unit name must consist of encryption-capable TS1120 tape drive drives exclusively because the EFMT2 recording technology is not compatible with other recording technologies.</li> <li data-bbox="224 1234 821 1329">c. Consider setting DSNWITHSGNAME in the SETOAM statement in the CBROAMxx PARMLIB member. Review your ACS routines if appending the storage group name to OAM data set names (DSNWITHSGNAME).</li> <li data-bbox="224 1339 821 1392">d. Make the needed changes to ACS routines for ALLOC, STORE and CTRANS environments.</li> <li data-bbox="224 1402 821 1514">e. Define the new data classes in STORAGEEGROUP statements in the CBROAMxx member of PARMLIB for the object storage groups that are to use the new encryption format EEFMT2.</li> </ol> </li> </ol>	Required	<p data-bbox="1065 216 1448 289"><i>z/OS DFSMS OAM Planning, Installation, and Storage Administration Guide for Object Support</i></p>
<p data-bbox="188 1524 456 1549"><i>DFSMSHsm tape environment</i></p> <p data-bbox="188 1577 821 1671">DFSMSHsm allows the specification of tape unit names using either generic or esoteric names. Installations that have a mixture of non-SMS-managed 3590 devices defined under the 3590-1 generic name, need to perform these steps:</p> <ol data-bbox="188 1682 821 1894" style="list-style-type: none"> <li data-bbox="188 1682 821 1707">1. Define a unique esoteric for each recording technology.</li> <li data-bbox="188 1717 821 1894">2. Use the SETSYS USERUNITTABLE command to define these esoteric names to DFSMSHsm. This also applies to mixed devices in the 3490 generic. Installations that use SMS-managed tape devices or have a single 3590-1 recording technology, do not need to define an esoteric for those devices. However, if you have a mixed SMS-managed 3590 environment, please review APAR OW57282.</li> </ol>	Required	<ul data-bbox="1065 1524 1448 1640" style="list-style-type: none"> <li data-bbox="1065 1524 1448 1577">• <i>z/OS DFSMSHsm Implementation and Customization Guide</i></li> <li data-bbox="1065 1587 1448 1640">• <i>z/OS DFSMSHsm Storage Administration</i></li> </ul>

System-level tasks	Condition	Procedure reference
<p data-bbox="157 218 756 243"><i>Setting up DFSMShsm to use WORM output tapes for ABACKUP</i></p> <p data-bbox="157 268 781 447">In a SMS tape environment, and optionally in a non-SMS tape environment, the SMS data class construct can be used to select WORM tapes for ABACKUP processing. The output data set prefix specified in the aggregate group definition can be used by the ACS routines to select a WORM data class. Set up the ACS routine and the output data set name to uniquely identify the ABARS output files that must go to WORM tape.</p> <p data-bbox="157 472 800 653">In a non-SMS tape environment, the default allows tape pooling to determine if ABARS data sets go to WORM or R/W media. Optionally, if the DEVSUP:xx parameter, ENFORCE_DC_MEDIA=ALLMEDIATY or ENFORCE_DC_MEDIA=MEDIA5PLUS, is used, then the data class must request the appropriate media type for it to be successfully mounted.</p>	Required	<ul style="list-style-type: none"> <li data-bbox="1036 218 1401 275">• <i>z/OS DFSMShsm Implementation and Customization Guide</i></li> <li data-bbox="1036 285 1401 338">• <i>z/OS DFSMShsm Storage Administration</i></li> </ul>
Application-level tasks	Condition	Procedure reference
<p data-bbox="157 743 792 896">For programs that use dynamic allocation and cannot take advantage of predefined data class definitions, set the PARM for the DALINCHG text unit key in DALINCHG to specify the media type and recording technology for system-managed tape library allocations.</p>	Optional	<p data-bbox="1036 743 1401 800"><i>z/OS MVS Programming: Authorized Assembler Services Guide</i></p>

---

## Chapter 29. Access method services (AMS) modifications

This topic describes changes to the access method services (AMS) commands to support the new recording technique for encryption. These commands are changed.

- “ALTER VOLUMEENTRY” on page 286
- “CREATE VOLUMEENTRY” on page 292
- “DCOLLECT” on page 295
- “LISTCAT” on page 297

**Attention:** Use these AMS commands only to recover from tape volume catalog errors. Because AMS cannot change the library manager inventory in an automated tape library, use ISMF for normal tape library alter functions.

**Related reading:**

For explanations of all the parameters used with the AMS commands and additional examples, refer to *z/OS DFSMS Access Method Services Commands*.

---

### Enterprise Encrypted Format 2 (EEFMT2)

EEFMT2 recording format is used to specify that the data on the tape is recorded in the encryption format.

---

### EEFMT2 Support for ALTER VOLUMEENTRY

Use the AMS ALTER VOLUMEENTRY command to modify the attributes for an existing tape volume entry.

The ALTER VOLUMEENTRY command allows recording fields in the volume records of a tape library to be altered with a subparameter of EEFMT2 with these rules:

- EEFMT2 subparameter indicates Read/Write on an EEFMT2 track device.
- EEFMT2 subparameter of RECORDING is only allowed with media types MEDIA5, MEDIA6, MEDIA7, MEDIA8, MEDIA9 or MEDIA10. The use of MEDIA1 through MEDIA4 produces an IDC3226I error message being generated twice, once for EEFMT2 and once for the media type. The generation of the two IDC3226I error messages indicates an incompatibility between the EEFMT2 subparameter and the media type displayed.

### EEFMT2 subparameter for ALTER VOLUMEENTRY

```
RECORDING(18TRACK|36TRACK|128TRACK|256TRACK|
384TRACK|EFMT1|EFMT2|EEFMT2|UNKNOWN)
```

This shows the EEFMT2 subparameter associated with the RECORDING parameter for ALTER VOLUMEENTRY

---

## EEFMT2 Support for CREATE VOLUMEENTRY

The CREATE VOLUMEENTRY command allows the recording field in the volume records of a tape library to be created with a subparameter of EEFMT2 with these rules:

- EEFMT2 subparameter indicates READ/WRITE on an EEFMT2 device.
- EEFMT2 is only allowed with media types MEDIA5, MEDIA6, MEDIA7, MEDIA8, MEDIA9, or MEDIA10. Any use of MEDIA1 through MEDIA4 produces an IDC3226I error message being displayed twice, once for EEFMT2 and once for the media in question. The double display indicates an incompatibility between the EEFMT2 subparameter and the media type displayed.
- If MEDIA5, MEDIA6, MEDIA7, or MEDIA8 are specified and RECORDING is not specified, default to EFMT1 for RECORDING value.
- If MEDIA9 or MEDIA10 are specified and RECORDING is not specified, default to EFMT2 for RECORDING value.

### EEFMT2 subparameter for CREATE VOLUMEENTRY

```
RECORDING(18TRACK|36TRACK|128TRACK|256TRACK|  
384TRACK|EFMT1|EFMT2|EEFMT2|UNKNOWN)
```

This shows the EEFMT2 subparameter associated with the RECORDING parameter for CREATE VOLUMEENTRY.

---

## EEFMT2 Support for DCOLLECT

The DCOLLECT command has values added to its definitions for DDRECTE to allow the constant DDCEEFM2 for EEFMT2 devices.

### EEFMT2 subparameter for DCOLLECT

```
DDRECTE(DDCRTNUL | DDC18TRK | DDC36TRK | DDC128TK | DDC256TK | DDC384TK |  
DDCEFMT1 | DDCEFMT2 | DDCEEFM2)
```

DDCEEFM2

The recording technology is EEFMT2. The constant value is 8.

---

## EEFMT2 Support for LISTCAT

The LISTCAT command is enhanced to display the new value associated with the RECORDING parameter for VOLUME entries.

## EEFMT2 subparameter in List tape volume entries sample output

```

LISTCAT -
  VOLUMEENTRIES
  ALL
IDCAMS  SYSTEM SERVICES                TIME: 11:29:12      09/02/05      PAGE      2
                                     LISTING FROM CATALOG -- SYS1.VOLCAT.V0

VOLUME-ENTRY----V0A2991
  DATA-VOLUME
  LIBRARY-----ATLIB02      RECORDING-----EEFMT2      ERROR-STATUS----NOERROR      CREATION-DATE-2002-04-02
                                MEDIA-TYPE-----MEDIAx      USE-ATTRIBUTE----SCRATCH      ENT-EJ-DATE----- (NULL)
  STORAGE-GROUP---*SCRCH*      COMPACTION----- (YES)      WRITE-PROTECTED--- (NULL)      LAST-MOUNTED----- (NULL)
  CHECKPOINT----- (NULL)      SP-ATTRIBUTE-----NONE      LAST-WRITTEN----- (NULL)
  LOCATION-----LIBRARY      SHELF-LOC----- (NULL)      EXPIRATION----- (NULL)
  OWNER----- (NULL)
IDCAMS  SYSTEM SERVICES                TIME: 11:29:12      09/02/05      PAGE      3
                                     LISTING FROM CATALOG -- SYS1.VOLCAT.VGENERAL
  THE NUMBER OF ENTRIES PROCESSED WAS:
    AIX -----0
    ALIAS -----0
    CLUSTER -----0
    DATA -----0
    GDG -----0
    INDEX -----0
    NONVSAM -----0
    PAGESPACE -----0
    PATH -----0
    SPACE -----0
    USERCATALOG -----0
    TAPELIBRARY -----0
    TAPEVOLUME -----1
    TOTAL -----1
  THE NUMBER OF PROTECTED ENTRIES SUPPRESSED WAS 0
IDC0001I FUNCTION COMPLETED, HIGHEST CONDITION CODE WAS 0
IDCAMS  SYSTEM SERVICES                TIME: 11:29:12      09/02/05      PAGE      4
IDC0002I IDCAMS PROCESSING COMPLETE. MAXIMUM CONDITION CODE WAS 0

```

**Note:** MEDIAx represents either MEDIA5, MEDIA6, MEDIA7, MEDIA8, MEDIA9, or MEDIA10.



---

## Chapter 30. Tape drive and tape volume allocation modifications for encryption-capable TS1120 tape drive

Changes made to device support, storage management subsystem (SMS), and Multiple Virtual Storage (MVS) device allocation enable you to allocate the tape drives and tape volumes. Within an IBM tape library environment, your system can fully recognize all supported media types and recording technologies. This topic explains these changes:

- “Device support modifications”
- “DD statement changes” on page 212
- “SMS modifications” on page 213
- “MVS device allocation modifications” on page 214

---

### Device support modifications

z/OS DFSMS device support provides hardware device-specific code, which allows tape drives, tape volumes, and DASD to interface with z/OS DFSMS. Specifically, it provides:

- The interfacing exits to the input/output supervisor (IOS) and EXCP device support code
- Error recovery procedure routines
- Services to acquire and log statistical and error data
- Services to acquire and display device states
- Utilities for functions like initializing tapes

You can use the MVS DEVSERV command to request basic status information on a device, a group of devices, or storage control units. You can use the QTAPE parameter of the DEVSERV command to display tape device information. Use DEVSERV QTAPE to display the real device type and the emulated device type.

With the DEVSERV QTAPE MED (medium) option, you can display information for the device type, media type, and cartridge volume serial number.

The syntax of the DEVSERV QTAPE command with the MED option is as follows:

```
DS QT,xxx,MED,nnn
```

*xxx*

Represents a three-digit or a four-digit device number in hexadecimal format.

*nnn*

Stands for the number of devices, starting at the address *xxx*, for which the DEVSERV command displays the MED information. The value *nnn* is optional and can be any decimal number from 1 to 256, with 1 as the default value.

Figure 21 on page 300 shows the display content when you issue the DEVSERV QTAPE MED command.

```

-----
----      DS QT MED Display Content      ----
-----

IEE459I          DEVSERV QTAPE
UNIT RDTYPE EDTYPE EXVLSR INVLSR RMEDIA EMEDIA WWID X

```

Figure 14. DEVSERV QTAPE MED display content

- X UNIT - tape device address
- RDTYPE - real device type
- EDTYPE - emulated device type
- EXVLSR - external volume serial of cartridge
- INVLSR - internal volume serial of cartridge
- RMEDIA - real media type of the volume mounted on the drive
- EMEDIA - emulated media type of the volume mounted on the drive
- WWID - world-wide identifier or world-wide unique cartridge identifier

**Note:**

1. EDTYPE, EXVLSR, INVLSR, RMEDIA, EMEDIA, and WWID are blank if information is not available.
2. Valid values for RMEDIA and EMEDIA are:
  - 1=CST
  - 2=EC-CST
  - 3=3590 STD length tape
  - 4=3590 EXT length tape
  - 5=3592 Enterprise Tape Cartridge
  - 6-W=3592 Enterprise WORM Tape Cartridge
  - 7=3592 Enterprise Economy Tape Cartridge
  - 8-W=3592 Enterprise Economy WORM Tape Cartridge
  - 9=3592 Enterprise Extended Tape Cartridge
  - 10-W=3592 Enterprise Extended WORM Tape Cartridge

RMEDIA and EMEDIA are blank when the media type is not defined or cannot be determined.

These examples show sample output and messages of the DEVSERV QTAPE command, and DEVSERV QTAPE with the MED option command.

Figure 15 shows the output of DS QT,962,MED when an encryption-capable 3592 Model E05 tape drive emulates a 3590 Model B1x tape drive.

```

IEE459I 11.32.31 DEVSERV QTAPE 608
UNIT RDTYPE EDTYPE EXVLSR INVLSR RMEDIA EMEDIA WWID
0962 3592-2E 3590-1          10-W 3 85804D003C00000BC211CA0C

```

Figure 15. DS QT,962,MED output

Figure 16 on page 209 shows the output of DS QT,940,MED when a non-encryption-capable 3592 Model E05 tape drive emulates a 3590 Model B1x tape drive.



```

IEE459I 11.32.31 DEVSERV QTAPE 608
UNIT RDTYPE EDTYPE EXVLSR INVLSR RMEDIA EMEDIA WWID
0940 3592-2 3590-1 003700          9      3

```

Figure 16. DS QT,940 output

Figure 17 shows the output of DS QT,960 when a 3592 Model E05 tape drive emulates a 3590 Model B1x tape drive.

```

IEE459I 17.04.39 DEVSERV QTAPE 502
UNIT DTYPE DSTATUS CUTYPE DEVTYPE CU-SERIAL DEV-SERIAL ACL LIBID
0960 3590 ON-RDY 3592J70 3592E05* 0178-09F8A 0178-09F8A

```

Figure 17. DS QT,DA0 output

Figure 18 displays the message that is issued when the input device address is valid, but the device is not a Model B1x, Model E1x, Model H1x, 3592 Model J, 3592 Model E05, or 3490E drive.

```

IEE459I 11.32.31 DEVSERV QTAPE 608
UNIT RDTYPE EDTYPE EXVLSR INVLSR RMEDIA EMEDIA WWID
**** UNLISTED DEVICE(S) AND REASON CODES :
0B60(10) Y
**** (10) - UNSUPPORTED DEVICE TYPE

```

Figure 18. DS QT,B60,MED message

**Y** Reason Code 10, UNSUPPORTED DEVICE TYPE, is shown when the device type given is not a Model B1x, Model E1x, Model H1x, 3592 Model J, 3592 Model E05, or 3490E drive.

Figure 19 shows the message and reason code 11 that you receive if the input device address and device type are valid, but the device is not ready.

```

IEE459I 11.32.31 DEVSERV QTAPE 608
UNIT RDTYPE EDTYPE EXVLSR INVLSR RMEDIA EMEDIA WWID
**** UNLISTED DEVICE(S) AND REASON CODES :
0DA0(11) Z
**** (11) - DEVICE NOT READY

```

Figure 19. DS QT,DA0,MED message

A bit DFVTCRYP is added to the IHADFVT mapping macro that maps the data facilities vector table. When set, it indicates that all of the software support for the encryption-capable 3592 Model E05 drive is on the system. This bit will be set by the enabling module IECTEPTF if it is installed.

System-wide DEVSUPxx parmlib member options control and manage media type selection for Automatic Tape Library (ATL) partitioning: MEDIA5=xxxx, MEDIA6=xxxx, MEDIA7=xxxx, MEDIA8=xxxx, MEDIA9=xxxx, and MEDIA10=xxxx where xxxx is a 4-digit hexadecimal category code.

The IECUCBCX mapping macro is changed to support the encryption-capable 3592 Model E05 tape drive. The EPI values are:

- X'13'--REALJAG2\_ENCRYPT

With MSGDISP macro interface, you can specify the message to be displayed and how to display it on magnetic tape devices that have displays. The parameter keyword, MEDIATYPE, can be used with the MOUNT and DEMOUNT keywords to indicate what media type to mount for scratch mounts on MTL devices. The value is specified as a quoted literal, unquoted literal, the address of a 1-byte field containing the value, or the name of the addressable field containing the value. Current valid values for MEDIATYPE are 1 through 10.

Currently there is a single byte limitation for the MEDIATYPE parameter keyword which passes an EBCDIC character representing the media type. This macro will be modified to allow specification of a value up to 10 via the MEDIATYPE keyword, but allowing for future media type values up to 255.

Valid and invalid specifications for MEDIA10 are described as follows:

**VALID specifications**

**Literal (unquoted)**

MEDIATYPE=10

**ADCON**

MEDIATYPE=A(HEX10) where HEX10 is defined as X'0A'

**Register**

MEDIATYPE=(3) where Reg 3 first has to be loaded with the address of HEX10 (e.g., LA R3,HEX10)

**RX Format**

MEDIATYPE=HEX10

**INVALID specifications**

**Quoted Literal**

MEDIATYPE='10'

**Unquoted Literal**

MEDIATYPE=A

**ADCON**

MEDIATYPE=A(CharA) where CharA is defined as EBCDIC 'A'

**Register**

MEDIATYPE=(3) where Reg 3 is first loaded with the address of CharA

**RX Format**

MEDIATYPE=CharA

## IOS000I Message with Encryption Failure

If an encryption-related key exchange between the drive and the key manager fails, an IOS000I message is issued indicating that an encryption failure has occurred:

```
IOS000I 07C2,7D,IOE,06,0600,,**,J1G150,ENCREADA 594
804008C022402751 0806FF0000131415 0017181900000092 2004E82061C42111
ENCRYPTION FAILURE
CU = 08 DRIVE = 131415 EKM = 171819
```

The control unit (CU), DRIVE, and Encryption Key Manager (EKM) error codes are from sense bytes 08, 13-15, and 17-19, respectively. For example:

```
IOS000I 0BD0,60,IOE,01,0E00,,**,JJC046,ATNCMP1
804C08C022402751 0001FF0000000000 0005EE3100000092 2004E82061BA2111
ENCRYPTION FAILURE
CU=00 DRIVE=000000 EKM=05EE31
```

In this example, the error was reported by the Encryption Key Manager (EKM).

For an EKM failure, refer to the Problem Determination section of the *IBM System Storage Tape Encryption Key Manager, Introduction, Planning, and User's Guide*, GA76-0418. When looking up the EKM failure, use the last two bytes of the error code (for example, EE31 in the example above).

For a control unit failure, refer to the *IBM System Storage TS1120 Tape Drive and Controller Operator Guide*, GA32-0556. Table 30 contains error codes for control unit failures.

Table 30. Error codes for control unit failures

Error code	Description	Recovery action
00	Not a control unit reported failure	Refer to the EKM and drive error codes reported in the IOS000I message for failure information.
01	The EKM was not available for an out-of-band key exchange.	Verify the EKM that the control unit is configured to use and also verify the state of that EKM. However, if the intent was to use in-band key management, use the EKM subcommand of the IECIOSxx PARMLIB member or the SETIOS command to specify your key manager(s).
02	Timeout for an out-of-band key exchange	The EKM may have gone down mid-sequence, or there may be a network problem. Verify the state of the EKM and the TCP/IP network. However, if the intent was to use in-band key management, use the EKM subcommand of the IECIOSxx PARMLIB member or the SETIOS command to specify your key manager(s).
03	An in-band key exchange was canceled by the host.	Check for an IOS628E message for further information as to why the in-band proxy may have canceled the key exchange. For additional information on these error codes, see <i>z/OS UNIX System Services Messages and Codes</i> .

The *IBM System Storage TS1120 Tape Drive SCSI Reference*, GA32-0562, lists the sense key, ASC, and ASCQ combinations that are reported for encryption conditions, along with a one-line description.

For more detailed information about the drive-reported conditions, and also about the EKM-reported conditions, see the Problem Determination section of the *IBM System Storage TS3500 Tape Library Operator Guide*, GA32-0560.

If there are multiple error codes reported, start with the EKM error code.

In addition, any system-managed tape library scratch tape that receives the IOS000I ENCRYPTION FAILURE message along with an IEC512 I/O ERR, remains in a scratch status, but is updated in the Tape Control Data Base (TCDB) with a VOLUME ERROR STATUS of I/O ERROR. This causes it to be placed in the software error category, and the tape is unusable until the I/O ERROR condition is cleared through manual intervention (for example, use ISMF volume ALTER from scratch. Scratch moves the volume from the software error category back to the scratch category). Periodically, use the DISPLAY SMS,LIBRARY command with DETAIL to display the number of scratch volumes in the software error category.

## DD statement changes

This topic describes the changes to the DD statement in support of the encryption-capable TS1120 tape drive tape drive.

Use the DATACLAS parameter to specify a data class for a new data set. The storage administrator at your installation defines the names of the data classes you can code on the DATACLAS parameter. These keyword parameters (data class parameters) are added to the DD statement:

- KEYLABL1
- KEYLABL2
- KEYENCD1
- KEYENCD2

### Parameter field

Keyword parameter	Value	Purpose
KEYLABL1='mykeylabel1'	1- 64 characters	Specifies the label for the key encrypting key used by the Encryption Key Manager. The key encrypting key is used to encrypt the data (encryption) key.
KEYLABL2='mykeylabel2'	1- 64 characters	Specifies the label for the key encrypting key used by the Encryption Key Manager. The key encrypting key is used to encrypt the data (encryption) key.
KEYENCD1=L H	1 character L = label H = public key hash	Specifies how the label for the key encrypting key specified by the key label 1 is encoded by the Encryption Key Manager and stored on the tape cartridge.
KEYENCD2=L H	1 character L = label H = public key hash	Specifies how the label for the key encrypting key specified by the key label 2 is encoded by the Encryption Key Manager and stored on the tape cartridge.

### Overrides

Any data set attributes you specify on the new DD parameters override the corresponding attributes in the data class for the data set:

- KEYLABL1 (key label 1)
- KEYENCD1 (encoding for key label 1)
- KEYLABL2 (key label 2)
- KEYENCD2 (encoding for key label 2)

---

## SMS modifications

SMS automates and centralizes storage management. It automatically assigns service requirements and attributes to data when that data is created. SMS configuration services validate, for example, the recording technology value that ISMF specifies in data class definitions.

MEDIA9 and MEDIA10 will only be supported from z/OS DFSMS V1R5 and above.

SMS will support a new recording technology EEFMT2

In an IBM tape library environment (automated or manual), use ISMF to specify the:

- EFMT1 recording technology attribute
- EFMT2 recording technology attribute
- EEFMT2 recording technology attribute
- Media type of MEDIA5, MEDIA6, MEDIA7, MEDIA8, MEDIA9, or MEDIA10
- Performance scaling or performance segmentation option, if the media type is MEDIA5 or MEDIA9. Media types MEDIA6, MEDIA7, MEDIA8, and MEDIA10 are not scalable or segmentable.

The recording technology attribute and the performance scaling or performance segmentation options can also be specified and used outside of the system-managed tape library environment.

In support of the encryption-capable 3592 Model E05 tape drives, SMS configuration services are updated to validate the recording technology value EEFMT2 and are also updated to handle the new key label-related information.

### In Data Class

With SMS, the system obtains information about the attributes of a data set from the data class for the data set.

Any data set attributes you specify on these new DD parameters override the corresponding attributes in the data class for the data set:

- KEYLABL1 (key label 1)
- KEYENCD1 (encoding for key label 1)
- KEYLABL2 (key label 2)
- KEYENCD2 (encoding for key label 2)

### Overriding Attributes Defined in the Data Class

For a new data set, you can override the data class attributes defined in the data class for the data set by coding one or more of these new DD parameters:

- KEYLABL1 (key label 1)
- KEYENCD1 (encoding for key label 1)
- KEYLABL2 (key label 2)
- KEYENCD2 (encoding for key label 2)

## MVS device allocation modifications

MVS device allocation helps prioritize and select tape drives to meet the needs of application programs or system functions. Batch (JCL) or dynamic (SVC99) allocation makes these device needs known to MVS device allocation. MVS device allocation selects the appropriate devices and serializes them for the requester to use. It can also request that appropriate volumes be mounted on the allocated devices. It accomplishes these tasks by interfacing with SMS, DEVSERV, OAM, MSGDISP, and other system components.

MVS device allocation currently supports multiple types of tape devices. Within an IBM tape library environment, MVS device allocation considers media types and recording technologies when allocating tape drives and tape volumes. The dynamic allocation (SVC 99) volume interchange text unit (DALINCHG) allows you to specify EFMT1 for the recording technology and MEDIA5, MEDIA6, MEDIA7, or MEDIA8 for the media type and EFMT2 or EEFMT2 for the recording technology and MEDIA5, MEDIA6, MEDIA7, MEDIA8, MEDIA9 and MEDIA10 for the media type. Specification of MEDIA9 or MEDIA10 is only supported on z/OS V1R5 and above.

See Table 31 for DALINCHG parameter values.

*Table 31. Dynamic allocation (DALINCHG) parameter values for tape cartridge media types*

Parameter value	Media type	Recording technology
85	MEDIA5	EEFMT2
75	MEDIA5	EFMT2
65	MEDIA5	EFMT1
05	MEDIA5	No format
86	MEDIA6	EEFMT2
76	MEDIA6	EFMT2
66	MEDIA6	EFMT1
06	MEDIA6	No format
87	MEDIA7	EEFMT2
77	MEDIA7	EFMT2
67	MEDIA7	EFMT1
07	MEDIA7	No format
88	MEDIA8	EEFMT2
78	MEDIA8	EFMT2
68	MEDIA8	EFMT1
08	MEDIA8	No format
89	MEDIA9	EEFMT2
79	MEDIA9	EFMT2
09	MEDIA9	No format
8A	MEDIA10	EEFMT2
7A	MEDIA10	EFMT2
0A	MEDIA10	No format

### Related reading:

- See *z/OS MVS System Commands* for more information on the DEVSERV QTAPE command.
- See *z/OS MVS Programming: Authorized Assembler Services Guide* for more information about the DALINCHG parameter.
- See *z/OS DFSMS Installation Exits* for more information about the IECUCBCX mapping macro.

## JCL DD statement parameters and equivalent text units for TS1120

Use this table to convert a JCL DD statement into dsname allocation text units. The table lists JCL DD statement parameters in alphabetical order, along with the equivalent verb code 01 text unit key and mnemonic. Some JCL DD statement parameters have multiple text unit keys associated with them. In these cases, the same JCL DD statement is repeated in the table for each text unit key associated with it.

Table 32. JCL DD Statement Parameters and Equivalent Text Units

JCL DD statement parameter	Text unit mnemonic	Text unit key	Described in:
KEYENCD1	DALKYC1	8025	"Key Encode 1 Specification - Key = '8025'" on page 216
KEYENCD2	DALKYC2	8026	"Key Encode 2 Specification - Key = '8026'" on page 216
KEYLABL1	DALKYL1	8023	"Key Label 1 Specification - Key = '8023'" on page 216
KEYLABL2	DALKYL2	8024	"Key Label 2 Specification - Key = '8024'" on page 216

**Note:** References to previous DD statements are not supported.

## DSNAME Allocation Text Units for TS1120

Most of the information that can be specified on a JCL DD statement can also be specified in text units for the dsname allocation function (verb code '01'). These text units are listed in Table 33 and described on the pages that follow.

Table 33. Verb code 01 (dsname allocation) – text unit keys, mnemonics, and functions

Hex text Unit key	Mnemonic	Dsname allocation function
8023	DALKYL1	Specifies the label for the key encrypting key used by the Encryption Key Manager. The key encrypting key is used to encrypt the data (encryption) key.
8024	DALKYL2	Specifies the label for the key encrypting key used by the Encryption Key Manager. The key encrypting key is used to encrypt the data (encryption) key.
8025	DALKYC1	Specifies how the label for the key encrypting key specified by DALKYL1 for this DD is to be encoded by the Encryption Key Manager and stored on the tape cartridge.
8026	DALKYC2	Specifies how the label for the key encrypting key specified by DALKYL2 for this DD is to be encoded by the Encryption Key Manager and stored on the tape cartridge.

## Key Label 1 Specification - Key = '8023'

DALKYL1 specifies the label for the key encrypting key used by the Encryption Key Manager. The key encrypting key is used to encrypt the data (encryption) key. When you code this key, # must be one, LEN is the length of the key label, up to a maximum of 64, and PARM contains the key label.

**Example:** To specify the key label in DALKYL1 as "KEY.LABEL1", code:

```
KEY   #     LEN   PARM
8023  0001  000A  D2 C5 E8 4B D3 C1 C2 C5 D3 F1
```

## Key Label 2 Specification - Key = '8024'

DALKYL2 specifies the label for the key encrypting key used by the Encryption Key Manager. The key encrypting key is used to encrypt the data (encryption) key. When you code this key, # must be one, LEN is the length of the key label, up to a maximum of 64, and PARM contains the key label.

**Example:** To specify the key label in DALKYL2 as "KEY.LABEL2", code:

```
KEY   #     LEN   PARM
8024  0001  000A  D2 C5 E8 4B D3 C1 C2 C5 D3 F2
```

## Key Encode 1 Specification - Key = '8025'

DALKYC1 specifies how the label for the key encrypting key specified by DALKYL1 for this DD is to be encoded by the Encryption Key Manager and stored on the tape cartridge. When you code this key, # must be one, LEN must be one, and PARM contains either an "H" or an "L", as follows:

H: DALKYL1 is encoded as a hash of the public key.

L: DALKYL1 is encoded as the key label.

**Example:** To specify that the key label in DALKYL1 is encoded via hash ("H"), code:

```
KEY   #     LEN   PARM
8025  0001  0001  C8
```

## Key Encode 2 Specification - Key = '8026'

DALKYC2 specifies how the label for the key encrypting key specified by DALKYL2 for this DD is to be encoded by the Encryption Key Manager and stored on the tape cartridge. When you code this key, # must be one, LEN must be one, and PARM contains either an "H" or an "L" as follows:

H: DALKYL2 is encoded as a hash of the public key.

L: DALKYL2 is encoded as the key label.

**Example:** To specify that the key label in DALKYL2 is encoded via hash ("H"), code:

```
KEY   #     LEN   PARM
8026  0001  0001  C8
```

---

## Verb Code 01 - Non-JCL Dynamic Allocation Functions for TS1120

### Volume Interchange Specification - Key = '006F'

DALINCHG specifies the media type and track recording technique required for system-managed tape library allocation. Whenever possible, IBM suggests that you use an installation-defined DATACLAS construct name to control cartridge media



type and track recording technique. Use this key only when it is not possible to use a pre-defined DATACLAS construct because of the dynamic nature of the program and because the program must control the media type and track recording technique. Contact your storage administrator before using this key.

**Note:** To specify DALINCHG, your program must be APF-authorized, in supervisor state, or running in PSW key 0-7. The specification of DALINCHG will be ignored if a non-system-managed tape volume is allocated.

When you code this key, # and LEN must be one. These PARM values are new:

- 85 3592 Enterprise Tape Cartridge requested; Enterprise Encrypted Format 2 recording technology requested.
- 86 3592 Enterprise WORM Tape Cartridge requested; Enterprise Encrypted Format 2 recording technology requested.
- 87 3592 Enterprise Economy Tape Cartridge requested; Enterprise Encrypted Format 2 recording technology requested.
- 88 3592 Enterprise Economy WORM Tape Cartridge requested; Enterprise Encrypted Format 2 recording technology requested.
- 89 3592 Enterprise Extended Tape Cartridge requested; Enterprise Encrypted Format 2 recording technology requested.
- 8A 3592 Enterprise Extended WORM Tape Cartridge requested; Enterprise Encrypted Format 2 recording technology requested.

---

## MVS Data Areas

These data areas have been updated:

- IEFSIOTX
- IEFSJDKY
- IEFZB4D2
- JFCB
- SJKEY



---

## Chapter 31. ISMF modifications for encryption-capable TS1120 tape drive

In ISMF, these applications are modified to support tape subsystem encryption (new recording technology and new key labels):

- Data class define and alter panels
- Mountable tape volume list panel

### Related reading:

- See *z/OS DFSMS OAM Planning, Installation, and Storage Administration Guide for Tape Libraries* for additional information on the ISMF tape library management application.
- See *z/OS DFSMSdfp Storage Administration* for additional information about data classes and the ISMF data class panels.

---

### Data class define and alter panels for TS1120

A data class is a set of data set allocation attributes and associated values. You can define, alter, display, and list a data class by using the ISMF data class panels. In addition to the previously available values, you can now specify the EE2 value for the recording technology attribute EEFMT2 on the data class define/alter panel. A new panel is displayed for the user to enter the Key Labels and Encoding Mechanisms. The existing Performance Scaling and Performance Segmentation data class options, applicable with MEDIA5 and MEDIA9, can also be used with the new encryption format EEFMT2.

Key specification terminology:

#### Key Label

Specifies the label for the key encrypting key used by the Encryption Key Manager. The key encrypting key is used to encrypt the data (encryption) key.

The key label value can be specified up to 64 characters containing alphanumeric, national or special characters with some additional characters also being allowed. It is treated as a free form field on input and validity checked by the control unit when the key label is first used and converted from EBCDIC to ASCII. The characters specified through ISMF must map to ASCII characters X'20' to X'7E'.

#### Encoding Mechanism

Specifies how the label for the key encrypting key specified by the key label (input) is encoded by the Encryption Key Manager and stored on the tape cartridge.

- **L** = encoded as the specified label
- **H** = encoded as a hash of the public key

---

### Mountable tape volume list panel

On the mountable tape volume list, the value EEFMT2 can appear in column 9, RECORDING TECHNOLOGY.



---

## Chapter 32. OCE modifications for encryption-capable TS1120 tape drive

The z/OS DFSMS Open/Close/End-of-Volume (OCE) component is a set of system routines that builds the control block structure that connects the application, access method, and the operating system. OCE modifications for the encryption-capable TS1120 tape drive include support for the EEFMT2 encryption technology and passing encryption key information to the tape drive.

### Related reading:

- See *z/OS DFSMS Using Data Sets* and *z/OS DFSMS Using Magnetic Tapes* for additional information about the OCE routines.
- See *z/OS DFSMS Installation Exits* for more information on OCE installation exit parameter lists.
- See *z/OS DFSMS OAM Planning, Installation, and Storage Administration Guide for Tape Libraries* for more information on tape volume records.
- See Chapter 56, “OCE modifications for 3592 Model J,” on page 385 for more information on the existing WORM tape support.
- See *z/OS MVS System Messages, Vol 7 (IEB-IEE)* for more information on message IEC205I.

---

## Overview

Tape subsystem encryption is supported through a hardware encryption feature of the encryption-capable TS1120 tape drive. This encryption feature requires both hardware and microcode updates. MEDIA5 - MEDIA10 support a recording format EEFMT2 (encrypted) in addition to EFMT1 and EFMT2. EEFMT2 is compatible with both performance segmentation and performance scaling. EFMT2 is the default recording technology. EEFMT2 and EFMT1 must be requested through SMS data class. When EEFMT2 is requested, OPEN passes the key encoding mechanism and key labels obtained from SMS to the drive. The key labels are used by the Encryption Key Manager (EKM) to create externally encrypted data keys (EEDKs) which are stored on the cartridge in drive-only accessible areas.

---

## SMS Managed Tape

An SMS managed cartridge Tape Volume Record (TVR) in the tape configuration data base (TCDB) is updated by OPEN and EOVS with the EEFMT2 recording technology when the TVR is opened for OUTPUT, DISP=NEW to the first file (beginning of tape).

---

## Recording Technology Conflict

OPEN and EOVS resolve the recording technology conflicts when an EEFMT2 formatted cartridge is mounted on 3592 Model J1A or on a non-encryption enabled 3592 Model E05. If the volume serial in sense facility is active (such as VOLNSNS=YES is specified in DEVSUPxx), the load point volume label structure is rewritten by the existing volume serial number obtained from the returned sense data.

---

## Multiple Recording Format Capability

For both system managed and standalone environments, during OPEN OUTPUT, file sequence 1, DISP=NEW, OPEN retrieves the assigned data class to determine these situations:

- If EFMT1 or EEFMT2 is requested.
- If the default EFMT2 is to be used.

For the prevailing recording format, OPEN issues a command to the drive to enable the recording format from the load point.

**Note:** When the tape is written from load point, OPEN OUTPUT and EOV issues a command to the drive for the existing/prevailing recording technology.

---

## Encryption and Key Labels

During the OPEN processing, when a data set is opened for OUTPUT, file sequence 1, DISP=NEW, if an encryption enabled 3592 Model E05 is allocated and the assigned data class indicates EEFMT2, the OPEN processing obtains the key encrypting key (KEK) labels and the key encoding mechanism (label or hash) by using SMS services. OPEN passes the KEK labels and key encoding type to the drive. If this key label-related information is not specified, OPEN does not pass any key label-related information. This operation results in using the defined Encryption Key Manager (EKM) established defaults. For the encrypted cartridges, DISP=OLD (and also DISP=SHR) and file sequence 1 (reuse from loadpoint), the OPEN processing directs the drive to

- reuse the existing KEK labels and to use the encryption recording format (EEFMT2) .

Encryption is supported for SL (IBM standard), AL (ANSI standard), NL (no labels) and NSL (non standard). For labeled tapes (SL- IBM standard or AL - ANSI standard), OPEN indicates to the drive that a key known to all encryption capable 3592 drives is to be used for the load point volume label.

It is during OPEN processing (file sequence 1, open for OUTPUT) where the key exchange between the drive and the encryption key manager (EKM) takes place, and it is also the point in time in which the drive writes the EEDK structures on the tape. As a result of these encryption-related activities, expect more time to be spent in OPEN processing with more time appearing between the mount message and the tape on (IEC705I) message.

OPEN sets the IEZDEB bit DEB2XEEF to indicate cartridge is encrypted.

It is also during OPEN processing where an indicator is sent to the control unit to indicate whether in-band or out-of-band key management should be used.

During the CLOSE processing, for an encrypted volume, the key encrypting key (KEK) labels and encoding mechanism are passed to the File End on Volume tape installation exit. Therefore, the tape management system can record the key labels associated with the volume. CLOSE processing obtains the key labels from the drive to pass them to the tape management system through the File End on Volume Tape Installation Exit.

During the EOV processing, for an encrypted volume, the key encrypting key (KEK) labels and the key encoding method are obtained from the drive to ensure

that the same encryption information applies to each volume of the multi-volume data set and passes this information to the drive on the subsequent mount.

In these situations, no additional changes are needed (other than to indicate in-band or out-of-band key management). The drive automatically detects that the volume is encrypted and initiates a key request with the Encryption Key Manager to have the externally encrypted data key (EEDK) decrypted.

- When an existing data set is opened for INPUT (read).
- When an existing data set is opened for OUTPUT and appended (DISP=MOD).
- When an additional file sequence is written to the volume.

The key labels and encoding type are stored in an extended information segment type 7 of the SMF14/15 record. This output is the macro for the SMF14/15 change:

```

*          THIS DESCRIBES THE KEK LABELS AND ENCODING
*          MECHANISMS FOR A TAPE DATA ENCRYPTED DATA SET.
*          THIS SECTION HAS A TYPE OF 7.
*
SMF14ENC EQU *          TAPE ENCRYPTION DATA SECTION
SMF14KL1 DS  CL64' '    KEY LABEL 1
SMF14CD1 DS  CL1' '     ENCODING MECHANISM FOR KEY LABEL 1
SMF14KL2 DS  CL64' '    KEY LABEL 2
SMF14CD2 DS  CL1' '     ENCODING MECHANISM FOR KEY LABEL 2

```

In addition to these SMF 14/15 fields, APAR OA19502 added the field SMF14KET. This field displays the key exchange time in hundredths of seconds. The key exchange (encryption overhead) time is only applicable for the SMF 15 output record and only for non-parallel open processing when writing file sequence 1 from loadpoint. Otherwise this value is set to zero.

---

## Media Support

The OCE routines also include the IFGTPE macro with several fields for mapping installation exit parameter lists. Values that can be returned are: EFMT1, EFMT2, and EEFMT2 in TEPMRECTK recording technology, MEDIA5, MEDIA6, MEDIA7, MEDIA8, MEDIA9 and MEDIA10 in TEPMMEDT media type.

---

## OCE Tape Installation Exits

The IFGTPE macro maps the tape log data. Table 34 describes the IFGTPE fields for mapping the installation exit main parameter list.

*Table 34. IFGTPE fields for the installation exit main parameter list*

Field name	Length and type	Description
TEPMRECTK	8 (integer)	Recording technology of the mounted volume in binary. 8 - EEFMT2
TEPMMEDT	8 (integer)	Media type of the mounted volume in binary.

The IFGTPE macro maps the tape log data. Table 35 on page 224 describes the IFGTPE fields for mapping the installation exit file end on volume parameter list.

Table 35. IFGTEP fields for the installation exit file end on volume parameter list

Field name	Length and type	Description
TEPEKEK1	64 (character)	KEK label 1
TEPEKEK2	64 (character)	KEK label 2
TEPEKCD1	1 (character)	Key encoding mechanism associated with KEK label 1: L - Label, H - Hash
TEPEKCD2	1 (character)	Key encoding mechanism associated with KEK label 2: L - Label, H - Hash

**Note:**

1. The version of the FILEE parameter list (TEPEVER) is also updated (to a 2) to accommodate the longer FILEE parameter list.
2. For a given mount, the tape drive obtains (from the Encryption Key Manager) and stores the key management-related information for subsequent access. When returning this information to the drive, if the encoding mechanism for one or both of the EEDKs is a "hash", the Encryption Key Manager always tries to resolve the "hash" value in an EEDK to its corresponding key label value and returns only the hash value if the key label cannot be resolved.
3. If the returned key label from the Encryption Key Manager is only available as a hash value, the control unit automatically converts the returned hash value to printable EBCDIC and returns this value as the 64-CHAR key label (padded on the right with blanks X'40'). The returned hash value can be up to 56 bytes in length. This value is then passed to the file end on volume exit along with the character string \*HASH\* appended to the end of the character string in bytes 59-64. For example:

```
ABDCFAABF15698BCDE222156AB4589BEFCDE9009ACBECCA12345678A *HASH*
```

---

## OCE Messages

During OPEN processing, when a data set is opened for OUTPUT, existing message IEC205I externalizes each Key Label and the associated encoding mechanism. If the returned key label is a hash value, \*HASH\* is appended to the returned value.

The returned encoding mechanism indicates how the key label is recorded by the encryption key manager (EKM) and stored on the tape cartridge. It does not necessarily reflect how the key label itself is being returned and displayed in the key label fields. If an encoding mechanism of "hash" is used, the encryption key manager (EKM) will always try and return its associated key label, and only if it can't, will a "hash" value be returned and displayed in the IEC205I message.

This is an example of the IEC205I message:

```
IEC205I SYSUT2,ATNCMP1,STEP1,FILESEQ=1, COMPLETE VOLUME LIST,
DSN=ATL.TESTJOB.EE2,VOLS=J11986,
LISTED VOL(S) HAVE BEEN DATA ENCRYPTED,KL1CD:L,KL2CD:L,
KL1=dfsmskeylabel1,KL2=dfsmskeylabel2,TOTALBLOCKS=1
```



---

## OCE Encryption Abends

During OPEN and EOVS processing, errors associated with encryption support result in OPEN IEC147I 613-88 or EOVS IEC026I 637-88.

- 613-88 encryption IO error during OPEN.
- 637-88 encryption IO error during EOVS.

During OPEN processing, existing IEC147I, abend code 613-84, is enhanced to also account for an up-level recording format. This abend code is also issued if an encrypted volume is being used on a down-level system that does not have all of the encryption support installed.

- 613-84 no software support for the media type or the recording technology.

During CLOSE processing, errors associated with encryption support will result in CLOSE IEC211I 314-10.

- 314-10 encryption IO error during CLOSE.



---

## Chapter 33. DFSMSHsm considerations for the encryption-capable TS1120 tape drive

DFSMSHsm, a z/OS functional component, automatically manages low activity and inactive data in both system-managed and non-system-managed environments. DFSMSHsm also provides automatic backup and recovery of active data in those environments.

DFSMSHsm can use the encryption-capable TS1120 tape drive (3592 Model E05, 3592-2E) for all functions. DFSMSHsm normally uses non-WORM media (MEDIA5, MEDIA7, MEDIA9) for non-ABARS functions. DFSMSHsm uses all media, including WORM (MEDIA6, MEDIA8 and MEDIA10) for ABARS processing. DFSMSHsm can use the WORM media for non-ABARS processing if specifically allowed by your installation.

This topic describes these considerations for using DFSMSHsm with the encryption-capable TS1120 tape drive:

- “Modifying your SMS data classes”
- “Modifying your dump classes”
- “Input tape utilization” on page 228
- “Requesting information for encrypted volumes and tapes” on page 228
- “Requesting information for dump volumes” on page 229
- “Specifying esoteric tape unit names to DFSMSHsm” on page 230
- “Tape Hardware Emulation” on page 230
- “Specifying how much of a tape DFSMSHsm uses” on page 230
- “Using tape device naming conventions” on page 231
- “Output tape selection” on page 231
- “Output tape utilization” on page 232
- “Allowing DFSMSHsm to use the 3590-1 generic unit when it contains mixed track technology drives” on page 232
- “Recovering overwritten encrypted tapes” on page 233
- “DFSMSHsm tips” on page 233.

---

### Modifying your SMS data classes

To use tape hardware encryption, you must modify your SMS data class definitions to request encryption from the encryption-capable tape drives.

---

### Modifying your dump classes

With the support for the encryption-capable TS1120 tape drive, hardware encryption joins software (or host-based) encryption as another means of encrypting your installation's dump data. As a result, the method for requesting encryption now depends on whether you plan to use hardware encryption or host-based encryption, as follows:

- To request hardware encryption for a dump class, specify it in the SMS data class for the dump data.
- To request host-based encryption for a dump class, use the DFSMSHsm DEFINE DUMPCLASS(ENCRYPT) command. With ENCRYPT, include the RSA or KEYPASSWORD subparameters to specify the type of host-based encryption. ENCRYPT(NONE) specifies host-based encryption should not be done.

If your dump classes are currently defined to use host-based encryption (and possibly host-based compression before encryption), it is recommended that you remove the host-based encryption requests from any dump classes for which you plan to use tape hardware encryption.

During the process of migrating your dump classes to use hardware encryption, you might have some dump classes that are still defined to use host-based encryption, while their associated SMS data classes are defined to use tape hardware encryption. Here, DFSMSdss ignores requests for host-based encryption for these tape volumes and, instead, uses hardware encryption. This processing allows you to complete the migration to hardware encryption without having to modify your dump-requesting jobs. However, removing host-based encryption requests from a dump class when tape hardware encryption is also requested can avoid confusion concerning which process is active.

**Note:**

1. To determine whether hardware encryption or host-based encryption was used for a particular tape volume, check the associated dump volume record (DVL).
2. If more than one dump class is specified (creating more than one dump copy), those dump classes specify host-based encryption, each dump class has a unique data class assigned, and some but not all of the associated data classes request tape hardware encryption, then all dump copies will fail. In other words, tape hardware encryption can override host-based encryption for all dump classes associated with a source volume or none of the dump classes, but it cannot override a subset of those dump classes.

**Related reading:**

- For more information on the DEFINE DUMPCLASS command, see *z/OS DFSMSdss Storage Administration*.

---

## Input tape utilization

DFSMSHsm can use MEDIA5, MEDIA6, MEDIA7, MEDIA8, MEDIA9, and MEDIA10 as input.

In an SMS environment, the choice of an input drive for a particular tape is controlled by the library and is transparent to DFSMSHsm.

In a non-SMS environment, the choice of drives is controlled by the unit name recorded in the tape's CDS records. This unit name is the name of the original output unit selected by the installation, or its generic equivalent. In a mixed non-SMS environment where more than one tape technology is associated with a generic unit name, you must use esoteric names for the output unit and its associated input unit.

You can use MEDIA5, MEDIA7, and MEDIA9 tapes as input for all DFSMSHsm functions. Besides these media types, you can also use MEDIA6, MEDIA8, and MEDIA10 tapes for ABARS processing.

---

## Requesting information for encrypted volumes and tapes

New values EEFMT2, ENCRYPTION (or ENCRYPTED), and NOENCRYPTION (or NOTENCRYPTED) are added to the SELECT parameter of the DFSMSHsm LIST TTOC command to allow you to list tape volumes with and without tape hardware encryption.

This shows a portion of the syntax for the LIST TTOC command:

**N: TTOC SELECT Optional Parameters:**

NOALTERNATEVOLUME
FAILEDRECYCLE
EXCESSIVEVOLUMES
FAILEDCREATE
DISASTERALTERNATEVOLUMES
ALTERNATEVOLUME
RECALLTAKEAWAY
CAPACITYMODE
EMFT1
EMFT2
EEFMT2
ENCRYPTION
NOENCRYPTION

**Related reading:**

For more information on the LIST TTOC command, see *z/OS DFSMSdfp Storage Administration*.

## Displaying EEFMT2 formatted volumes

You can use the LIST TTOC command to list volumes based on the recording technology used. To list all volumes recorded in EEFMT2 format, enter the LIST TTOC command as follows:

```
LIST TTOC SELECT(EEFMT2) ODS(ttoc.out.dataset)
```

## Displaying encrypted tape volumes

You can use the LIST TTOC command to list tape volumes that were encrypted through hardware encryption. To do so, enter the LIST TTOC command as follows:

```
LIST TTOC SELECT(ENCRYPTION) ODS(ttoc.out.dataset)
```

You can also use the LIST TTOC command to list tape volumes that were not encrypted through hardware encryption. To do so, enter the LIST TTOC command as follows:

```
LIST TTOC SELECT(NOENCRYPTION) ODS(ttoc.out.dataset)
```

---

## Requesting information for dump volumes

For a list of the information for a specific dump volume managed by DFSMSHsm, specify the LIST command with the DUMPVOLUME(*volser*) parameter. If the volume was tape hardware encrypted, the ENC field will indicate THW.

For a list of the information for the dump volumes of the requested status managed by DFSMSHsm, specify the LIST command with the DUMPVOLUME parameter without the volume serial number. Instead, include a status parameter such as AVAILABLE, UNAVAILABLE, EXPIRED, UNEXPIRED, or NORETENTIONLIMIT. The command lists the volumes in alphanumeric sequence by volume serial number.

**Related reading:**

For more information on the LIST DUMPVOLUME command, see *z/OS DFSMSdfp Storage Administration*.

---

## Specifying esoteric tape unit names to DFSMSHsm

When using the SETSYS USERUNITTABLE command to specify esoteric tape unit names to DFSMSHsm, note that DFSMSHsm rejects mixed combinations of device names in an esoteric group, with these exceptions:

- You can have a mix of 3480 and 3480X device names in the same esoteric group. You cannot, however, use Improved Data Recording Capability (IDRC) with such a group because all devices are treated as 3480s.
- You can have a mix of 3592-1, 3592-2 and 3592-2E device names in the same esoteric group. Here, you must ensure that the drives in the esoteric group can write using the same recording technology. For example, if you include a 3592-1 drive, all other drives in the esoteric must use EMFT1 for output. If the esoteric mixes 3592-2 and 3592-2E drives, all drives must be set-up to use EFMT1 or EFMT2 recording technology.

### Note:

1. If an esoteric group associated only with 3480Xs exists, 3480s should not be added to it, because the data already written using this esoteric tape unit name might create IDRC incompatibilities.
2. If DFSMSHsm rejects an esoteric tape unit name, it does not reject the rest of the valid esoteric names specified in the USERUNITTABLE command. Each time you specify USERUNITTABLE, the valid esoteric tape unit names identified with this parameter replace any esoteric tape unit names identified through a previous use of the SETSYS USERUNITTABLE command.

### Related reading:

- For more information on the SETSYS command, see *z/OS DFSMSdfp Storage Administration*.

---

## Tape Hardware Emulation

- An encryption-capable TS1120 or 3592-E05 tape drive always runs in emulation mode as a 3590-B1x tape drive.
- The 3590-E1x, 3590-H1x, and the 3592-J1A drives emulate either a 3490-E1x or 3590-B1x.

---

## Specifying how much of a tape DFSMSHsm uses

**For 3592 devices:** If your installation requires very fast access to data on a MEDIA5 or MEDIA9 tape, consider using the 3592 performance scaling feature. In DFSMSHsm, performance scaling applies in both tape libraries and standalone environments.

Performance scaling uses 20% of the physical space on each tape and keeps data sets closer together and closer to the initial load point. Performance scaling permits the same amount of data to exist on a larger number of tapes, allowing more input tasks to run concurrently. With performance scaling, you can effectively increase the "bandwidth" of operations that read data in from tape.

In contrast, performance segmentation allows the use of most of the physical media, while enhancing performance for the first and last portions of the tape.

### Related reading:

- For more information about implementing DFSMSHsm tape environments, see *z/OS DFSMSdfp Storage Administration*.

---

## Using tape device naming conventions

Table 36 shows the hardware (marketing device name) and software (MVS generic device name) names for 3592 tape devices. The MVS generic device names are also the names used by the job control language (JCL) to communicate with the z/OS operating system. Use the MVS generic name or your installations esoteric name in any JCL statements or DFSMSHsm commands that specify device names.

Table 36. Tape device naming conventions

Device description	Hardware name	Generic MVS name
<b>3592-2E</b> <ul style="list-style-type: none"><li>Enterprise recording format: EFMT1, EFMT2, EEFMT2</li><li>IBM TotalStorage Enterprise tape cartridge (MEDIA5, MEDIA6, MEDIA7, MEDIA8, MEDIA9, MEDIA10)</li><li>Always in “emulation mode” as a 3590 Model B device.</li></ul>	<b>3592-E05</b>	<b>3590-1</b>
<b>3592-2</b> <ul style="list-style-type: none"><li>Enterprise recording format: EFMT1, EFMT2</li><li>IBM TotalStorage Enterprise tape cartridge (MEDIA5, MEDIA6, MEDIA7, MEDIA8, MEDIA9, MEDIA10)</li><li>Always in “emulation mode” as a 3590 Model B device.</li></ul>	<b>3592-E05</b>	<b>3590-1</b>

---

## Output tape selection

DFSMSHsm can select encryption-capable TS1120 tape drives (3592-2E) for output in SMS and non-SMS tape environments. DFSMSHsm performs all of its allocation requests through these standard dynamic allocation interfaces:

### Output to Scratch Tapes

The 3592-2E tape drive is selected through data class or DALINCHG in an SMS environment and through an esoteric or generic unit name in a non-SMS environment.

The new EEFMT2 format is selected through data class or DALINCHG in an SMS environment. In a non-SMS environment only data class can be used to select EEFMT2.

An empty MEDIA9 or MEDIA10 tape cannot be selected for output on a 3592-1 tape drive.

### Output to Partial Tapes

When the 3592-2E uses a partial tape for output, the tape might have been written in the EFMT1, EFMT2, or EEFMT2 recording formats. It is then extended in the same format. MEDIA9 and MEDIA10 partial tapes are always recorded using EFMT2 or EEFMT2 technology.

The 3592-1 and 3592-2 might also use these partial tapes. If a tape was initially written by a 3592-2E, it might have been written in the EFMT1, EFMT2, or

EEFMT2 recording formats. If the tape was written in EFMT1, it can be selected by a 3592-1 for extension. If the tape was written in EFMT1 or EFMT2, it can be selected by a 3592-2 for extension.

---

## Output tape utilization

DFSMSHsm writes to 97% of the capacity of MEDIA5, MEDIA6, MEDIA7, MEDIA8, MEDIA9, and MEDIA10 tapes unless otherwise specified by the installation. Other percentages can be specified through the SETSYS TAPEUTILIZATION command, depending on the particular needs of the installation. DFSMSHsm uses the reported cartridge type on the physical device to determine the tape's capacity.

## ACS Routines

Because the 3592-2E can write in three recording formats (EFMT1, EFMT2 or EEFMT2), you must modify your installation's ACS routines to select the recording format to be used on empty media (through the data class assigned to the tape) if you want the 3592-2E drives to use EFMT1 or EEFMT2.

For duplexed tapes, ensure that the data class selects the same media type and recording technology for the original and the alternate copy. Not doing so can result in failure when the duplex tape is mounted for output, or when using the alternate copy after a tape replace. If different media or machine types are needed for the original and alternate tapes, see APARs OW52309, OA04821, and OA11603 for more information.

---

## Allowing DFSMSHsm to use the 3590-1 generic unit when it contains mixed track technology drives

You might encounter a situation in which you need to use the 3590-1 generic unit when it contains a mixture of 3590 devices that cannot share tapes. If so, you must use other means, such as SMS ACS routines, to keep these drives separate, and you can use this patch to disable the DFSMSHsm compatibility checking:

```
PATCH .MCVT.+3D5 BITS(.1.....)
```

You can use this patch to re-enable the DFSMSHsm compatibility checking:

```
PATCH .MCVT.+3D5 BITS(.0.....)
```

By default, checking is enabled for non-SMS tape allocations.

A non-SMS tape allocation for a generic unit 3590-1 containing mixed track technologies causes DFSMS to issue message ARC0030I. Here, DFSMSHsm allows the allocation to continue, but a tape/tape unit mismatch can result in an OPEN failure.

DFSMSHsm does not issue message ARC0030I for a mix of 3592-1, 3592-2 and 3592-2E tape units.



---

## Recovering overwritten encrypted tapes

Recovery of overwritten encrypted tape volumes might not be possible; the tape recovery process described in the topic "Case 6: Overwritten Migration Tape" of *z/OS DFSMSdfp Storage Administration* does not work for an encrypted tape.

---

## DFSMSHsm tips

See "DFSMSHsm tips" on page 313 for some tips that you might find helpful when using DFSMSHsm with the encryption-capable TS1120 tape drive.



---

## Chapter 34. DFSMSdss considerations for the encryption-capable TS1120 tape drive

DFSMSdss, a z/OS functional component, allows you to copy, move, dump, and restore data sets and volumes. DFSMSdss is the primary data mover of DFSMS/MVS.

This topic describes considerations for using DFSMSdss with the encryption-capable TS1120 tape drive, as follows:

- “Planning to use hardware encryption for dump tapes”
- “DFSMSdss handling of dump encryption requests” on page 236
- “DFSMSdss Stand Alone Restore program” on page 237
- “Updates to the Dump Volume Output Notification Exit (Exit 26)” on page 237.

---

### Planning to use hardware encryption for dump tapes

Using encryption-capable TS1120 tape drives does not require changes to your installation's DFSMSdss jobs. It does, however, require changes to your installation's data classes and DFSMShsm dump classes, as described previously in this information. These considerations are briefly summarized here for the awareness of DFSMSdss administrators.

System volumes such as SYSRES should not be dumped to an encrypted tape data set. Because the DFSMSdss Stand Alone Restore program does not support restoring data from encrypted tape volumes, any encrypted system volume will not be able to be restored using the DFSMSdss Stand Alone Restore program.

### Reviewing changes to SMS data classes

Using an encryption-capable TS1120 tape drive requires changes to your SMS data class definitions, as described in Chapter 33, “DFSMShsm considerations for the encryption-capable TS1120 tape drive,” on page 227.

For tapes that require software (or host-based) encryption, ensure that your dump-requesting jobs use only tape drives that are not enabled for hardware encryption. To do so, check the data classes of the output ddnames to ensure that the jobs do not specify a data class that requests encryption from the encryption-capable tape drives.

### Reviewing changes to DFSMShsm dump classes

If your DFSMShsm dump classes are currently defined to use host-based encryption (and possibly host-based compression before encryption), it is recommended that you remove the host-based encryption requests from any dump classes for which you plan to use hardware encryption. These steps are described in Chapter 33, “DFSMShsm considerations for the encryption-capable TS1120 tape drive,” on page 227.

Over time, as you migrate your DFSMShsm dump classes to use hardware encryption, you might still have dump classes that are defined to use host-based encryption, while their associated data classes are defined to use hardware encryption. Here, DFSMSdss ignores requests for host-based encryption for tape

volumes and, instead, uses hardware encryption. This processing allows you to complete the migration to hardware encryption without having to modify your DFSMSdss jobs.

If you no longer require host-based encryption for any of your tape volumes, remove the host-based encryption requests from all of your DFSMSShsm dump classes. Thereafter, your jobs can write to a mixture of encrypting tape devices and non-encrypting tape devices without incurring informational messages. This setup allows you to encrypt tapes that are to be sent off-site, while retaining unencrypted tapes on-site for disaster recovery purposes.

## DFSMSdss handling of dump encryption requests

With this support, hardware encryption joins software (or host-based) encryption as a means of encrypting your installation's tape volumes. Because DFSMSdss avoids performing double encryption of tape data, you must determine which type of encryption, if any, is to be used for your tape volumes. DFSMSdss prevents you from combining both types of encryption to perform double encryption of tape volumes.

Table 37 shows how DFSMSdss handles potential double encryption requests, specified through the DFSMSdss DUMP command.

*Table 37. DFSMSdss handling of dump encryption requests*

Dump encryption request	DFSMSdss action
Your DUMP command specifies host-based encryption (through the RSA or KEYPASSWORD keywords), and all of the available tape drives are encryption-capable tape drives. Your request might also specify host-based compression (through the HWCOMPRESS keyword).	<ul style="list-style-type: none"> <li>DFSMSdss issues informational message ADR518I to indicate that hardware encryption was used instead of host-based encryption</li> <li>DFSMSdss ignores the compression request, if any.</li> </ul>
Your DUMP command specifies host-based encryption and one or more of the available tape drives are not enabled for hardware encryption. Your request might also specify host-based compression.	<ul style="list-style-type: none"> <li>DFSMSdss issues error message ADR519E to indicate that one or more of the available tape drives cannot perform hardware encryption. To avoid performing double encryption of data, DFSMSdss uses only encryption-capable tape drives. DFSMSdss issues error message ADR324E to list the unused output devices.</li> <li>DFSMSdss ignores the compression request, if any.</li> <li>DFSMSdss continues processing the DUMP request as long as there are usable tape drives. On completion, DFSMSdss ends the task with return code 8.</li> </ul>
Your DUMP command does not specify host-based encryption and all of the available tape drives are encryption-capable tape drives. Your request might also specify host-based compression.	<ul style="list-style-type: none"> <li>Encryption-capable tape drives perform encryption</li> <li>DFSMSdss performs host-based compression, if requested.</li> </ul>

Table 37. DFSMSDss handling of dump encryption requests (continued)

Dump encryption request	DFSMSDss action
Your DUMP command does not specify host-based encryption and one or more of the available tape drives are not enabled for hardware encryption. Your request might also specify host-based compression.	<ul style="list-style-type: none"> <li>DUMP requests for encryption-capable tape drives are encrypted by the tape drive hardware</li> <li>DUMP requests for non-encrypting tape drives are processed without encryption of any type</li> <li>DFSMSDss performs host-based compression, if requested.</li> </ul>

## If double encryption is required

In the unlikely event that your installation requires double encryption for a dump data set, you can use this procedure:

1. Request host-based encryption for the data set and write it to a non-encrypting output device
2. Use the DFSMSDss COPYDUMP command to copy the dump data set to an encrypting tape device.

To restore the double-encrypted dump data set, use the DFSMSDss RESTORE command. The encryption capable tape drive decrypts the dump data set and then DFSMSDss performs host-based decryption for the data set.

---

## DFSMSDss Stand Alone Restore program

You cannot use the DFSMSDss Stand Alone Restore program with an encrypted tape. If you attempt to do so, DFSMSDss issues message ADRY513I to indicate that the dump data set resides on an encrypted tape and thus, cannot be read with the Stand Alone Restore program. DFSMSDss also issues message ADRY509D to prompt the operator to continue or end the function.

Similarly, you cannot use the DFSMSDss BUILDSA command to build a stand-alone image on an encrypted tape. If encryption is to be used in the encryption-capable TS1120 tape drive, DFSMSDss fails your request with message ADR992E.

---

## Updates to the Dump Volume Output Notification Exit (Exit 26)

If an application requests host-based encryption through the DFSMSDss application programming interface (API), and DFSMSDss overrides the encryption request, DFSMSDss uses the Volume Output Notification Exit (Exit 26) to notify the caller. To indicate that the output tape volume used hardware encryption, DFSMSDss sets the EI26TWHE bit to one in the ADREID0 mapping.

If applicable, review your Exit 26 routine for updates to use the EI26TWHE bit. Table 38 shows the ADREID0 mapping.

Table 38. ADREID0 mapping

Offsets		Type	Len	Name (Dim)	Description
Dec	Hex				
0	(0)	STRUCTURE	128	EIREC26	

Table 38. ADREID0 mapping (continued)

Offsets		Type	Len	Name (Dim)	Description
Dec	Hex				
0	(0)	BITSTRING	4	EI26TYPE	EXIT TYPE
		1... ....		EI26VOL	OUTPUT VOLUME NOTIFICATION
		.1.. ....		EI26TERM	OUTPUT VOLUME TERMINATED
		..1. ....		EI26R0CE	BWO R0 COUNT ERROR
		...1 ...		EI26VCLO	OUTPUT VOLUME CLOSE - ONLY FOR DASD OUTPUTS DURING LOGICAL DUMP OPERATIONS
		.... 1..		EI26TWHE	WHEN SET TO 1, THE OUTPUT TAPE VOLUME WILL USE HARDWARE ENCRYPTION.
		.... .xxx		*	UNUSED
0	(0)	BITSTRING	3	*	RESERVED FOR EXPANSION
4	(4)	CHARACTER	64	EI26DSN	DSNAME IF EI26ROCE = '1'B
68	(44)	UNSIGNED	1	EI26DSNL	LENGTH OF DSNAME
69	(45)	UNSIGNED	3	*	RESERVED FOR ALIGNMENT
72	(48)	CHARACTER	8	EI26DDN	OUTPUT DDNAME IF EI26VOL, EI26TERM, OR EI26VCLO SET
80	(50)	CHARACTER	6	EI26VSER	VOLSER - PRESENT IF EI26VOL, EI26TERM, EI26VCLO SET
86	(56)	CHARACTER	2	*	RESERVED FOR ALIGNMENT
88	(58)	UNSIGNED	4	EI26VTRC	RETURN FOR VOLUME TERM AND VOLUME CLOSE
92	(5C)	ADDRESS	36	*	RESERVED FOR EXPANSION

---

## Chapter 35. DFSMSrmm modifications for encryption-capable TS1120 tape drive

DFSMSrmm is a feature of z/OS. It manages all tape media, such as cartridge system tapes and 3420 reels, and other removable media that you define to it.

This topic describes the updates to these DFSMSrmm TSO subcommands:

- ADDVOLUME
- CHANGEVOLUME
- SEARCHVOLUME

It also lists the changed REXX variables of the TSO subcommand, API structured field introducers, and mapping macros fields.

### Related reading:

- See *z/OS DFSMSrmm Managing and Using Removable Media* for the complete syntax of the DFSMSrmm ADDVOLUME subcommand, the DFSMSrmm CHANGEVOLUME subcommand, the DFSMSrmm SEARCHVOLUME subcommand, DFSMSrmm return codes and reason codes, and REXX variables.
- See *z/OS DFSMSrmm Application Programming Interface* for further information about the DFSMSrmm API.
- See *z/OS DFSMSrmm Implementation and Customization Guide* and *z/OS DFSMSrmm Reporting* for additional information about DFSMSrmm mapping macros.

---

## ADDVOLUME

The ADDVOLUME TSO subcommand adds volumes to the DFSMSrmm control data set. This diagram shows the syntax of the MEDIATYPE operand, the RECORDINGFORMAT operand, the KEYLABEL1 and KEYENCODE1 operands, and the KEYLABEL2 and KEYENCODE2 operands for the ADDVOLUME TSO subcommand.

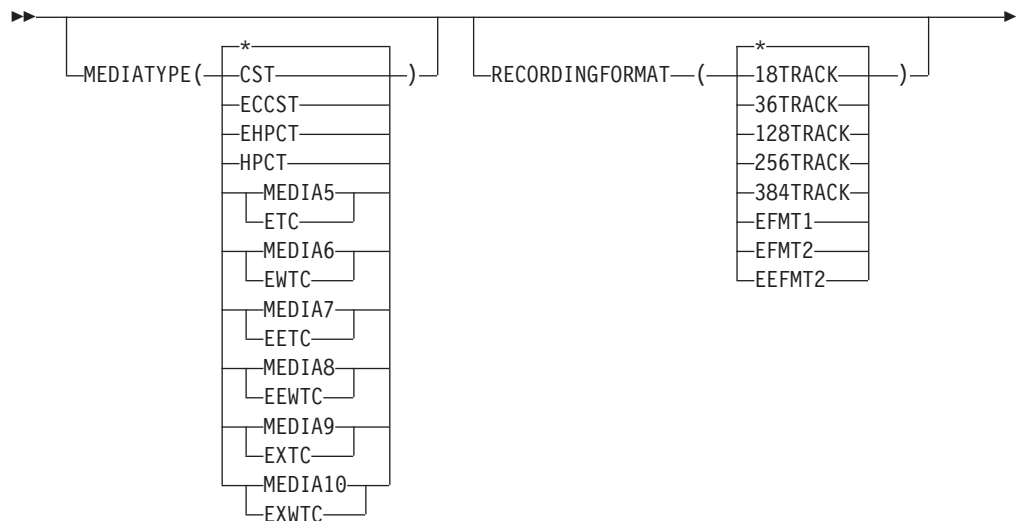

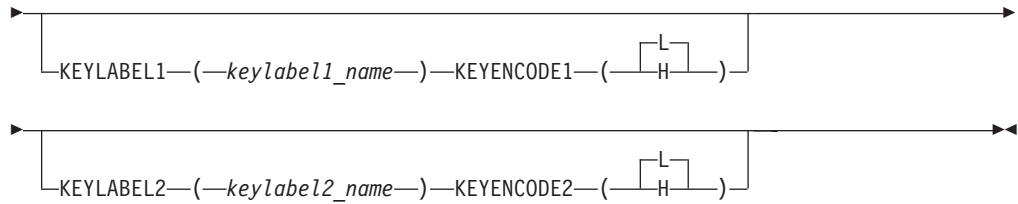

**KEYLABEL1**(*keylabel1\_name*)

Specifies the key encryption key label number 1 for a non-scratch volume that is encrypted. A key label is 1-to-64 characters with blanks padding the field on the right. A key label contains alphanumeric, national, or special characters with some additional characters also allowed. Enclose it in single quotation marks if it contains any blanks or special characters.

When a volume is rewritten in a non-encryption format, DFSMSrmm does not clear the encryption key label related fields. Instead, the fields continue to be displayed until the volume is reused from scratch, or a release action causes them to be cleared.

When you specify this optional operand, you can also specify a value for the key encoding mechanism using the KEYENCODE1 operand.

**KEYLABEL2**(*keylabel2\_name*)

Specifies the key encryption key label number 2 for a non-scratch volume that is encrypted. A key label is 1-to-64 characters with blanks padding the field on the right. A key label contains alphanumeric, national, or special characters with some additional characters also allowed. Enclose it in single quotation marks if it contains any blanks or special characters.

When a volume is rewritten in a non-encryption format, DFSMSrmm does not clear the encryption key label related fields. Instead, the fields continue to be displayed until the volume is reused from scratch, or a release action causes them to be cleared.

When you specify this optional operand, you can also specify a value for the key encoding mechanism using the KEYENCODE2 operand.

**KEYENCODE1**

Specifies the encoding mechanism used for KEYLABEL1.

- L** Label
- H** Public key hash

The default value is L.

**KEYENCODE2**

Specifies the encoding mechanism used for KEYLABEL2.

- L** Label
- H** Public key hash

The default value is L.

To use the EFMT2 and the EEFMT2 recording technology, you must specify the MEDIATYPE(MEDIA5/ETC, MEDIA6/EWTC, MEDIA7/EETC, MEDIA8/EEWTC, MEDIA9/EXTC, or MEDIA10/EXWTC) operand of the ADDVOLUME TSO subcommand.



## CHANGEVOLUME

The CHANGEVOLUME TSO subcommand updates details for a volume defined to DFSMSrmm. This diagram shows the syntax of the MEDIATYPE operand, the RECORDINGFORMAT operand, the KEYLABEL1/NOKEYLABEL1 and KEYENCOD1 operands, and the KEYLABEL2/NOKEYLABEL2 and KEYENCOD2 operands for the CHANGEVOLUME TSO subcommand.

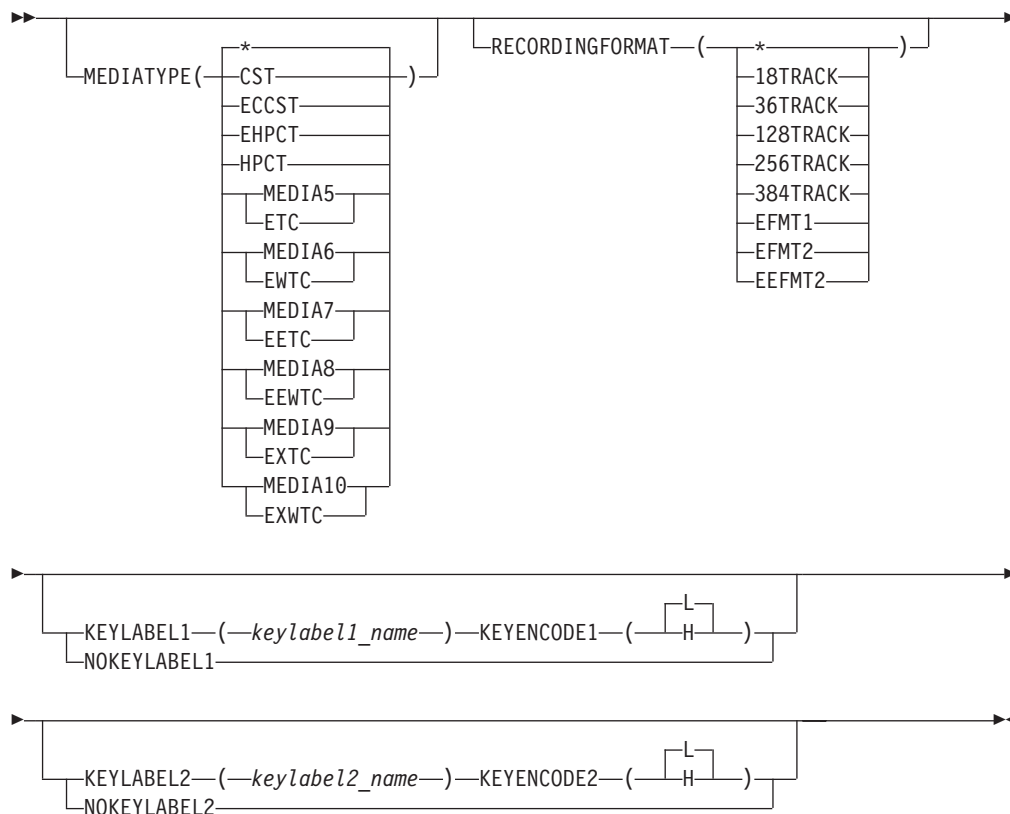

### KEYLABEL1(*keylabel1\_name*)

Specifies the key encryption key label number 1 for a non-scratch volume that is encrypted. A key label is 1-to-64 characters with blanks padding the field on the right. A key label contains alphanumeric, national, or special characters with some additional characters also allowed. Enclose it in single quotation marks if it contains any blanks or special characters.

When a volume is rewritten in a non-encryption format, DFSMSrmm does not clear the encryption key label related fields. Instead, the fields continue to be displayed until the volume is reused from scratch, or a release action causes them to be cleared.

When you specify this optional operand, you can also specify a value for the key encoding mechanism using the KEYENCOD1 operand.

KEYLABEL1 is mutually exclusive with NOKEYLABEL1.

### KEYLABEL2(*keylabel2\_name*)

Specifies the key encryption key label number 2 for a non-scratch volume that is encrypted. A key label is 1-to-64 characters with blanks padding the field on the right. A key label contains alphanumeric, national, or special characters with some additional characters also allowed. Enclose it in single quotation marks if it contains any blanks or special characters.

When a volume is rewritten in a non-encryption format, DFSMSrmm does not clear the encryption key label related fields. Instead, the fields continue to be displayed until the volume is reused from scratch, or a release action causes them to be cleared.

When you specify this optional operand, you can also specify a value for the key encoding mechanism using the KEYENCODE2 operand.

KEYLABEL2 is mutually exclusive with NOKEYLABEL2.

**KEYENCODE1**

Specifies the encoding mechanism used for KEYLABEL1.

- L** Label
- H** Public key hash

The default value is L.

**KEYENCODE2**

Specifies the encoding mechanism used for KEYLABEL2.

- L** Label
- H** Public key hash

The default value is L.

**NOKEYLABEL1**

Specify the NOKEYLABEL1 operand to clear an existing key encryption key label number 1 and encoding mechanism.

NOKEYLABEL1 is mutually exclusive with KEYLABEL1.

**NOKEYLABEL2**

Specify the NOKEYLABEL2 operand to clear an existing key encryption key label number 2 and encoding mechanism.

NOKEYLABEL2 is mutually exclusive with KEYLABEL2.

To use the EFMT2 and the EEFMT2 recording technology, you must specify the MEDIATYPE(MEDIA5/ETC, MEDIA6/EWTC, MEDIA7/EETC, MEDIA8/EEWTC, MEDIA9/EXTC, or MEDIA10/EXWTC) operand of the CHANGEVOLUME TSO subcommand.

---

## SEARCHVOLUME

You can use the SEARCHVOLUME TSO subcommand to obtain a list of volumes that match selection criteria that you specify. Specify EEFMT2 to limit your search to volumes that are written in the EEFMT2 recording technology. You can also specify a particular media type, such as MEDIA9, to then further limit your search. This diagram shows the syntax of the MEDIATYPE operand and the RECORDINGFORMAT operand for the SEARCHVOLUME TSO subcommand.

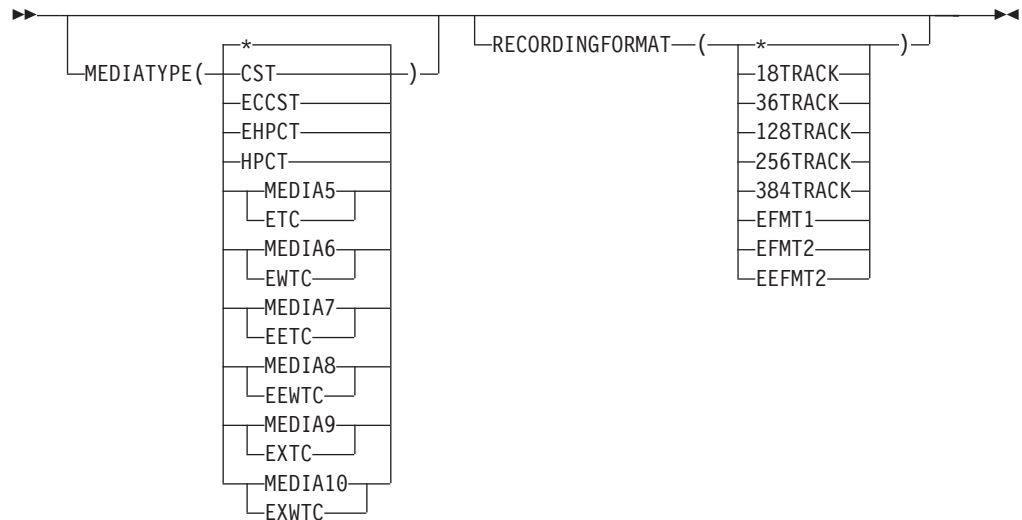

## LISTVOLUME

You can use the LISTVOLUME TSO subcommand to display information that is recorded by DFSMSrmm for a single volume. You must specify a volume serial number.

To request all the information recorded by DFSMSrmm for the encrypted volume with serial number JJC024, issue the command:

```
RMM LISTVOLUME JJC024 ALL
```

DFSMSrmm displays information such as that shown:

```

Volume information:
Volume = JJC024 VOL1 = Rack = JJC024 Owner = RMMUSER
Type = PHYSICAL Stacked count = 0 Jobname = D016216J
Worldwide ID =
Creation: Date = 08/28/2006 Time = 04:49:14 System ID = W98MVS2
Assign: Date = Time = System ID = W98MVS2
Expiration date = 09/02/2006 Original =
Retention date = Set retained = NO
Data set name = RMMUSER.TEST.CBR
Volume status:
Status = USER Availability = Label = SL
Current label version = Required label version =
Media information:
Density = IDRC Type = EETC Format = EEFMT2 Compaction = YES
Special attributes = NONE Vendor =
Encryption Key Labels: Method:
1=wccl LABEL
2=wc2 LABEL
Action on release:
Scratch immediate = N Expiry date ignore = N
Scratch = Y Replace = N Return = N Init = N Erase = N Notify = N
Actions pending:
Scratch = N Replace = N Return = N Init = N Erase = N Notify = N
Storage group =
Loan location = Account = T,H,IOM,,,SYSPROG
Description =
Security class = Description =
Access information:
Owner access = ALTER Volume access = NONE Last change = *OCE
VM use = N MVS use = Y
Access list:

```

```

Statistics:
Number of data sets = 2      Data set recording= ON
Volume usage(Kb)= 2        Use count      = 3
Volume capacity = 59232    Percent full   = 0
Date last read  = 08/28/2006 Date last written = 08/28/2006
Drive last used = 0FA0     Write mount count = 2
Volume sequence = 1        Media name     = 3480
Previous volume =           Next volume    =
Product number =           Level          = V R M
Feature code   =

Error counts:
Temporary read = 0          Temporary write = 0
Permanent read = 0          Permanent write = 0
Store information:
Movement tracking date =           Intransit = N
In container      =           Move mode = AUTO
Location: Current Destination Old Required Home
Name              = ATL15393
Type              = AUTO
Bin number =
Media name =

```

---

## DFSMSrmm REXX variables

You can use the REXX variables to obtain volume information. The variables produced by the SEARCHVOLUME subcommand are stem variables.

*Table 39. Changed TSO subcommand REXX variables*

Variable Name	Subcommands	Contents	Format
EDG@MEDR	LV SV	Recording technology	One of *, 18TRK, 36TRK, 128TRK, 256TRK, 384TRK, EFMT1, EFMT2, and EEFMT2
EDG@KEL1	LV	Key encryption key label 1	1 to 64 characters
EDG@KEL2	LV	Key encryption key label 2	1 to 64 characters
EDG@KEM1	LV	Key encoding mechanism for key label 1	LABEL or HASH
EDG@KEM2	LV	Key encoding mechanism for key label 2	LABEL or HASH

---

## DFSMSrmm structured field introducers

The DFSMSrmm application programming interface (API) returns data as structured fields in an output buffer that you define. Structured fields consist of a structured field introducer (SFI) and the data. SFIs describe the type, length, and other characteristics of the data.

Table 40 on page 245 shows the structured field introducers that support encryption-capable TS1120 tape drive tape drives.

Table 40. Changed structured field introducers

Name	Number	Type	Length	Value	Subcommands
MEDR	X'857000'	Binary(8)	9	Media type: 0=NON-CARTRIDGE 1=18TRK 2=36TRK 3=128TRK 4=256TRK 5=384TRK 6=EFMT1 7=EFMT2 8=EEFMT2	LV, SV
KEL1	X'83F500'	Character (variable length)	72	Key encryption key label 1	LV, SV(e)
KEL2	X'83F505'	Character (variable length)	72	Key encryption key label 2	LV, SV(e)
KEM1	X'83F520'	Character (variable length)	13	Key encoding mechanism for key label 1: LABEL or HASH	LV, SV(e)
KEM2	X'83F525'	Character (variable length)	13	Key encoding mechanism for key label 2: LABEL or HASH	LV, SV(e)

## DFSMSrmm macros

Table 41 shows the changes made to DFSMSrmm mapping macros for encryption-capable TS1120 tape drive tape drives.

Table 41. DFSMSrmm mapping macro changes

Mapping macro	Function	Updates
EDGEXTSY	Maps the extract data set symbols used with DFSORT.	Recording technology values: EFMT1, EFMT2, EEFMT2.  Key encryption key label 1. Key encoding mechanism for key label 1: LABEL or HASH  Key encryption key label 2. Key encoding mechanism for key label 2: LABEL or HASH
EDGRVEXT	Maps the volume records in the DFSMSrmm extract data set.	Recording technology values: EFMT1, EFMT2, EEFMT2.  Key encryption key label 1. Key encoding mechanism for key label 1: LABEL or HASH  Key encryption key label 2. Key encoding mechanism for key label 2: LABEL or HASH
EDGRXEXT	Maps the extended data set records in the DFSMSrmm extract data set.	Recording technology values: EFMT1, EFMT2, EEFMT2.  Key encryption key label 1. Key encoding mechanism for key label 1: LABEL or HASH  Key encryption key label 2. Key encoding mechanism for key label 2: LABEL or HASH

Table 41. DFSMSrmm mapping macro changes (continued)

Mapping macro	Function	Updates
EDGSMFSY	Maps the SMF record symbols used with DFSORT.	Recording technology values: EFMT1, EFMT2, EEFMT2.  Key encryption key label 1. Key encoding mechanism for key label 1: L=LABEL H= HASH.  Key encryption key label 2. Key encoding mechanism for key label 2: L=LABEL H= HASH.
EDGSVREC	Maps the DFSMSrmm SMF volume records.	Recording technology values: EFMT1, EFMT2, EEFMT2.  Key encryption key label 1. Key encoding mechanism for key label 1: L=LABEL H= HASH.  Key encryption key label 2. Key encoding mechanism for key label 2: L=LABEL H= HASH.
EDGCLREC	Maps the DFSMSrmm conversion library record.	Recording technology values: EFMT1, EFMT2, EEFMT2.  Key encryption key label 1. Key encoding mechanism for key label 1: L=LABEL H= HASH.  Key encryption key label 2. Key encoding mechanism for key label 2: L=LABEL H= HASH.

---

## Chapter 36. EREP modifications for encryption-capable TS1120 tape drive

Environmental Recording, Editing, and Printing (EREP) program is a diagnostic application program that runs under MVS, VM, and VSE. It generates and prints reports from error recording data set (ERDS) records. With these reports, IBM service representatives can determine the existence, nature, and location of a problem.

EREP reports display the encryption-capable TS1120 tape drive as "3592-E05". For examples of EREP reports showing this model type, see Chapter 48, "EREP modifications for 3592 Model E05," on page 323.





---

## Chapter 37. JES3 modifications for encryption-capable TS1120 tape drive

JES3, a z/OS MVS subsystem, manages resources and work flow before and after jobs are processed. You can enable JES3 to allocate encryption-enabled 3592 Model E05 tape drives and tape volumes in an SMS-managed IBM tape library environment (automated or manual) for 3590 Model B emulation only. To do so, you need to specify at least one of these library device group (LDG) names in your JES3plex. An LDG is a predefined set of tape subsystems within a JES3plex.

### **LDLsssss**

Includes any encryption-enabled 3592 Model E05 devices with the library indicated by serial number sssss.

### **LDGdddd**

Includes any encryption-enabled 3592 Model E05 devices (dddd=359L) in any library in the JES3plex.

See *z/OS JES3 Initialization and Tuning Reference* for additional information on LDGs, JES3, and JES3plex.



---

## Chapter 38. OAM modifications for encryption-capable TS1120 tape drive

The Object Access Method (OAM) is a component of DFSMSdftp. OAM uses the concepts of system-managed storage, introduced by SMS, to manage, maintain, and verify tape volumes and tape libraries within a tape storage environment. You can also use OAM's object support to manage objects on DASD, tape, and optical volumes.

### Related reading:

- See *z/OS DFSMS OAM Planning, Installation, and Storage Administration Guide for Tape Libraries* for additional information about using OAM to manage tape volumes and tape libraries.
- See *z/OS DFSMS OAM Planning, Installation, and Storage Administration Guide for Object Support* for additional information about using OAM to manage the data on tape volumes.
- See *z/OS MVS System Messages, Vol 4 (CBD-DMO)* for explanations and appropriate actions for CBRxxxx messages.

---

### OAM library support

OAM uses the concepts of system-managed storage, introduced by SMS, to manage, maintain, and verify tape volumes and tape libraries within a tape storage environment. This topic describes the OAM library support functions that have been changed for use with the encryption-capable TS1120 tape drives. The enhancements include support for a new recording format EEFMT2. The EEFMT2 recording technology is supported starting with z/OS V1R4. Support for MEDIA9 and MEDIA10 media types, added with the base 3592 Model E05 support, begins with z/OS V1R5; therefore, any mention of MEDIA9 or MEDIA10 media types with this support applies to z/OS V1R5 and above.

These steps should be considered when planning to use the new 3592-2E drives:

1. Define the new devices using HCD.
2. Modify your ACS routines to select tape storage groups and libraries with 3592 Model E05 (encryption capable) devices.
3. Add, as appropriate, data classes to use EEFMT2 on the new 3592-2E drives.
4. Specify, as appropriate, the key labels and encoding mechanism for each label.
5. Contact your tape management system vendor to obtain their support and any modified installation exits.

### LCS external services changes

LCS External Services supports the applicable encryption-capable TS1120 tape drive media types, MEDIA5, MEDIA6, MEDIA7, MEDIA8, MEDIA9, and MEDIA10, and the recording technologies, EFMT1, EFMT2, and EEFMT2, for these functions:

- Change use attribute
- Query volume residence
- Test volume eligibility
- Eject a volume

- Manual cartridge entry

**Note:**

- The MEDIA5, MEDIA6, MEDIA7, and MEDIA8 media types are valid with the EFMT1, EFMT2, and EEFMT2 recording technologies.
- The MEDIA9 and MEDIA10 media types are valid only with the EFMT2 and EEFMT2 recording technologies.
- In general, in an environment sharing the TCDB at different software levels, if a lower-level system without appropriate support attempts to perform one of the CBRXLCS functions using a volume that has EEFMT2 recording technology, the request fails with existing return code LCSFAIL (12) and existing reason code LCSFNSUP (310).
- Coexistence support is provided at z/OS V1R4 and above to enable, during job processing, a scratch volume that is previously written with an up-level recording format to be used by a lower-level system that does not recognize the recording format. Because there is only one scratch pool per media type and that scratch pool can be used across systems at different levels of support, this support ignores the scratch volume's previous recording format and enables the scratch volume to be used on the lower-level system.

## OAM installation exits changes

These installation exits support EEFMT2 recording technology:

- Change use attribute (CBRUXCUA) installation exit: Tape recording technology fields have been updated with EEFMT2.
- Cartridge entry (CBRUXENT) installation exit: Tape recording technology fields have been updated with EEFMT2.
- Cartridge eject (CBRUXEJC) installation exit: Tape recording technology fields have been updated with EEFMT2.
- Volume not in library (CBRUXVNL) installation exit: Tape recording technology fields have been updated with EEFMT2. For additional information regarding this exit, refer to “Volume not in library installation exit enhancement” on page 332.

## Operator command support changes

Volumes with EEFMT2 recording technology are only displayed on systems with full encryption-capable TS1120 tape drive support installed.

These operator tasks have been changed in support of the encryption-capable TS1120 tape drive.

- The DISPLAY SMS,VOLUME command displays the new EEFMT2 recording technology.
- The LIBRARY DISPDRV command displays 3592-2E for the encryption-capable TS1120 tape drive in the output display for CBR1220I (Tape drive status).
- The LIBRARY SETCL command allows MEDIA5, MEDIA6, MEDIA7, MEDIA8, MEDIA9, and MEDIA10 to be set for an encryption-capable TS1120 tape drive that supports a cartridge loader.

## Mount processing change

Since an encryption-capable TS1120 tape drive is able to read and write in the three 3592 recording formats (EFMT1, EFMT2, and EEFMT2), for a DISP=OLD request (or DISP=MOD treated as OLD), for an EFMT1 recorded volume, preference is given to the 3592 Model J1A, then to the base 3592 Model E05, and then to the

encryption-capable TS1120 tape drive. For an EFMT2 request, preference is given to the 3592 Model E05 and then to the encryption capable 3592 Model E05. For a DISP=NEW request, an encryption-capable TS1120 tape drive is considered eligible for an EFMT1 and an EFMT2 request, as well as for the new EEFMT2 request. If a media type is not specified, for an EEFMT2 scratch request, the preference is MEDIA9 followed by MEDIA5 and then MEDIA7, enabling the higher capacity cartridges to be selected first.

## OAM macro changes

Table 42 describes changes to OAM mapping macros and installation exit parameter lists in support of encryption-capable TS1120 tape drives.

Table 42. OAM mapping macro changes

The macro	that maps	has these changes.
CBRTDSI	the tape device selection information (TDSI)	TDSEEFMT2 EQU 8 READ/WRITE ON ENTERPRISE * ENCRYPTED FORMAT 2 (EEFMT2) DEVICE
CBRTVI	the tape volume information	TVIEEFMT2 EQU 8 READ/WRITE ON ENTERPRISE ENCRYPTED FORMAT 2 (EEFMT2) DEVICE TVIREVV EQU 11 REVISION LEVEL
CBRUXCPL	the change use attribute installation exit parameter list	UXCEEFMT2 EQU 8 READ/WRITE ON ENTERPRISE ENCRYPTED FORMAT 2 (EEFMT2) DEVICE
CBRUXEPL	the cartridge entry installation exit parameter list	UXEEEFMT2 EQU 8 READ/WRITE ON ENTERPRISE ENCRYPTED FORMAT 2 (EEFMT2) DEVICE
CBRUXJPL	the cartridge eject installation exit parameter list	UXJEEFMT2 EQU 8 READ/WRITE ON ENTERPRISE ENCRYPTED FORMAT 2 (EEFMT2) DEVICE
CBRUXNPL	the volume not in library installation exit parameter list	UXNEEFMT2 EQU 8 READ/WRITE ON ENTERPRISE ENCRYPTED FORMAT 2 (EEFMT2) DEVICE .

## Cartridge entry processing

When a volume is entered into an IBM automated or manual tape library, the cartridge entry installation exit (CBRUXENT) is invoked to approve or deny an enter request, and to set or verify the recording technology to be associated with a volume.

If a volume TCDB record does not exist for the entry of a private MEDIA5, MEDIA6, MEDIA7, or MEDIA8 volume and there is no applicable recording technology being provided by the library's entry default data class, EFMT1 is passed to the exit; UNKNOWN might be passed for a scratch volume. If the exit returns with a recording technology for a MEDIA5, MEDIA6, MEDIA7, or MEDIA8 volume, and it is not EFMT1, EFMT2, or EEFMT2 (UNKNOWN is also allowed for a scratch volume), the specification is considered invalid, and the exit is disabled.

If a volume TCDB record does not exist for the entry of a private MEDIA9 or MEDIA10 volume, and there is no applicable recording technology being provided by the library's entry default data class, EFMT2 is passed to the exit; UNKNOWN might be passed for a scratch volume. If the exit returns with a recording

technology for a MEDIA9 or MEDIA10 volume and it is not EFMT2 or EEFMT2 (UNKNOWN is also allowed for a scratch volume), the specification is considered invalid and the exit is disabled.

If a TCDB volume record exists and the volume's recording technology or media type is not supported on the system processing the volume, in an ATLDS, the volume is left in the library manager insert category to be processed by a system with appropriate support. The cartridge entry installation exit (CBRUXENT) is passed via register 1, the pointer to a parameter list mapped by CBRUXEPL.

If CBRXLCS FUNC=MCE is used to enter a volume into an MTL and its existing TCDB record has EEFMT2 recording technology or an unsupported media type (MEDIA9/MEDIA10, V1R4 system) and the software does not support the recording technology or the media type, the request fails with existing return code LCSFAIL (12) and existing reason code LCSFNSUP (310). If the CBRUXENT exit returns a unsupported recording technology or media type, the entry of the volume also fails.

---

## OAM object tape support

In a stand-alone environment, the SETOAM TAPEUNITNAME parameter in the CBROAMxx member of PARMLIB can be specified using an esoteric that contains encryption-capable TS1120 (3592-2E) tape drives. In the stand-alone environment, 3592 Model J, 3592 Model E05 (not encryption capable), and 3592 Model E05 (encryption capable) drives need to be segregated in their own unique esoteric in order to prevent allocating a 3592-J or 3592-2 drive for a volume written with EEFMT2 recording technology, because EEFMT2 is only compatible with 3592-2E drives. You can use the SETOAM DATACLASS parameter to specify EEFMT2 recording format to encrypt data, or specify non-encryption formats (EFMT1 or EFMT2). If no recording technology is specified, the default recording format for the TS1120 drives is EFMT2 when writing from load point. In an IBM tape library environment, the SETOAM DATACLASS parameter at the storage group (or global level) can be used to specify a desired recording technology and ensure allocating an appropriate drive.

The ERDS Physical ID (EPI) value for the 3592-2E drive is a hex '13' and is stored in the DB2 TAPEVOL table of the OAM Optical Configuration Database (OCDB) for a volume written in EFMT1, EFMT2, or EEFMT2 by a 3592-2E drive, and displayed, as appropriate, in the volume display. For the encryption-capable TS1120 tape drive (always in 3590 emulation mode), OAM derives the media type and capacity from the control unit. If EEFMT2 recording technology is used to write on the volume, the MEDIA5 and MEDIA6 capacity is 488281088 KB. The MEDIA7 and MEDIA8 economy capacity is 97655808 KB. The MEDIA9 and MEDIA10 extended capacity is 700 GB.

---

## Object tape migration considerations

If you choose to encrypt your object data, any partially filled non-encrypted tape volumes associated with an object storage group that you want to encrypt, should be marked full and not writable, so they are not selected. This is important because at the volume level all of the data on the tape is either encrypted or non-encrypted, and a mix of the two cannot reside on the same tape.

In the past, when migrating to a new drive model with a new recording technology using media types that could also be used at a lower-level recording technology, you marked your partially filled volumes as full or not writable and

new write requests were done at the new recording technology. When migrating from 3592-J or 3592-2 drives to 3592-2E drives, volumes written with EFMT1 or EFMT2 recording technology and not filled to capacity do not need to be marked as full or not writable. Data can be extended using the EFMT1 or EFMT2 recording technology on the encryption-capable TS1120 tape drive.

These items should be considered when planning to use 3592-2E drives:

If the 3592-2E devices are in an IBM tape library:

1. Follow the steps listed in “OAM library support” on page 251 for OAM Library Support.
2. Add new data classes, specifying EEFMT2 recording technology.
3. Review ACS routines for STORE, or CTRANS, or both environments for any changes that may be necessary to ensure proper class assignment.

If the 3592 Model E05 (encryption capable) devices are not in an IBM tape library, use device esoterics for STORAGEEGROUP statements in the CBROAMxx member of PARMLIB for the Object storage groups that are to use the new devices. It is important to segregate in an esoteric or generic the 3592 Model J devices and 3592 Model E05 (not encryption capable) from 3592 Model E05 (encryption capable) devices to prevent allocating an inappropriate drive for a volume written in EEFMT2 recording technology. Add new TAPEUNITNAME with the new device esoteric to the STORAGEEGROUP statements in the CBROAMxx PARMLIB member for object storage groups or object backup storage groups that use the new devices.

---

## Object tape volume management support

The encryption-capable TS1120 tape drive supports the existing 3592 media types (MEDIA5, MEDIA6, MEDIA7, MEDIA8, MEDIA9, and MEDIA10), including special handling of WORM (MEDIA6, MEDIA8, and MEDIA10) tape volumes that have expired. You cannot recycle WORM tape volumes because they cannot be written from load point.





---

## Chapter 39. MVS IOS support for TS1120 tape drive

This topic describes changes to the IOS parmlib member and the MVS system commands to enable in-band key management for the encryption-capable TS1120 tape drive.

### Related reading:

- For information about the IECIOSxx parmlib member, see *z/OS MVS Initialization and Tuning Reference*
- For information about MVS commands, see *z/OS MVS System Commands*

---

### Changes to MVS parmlib members

A new parameter, EKM, is added to the IECIOSxx parmlib member in support of the encryption-capable TS1120 tape drive. With the EKM parameter, you can specify options for the Encryption Key Manager on your system. Refer to *z/OS MVS Initialization and Tuning Reference* for information on the IECIOSxx parmlib member.

---

### Changes to MVS system commands

These MVS operator commands are updated in support of the encryption-capable TS1120 tape drive:

- DISPLAY IOS,EKM command
  - Displays the host names for the primary and secondary Encryption Key Manager (EKM).
  - Displays the maximum number of TCP/IP connections to the EKM, and the maximum number of permanent connections that can exist during EKM processing.
  - Verifies the EKM connectivity.
- SETIOS EKM command
  - Specifies the host names for the primary and secondary encryption key manager.
  - Specifies the maximum number of TCP/IP connections to the EKM, and the maximum number of permanent connections that can exist during EKM processing.

For more information about the DISPLAY IOS or SETIOS commands, see *z/OS MVS System Commands*.

---

### Other administration tasks in support of MVS in-band tape encryption

In-band tape encryption requires that the IOS address space has security permissions for a USS segment. The USS segment is only for TCP/IP connectivity; UID(0) or super user ability is not required. Depending on the security product running on your system, take one of these actions to obtain the security permission:

- In RACF, issue:  
`ADDUSER IOSAS OMVS(UID(xxxx) HOME('/'))`

where *xxxx* is a unique user id

- In CA-Top Secret Security for z/OS or eTrust, issue:  
TSO TSS ADD( IOSAS) UID( *xxxx*) HOME( '/' )

where *xxxx* is a unique user id.

- In CA-ACF2 Security for z/OS authorization, issue:  
TSO ACF INSERT IOSAS NAME( IOSAS ID) UID( *xxxx*) HOME( /)

where *xxxx* is a unique user id.

If a USS segment is not available at the time of tape encryption, this message is issued:

```
IOS628E ENCRYPTION ON DEVICE dddd HAS FAILED DUE TO OMVS SEGMENT FAILURE
```

**Note:** After adding the USS segment for the IOS address space, an IPL is needed for the new IOSAS segment to take affect.

---

## IOS Proxy Retry Logic

When attempting to communicate with the primary Encryption Key Manager, the IOS proxy interface may retry several times before switching over to the secondary Encryption Key Manager. While these retries are occurring, the job may appear to have hung. Before cancelling the job, ensure that enough time is allowed because of these retry attempts that may be occurring on the primary Encryption Key Manager and also the secondary Encryption Key Manager. Typically, each retry attempt may take around 3 minutes with two retry attempts on the primary Encryption Key Manager before the IOS proxy interface attempts to connect to the secondary Encryption Key Manager. Similar logic is then in place with the secondary Encryption Key Manager. Once the IOS proxy interface has switched to the secondary Encryption Key Manager, it will always attempt to communicate with the primary Encryption Key Manager on subsequent communications. However, in this case, only one (shortened) attempt is made to communicate with the primary Encryption Key Manager before going back to the secondary Encryption Key Manager. If the IOS proxy interface cannot communicate with the primary Encryption Key Manager, even though the job may have been successful, message IOS627E is issued in the job log and in the system log alerting you to a potential problem with the primary Encryption Key Manager.

---

## **Part 4. 3592 Model E05 (also referred to as the TS1120)**



---

## Chapter 40. Introduction for 3592 Model E05

This topic describes the IBM System Storage Tape System 3592 Model E05 tape drives and the z/OS software support needed to use them.

---

### IBM System Storage Tape System 3592

The IBM System Storage Tape System 3592 provides high capacity, performance, and reliability, along with a wide range of host connectivity. Specifically, the IBM System Storage Tape System 3592 offers these features:

- Creates tapes for archive files.
- Backs up and restores systems in case of system or disk storage problems.
- Stores high-speed, high-capacity sequential application data sets.
- Stores temporary data sets.
- Satisfies off-site data storage for disaster recovery.
- Provides data interchange with other systems that use 3592 subsystems.
- Supports WORM (write once, read many) tape data cartridges whose data cannot be altered.

---

### 3592 Model E05 tape drive

The IBM System Storage Tape System 3592 Model E05 tape drive reduces data storage costs by increasing media capacity. The 3592 Model E05 reads and writes in the new recording format EFMT2 (enterprise format 2) as well as EFMT1 (enterprise format 1). EFMT2 provides almost double the capacity of EFMT1. The IBM System Storage Tape System 3592 uses these IBM System Storage Tape System family of tape media for a 3592 Model E05:

- MEDIA5 - The IBM TotalStorage Enterprise Tape Cartridge (MEDIA5) physical media. Provides an uncompressed capacity of 500 GB with EFMT2 (300 GB with EFMT1) and compressed capacity of 1500 GB with EFMT2 (900 GB with EFMT1) assuming a 3:1 compression ratio, depending on the type of data written.
- MEDIA6 - The IBM TotalStorage Enterprise WORM Tape Cartridge (MEDIA6) physical media. Provides an uncompressed capacity of 500 GB with EFMT2 (300 GB with EFMT1) and compressed capacity of 1500 GB with EFMT2 (900 GB with EFMT1) assuming a 3:1 compression ratio, depending on the type of data written.
- MEDIA7 - The IBM TotalStorage Enterprise Economy Tape Cartridge (MEDIA7) physical media. Provides an uncompressed capacity of 100 GB with EFMT2 (60 GB with EFMT1) and compressed capacity of 300 GB with EFMT2 (180 GB with EFMT1) assuming a 3:1 compression ratio, depending on the type of data written.
- MEDIA8 - The IBM TotalStorage Enterprise Economy WORM Tape Cartridge (MEDIA8) physical media. Provides an uncompressed capacity of 100 GB with EFMT2 (60 GB with EFMT1) and compressed capacity of 300 GB with EFMT2 (180 GB with EFMT1) assuming a 3:1 compression ratio, depending on the type of data written.
- MEDIA9 - The IBM TotalStorage Enterprise Extended Tape Cartridge (MEDIA9) physical media. MEDIA9 requires the EFMT2 recording format, and provides an uncompressed capacity of 700 GB and compressed capacity of 2100 GB assuming a 3:1 compression ratio, depending on the type of data written.

- MEDIA10 - The IBM TotalStorage Enterprise Extended WORM Tape Cartridge (MEDIA10) physical media. MEDIA10 requires the EFMT2 recording format, and provides an uncompressed capacity of 700 GB and compressed capacity of 2100 GB assuming a 3:1 compression ratio, depending on the type of data written.

You can use the 3592 Model E05 tape drive in the stand-alone environment or the tape library environment (automated or manual). Currently, the 3592 Model E05 tape drive does not have a cartridge loader.

Support for the 3592 Model E05 is provided at z/OS V1R4 or later releases, however support for MEDIA9 and MEDIA10 requires z/OS V1R5 or later releases.

Software support of the new media, MEDIA9 and MEDIA10, is available with the support of the 3592 Model E05, however the media itself will be available at a later GA.

The 3592 Model E05 tape drive offers these features:

- If no recording technology has been specified for MEDIA5, MEDIA6, MEDIA7, MEDIA8, MEDIA9, or MEDIA10, EFMT2 is the default recording technology.
- When writing from load point, the default recording technology of the 3592 Model E05 is EFMT2. If EFMT1 is needed for interchange purposes, it can be specified through data class. This applies to both the stand-alone and to the system-managed tape library environments.
- To enable the EFMT2 formatted cartridges to be relabelled/reused from load point on a 3592 Model J1A, a microcode update is required on the 3592 Model J1A.
- The 3592 Model E05 optionally provides performance scaling by using only the first 20 percent full capacity on a MEDIA5 or MEDIA9 cartridge. The default is to use the cartridge's full capacity. This performance scaling option is available on MEDIA5 and MEDIA9 tapes and is not available on MEDIA6, MEDIA7, MEDIA8, or MEDIA10 tape cartridge media.
- The 3592 Model E05 optionally provides performance segmentation. Performance segmentation divides the cartridge into a fast access segment and a slower access segment. The fast access segment will be filled first, after which the slower segment will be filled. This option is available on MEDIA5 and MEDIA9 tapes and is not available on MEDIA6, MEDIA7, MEDIA8, or MEDIA10 tape cartridge media. The performance segmentation option is mutually exclusive with the performance scaling option.
- The 3592 Model E05 emulates only 3590 Model B1x tape drives (all 3592 tape cartridge media supported in this emulation mode) in standalone and in a system-managed tape library environment (manual or automated).
- The 3592 Model E05 supports only the 3592 Model J70 tape controller, with either ESCON or FICON attachment.
- The 3592 Model E05 coexists with 3490E, 3590, and 3592 Model J1A devices in the 3494 automated tape library.
- The 3592 Model E05 coexists with 3592 Model J1A in the 3584 automated tape library.
- The 3592 Model E05 coexists with 3490, 3490E, 3590, and 3592 Model J1A devices in a manual tape library.

The 3592 Model E05 tape drive is always in emulation mode as a 3590 Model B1x device. The 3592 Model E05 cannot use the MEDIA3 or MEDIA4 cartridges used in 3590 tape drives.

The 3592 Model E05 also supports special modes that enable a 3592 Model E05 to behave as a 3592 Model J1A. When a 3592 Model E05 is attached to a J70 control unit that also has 3592 Model J1A devices, the 3592 Model E05 will appear to the host as a 3592 Model J1A, thus ensuring that all devices attached to the same control unit are homogeneous and have the same behaviors.

**Related reading:**

- See *IBM System Storage TS1120 Tape Drive and Controller Introduction and Planning Guide*, GA32-0555, for additional information.

---

## Write Once, Read Many (WORM)

The write-once, read-many (WORM) function of tape data storage is accomplished on the 3592 Model E05 by a combination of microcode controls in the drive, and a special WORM tape cartridge (MEDIA6, MEDIA8 or MEDIA10). All 3592 drives are capable of reading and writing WORM cartridges.

When the drive senses that a cartridge is a WORM cartridge, the microcode prohibits the changing or altering of user data already written on the tape. The microcode keeps track of the last appendable point on the tape by means of an overwrite-protection pointer stored in the cartridge memory (CM). Statistical Analysis and Reporting System (SARS) data can be written and updated on WORM tapes because the SARS data is not in the user area of the tape. Each WORM cartridge is identified using a world-wide unique cartridge identifier (WWCID), which is permanent and locked, providing another level of security for data that must be maintained. This permanent locked information is stored in both the cartridge CM and on the tape itself, and can also be associated with the unique barcode VOLSER.

**Note:** In some publications, the world-wide unique cartridge identifier (WWCID) may also be referred to as the world-wide identifier (WWID).

While overwriting of data on a WORM cartridge is not allowed, appending is permitted under certain conditions. These operations are allowed:

- Appending an additional labeled file following the final file on a tape volume. This overwrites the final tape mark of a final pair of tape marks followed by a header label group for the file to be appended. Appending is only permitted where the trailer label group begins with a record that starts with EOF rather than EOVS. EOVS indicates that a file has been extended to a different volume.
- Appending an additional unlabeled file following the final file on a tape volume. This overwrites the final tape mark of a final pair of tape marks followed by the user file to be appended.
- Appending additional records to the final labeled file on a tape volume. This overwrites the final trailer label group and the tape mark immediately prior to the final trailer label group followed by the final file's user data records. Appending is only permitted where the trailer label group begins with a record that starts with EOF rather than EOVS.
- Appending additional records to the final unlabeled file on a tape volume. This overwrites the final tape mark or pair of tape marks immediately following the last user data record of the unlabeled file.
- Relabeling a tape volume when only a header label group has been written and no user data records nor trailer label group has been written. This rewrites the header label group, including volume labels and remaining initial header label group records, where volume identification and other fields in the header label group may be changed. This is prohibited if the header label group was

followed by a trailer label group, user data records, or more than two tape marks because user data is never overwritten.

Header label groups and trailer label groups are recognized when all records within them conform to either IBM Standard or ANSI Standard label definitions. Any record with a prefix not recognized as conforming to these standards is assumed to be a user data record and causes overwriting of the entire label group to be prohibited. Double tape marks are assumed to occur only after the final recorded unlabeled file or the final label group on a tape. More than two adjacent tape marks indicate a null structure, such as a null user data file, between the first two of the multiple adjacent tape marks. For this reason, no more than two final tape marks are overwritten in any attempt to append.

In addition, the 3592 drive permits certain normal error recovery actions to succeed when writing to a volume that had been previously interrupted due to some equipment, connectivity, or power malfunction. In particular, in ESCON and FICON attachment environments, certain channel error recovery programs are supported via a mode of operation where the ESCON or FICON controller simulates the rewriting of records. The simulation of rewriting of records presents the appearance at the host of successful rewrites of logical records. The simulation succeeds only if the actual record already recorded on the medium precisely matches the record sent to the 3592 drive from the host.

---

## Performance scaling and segmentation for 3592

The 3592 Model E05 supports performance scaling and performance segmentation of media tape cartridges. These functions allow you to optimize performance for MEDIA5 and MEDIA9 cartridges; a cartridge can be defined for performance scaling or performance segmentation, but not both.

Performance scaling, also known as capacity scaling, is a function that allows you to contain data in a specified fraction of the tape, yielding faster locate and read times. Performance scaling for the 3592 Model E05 limits the data written to the first 20% (the optimally scaled performance capacity) of the cartridge. To select performance scaling for a cartridge, do these steps:

1. Define a data class that requests performance scaling.
2. Modify or create ACS routines to associate the tape output functions using performance scaling with a data class that requests performance scaling.

The 3592 Model E05 tape drive also divides the tape into longitudinal segments. Using this capability, it is possible to segment the tape into two segments, one as a fast access segment to be filled first, and the other as additional capacity to be filled after. If you decide to use the performance segmentation attribute, do these steps:

1. Define a data class that requests performance segmentation.
2. Modify or create ACS routines to associate the tape output functions using performance segmentation with a data class that requests performance segmentation.

Performance segmentation can also be used with the 3592 Model J1A with MEDIA5, as can performance scaling.

With the 3592 Model E05 and EFMT2, the MEDIA5 cartridge can be segmented into a 100 GB fast access segment and a 333 GB slower access. With the 3592 Model J1A and EFMT1 (or the 3592 Model E05 and EFMT1), the MEDIA5 cartridge



can be segmented into a 60 GB fast access segment and a 200 GB slower access segment. The segmented capacities of the extended length cartridge, MEDIA9, is 700 GB.

With a segmented cartridge still having only one physical partition and one EOF indicator, data can only be written to the slower access segment after the fast access segment has been filled. Once the fast access segment has been filled, any data written will continue into the slower access segment. However, if an application wishes to manage what data is placed in which segment, the application will need to manually track and fill the fast access segment before it can place less frequently accessed data in the slower access segment. IBM application control and management of what data is placed in which segment is not being addressed with this support.

The segmentation format may be of benefit if the amount of data written to a tape cartridge is typically between the economy and longer-length cartridge capacities, with data written in the first segment having faster access times. Additionally, for customers that tend to utilize the full capacity of the cartridge, the segmentation format can be used to maximize performance benefits. Otherwise, with the native format using all of the tape cartridge's wraps, performance degradation can occur when data is written to the last few wraps of the tape.

---

## **z/OS software support for the 3592 Model E05 tape drive**

Use z/OS software with the 3592 Model E05 to increase your data storage capacity with the IBM System Storage family of tape media and the EFMT2 recording technology. Table 43 describes z/OS DFSMS components, Multiple Virtual Storage (MVS) Device Allocation, Environmental Recording, Editing, and Printing (EREP), DFSORT, and JES3 that provide software support for the 3592 Model E05.

*Table 43. Components that provide software support for the 3592 Model E05 tape drive*

<b>Component</b>	<b>Function</b>
AMS	AMS allows the use of the EFMT1 and EFMT2 recording technology and IBM System Storage family of tape media for volumes as well as the printing and displaying of information about the recording technology and media type.
Device Services	Device Services manages the IBM System Storage Tape System 3592 devices.
DFSORT	DFSORT works without change with the IBM System Storage Tape System 3592 devices.
EREP	EREP provides device type information when formatting LOGREC records.

Table 43. Components that provide software support for the 3592 Model E05 tape drive (continued)

Component	Function
DFSMSHsm	<p>DFSMSHsm allows the use of 3592 devices and media for DFSMSHsm-related activities. Customers can choose to limit the data written to the first 20% (the optimally scaled performance capacity) of the IBM TotalStorage Enterprise Tape Cartridge (MEDIA5 and MEDIA9) by using the data class performance scaling attribute. Alternatively, customers can choose to divide MEDIA5 and MEDIA9 cartridges into a fast access segment to be filled first, and a slower access segment to be filled after, using the performance segmentation attribute. These options are not available on MEDIA6, MEDIA7, MEDIA8, or MEDIA10 tape cartridge media.</p>
ISMF	<p>ISMF allows the use of 3592 devices and media in the ISMF Data Class Application, Mountable Tape Volume Application, and the Tape Library Management Application. In addition, the data class performance scaling attribute, if selected, allows the user to limit the amount of data written to each tape. This applies to MEDIA5 and MEDIA9 tape cartridges and limits the cartridge capacity to 20%. ISMF alternatively allows MEDIA5 and MEDIA9 cartridges to be divided into fast access and slower access segments, using the performance segmentation attribute. The performance scaling and performance segmentation attributes are mutually exclusive for a given cartridge.</p>
z/OS Multiple Virtual Storage (MVS) Allocation	<p>z/OS MVS Allocation allows the use of the EFMT1 and EFMT2 recording technology and IBM System Storage family of tape media when using the Dynamic Allocation Text Unit DALINCHG.</p>

Table 43. Components that provide software support for the 3592 Model E05 tape drive (continued)

Component	Function
OAM	OAM tape library support allows the use of the EFMT1 and EFMT2 recording technology and IBM System Storage family of tape media in the IBM 3494 and 3584 Automated Tape library and in the manual tape library. OAM object tape support allows the use of 3592 devices and media for object-related activity. Customers can also choose to limit the data written to the first 20% (the optimally scaled performance capacity) of the IBM TotalStorage Enterprise Tape Cartridge (MEDIA5 and MEDIA9) by using the data class performance scaling attribute. Alternatively, customers can choose to divide MEDIA5 and MEDIA9 cartridges into a fast access segment to be filled first, and a slower access segment to be filled after, using the performance segmentation attribute. These options are not available on MEDIA6, MEDIA7, MEDIA8, or MEDIA10 tape cartridge media.
OCE/IFGOJES3	OCE/IFGOJES3 allows the use of the EFMT1 and EFMT2 recording technology and IBM System Storage family of tape media in the stand-alone environment and the tape library environment. New devices can also be used in a tape library that is JES3-managed.
DFSMSrmm	DFSMSrmm allows the use of the EFMT1 and EFMT2 recording technology and IBM System Storage family of tape media. DFSMSrmm records the volume capacity for a volume including the volume capacity when performance scaling or performance segmentation is specified. This applies to the IBM TotalStorage Enterprise Tape Cartridge (MEDIA5 and MEDIA9).
SMS	SMS allows the use of the EFMT1 and EFMT2 recording technology and IBM System Storage family of tape media. You can specify the data class performance scaling attribute or the performance segmentation attribute for the IBM TotalStorage Enterprise Tape Cartridge (MEDIA5 and MEDIA9). These options are not available on MEDIA6, MEDIA7, MEDIA8, or MEDIA10 tape cartridge media.

## Using 3592 Model E05 tape drives in an IBM tape library environment

z/OS DFSMS provides device allocation and media management in the 3494 and 3584 automated or manual tape library environments for 3592 Model E05 tape drives. This full support is required when 3592 Model E05 tape drives are installed

in an IBM tape library environment. 3592 Model E05 drives can coexist with 3950 Model B1x, 3590 Model E1x, 3590 Model H1x and 3592 Model J1A drives in the same library; however, depending on the library type and model, certain device types may only be supported in certain libraries. For example, the IBM 3584 automated tape library only supports the 3592 family of tape drives.

Inside an IBM tape library, only 3590 Model B1x emulation is supported. The system-managed tape library support recognizes the device as its real device type instead of its emulated device type; this enables "real" and emulated 3590 Model B1x tape drives to coexist and be properly managed in the same IBM tape library.

To request WORM media in a system-managed tape library environment and to ensure that WORM media is only used when explicitly requested, if a WORM scratch volume is to be used, media types MEDIA6, MEDIA8, or MEDIA10 must be explicitly specified through data class. If a media type is not specified through data class, MEDIA9 is the primary scratch media type, MEDIA5 is the alternate scratch media type if there are no MEDIA9 scratch volumes available, and MEDIA7 is the second alternate scratch media if there are no MEDIA9 or MEDIA5 scratch volumes available.

Before using the new 3592 Model E05, ensure that all existing 3592 Model J1A drives in the library are upgraded to recognize and enable EFMT2-formatted cartridges to be relabelled/reused on the 3592 Model J1A. Otherwise, job failures may occur with a drive with the incorrect microcode load being allocated.

## Using 3592 Model E05 tape drives in a stand-alone environment

3592 Model E05 tape drives emulate already-supported tape devices. To use these drives in a nonlibrary environment, you must manage mixed media and resolve drive allocation ambiguities between 3592 Model E05 drives, the actual models of drives that are being emulated, and other 3590 Model B1x emulated devices. This is because the emulated device type is recorded in the data set records of user catalogs. You must manage media and device allocation according to your installation's storage management policies. You must segregate real and emulated device types.

Before using the new 3592 Model E05, ensure that all existing 3592 Model J1A drives are upgraded to recognize and enable the EFMT2-formatted cartridges to be relabelled/reused on the 3592 Model J1A. Otherwise, job failures may occur with a drive with the incorrect microcode load being allocated.

**Recommendation:** Use a manual tape library, DFSMSrmm, third-party tape management software, or write your own applications when using 3592 Model E05 tape drives in a stand-alone environment.

---

## Resolving recording technology conflicts for 3592

The 3592 Model J1A and E05 tape drives can both write to MEDIA5-MEDIA8 media types, however conflicts occur, when an EFMT2 formatted cartridge is mounted on a EFMT1-only tape drive and is being relabelled/reused.

The OPEN and EOVS routines can resolve these recording technology conflicts if you meet these conditions:

- Set OPEN for output to the first file
- Specify VOLNSNS=YES in the DEVSUPxx member of PARMLIB

- Position the tape cartridge at the load point.

If these conditions are met and if the cartridge has an internal *volser* recorded in its volume control region, OPEN and EOV routines rewrite the VOL1 label with the volume identifier in the sense data.

**Note:** To enable this support, make sure that the 3592 Model J1A devices are at the appropriate microcode level, so that an up-level volume can have its volume identifier returned in the sense data.

For additional information about resolving recording technology conflicts, see *z/OS DFSMS Using Magnetic Tapes* and *z/OS DFSMS Installation Exits*.

---

## Implementation considerations for Using 3592 Model E05 tape drives

Consider these implementation tasks for using DFSMS software support for 3592 Model E05 tape drives.

- For non-specific mount requests in a stand-alone (non-SMS) tape environment, there are no automatic system controls for WORM cartridges. This can result in inadvertent and irreversible writes to WORM media. Using the tape management system pooling support to set up pools to select WORM versus R/W tape media and selecting economy length, standard length, or extended length cartridges help to guarantee that the correct media type is mounted. In addition, SMS data class policies can be used to control WORM mounts for stand-alone, non-specific mount requests. There are two ways to enforce the data class media policy:
  - Specify the DEVSUP $xx$  keyword, ENFORCE\_DC\_MEDIA=ALLMEDIATY. ALLMEDIATY enforces all data class media policies for all stand-alone scratch mounts.
  - Specify the DEVSUP $xx$  keyword, ENFORCE\_DC\_MEDIA=MEDIA5PLUS. MEDIA5PLUS ensures data class media policies for MEDIA5, MEDIA6, MEDIA7, MEDIA8, MEDIA9, and MEDIA10 are enforced for stand-alone scratch mounts.
- In the manual tape library (SMS) environment, WORM scratch mounts can be managed through the tape management system pooling support instead of data class. The DEVSUP $xx$  keyword, MTL\_NO\_DC\_WORM\_OK, allows a WORM scratch volume to be used, even if it was not explicitly requested through data class.
- For the IBM TotalStorage Enterprise Tape Cartridge (MEDIA5 or MEDIA9), use the performance scaling attribute specified through the ISMF data class application if you want to select optimal performance scaling for certain types of jobs and applications. The default setting is to use the tape to its full capacity. This can be specified for tape allocations that are inside or outside an IBM tape library environment. The performance scaling option is not available on MEDIA6, MEDIA7, MEDIA8, or MEDIA10 tape cartridge media.
- For the IBM TotalStorage Enterprise Tape Cartridge (MEDIA5 or MEDIA9), use the performance segmentation attribute specified through the ISMF data class application if you want to divide the cartridge into a fast access segment and a slower access segment. The fast access segment will be filled first, after which the slower segment will be filled. The performance segmentation option is mutually exclusive with the performance scaling option, and is not available on MEDIA6, MEDIA7, MEDIA8, or MEDIA10 tape cartridge media.
- If you have mixed 3590-1 devices in a non-SMS environment, you need to define a unique esoteric name for each recording technology. Identify the esoteric

names to DFSMSHsm using the SETSYS USERUNITTABLE(*esoteric1:esoteric1, esoteric2:esoteric2...*) command to ensure that the correct device type is requested when the tape is mounted for input or output. If your installation uses SMS-managed tape devices or has a single 3590-1 recording technology, you do not need to define an esoteric for those devices; you might need to specify that DFSMSHsm allows mixed devices in the 3590-1 generic name (see APAR OW57282).

- In the stand-alone (non-SMS) environment, perform these implementation steps:
  1. Define data classes or alter existing data classes to:
    - Use the performance scaling attribute or performance segmentation attribute with the IBM TotalStorage Enterprise Tape Cartridge (MEDIA5 or MEDIA9).
    - To take advantage of the data class media enforcement support enabled through DEVSUPxx (ENFORCE\_DC\_MEDIA=ALLMEDIATY or ENFORCE\_DC\_MEDIA=MEDIA5PLUS).
    - As appropriate, use the media interchange recording technology specification (E1) to request that the lower recording format EFMT1 be used. By default, when writing from load point, EFMT2 is used by the 3592 Model E05.
  2. Update the ACS routine to assign the appropriate data class construct.
- In an IBM tape library environment, perform these implementation steps:
  1. Define or alter existing data classes to:
    - Specify the recording technology, media type, performance scaling, and performance segmentation attributes, as appropriate. The performance scaling and segmentation attributes apply to the IBM TotalStorage Enterprise Tape Cartridge (MEDIA5 or MEDIA9). These options are not available on MEDIA6, MEDIA7, MEDIA8, or MEDIA10 tape cartridge media.
    - As appropriate, use the media interchange recording technology specification (E1) to request that the lower recording format EFMT1 be used. By default, when writing from load point, EFMT2 is used by the 3592 Model E05.
  2. Define or alter existing tape storage group constructs.
  3. Update ACS routines to direct allocation to appropriate 3592 devices and media.
  4. Validate and activate the new or modified SMS configuration.
  5. Update parmlib member DEVSUPxx (as appropriate) with the MEDIAx parameters (MEDIA5, MEDIA6, MEDIA7, MEDIA8, MEDIA9, MEDIA10) specifying the library partitioning category codes.

**Related reading:**

See Chapter 41, “Migration to the software support for 3592 Model E05 tape drives,” on page 271 for migration information and implementation information.

---

## Chapter 41. Migration to the software support for 3592 Model E05 tape drives

DFSMS software support for the 3592 Model E05 addresses media management and data allocation in an IBM 3494 Automated Tape Library, in an IBM 3584 Automated Tape Library, and in the manual tape library (MTL). You can manage media and allocate data to appropriate nonlibrary drives through segregation of the real and emulating drives, third-party tape management software, or user-written applications. You can use the 3592 Model E05 drive on systems that are running z/OS V1R4 and above. However, to use the new 3592 media types, MEDIA9 and MEDIA10, z/OS V1R5 and above must be used.

This topic outlines the tasks and associated procedures that must be performed to migrate to software support for the 3592 Model E05 tape drive in these environments:

- Stand-alone environment
- IBM tape library environment
- OAMplex
- HSMplex

---

### Understanding coexistence considerations for 3592 Model E05

Coexistence support for the 3592 Model E05 is provided at z/OS V1R4 and above by installing the needed full-support PTFs without the Device Services enabling PTF. In addition to this, existing device services support (with APAR OA02207) prevents the 3592 Model E05 devices from coming online on a system that does not have all of the full-support PTFs installed. Installation of the Devices Services enabling PTF brings in all of the needed full-support PTFs. You must install the needed coexistence support on systems that will not have all of the 3592 Model E05 support installed. See Table 44 on page 272 for a discussion of the coexistence PTFs that may be needed. For past discussion of the 3592 Model J1A and its coexistence considerations, refer to “Understanding coexistence considerations for 3592 Model J1A” on page 347.

**Note:** Full support for the 3592 Model E05 will first be available on z/OS V1R4 and z/OS V1R5 (refer to enabling APAR OA11388) with support for z/OS V1R6 and z/OS V1R7 available after the initial GA (refer to enabling APAR OA13110). Before using the 3592 Model E05, ensure that the appropriate full support and coexistence support is available for all of your system levels. Planned availability for z/OS V1R6 and z/OS V1R7 is year end 2005.

Review the coexistence migration tasks described in these topics:

Table 44. Coexistence migration tasks for 3592 Model E05

Environment	Coexistence considerations
Stand-Alone	<p>As described in Chapter 40, "Introduction for 3592 Model E05," on page 261, z/OS DFSMS and related licensed programs provide full support for the 3592 Model E05 and MEDIA5, MEDIA6, MEDIA7, and MEDIA8 with z/OS V1R4 and above, with support for the new media types, MEDIA9 and MEDIA10, being provided with z/OS V1R5 and above. The 3592 Model E05 support enables the tape drives to operate in the stand-alone environment in 3590 Model B1x emulation and to coexist with other 3590-1 or 3490 tape drives. However, prior to using the new 3592 Model E05 tape drives, ensure that all existing 3592 Model J1A tape drives have their microcode upgraded to recognize and enable the EFMT2 formatted cartridges to be relabelled/reused on the 3592 Model J1A. Also, ensure that VOLNSNS=YES is in the DEVSUPxx member of PARMLIB. Otherwise, job failures may occur with a drive with the incorrect microcode load being allocated.</p>
IBM Tape Library	<p>As described in Chapter 40, "Introduction for 3592 Model E05," on page 261, z/OS DFSMS and related licensed programs provide full support for the 3592 Model E05 and MEDIA5, MEDIA6, MEDIA7, and MEDIA8, with z/OS V1R4 and above, with support for the new media types, MEDIA9 and MEDIA10, being provided with z/OS V1R5 and above. The system-managed tape library support allows the tape drives to operate in an ATL or MTL environment as 3590 Model B1x devices, providing device allocation and tape media management support. As appropriate for the library type and model, this support allows the 3592 Model E05 tape drives to coexist with other 3590-1 tape drives (3590 Model B, E and H and 3592 Model J) in the same tape library. However, prior to using the new 3592 Model E05 tape drives, ensure that all existing 3592 Model J1A tape drives have their microcode upgraded to recognize and enable the EFMT2 formatted cartridges to be relabelled/reused on the 3592 Model J1A. Also, ensure that VOLNSNS=YES is in the DEVSUPxx member of PARMLIB. Otherwise, job failures may occur with a drive with the incorrect microcode load being allocated.</p>



Table 44. Coexistence migration tasks for 3592 Model E05 (continued)

Environment	Coexistence considerations
OAMplex	<p>For OAM's object support customers, in addition to the planning steps required for migration to the software support for the 3592 Model E05 tape drives in the stand-alone and IBM tape library environments, there are coexistence considerations your installation must take into account before you install the software in an OAMplex:</p> <ul style="list-style-type: none"> <li>• For the 3592 Model E05 support, OAM object tape coexistence support is provided at z/OS V1R4 and above, through installation of the full support PTF without the device services enabling PTF.</li> <li>• OAM coexistence support prevents lower-level systems from selecting volumes with ERDS Physical Identifier (EPI) values for object write requests that are not supported on that system and it also prevents MEDIA9 and MEDIA10 volumes from being selected on a system that is not enabled for the new media support.</li> <li>• OAM object support has coexistence considerations when running in an OAMplex environment with at least one system with the full support installed and enabled and at least one system at a release level where the new devices are supported; however, all of the support is not installed and enabled. In this mixed environment, it is possible for a retrieve request to be received for an object, which resides on a tape cartridge volume which was written in the EFMT2 format, by a system that does not have the 3592 Model E05 support installed, or by a system that supports the 3592 Model E05, but does not support the new media types (MEDIA9 or MEDIA10), or both. Coexistence support is provided that allows OAM to attempt to locate an instance of OAM in the OAMplex where the full support is installed and enabled and also, as applicable, to locate an instance of OAM that supports MEDIA9 and MEDIA10. MEDIA9 and MEDIA10 are only supported on z/OS V1R5 and above. If an instance of OAM is found where the request can be processed, the OAM on the system where the request originated will ship the retrieve request to the target system using XCF messaging services. Once 3592 Model E05 devices are used in an OAMplex environment and objects are written to tape volumes with the new EPI value recorded, it is expected that any OAM on a system where the full support is installed and enabled is eligible for processing requests using that volume with the exception of MEDIA9 and MEDIA10 which require z/OS V1R5 or above. Therefore, the devices must be made available to all instances of OAM where the full support is installed.</li> </ul>
OCE (Open / Close / End-of-Volume)	<p>In support of the new media types (MEDIA9 and MEDIA10), coexistence support is provided for the new media types on z/OS V1R4 to prevent the new media types from being used on a non-supporting system. With the coexistence support installed, an abend will occur if a MEDIA9 or MEDIA10 volume is mounted on a non-supporting system.</p>
HSMplex	<p>For the 3592 Model E05 support, HSM coexistence support is provided at z/OS V1R4 and above, through installation of the full support HSM PTF without the device services enabling PTF. This allows the coexisting system to reject partial tapes written by the 3592 Model E05 in EFMT2. HSM coexistence support for the new media types (MEDIA9 and MEDIA10) is provided at the z/OS V1R4 level by applying both the OCE and HSM full support PTFs. This will ensure that HSM does not use MEDIA9 or MEDIA10 on a non-supporting system.</p>

## Preparing to install the software

See *IBM System Storage TS1120 Tape Drive and Controller Introduction and Planning Guide*, GA32-0555 for hardware requirements.

Coexistence support for the 3592 Model E05 is provided with z/OS V1R4 and above by installing the appropriate full support PTFs without the device services enabling PTF. Coexistence support is also provided for the new media types (MEDIA9 and MEDIA10) at z/OS V1R4 to handle requests for MEDIA9 and MEDIA10 on a non-supporting system. MEDIA9 and MEDIA10 are only supported on z/OS V1R5 and above.

---

## Installing the appropriate PTFs

Refer to the 3592 PSP bucket for the APAR and PTF numbers applicable for each release. An enabling PTF exists to provide full device support for the 3592 Model E05. Installation of the appropriate enabling PTF pulls in all of the needed support PTFs and indicates to the system that all of the needed software support is installed. Support for z/OS V1R4 and z/OS V1R5 will be provided first with support for z/OS V1R6 and z/OS V1R7 following after the initial GA. With this split GA, in an OAMplex or an HSMplex, before using the 3592 Model E05, ensure that the appropriate support is available and installed at all of the release levels used in the plex.

In addition, as appropriate for your environment and release level, determine what coexistence PTFs are needed for your environment.

---

## Planning for DFSMS software support for the 3592 Model E05

The planning steps you must consider to successfully install the 3592 Model E05 software, vary depending upon the tape environment you have installed. Also remember that the 3592 Model E05 is supported on z/OS V1R4 with the existing media types (MEDIA5 through MEDIA8), however the new media types MEDIA9 and MEDIA10 are only supported on z/OS V1R5 and above. Table 45 discusses planning considerations for stand-alone environments (including tape devices installed in vendors' automated tape libraries) and for IBM tape library environments.

*Table 45. 3592 Model E05 planning considerations*

Area	Planning considerations
System customization: stand-alone environment	<ol style="list-style-type: none"> <li>1. Determine whether you will need help from your tape management system vendor and contact them, if needed.</li> <li>2. Upgrade 3592 Model J drive microcode to enable the drives to recognize and enable the EFMT2 formatted cartridges to be relabelled/reused. Also, ensure that VOLNSNS=YES is in the DEVSUPxx member of PARMLIB.</li> <li>3. With availability of the new media (MEDIA9 and MEDIA10), determine if any microcode updates are needed.</li> <li>4. Determine which systems should have coexistence support and which systems should have full support.</li> <li>5. Determine when to IPL the host machine after installing the coexistence PTFs, if needed.</li> <li>6. Determine when to IPL the host machine after installing all necessary PTFs.</li> </ol>

Table 45. 3592 Model E05 planning considerations (continued)

Area	Planning considerations
System customization: IBM library tape environment	<ol style="list-style-type: none"> <li>1. Determine whether you will need help from your tape management system vendor and contact them, if needed.</li> <li>2. Upgrade 3592 Model J drive microcode to enable the library drives to recognize and enable the EFMT2 formatted cartridges to be relabelled/reused. Also, ensure that VOLNSNS=YES is in the DEVSUPxx member of PARMLIB.</li> <li>3. With availability of the new media (MEDIA9 and MEDIA10), determine if any microcode updates are needed.</li> <li>4. Identify the installation exit changes that are needed.</li> <li>5. Determine which systems should have coexistence support and which systems should have full support.</li> <li>6. Determine when to IPL the host machine after installing the coexistence PTFs, if needed.</li> <li>7. Determine when to IPL the host machine after installing all necessary PTFs.</li> </ol>
System customization: OAM object tape environment	<p>The planning steps that you must consider in tape environments that use OAM objects vary depending upon the type of environment that is installed.</p> <ol style="list-style-type: none"> <li>1. If you install the new 3592 Model E05 devices in a stand-alone environment: <ol style="list-style-type: none"> <li>a. Follow the system customization planning steps listed for a stand-alone environment.</li> <li>b. Determine the esoteric or generic device names that need to be added to STORAGEGROUP statements in the CBROAMxx member of PARMLIB for the object storage groups that are to use the new devices.</li> <li>c. Determine whether to use the global keyword DSNWITHSGNAME on the SETOAM statement in the CBROAMxx member of PARMLIB to append the object storage group name to the OAM object tape data set names. See “Object tape data set low-level qualifier enhancement” on page 413 for additional information.</li> </ol> </li> <li>2. If you install the new 3592 Model E05 devices in an IBM tape library: <ol style="list-style-type: none"> <li>a. Follow the system customization planning considerations listed for an IBM tape library environment.</li> <li>b. Determine the new data classes that need to be defined in STORAGEGROUP statements in the CBROAMxx member of PARMLIB for the object storage groups that are to use the new devices.</li> </ol> </li> <li>3. In addition, if you install the new 3592 Model E05 devices in an OAMplex: <ol style="list-style-type: none"> <li>a. Ensure that the new 3592 Model E05 devices are available to all instances of OAM where the full support software is installed.</li> <li>b. Determine whether systems exist that will require coexistence support. This situation is particularly important in an OAMplex where at least one system has the full-support software installed and enabled, and at least one system will not have all of the support installed or enabled. Coexistence support is needed if not all of the systems in the OAMplex will be at the same full-support level.</li> <li>c. To provide this coexistence support, as appropriate for the support and the release level, install the OAM full-support PTF without the enabling PTF or any separate coexistence support PTF.</li> <li>d. Determine when to IPL the host machine after installing the coexistence PTFs, if needed.</li> </ol> </li> </ol>
System customization: DFSMSHsm	See “Implementation considerations for Using 3592 Model E05 tape drives” on page 269 and “DFSMSHsm tips” on page 313.

Table 45. 3592 Model E05 planning considerations (continued)

Area	Planning considerations
Storage administration: stand-alone tape environment	<ol style="list-style-type: none"> <li>1. Determine how to setup your tape management systems pooling support to segregate rewritable (MEDIA5, MEDIA7, and MEDIA9) and WORM (MEDIA6, MEDIA8, and MEDIA10) media and also to segregate the standard, economy, and extended length cartridges, as appropriate for their job and application usage.</li> <li>2. Review the usage of the DEVSUP:xx PARMLIB option, ENFORCE_DC_MEDIA, (optional) to ensure that the media type mounted is the media type requested through data class. This can be used in conjunction with the tape management systems pooling support as an additional safety check.</li> <li>3. Review the existing SMS data class media policies to ensure compatibility with existing tape scratch pool policies before enabling the DEVSUP:xx PARMLIB option, ENFORCE_DC_MEDIA.</li> <li>4. Review the existing SMS data class recording technology policies to ensure that data set policies set to EFMT1 are being appropriately used. If a 3592 Model E05 is allocated and the specified data class indicates EFMT1, the drive will record in the lower recording technology.</li> <li>5. Determine if media should use performance segmentation, with a fast access segment to be filled first, and a slower access segment to be filled after. If you decide to use the performance segmentation attribute (available with MEDIA5 and MEDIA9 tape cartridges only, and mutually exclusive with performance scaling), you can: <ol style="list-style-type: none"> <li>a. Define a data class that requests performance segmentation.</li> <li>b. Modify or create ACS routines to associate the tape output functions using performance segmentation with a data class that requests performance segmentation.</li> </ol> </li> <li>6. Determine if media should be used at full capacity or scaled for optimal performance. If you decide to use the performance scaling attribute (available with MEDIA5 and MEDIA9 tape cartridges only), you can: <ol style="list-style-type: none"> <li>a. Define a data class that requests performance scaling.</li> <li>b. Modify or create ACS routines to associate the tape output functions using performance scaling with a data class that requests performance scaling.</li> </ol> </li> <li>7. Determine how to allocate media to appropriate nonlibrary drives. Consider using the IBM manual tape library. You can also segregate the real drives from the emulating drives, use third-party tape management software, or use customer-written applications.</li> <li>8. Identify any needed changes to the hardware configuration definition (HCD) to define the new devices.</li> </ol>

Table 45. 3592 Model E05 planning considerations (continued)

Area	Planning considerations
Storage administration: IBM tape library environment	<ol style="list-style-type: none"> <li>1. Review the usage of the DEVSUPxx PARMLIB option, MTL_NO_DC_WORM_OK, if the WORM cartridges in the manual tape library environment will be mounted through use of the tape management systems pooling support versus a data class WORM media specification.</li> <li>2. Determine the 3592 media usage of rewritable (MEDIA5, MEDIA7, and MEDIA9) and WORM (MEDIA6, MEDIA8, and MEDIA10) media and also the usage of the standard, economy, and extended length cartridges. Then make the appropriate data class definition updates to select the appropriate media type. WORM media can only be used if explicitly requested through data class.</li> <li>3. Review ACS routines for changes needed in selecting tape storage groups and libraries that have the new 3592 Model E05 devices.</li> <li>4. Determine the data class updates that are needed to use the recording technology, media type, and performance scaling or performance segmentation data class attribute (performance scaling or segmentation available with MEDIA5 and MEDIA9 tape cartridges only).</li> <li>5. Identify any needed changes to the HCD to define the new devices.</li> <li>6. To define the partitioning category code for MEDIA5, MEDIA6, MEDIA7, MEDIA8, MEDIA9, and MEDIA10 tape cartridges, specify the appropriate parameter of the DEVSUPxx parmlib member.</li> </ol>
Storage administration: OAM object tape environment	<p>The planning steps that you must consider in tape environments that use OAM objects vary depending upon the type of environment that is installed.</p> <ol style="list-style-type: none"> <li>1. If you install the new 3592 Model E05 devices in a stand-alone environment, follow the storage administration planning steps listed for a stand-alone environment.</li> <li>2. If you install the new 3592 Model E05 devices in an IBM tape library:               <ol style="list-style-type: none"> <li>a. Follow the storage administration planning steps listed for an IBM tape library environment.</li> <li>b. Review ACS routines for STORE or CTRANS environments and make any changes needed to ensure proper class assignment.</li> </ol> </li> <li>3. If you install the new 3592 Model E05 devices in an OAMplex, you must make the devices available to all instances of OAM where the full support is installed.</li> </ol>

Implementing this change could affect these areas of your processing environment:

Area	Considerations
Storage Administration	<p>For the new 3592 media support (MEDIA9 and MEDIA10), these NaviQuest sample jobs have been changed for this function:</p> <ul style="list-style-type: none"> <li>• ACJBAD1 is the sample job used to define, alter, or display a data class.</li> <li>• ACJBAIL is the sample job to generate data class list and a data class report.</li> <li>• ACJBAIN is the sample job to generate data class report from a saved list.</li> </ul> <p>ISMF panels have been changed. See <i>z/OS DFSMSdfp Storage Administration</i> for information about the ISMF panel changes. See Chapter 44, "ISMF modifications for 3592 Model E05," on page 305 for information about ISMF support for the 3592 Model E05.</p>

Area	Considerations
Operations	<p>These commands have been updated with this support:</p> <ul style="list-style-type: none"> <li>• DEVSERV QTAPE</li> <li>• DISPLAY SMS,LIBRARY(<i>libname</i>),DETAIL</li> <li>• DISPLAY SMS,OAM</li> <li>• DISPLAY SMS,VOLUME</li> <li>• IDCAMS ALTER LIBRARYENTRY</li> <li>• IDCAMS ALTER VOLUMEENTRY</li> <li>• IDCAMS CREATE LIBRARYENTRY</li> <li>• IDCAMS CREATE VOLUMEENTRY</li> <li>• IDCAMS DCOLLECT</li> <li>• IDCAMS LISTCAT</li> <li>• LIBRARY DISABLE</li> <li>• LIBRARY DISPDRV</li> <li>• LIBRARY ENTER</li> <li>• LIBRARY SETCL</li> </ul>
Auditing	None.
Application development	<p>The mapping macros and installation exits listed have been changed for this function.</p> <ul style="list-style-type: none"> <li>• CBRTDSI - Maps the Tape Device Selection Information</li> <li>• CBRTVI - Maps the Tape Volume Information</li> <li>• CBRUXCPL - Installation Exit CBRUXCUA Parameter List</li> <li>• CBRUXEPL - Installation Exit CBRUXENT Parameter List</li> <li>• CBRUXJPL - Installation Exit CBRUXEJC Parameter List</li> <li>• CBRUXNPL - Installation Exit CBRUXVNL Parameter List</li> <li>• DALINCHG - Dynamic Allocation DALINCHG Text Unit</li> <li>• EDGPL100 - EDGUX100 parameter list</li> <li>• EDGRXEXT - Maps the data set records in the DFSMSrmm extract data set</li> <li>• EDGRVEXT - Maps the volume records in the DFSMSrmm extract data set</li> <li>• EDGSVREC - Maps the DFSMSrmm SMF volume records</li> <li>• IECUCBCX - Maps the Tape UCB Device Class extension</li> <li>• IFGTEP - Maps the installation exit main parameter list</li> <li>• IHADFVT - Maps the data facilities vector table</li> <li>• MSGDISP - Message display list</li> </ul>

Area	Considerations
Diagnostic procedures	<p>The messages listed have been changed for this support.</p> <ul style="list-style-type: none"> <li>• IEA435I</li> <li>• IEC205I</li> <li>• IGF513I</li> <li>• CBR0113I</li> <li>• CBR0114I</li> <li>• CBR0119I</li> <li>• CBR0185I</li> <li>• CBR0203I</li> <li>• CBR1082I</li> <li>• CBR1083I</li> <li>• CBR1084I</li> <li>• CBR1100I</li> <li>• CBR1110I</li> <li>• CBR1180I</li> <li>• CBR1220I</li> <li>• CBR1240I</li> <li>• CBR3660A</li> <li>• CBR4105I</li> <li>• CBR6419I</li> <li>• IGF512I</li> <li>• IGF513I</li> </ul>
Automation products	None.
General use	<p>For DFSMSrmm, use the RMM ADDVOLUME subcommand, the RMM CHANGEVOLUME, and the RMM SEARCHVOLUME subcommand for the recording technology EFMT1 and EFMT2 and for the media types MEDIA5, MEDIA6, MEDIA7, MEDIA8, MEDIA9, and MEDIA10.</p>

## Implementing the DFSMS software support for the 3592 Model E05

To implement the 3592 Model E05 software support, perform the system-level and application-level tasks listed in these tables. **Required** tasks apply to any DFSMS installation enabling the function. **Optional** tasks apply to only specified operating environments or to situations where there is more than one way to set up or enable the function. For more details on the procedures associated with a given task, see the reference listed.

System-level tasks	Condition	Procedure reference
<p><i>Stand-alone tape environment</i></p> <ol style="list-style-type: none"> <li>1. Make any needed changes to the HCD to define the new devices.</li> <li>2. If more than one recording technology is used for the same device type, create a unique esoteric for each of the recording technologies. Use the esoteric unit names in DFSMSHsm to direct allocations uniquely to each group of devices.</li> <li>3. If performance scaling or performance segmentation is used (available with MEDIA5 and MEDIA9 tape cartridges only), update or create ACS routines to assign a data class to tape output functions. For example, for DFSMSHsm, you can filter on single file tape data set names used by DFSMSHsm functions. Define the data class with the performance scaling or performance segmentation attribute.</li> <li>4. Add new device esoteric unit names or generic unit names to STORAGEGROUP statements in the CBROAMxx member of PARMLIB for the object storage groups that are to use the new devices. The esoteric or generic unit name must consist of 3592 Model E05 drives exclusively because the EFMT2 recording technology is not compatible with other recording technologies.</li> <li>5. Install coexistence PTFs as appropriate.</li> <li>6. IPL the system.</li> </ol>	Required	<ul style="list-style-type: none"> <li>• <i>z/OS DFSMS OAM Planning, Installation, and Storage Administration Guide for Object Support</i></li> <li>• <i>z/OS HCD User's Guide</i></li> <li>• <i>z/OS DFSMSHsm Implementation and Customization Guide</i></li> </ul>
<p><i>IBM tape library environment</i></p> <ol style="list-style-type: none"> <li>1. Define or alter existing data class constructs as appropriate, to specify the EFMT1 or EFMT2 recording technology, MEDIA5, MEDIA6, MEDIA7, or MEDIA8, MEDIA9, or MEDIA10 media type, and the performance attributes (performance scaling or performance segmentation available with MEDIA5 and MEDIA9 tape cartridges only).</li> <li>2. Define or alter existing storage group constructs to include libraries with the new 3592 Model E05 devices.</li> <li>3. Update ACS routines to direct allocation to the 3592 Model E05 device as requested.</li> <li>4. Validate and activate any new or modified SMS configuration.</li> <li>5. Make any needed changes to the HCD to define the new devices.</li> <li>6. To define the partitioning category code for MEDIA5 MEDIA6, MEDIA7, or MEDIA8, MEDIA9, or MEDIA10 tape cartridges, specify the appropriate parameter of the DEVSUPxx parmlib member.</li> <li>7. When systems are sharing a library with 3592 Model J devices installed, install coexistence PTFs as appropriate.</li> <li>8. IPL the system.</li> </ol>	Required	<ul style="list-style-type: none"> <li>• <i>z/OS DFSMS OAM Planning, Installation, and Storage Administration Guide for Tape Libraries</i></li> <li>• <i>z/OS HCD User's Guide</i></li> <li>• <i>z/OS DFSMSdfp Storage Administration</i></li> </ul>



System-level tasks	Condition	Procedure reference
<p data-bbox="188 216 456 245"><i>OAM object tape environment</i></p> <p data-bbox="188 266 821 342">The migration steps that you must take in tape environments that use OAM objects vary depending upon the type of environment that is installed:</p> <ol data-bbox="188 352 821 1402" style="list-style-type: none"> <li data-bbox="188 352 821 646">1. If you install the new 3592 Model E05 devices in an OAMplex: <ol data-bbox="224 384 821 646" style="list-style-type: none"> <li data-bbox="224 384 821 468">a. Make the new 3592 Model E05 devices available to all instances of OAM where the full support software is installed.</li> <li data-bbox="224 478 821 508">b. Install coexistence PTFs as appropriate.</li> <li data-bbox="224 518 821 615">c. Consider setting DSNWITHSGNAME in the SETOAM statement in the CBROAMxx PARMLIB member. Review your ACS routines if appending the storage group name to OAM data set names (DSNWITHSGNAME).</li> <li data-bbox="224 625 821 646">d. IPL the system.</li> </ol> </li> <li data-bbox="188 657 821 919">2. If you install the new 3592 Model E05 devices in an IBM tape library: <ol data-bbox="224 720 821 919" style="list-style-type: none"> <li data-bbox="224 720 821 770">a. Follow the migration steps listed for an IBM tape library environment.</li> <li data-bbox="224 781 821 856">b. Define the new data classes in STORAGEGROUP statements in the CBROAMxx member of PARMLIB for the object storage groups that are to use the new devices.</li> <li data-bbox="224 867 821 919">c. Make the needed changes to ACS routines for ALLOC, STORE, or CTRANS environments.</li> </ol> </li> <li data-bbox="188 930 821 1402">3. If you install the new 3592 Model E05 devices in a stand-alone environment: <ol data-bbox="224 982 821 1402" style="list-style-type: none"> <li data-bbox="224 982 821 1033">a. Follow the migration steps listed for a stand-alone environment.</li> <li data-bbox="224 1043 821 1234">b. Add new device esoteric unit names or generic unit names to STORAGEGROUP statements in the CBROAMxx member of PARMLIB for the object storage groups that are to use the new devices. The esoteric or generic unit name must consist of 3592 Model E05 drives exclusively because the EFMT2 recording technology is not compatible with other recording technologies.</li> <li data-bbox="224 1245 821 1341">c. Consider setting DSNWITHSGNAME in the SETOAM statement in the CBROAMxx PARMLIB member. Review your ACS routines if appending the storage group name to OAM data set names (DSNWITHSGNAME).</li> <li data-bbox="224 1352 821 1402">d. Make the needed changes to ACS routines for ALLOC, STORE and CTRANS environments.</li> </ol> </li> </ol>	Required	<p data-bbox="1065 216 1448 300"><i>z/OS DFSMS OAM Planning, Installation, and Storage Administration Guide for Object Support</i></p>
<p data-bbox="188 1413 456 1442"><i>DFSMSHsm tape environment</i></p> <p data-bbox="188 1463 821 1568">DFSMSHsm allows the specification of tape unit names using either generic or esoteric names. Installations that have a mixture of non-SMS-managed 3590 devices defined under the 3590-1 generic name, need to perform these steps:</p> <ol data-bbox="188 1579 821 1797" style="list-style-type: none"> <li data-bbox="188 1579 821 1608">1. Define a unique esoteric for each recording technology.</li> <li data-bbox="188 1619 821 1797">2. Use the SETSYS USERUNITTABLE command to define these esoteric names to DFSMSHsm. This also applies to mixed devices in the 3490 generic. Installations that use SMS-managed tape devices or have a single 3590-1 recording technology, do not need to define an esoteric for those devices. However, if you have a mixed SMS-managed 3590 environment, please review APAR OW57282.</li> </ol>	Required	<ul data-bbox="1065 1413 1448 1539" style="list-style-type: none"> <li data-bbox="1065 1413 1448 1476">• <i>z/OS DFSMSHsm Implementation and Customization Guide</i></li> <li data-bbox="1065 1486 1448 1539">• <i>z/OS DFSMSHsm Storage Administration</i></li> </ul>

System-level tasks	Condition	Procedure reference
<p data-bbox="155 218 756 243"><i>Setting up DFSMShsm to use WORM output tapes for ABACKUP</i></p> <p data-bbox="155 268 792 449">In a SMS tape environment, and optionally in a non-SMS tape environment, the SMS data class construct can be used to select WORM tapes for ABACKUP processing. The output data set prefix specified in the aggregate group definition can be used by the ACS routines to select a WORM data class. Set up the ACS routine and the output data set name to uniquely identify the ABARS output files that must go to WORM tape.</p> <p data-bbox="155 474 802 655">In a non-SMS tape environment, the default allows tape pooling to determine if ABARS data sets go to WORM or R/W media. Optionally, if the DEVSUP:xx parameter, ENFORCE_DC_MEDIA=ALLMEDIATY or ENFORCE_DC_MEDIA=MEDIA5PLUS, is used, then the data class must request the appropriate media type for it to be successfully mounted.</p>	Required	<ul style="list-style-type: none"> <li data-bbox="1036 218 1403 277">• <i>z/OS DFSMShsm Implementation and Customization Guide</i></li> <li data-bbox="1036 285 1403 336">• <i>z/OS DFSMShsm Storage Administration</i></li> </ul>
Application-level tasks	Condition	Procedure reference
<p data-bbox="155 743 792 894">For programs that use dynamic allocation and cannot take advantage of predefined data class definitions, set the PARM for the DALINCHG text unit key in DALINCHG to specify the media type and recording technology for system-managed tape library allocations.</p>	Optional	<p data-bbox="1036 743 1403 802"><i>z/OS MVS Programming: Authorized Assembler Services Guide</i></p>

---

## Chapter 42. Access method services (AMS) modifications for 3592 Model E05

This topic describes changes to the access method services (AMS) commands to support the 3592 Model E05 tape drives. These commands are changed.

- “ALTER LIBRARYENTRY”
- “ALTER VOLUMEENTRY” on page 286
- “CREATE LIBRARYENTRY” on page 289
- “CREATE VOLUMEENTRY” on page 292
- “DCOLLECT” on page 295
- “LISTCAT” on page 297

**Attention:** Use these AMS commands only to recover from tape volume catalog errors. Because AMS cannot change the library manager inventory in an automated tape library, use ISMF for normal tape library alter functions.

**Related reading:**

For explanations of all the parameters used with the AMS commands and additional examples, refer to *z/OS DFSMS Access Method Services Commands*.

---

### ALTER LIBRARYENTRY

Use the AMS ALTER LIBRARYENTRY command to modify the attributes for an existing tape library entry.

#### ALTER LIBRARYENTRY command syntax

The syntax for the AMS ALTER LIBRARYENTRY command is as follows.

Keyword	Operands
ALTER	<i>entryname</i> LIBRARYENTRY [CONSOLENAME( <i>consolename</i> )] [DESCRIPTION( <i>desc</i> )] [LIBDEVTYPE( <i>devtype</i> )] [LIBRARYID( <i>libid</i> )] [LOGICALTYPE{AUTOMATED   MANUAL}] [NULLIFY([LIBDEVTYPE][LOGICALTYPE])] [NUMBEREMPTYLOTS( <i>numslots</i> )] [NUMBERSCRATCHVOLUMES(MEDIA1( <i>num</i> ) MEDIA2( <i>num</i> ) MEDIA3( <i>num</i> ) MEDIA4( <i>num</i> ) MEDIA5( <i>num</i> ) MEDIA6( <i>num</i> ) MEDIA7( <i>num</i> ) MEDIA8( <i>num</i> ) MEDIA9( <i>num</i> ) MEDIA10( <i>num</i> ))] [NUMBERSLOTS( <i>numslots</i> )] [SCRATCHTHRESHOLD(MEDIA1( <i>num</i> ) MEDIA2( <i>num</i> ) MEDIA3( <i>num</i> ) MEDIA4( <i>num</i> ) MEDIA5( <i>num</i> ) MEDIA6( <i>num</i> ) MEDIA7( <i>num</i> ) MEDIA8( <i>num</i> ) MEDIA9( <i>num</i> ) MEDIA10( <i>num</i> ))]

#### ALTER LIBRARYENTRY parameters

The NUMBERSCRATCHVOLUMES parameter and the SCRATCHTHRESHOLD parameter include the MEDIA9 and MEDIA10 subparameters for the IBM System Storage family of tape media.

```
[NUMBERSCRATCHVOLUMES(MEDIA1(num) MEDIA2(num) MEDIA3(num) MEDIA4(num)  
MEDIA5(num) MEDIA6(num) MEDIA7(num) MEDIA8(num) MEDIA9(num) MEDIA10(num))]
```

Identifies the total number of MEDIA1, MEDIA2, MEDIA3, MEDIA4, MEDIA5, MEDIA6, MEDIA7, MEDIA8, MEDIA9, and MEDIA10 scratch volumes currently available in the given tape library.

**MEDIA1(*num*)**

The number of Cartridge System Tape scratch volumes available. Use a number from 0 to 999999. The default is 0.

**MEDIA2(*num*)**

Specifies the number of Enhanced Capacity Cartridge System Tape scratch volumes available. Use a number from 0 to 999999. The default is 0.

**MEDIA3(*num*)**

The number of High Performance Cartridge Tape scratch volumes available. Use a number from 0 to 999999. The default is 0.

**MEDIA4(*num*)**

Specifies the number of IBM Extended High Performance Cartridge Tape scratch volumes available. Use a number from 0 to 999999. The default is 0.

**MEDIA5(*num*)**

Specifies the number of IBM TotalStorage Enterprise Tape Cartridge scratch volumes available. Use a number from 0 to 999999. The default is 0.

**MEDIA6(*num*)**

Specifies the number of IBM TotalStorage Enterprise WORM Tape Cartridge scratch volumes available. Use a number from 0 to 999999. The default is 0.

**MEDIA7(*num*)**

Specifies the number of IBM TotalStorage Enterprise Economy Tape Cartridge scratch volumes available. Use a number from 0 to 999999. The default is 0.

**MEDIA8(*num*)**

Specifies the number of IBM TotalStorage Enterprise Economy WORM Tape Cartridge scratch volumes available. Use a number from 0 to 999999. The default is 0.

**MEDIA9(*num*)**

Specifies the number of IBM TotalStorage Enterprise Extended Tape Cartridge scratch volumes available. Use a number from 0 to 999999. The default is 0.

**MEDIA10(*num*)**

Specifies the number of IBM TotalStorage Enterprise Extended WORM Tape Cartridge scratch volumes available. Use a number from 0 to 999999. The default is 0.

**Abbreviation:** NUMSCRV

**[SCRATCHTHRESHOLD(MEDIA1(*num*) MEDIA2(*num*) MEDIA3(*num*) MEDIA4(*num*) MEDIA5(*num*) MEDIA6(*num*) MEDIA7(*num*) MEDIA8(*num*) MEDIA9(*num*) MEDIA10(*num*))]**

Identifies the scratch volume message threshold. When the number of scratch volumes in the tape library falls below the scratch threshold, an operator action message, requesting that scratch volumes be entered into the tape library, is issued to the library's console. When the number of scratch volumes exceeds twice the scratch threshold, the message is removed from the console.

**MEDIA1(*num*)**

Specifies the threshold number of Cartridge System Tape scratch volumes. Use a number from 0 to 999999. The default is 0.

**MEDIA2(num)**

Specifies the threshold number of Enhanced Capacity System Tape scratch volumes. Use a number from 0 to 999999. The default is 0.

**MEDIA3(num)**

Specifies the threshold number of High Performance Cartridge Tape scratch volumes. Use a number from 0 to 999999. The default is 0.

**MEDIA4(num)**

Specifies the threshold number of IBM Extended High Performance Cartridge Tape scratch volumes. Use a number from 0 to 999999. The default is 0.

**MEDIA5(num)**

Specifies the threshold number of IBM TotalStorage Enterprise Tape Cartridge scratch volumes. Use a number from 0 to 999999. The default is 0.

**MEDIA6(num)**

Specifies the threshold number of IBM TotalStorage Enterprise WORM Tape Cartridge scratch volumes. Use a number from 0 to 999999. The default is 0.

**MEDIA7(num)**

Specifies the threshold number of IBM TotalStorage Enterprise Economy Tape Cartridge scratch volumes. Use a number from 0 to 999999. The default is 0.

**MEDIA8(num)**

Specifies the threshold number of IBM TotalStorage Enterprise Economy WORM Tape Cartridge scratch volumes. Use a number from 0 to 999999. The default is 0.

**MEDIA9(num)**

Specifies the threshold number of IBM TotalStorage Enterprise Extended Tape Cartridge scratch volumes. Use a number from 0 to 999999. The default is 0.

**MEDIA10(num)**

Specifies the threshold number of IBM TotalStorage Enterprise Extended WORM Tape Cartridge scratch volumes. Use a number from 0 to 999999. The default is 0.

**Abbreviation:** SCRTHR

## Altering a tape library entry example

This example alters the entry for the tape library ATLLIB1.

```
//ALTERLIB JOB ...
//STEP1 EXEC PGM=IDCAMS
//SYSPRINT DD SYSOUT=A
//SYSIN DD *
ALTER ATLLIB1 -
LIBRARYENTRY -
NUMBEREMPTYSLOTS(2574) -
NUMBERSCRATCHVOLUMES(MEDIA9(500) MEDIA2(400)) -
SCRATCHTHRESHOLD(MEDIA9(200) MEDIA2(100))
```

/\*

This command has these parameters:

- ATLLIB1 is the name of the entry being altered.

- LIBRARYENTRY alters a tape library entry.
- NUMBEREMPTYLOTS sets the number of empty slots to 2574.
- NUMBERSCRATCHVOLUMES sets the current number of scratch volumes available for MEDIA9 to 500 and for MEDIA2 to 400.
- SCRATCHTHRESHOLD sets the threshold number of scratch volumes for MEDIA9 to 200 and for MEDIA2 to 100.

## ALTER VOLUMEENTRY

Use the AMS ALTER VOLUMEENTRY command to modify the attributes for an existing tape volume entry.

### ALTER VOLUMEENTRY command syntax

The syntax of the ALTER VOLUMEENTRY command is as follows:

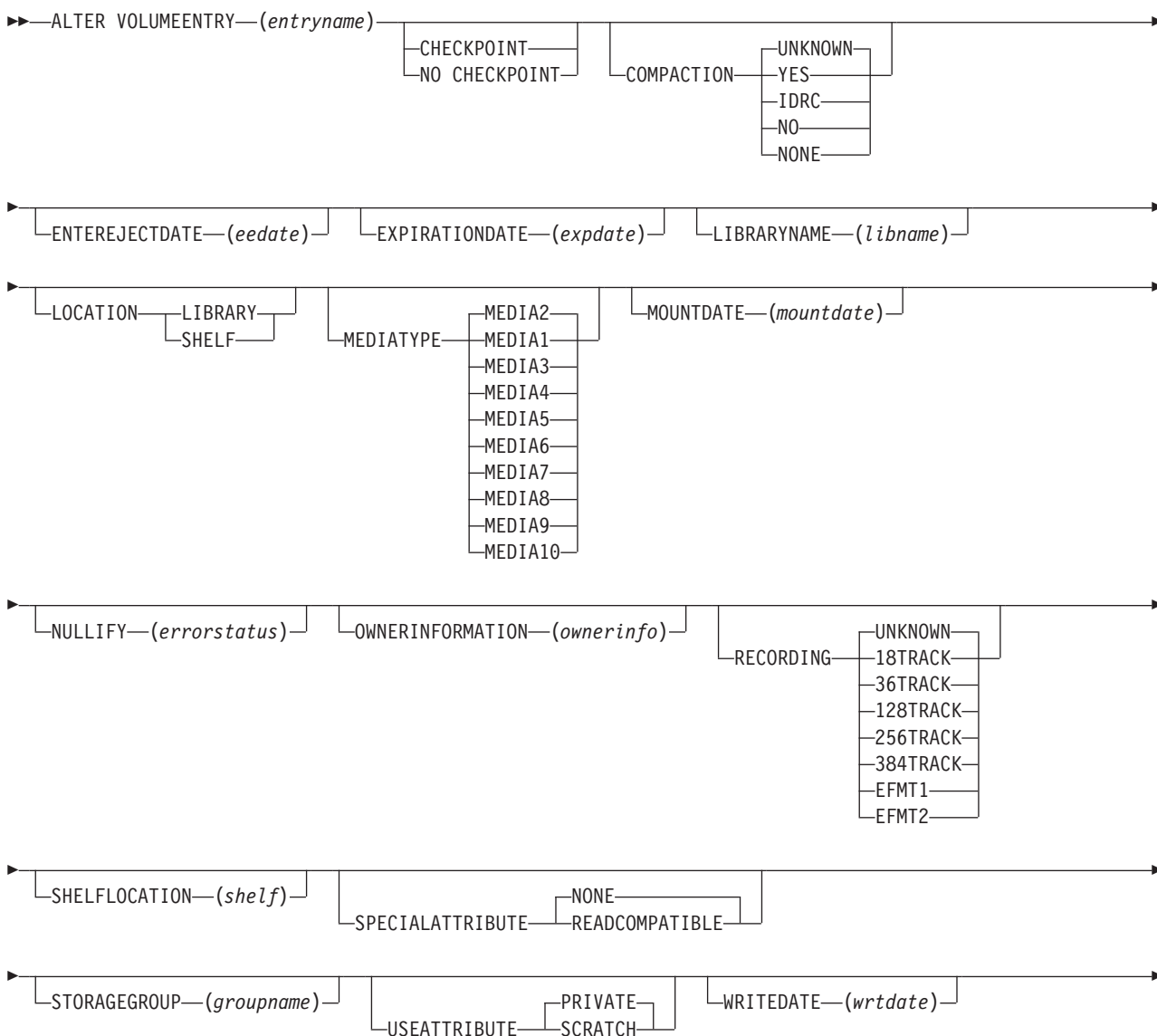

## ALTER VOLUMEENTRY parameters

**MEDIATYPE** and **RECORDING** are optional parameters. The **MEDIATYPE** and the **RECORDING** parameters now include the additional subparameters **MEDIA9**, **MEDIA10**, and **EFMT2** for the 3592 Model E05 tape drive.

**MEDIATYPE**{ **MEDIA1** | **MEDIA2** | **MEDIA3** | **MEDIA4** | **MEDIA5** | **MEDIA6** | **MEDIA7** | **MEDIA8** | **MEDIA9** | **MEDIA10**}

Identifies the media type of the tape volume. If you do not use this, **MEDIATYPE** defaults to **MEDIA2**.

### **MEDIA1**

Specifies that the tape volume is Cartridge System Tape.

### **MEDIA2**

Specifies that the tape volume is Enhanced Capacity System Tape. You cannot use this parameter when **SPECIALATTRIBUTE** is **READCOMPATIBLE** or when **RECORDING** is set to **18TRACK**.

### **MEDIA3**

Specifies that the tape volume is High Performance Cartridge Tape.

### **MEDIA4**

Specifies that the tape volume is IBM Extended High Performance Cartridge Tape.

### **MEDIA5**

Specifies that the volume is IBM TotalStorage Enterprise Tape Cartridge.

### **MEDIA6**

Specifies that the volume is IBM TotalStorage Enterprise WORM Tape Cartridge.

### **MEDIA7**

Specifies that the volume is IBM TotalStorage Enterprise Economy Tape Cartridge.

### **MEDIA8**

Specifies that the volume is IBM TotalStorage Enterprise Economy WORM Tape Cartridge.

### **MEDIA9**

Specifies that the volume is IBM TotalStorage Enterprise Extended Tape Cartridge.

### **MEDIA10**

Specifies that the volume is IBM TotalStorage Enterprise Extended WORM Tape Cartridge.

**Abbreviation:** MTYPE

**[RECORDING**{**18TRACK** | **36TRACK** | **128TRACK** | **256TRACK** | **384TRACK** | **EFMT1** | **EFMT2** | **UNKNOWN**}]

Identifies the tape recording technology. This parameter can be used only for private tape volumes. The default for scratch tape volumes is **UNKNOWN**.

**18TRACK**

Tape was written on an 18-track device and must be read on an 18-track device or a 36-track device.

**36TRACK**

Tape was written and must be read on a 36-track device.

**128TRACK**

Tape was written on a 128-track device and must be read on a 128-track, 256-track, or 384-track device.

**256TRACK**

Tape was written on a 256-track device and must be read on a 256-track device or a 384-track device.

**Note:** 128TRACK and 256TRACK are valid only with **MEDIATYPE(MEDIA3)** or **MEDIATYPE(MEDIA4)**.

**384TRACK**

Tape was written and must be read on a 384-track device.

**Note:** 384TRACK is valid only with **MEDIATYPE(MEDIA3)** or **MEDIATYPE(MEDIA4)**.

**EFMT1**

Tape was written and must be read on an EFMT1 (enterprise format 1) device.

**Note:** EFMT1 is valid only with **MEDIATYPE(MEDIA5)**, (MEDIA6), (MEDIA7), and (MEDIA8).

**EFMT2**

Tape was written and must be read on an EFMT2 (enterprise format 2) device.

**Note:** EFMT2 is valid only with **MEDIATYPE(MEDIA5)**, (MEDIA6), (MEDIA7), (MEDIA8), (MEDIA9), and (MEDIA10).

**UNKNOWN**

Tape recording technology is unknown. This is the default value for scratch tape volumes.

**Abbreviation:** REC

## Altering a volume entry example

This example of the ALTER VOLUMEENTRY command alters the entry name that describes volume 0A2991.

```
//ALTERVOL JOB ...
//STEP1 EXEC PGM=IDCAMS
//SYSPRINT DD SYSOUT=A
//SYSIN DD *
      ALTER VOLUMEENTRY(V0A2991)-
          LIBRARYNAME(ATLIB02)-
          USEATTRIBUTE(SCRATCH)-
          MEDIATYPE(MEDIA9)-
          RECORDING(EFMT2)
```

The parameters that are used in this example are as follows:



- ALTER VOLUMEENTRY indicates that an entry that describes a single volume in a library is being altered.
- V0A2991 specifies that the name of the volume being altered is V0A2991 and that the *volser* is 0A2991.
- LIBRARYNAME specifies that the name of the library with which this volume record is associated is ATLIB02.
- USEATTRIBUTE identifies the volume as being a SCRATCH tape.
- MEDIATYPE specifies the media type as MEDIA9.
- RECORDING specifies the recording technology as EFMT2.

## CREATE LIBRARYENTRY

Use the AMS CREATE LIBRARYENTRY command to create a tape library entry. Use it only to recover from tape volume catalog errors.

### CREATE LIBRARYENTRY command syntax

The syntax for the CREATE LIBRARY command is:

Keyword	Operands
CREATE	<b>LIBRARYENTRY</b> (NAME( <i>entryname</i> ) LIBRARYID( <i>libid</i> ) [CONSOLENAME( <i>consolename</i> )] [DESCRIPTION( <i>desc</i> )] [LIBDEVTYPE( <i>devtype</i> )] [LOGICALTYPE{AUTOMATED   MANUAL}] [NUMBEREMPTYSLOTS( <i>numslots</i> ): [NUMBERSCRATCHVOLUMES(MEDIA1( <i>num</i> ) MEDIA2( <i>num</i> ) MEDIA3( <i>num</i> ) MEDIA4( <i>num</i> ) MEDIA5( <i>num</i> ) MEDIA6( <i>num</i> ) MEDIA7( <i>num</i> ) MEDIA8( <i>num</i> ) MEDIA9( <i>num</i> ) MEDIA10( <i>num</i> ))] ) [NUMBERSLOTS( <i>numslots</i> )] [SCRATCHTHRESHOLD(MEDIA1( <i>num</i> ) MEDIA2( <i>num</i> ) MEDIA3( <i>num</i> ) MEDIA4( <i>num</i> ) MEDIA5( <i>num</i> ) MEDIA6( <i>num</i> ) MEDIA7( <i>num</i> ) MEDIA8( <i>num</i> ) MEDIA9( <i>num</i> ) MEDIA10( <i>num</i> ))] )

### CREATE LIBRARYENTRY parameters

The NUMBERSCRATCHVOLUMES parameter and the SCRATCHTHRESHOLD parameter now include the MEDIA9 and MEDIA10 subparameters for the IBM System Storage family of tape media.

**[NUMBERSCRATCHVOLUMES (MEDIA1 (*num*) MEDIA2 (*num*) MEDIA3 (*num*) MEDIA4 (*num*) MEDIA5 (*num*) MEDIA6 (*num*) MEDIA7 (*num*) MEDIA8 (*num*) MEDIA9 (*num*) MEDIA10 (*num*))] )**

Identifies the total number of MEDIA1, MEDIA2, MEDIA3, MEDIA4, MEDIA5, MEDIA6, MEDIA7, MEDIA8, MEDIA9, and MEDIA10 scratch volumes currently available in the given tape library.

#### **MEDIA1 (*num*)**

Is the number of Cartridge System Tape scratch volumes available. Use a number from 0 to 999999. The default is 0.

#### **MEDIA2 (*num*)**

Specifies the number of Enhanced Capacity Cartridge System Tape scratch volumes available. Use a number from 0 to 999999. The default is 0.

#### **MEDIA3 (*num*)**

Is the number of High Performance Cartridge Tape scratch volumes available. Use a number from 0 to 999999. The default is 0.

**MEDIA4(num)**

Specifies the number of IBM Extended High Performance Cartridge Tape scratch volumes available. Use a number from 0 to 999999. The default is 0.

**MEDIA5(num)**

Specifies the number of IBM TotalStorage Enterprise Tape Cartridge scratch volumes available. Use a number from 0 to 999999. The default is 0.

**MEDIA6(num)**

Specifies the number of IBM TotalStorage Enterprise WORM Tape Cartridge scratch volumes available. Use a number from 0 to 999999. The default is 0.

**MEDIA7(num)**

Specifies the number of IBM TotalStorage Enterprise Economy Tape Cartridge scratch volumes available. Use a number from 0 to 999999. The default is 0.

**MEDIA8(num)**

Specifies the number of IBM TotalStorage Enterprise Economy WORM Tape Cartridge scratch volumes available. Use a number from 0 to 999999. The default is 0.

**MEDIA9(num)**

Specifies the number of IBM TotalStorage Enterprise Extended Tape Cartridge scratch volumes available. Use a number from 0 to 999999. The default is 0.

**MEDIA10(num)**

Specifies the number of IBM TotalStorage Enterprise Extended WORM Tape Cartridge scratch volumes available. Use a number from 0 to 999999. The default is 0.

**Abbreviation:** NUMSCRV

**[SCRATCHTHRESHOLD(MEDIA1(num) MEDIA2(num) MEDIA3(num) MEDIA4(num) MEDIA5(num) MEDIA6(num) MEDIA7(num) MEDIA8(num) MEDIA9(num) MEDIA10(num))]**

Identifies the scratch volume message threshold. When the number of scratch volumes in the tape library falls below the scratch threshold, an operator action message, requesting that scratch volumes be entered into the tape library, is issued to the library console. When the number of scratch volumes exceeds twice the scratch threshold, the message is removed from the console.

**MEDIA1(num)**

Specifies the threshold number of Cartridge System Tape scratch volumes. Use a number from 0 to 999999. The default is 0.

**MEDIA2(num)**

Specifies the threshold number of Enhanced Capacity System Tape scratch volumes. Use a number from 0 to 999999. The default is 0.

**MEDIA3(num)**

Specifies the threshold number of High Performance Cartridge Tape scratch volumes. Use a number from 0 to 999999. The default is 0.

**MEDIA4(num)**

Specifies the threshold number of IBM Extended High Performance Cartridge Tape scratch volumes. Use a number from 0 to 999999. The default is 0.

**MEDIA5(num)**

Specifies the threshold number of IBM TotalStorage Enterprise Tape Cartridge scratch volumes. Use a number from 0 to 999999. The default is 0.

**MEDIA6(num)**

Specifies the threshold number of IBM TotalStorage Enterprise WORM Tape Cartridge scratch volumes. Use a number from 0 to 999999. The default is 0.

**MEDIA7(num)**

Specifies the threshold number of IBM TotalStorage Enterprise Economy Tape Cartridge scratch volumes. Use a number from 0 to 999999. The default is 0.

**MEDIA8(num)**

Specifies the threshold number of IBM TotalStorage Enterprise Economy WORM Tape Cartridge scratch volumes. Use a number from 0 to 999999. The default is 0.

**MEDIA9(num)**

Specifies the threshold number of IBM TotalStorage Enterprise Extended Tape Cartridge scratch volumes. Use a number from 0 to 999999. The default is 0.

**MEDIA10(num)**

Specifies the threshold number of IBM TotalStorage Enterprise Extended WORM Tape Cartridge scratch volumes. Use a number from 0 to 999999. The default is 0.

**Abbreviation:** SCRTHR

## Creating a tape library entry example

The CREATE LIBRARYENTRY command can be used to perform functions shown in this example.

This example creates an entry for a tape library named ATLLIB1.

```
//CREATLIB JOB ...
//STEP1 EXEC PGM=IDCAMS
//SYSPRINT DD SYSOUT=A
//SYSIN DD *
CREATE LIBRARYENTRY -
  (NAME(ATLLIB1) -
  LIBRARYID(12345) -
  LIBDEVTYPE(3494-L10) -
  LOGICALTYPE(AUTOMATED) -
  NUMBERSLOTS(15000) -
  NUMBEREMPTYSLOTS(1000) -
  NUMBERSCRATCHVOLUMES(MEDIA9(500) MEDIA2(400)) -
  SCRATCHTHRESHOLD(MEDIA9(200) MEDIA2(100)) -
  DESCRIPTION('TEST LIBRARY ATLLIB1') -
  CONSOLENAME(TESTCON)

/*
```

The parameters are:

- LIBRARYENTRY creates an entry for a tape library.
- NAME names the tape library ATLLIB1.
- LIBRARYID is the tape library's five-digit hexadecimal serial number, 12345.

- LIBDEVTYPE indicates that the tape library device type is 3494-L10.
- LOGICALTYPE specifies that the tape library is automated.
- NUMBERSLOTS is the total number of slots available in this tape library, 15000.
- NUMBEREMPTYLOTS is the total number of empty slots currently available, 1000.
- NUMBERSCRATCHVOLUMES is the total number of MEDIA9 scratch volumes (500) and MEDIA2 scratch volumes (400).
- SCRATCHTHRESHOLD is the scratch volume threshold for MEDIA9 tape volumes (200) and MEDIA2 tape volumes is (100). When the number of available scratch volumes decreases to these values, an operator action message is issued to the console.
- DESCRIPTION is the description of the tape library.
- CONSOLENAME specifies that TESTCON is the console name.

## CREATE VOLUMEENTRY

Use the AMS CREATE VOLUMEENTRY command to create tape volume entries.

### CREATE VOLUMEENTRY command syntax

The syntax of the CREATE VOLUMEENTRY command is as follows:

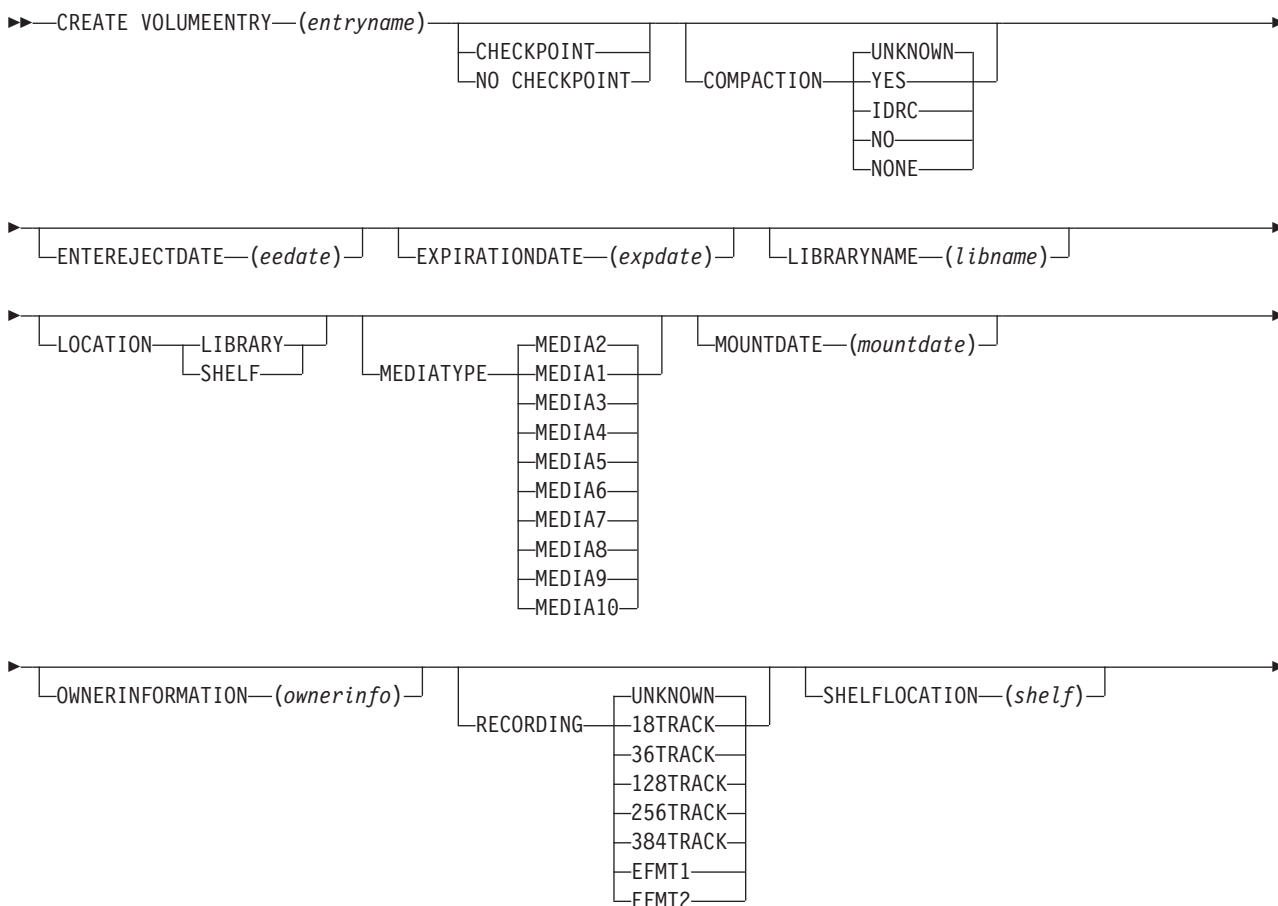

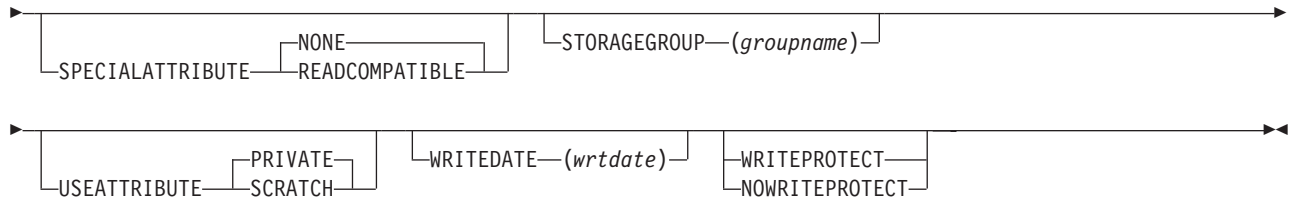

## CREATE VOLUMEENTRY parameters

**MEDIATYPE** and **RECORDING** are optional parameters. The **MEDIATYPE** and **RECORDING** parameters now include the additional subparameters **MEDIA9**, **MEDIA10**, and **EFMT2**.

**MEDIATYPE**{ **MEDIA1** | **MEDIA2** | **MEDIA3** | **MEDIA4** | **MEDIA5** | **MEDIA6** | **MEDIA7** | **MEDIA8** | **MEDIA9** | **MEDIA10**}

Identifies the media type of the tape volume. If you do not use this, **MEDIATYPE** defaults to **MEDIA2**.

### **MEDIA1**

Specifies that the tape volume is Cartridge System Tape.

### **MEDIA2**

Specifies that the tape volume is Enhanced Capacity System Tape. You cannot use this parameter when **SPECIALATTRIBUTE** is **READCOMPATIBLE**, or **RECORDING** is set to **18TRACK**.

### **MEDIA3**

Specifies that the tape volume is High Performance Cartridge Tape.

### **MEDIA4**

Specifies that the tape volume is IBM Extended High Performance Cartridge Tape.

### **MEDIA5**

Specifies that the tape volume is IBM TotalStorage Enterprise Tape Cartridge.

### **MEDIA6**

Specifies that the tape volume is IBM TotalStorage Enterprise WORM Tape Cartridge.

### **MEDIA7**

Specifies that the tape volume is IBM TotalStorage Enterprise Economy Tape Cartridge.

### **MEDIA8**

Specifies that the tape volume is IBM TotalStorage Enterprise Economy WORM Tape Cartridge.

### **MEDIA9**

Specifies that the tape volume is IBM TotalStorage Enterprise Extended Tape Cartridge.

### **MEDIA10**

Specifies that the tape volume is IBM TotalStorage Enterprise Extended WORM Tape Cartridge.

**Abbreviation:** MTYPE

[RECORDING{18TRACK|36TRACK|128TRACK|  
256TRACK|384TRACK|EFMT1|EFMT2|UNKNOWN}]

Identifies the tape recording technology. This parameter can be used only for private tape volumes. The default for scratch tape volumes is UNKNOWN.

**18TRACK**

Tape was written on an 18-track device and must be read on an 18-track device or a 36-track device.

**36TRACK**

Tape was written and must be read on a 36-track device.

**128TRACK**

Tape was written on a 128-track device and must be read on a 128-track, 256-track, or 384-track device.

**256TRACK**

Tape was written on a 256-track device and must be read on a 256-track device or a 384-track device.

**Note:** 128TRACK and 256TRACK are valid only with **MEDIATYPE(MEDIA3)** or **MEDIATYPE(MEDIA4)**.

**384TRACK**

Tape was written and must be read on a 384-track device.

**Note:** 384TRACK is valid only with **MEDIATYPE(MEDIA3)** or **MEDIATYPE(MEDIA4)**.

**EFMT1**

Tape was written and must be read on an EFMT1 (enterprise format 1) device.

**Note:** EFMT1 is valid only with **MEDIATYPE(MEDIA5)**, **(MEDIA6)**, **(MEDIA7)**, and **(MEDIA8)**.

**EFMT2**

Tape was written and must be read on an EFMT2 (enterprise format 2) device.

**Note:** EFMT2 is valid only with **MEDIATYPE(MEDIA5)**, **(MEDIA6)**, **(MEDIA7)**, **(MEDIA8)**, **(MEDIA9)**, and **(MEDIA10)**.

**UNKNOWN**

Tape recording technology is unknown. This is the default value for scratch tape volumes.

**Abbreviation:** REC

## Creating a VOLUME entry example

This example of the CREATE VOLUMEENTRY command creates a volume entry for volume 0A2991.

```

//CREATVOL JOB ...
//STEP1 EXEC PGM=IDCAMS
//SYSPRINT DD SYSOUT=A
//SYSIN DD *
        CREATE VOLUMEENTRY (V0A2991)-
            LIBRARYNAME(ATLIB02)-
            USEATTRIBUTE(SCRATCH)-
            MEDIATYPE(MEDIA9)-
            RECORDING(EFMT2)

```

The parameters used in this example are as follows:

- CREATE VOLUMEENTRY indicates that an entry describing a single volume in a library is being created.
- V0A2991 specifies that the name of the volume entry being created is V0A2991 and the *volser* is 0A2991.
- LIBRARYNAME specifies that the name of the library with which this volume record is associated is ATLIB02.
- USEATTRIBUTE identifies the volume as being a SCRATCH tape.
- MEDIATYPE specifies the media type as MEDIA9.
- RECORDING specifies the recording technology as EFMT2.

## DCOLLECT

The DFSMS Data Collection Facility (DCOLLECT) is a function of access method services. DCOLLECT collects data in a sequential file that you can use as input to other programs or applications.

### DCOLLECT command syntax

The syntax of the DCOLLECT command is as follows.

Keyword	Operands
DCOLLECT	<pre> {OUTFILE(<i>ddname</i>)     OUTDATASET(<i>entryname</i>)} {[VOLUMES(<i>volser</i>[ <i>volser</i>...])]   [BACKUPDATA]   [CAPPLANDATA]   [EXCLUDEVOLUMES(<i>volser</i>[ <i>volser</i>...])]   [MIGRATEDATA]   [SMSDATA(SCDSNAME(<i>entryname</i>)   ACTIVE)]   [STORAGEGROUP(<i>sgname</i>[ <i>sgname</i>...])]} [DDCMEDIA{DDCMENUL   DDCMEDA1   DDCMEDA2     DDCMEDA3   DDCMEDA4   DDCMEDA5   DDCMEDA6     DDCMEDA7   DDCMEDA8   DDCMEDA9   DDCMED10}] [DDCRECTE{DDCRTNUL   DDC18TRK   DDC36TRK     DDC128TK   DDC256TK   DDC384TK   DDCEFMT1   DDCEFMT2}] [ERRORLIMIT(<i>value</i>)] [EXITNAME(<i>entrypoint</i>)] [MIGRSNAPALL   MIGRSNAPERR] [NODATAINFO] [NOVOLUMEINFO] [REPLACE   APPEND] </pre>

## DCOLLECT parameters

The optional **DDCMEDIA** parameter and the optional **DDCRECTE** include subparameters for support of the 3592 Model E05 tape drive.

**DDCMEDIA**(**DDCMENUL** | **DDCMEDA1** | **DDCMEDA2** | **DDCMEDA3** | **DDCMEDA4** | **DDCMEDA5** | **DDCMEDA6** | **DDCMEDA7** | **DDCMEDA8** | **DDCMEDA9** | **DDCMED10**)

shows the type and format of the cartridges used for mountable tape data sets used with this data class. It is mapped by one of these attributes:

### **DDCMENUL**

Media type is not specified (NULL). The constant value is 0.

### **DDCMEDA1**

Media type is MEDIA1 (cartridge system tape media). The constant value is 1.

### **DDCMEDA2**

Media type is MEDIA2 (enhanced capacity cartridge tape media). The constant value is 2.

### **DDCMEDA3**

Media type is MEDIA3 (high-performance cartridge tape media). The constant value is 3.

### **DDCMEDA4**

Media type is MEDIA4 (extended high-performance cartridge tape media). The constant value is 4.

### **DDCMEDA5**

Media type is MEDIA5 (Enterprise Tape Cartridge media). The constant value is 5.

### **DDCMEDA6**

Media type is MEDIA6 (Enterprise WORM Tape Cartridge media). The constant value is 6.

### **DDCMEDA7**

Media type is MEDIA7 (Enterprise Economy Tape Cartridge media). The constant value is 7.

### **DDCMEDA8**

Media type is MEDIA8 (Enterprise Economy WORM Tape Cartridge media). The constant value is 8.

### **DDCMEDA9**

Media type is MEDIA9 (Enterprise Extended Tape Cartridge media). The constant value is 9.

### **DDCMED10**

Media type is MEDIA10 (Enterprise Extended WORM Tape Cartridge media). The constant value is 10.

### **DDCRECTE**

(**DDCRTNUL** | **DDC18TRK** | **DDC36TRK** | **DDC128TK** | **DDC256TK** | **DDC384TK** | **DDCEFMT1** | **DDCEFMT2**)

indicates the number of recording tracks on the cartridge used for the mountable tape data sets associated with this data class.

### **DDCRTNUL**

The recording technology is not specified (NULL). The constant value is 0.

### **DDC18TRK**

The recording technology is 18TRACK. The constant value is 1.



**DDC36TRK**

The recording technology is 36TRACK. The constant value is 2.

**DDC128TK**

The recording technology is 128TRACK. The constant value is 3.

**DDC256TK**

The recording technology is 256TRACK. The constant value is 4.

**DDC384TK**

The recording technology is 384TRACK. The constant value is 5.

**DDCEFMT1**

The recording technology is EFMT1. The constant value is 6.

**DDCEFMT2**

The recording technology is EFMT2. The constant value is 7.

**DCOLLECT example**

Refer to *z/OS DFSMS Access Method Services Commands* for several examples of how to use the DCOLLECT function in a batch environment.

**LISTCAT**

Use the AMS LISTCAT command to list catalog entries.

**LISTCAT command syntax**

The syntax for the LISTCAT command remains the same, but its output can include new MEDIATYPE and RECORDING parameter values. The syntax is as follows:

Keyword	Operands
LISTCAT	[ALIAS] [ALTERNATEINDEX] [CLUSTER] [DATA] [GENERATIONDATAGROUP] [INDEX] [LIBRARYENTRIES( <i>libent</i> )] [NONVSAM] [PAGESPACE] [PATH] [USERCATALOG] [VOLUMEENTRIES( <i>volent</i> )] [CREATION( <i>days</i> )] [ENTRIES( <i>entryname</i> [/ <i>password</i> ][ <i>entryname</i> [/ <i>password</i> ],...)]   LEVEL( <i>level</i> )] [EXPIRATION( <i>days</i> )] [FILE( <i>ddname</i> )] [LIBRARY( <i>libname</i> )] [NAME   HISTORY   VOLUME   ALLOCATION   ALL] [OUTFILE( <i>ddname</i> )] [CATALOG( <i>catname</i> )]

**LISTCAT parameters**

The volume recording technology and media type are not parameters that can be specified with the LISTCAT command.

## List tape volume entries sample output

The LISTCAT command displays the values for the RECORDING parameter and the MEDIATYPE parameter. Figure 20 shows EFMT2 as the recording technology and MEDIA9 as the media type used for volume 0A2991.

This example of the LISTCAT command lists all volumes in the ATLIB02 library catalog. The command returns catalog data for only one volume with a volume *entryname* value of V0A2991.

```

LISTCAT -
  VOLUMEENTRIES
  ALL
IDCAMS  SYSTEM SERVICES          TIME: 11:29:12      09/02/05  PAGE    2
                                LISTING FROM CATALOG -- SYS1.VOLCAT.V0
VOLUME-ENTRY----V0A2991
DATA-VOLUME
LIBRARY-----ATLIB02      RECORDING-----EFMT2      ERROR-STATUS-----NOERROR      CREATION-DATE-2002-04-02
                                MEDIA-TYPE-----MEDIA9      USE-ATTRIBUTE-----SCRATCH      ENT-EJ-DATE----- (NULL)
STORAGE-GROUP---*SCRATCH*  COMPACTION----- (YES)      LAST-MOUNTED----- (NULL)
CHECKPOINT----- (NULL)    SP-ATTRIBUTE-----NONE      WRITE-PROTECTED--- (NULL)      LAST-WRITTEN----- (NULL)
LOCATION-----LIBRARY      SHELF-LOC----- (NULL)      EXPIRATION----- (NULL)
OWNER----- (NULL)
IDCAMS  SYSTEM SERVICES          TIME: 11:29:12      09/02/05  PAGE    3
                                LISTING FROM CATALOG -- SYS1.VOLCAT.VGENERAL
  THE NUMBER OF ENTRIES PROCESSED WAS:
    AIX -----0
    ALIAS -----0
    CLUSTER -----0
    DATA -----0
    GDG -----0
    INDEX -----0
    NONVSAM -----0
    PAGESPACE -----0
    PATH -----0
    SPACE -----0
    USERCATALOG -----0
    TAPELIBRARY -----0
    TAPEVOLUME -----1
    TOTAL -----1
  THE NUMBER OF PROTECTED ENTRIES SUPPRESSED WAS 0
IDC0001I FUNCTION COMPLETED, HIGHEST CONDITION CODE WAS 0
IDCAMS  SYSTEM SERVICES          TIME: 11:29:12      09/02/05  PAGE    4
IDC0002I IDCAMS PROCESSING COMPLETE. MAXIMUM CONDITION CODE WAS 0

```

Figure 20. LISTCAT output for 3592 Model E05

The parameters used in this example are as follows:

- VOLUMEENTRIES specifies that information relating to tape volume entries for all volumes in the library are to be listed.
- ALL requires that all information that is associated with the tape volume entries is to be listed.
- LIBRARY specifies that only tape volume entries that are associated with the tape library named ATLIB02 are to be listed.

---

## Chapter 43. Tape drive and tape volume allocation modifications for 3592 Model E05

Changes made to device support, storage management subsystem (SMS), and Multiple Virtual Storage (MVS) device allocation enable you to allocate the tape drives and tape volumes. Within an IBM tape library environment, your system can fully recognize all supported media types and recording technologies. This topic explains these changes:

- “Device support modifications”
- “SMS modifications” on page 302
- “MVS device allocation modifications” on page 303

---

### Device support modifications

z/OS DFSMS device support provides hardware device-specific code, which allows tape drives, tape volumes, and DASD to interface with z/OS DFSMS. Specifically, it provides:

- The interfacing exits to the input/output supervisor (IOS) and EXCP device support code
- Error recovery procedure routines
- Services to acquire and log statistical and error data
- Services to acquire and display device states
- Utilities for functions like initializing tapes

You can use the MVS DEVSERV command to request basic status information on a device, a group of devices, or storage control units. You can use the QTAPE parameter of the DEVSERV command to display tape device information. Use DEVSERV QTAPE to display the real device type and the emulated device type.

With the DEVSERV QTAPE MED (medium) option, you can display information for the device type, media type, and cartridge volume serial number.

The syntax of the DEVSERV QTAPE command with the MED option is as follows:

**DS QT,xxxx,MED,nnn**

*xxxx*

Represents a three-digit or a four-digit device number in hexadecimal format.

*nnn*

Stands for the number of devices, starting at the address *xxxx*, for which the DEVSERV command displays the MED information. The value *nnn* is optional and can be any decimal number from 1 to 256, with 1 as the default value.

Figure 21 on page 300 shows the display content when you issue the DEVSERV QTAPE MED command.

```
-----
----      DS QT MED Display Content      ----
-----
```

```
IEE459I          DEVSERV QTAPE
UNIT RDTYPE EDTYPE EXVLSR INVLSR RMEDIA EMEDIA WWID X
```

Figure 21. DEVSERV QTAPE MED display content

- X UNIT - tape device address
- RDTYPE - real device type
- EDTYPE - emulated device type
- EXVLSR - external volume serial of cartridge
- INVLSR - internal volume serial of cartridge
- RMEDIA - real media type of the volume mounted on the drive
- EMEDIA - emulated media type of the volume mounted on the drive
- WWID - world-wide identifier or world-wide unique cartridge identifier

**Note:**

1. EDTYPE, EXVLSR, INVLSR, RMEDIA, EMEDIA, and WWID are blank if information is not available.
2. Valid values for RMEDIA and EMEDIA are:
  - 1=CST
  - 2=EC-CST
  - 3=3590 STD length tape
  - 4=3590 EXT length tape
  - 5=3592 Enterprise Tape Cartridge
  - 6-W=3592 Enterprise WORM Tape Cartridge
  - 7=3592 Enterprise Economy Tape Cartridge
  - 8-W=3592 Enterprise Economy WORM Tape Cartridge
  - 9=3592 Enterprise Extended Tape Cartridge
  - 10-W=3592 Enterprise Extended WORM Tape Cartridge

RMEDIA and EMEDIA are blank when the media type is not defined or cannot be determined.

These examples show sample output and messages of the DEVSERV QTAPE command, and DEVSERV QTAPE with the MED option command.

Figure 22 shows the output of DS QT,962,MED when a 3592 Model E05 tape drive emulates a 3590 Model B1x tape drive.

```
IEE459I 11.32.31 DEVSERV QTAPE 608
UNIT RDTYPE EDTYPE EXVLSR INVLSR RMEDIA EMEDIA WWID
0962 3592-2 3590-1          10-W 3      85804D003C00000BC211CA0C
```

Figure 22. DS QT,962,MED output

Figure 23 on page 301 shows the output of DS QT,940,MED when a 3592 Model E05 tape drive emulates a 3590 Model B1x tape drive.

```

IEE459I 11.32.31 DEVSERV QTAPE 608
UNIT RDTYPE EDTYPE EXVLSR INVLSR RMEDIA EMEDIA WWID
0940 3592-2 3590-1 003700          9      3

```

Figure 23. DS QT,940 output

Figure 24 shows the output of DS QT,DA0 when a 3592 Model E05 tape drive emulates a 3590 Model B1x tape drive.

```

IEE459I 17.04.39 DEVSERV QTAPE 502
UNIT DTYPE DSTATUS CUTYPE DEVTYPE CU-SERIAL DEV-SERIAL ACL LIBID
0960 3590 ON-RDY 3592J70 3592E05* 0178-09F8A 0178-09F8A

```

Figure 24. DS QT,DA0 output

Figure 25 displays the message that is issued when the input device address is valid, but the device is not a Model B1x, Model E1x, Model H1x, 3592 Model J, 3592 Model E05, or 3490E drive.

```

IEE459I 11.32.31 DEVSERV QTAPE 608
UNIT RDTYPE EDTYPE EXVLSR INVLSR RMEDIA EMEDIA WWID
**** UNLISTED DEVICE(S) AND REASON CODES :
      0B60(10) Y
**** (10) - UNSUPPORTED DEVICE TYPE

```

Figure 25. DS QT,B60,MED message

**Y** Reason Code 10, UNSUPPORTED DEVICE TYPE, is shown when the device type given is not a Model B1x, Model E1x, Model H1x, 3592 Model J, 3592 Model E05, or 3490E drive.

Figure 26 shows the message and reason code 11 that you receive if the input device address and device type are valid, but the device is not ready.

```

IEE459I 11.32.31 DEVSERV QTAPE 608
UNIT RDTYPE EDTYPE EXVLSR INVLSR RMEDIA EMEDIA WWID
**** UNLISTED DEVICE(S) AND REASON CODES :
      0DA0(11) Z
**** (11) - DEVICE NOT READY

```

Figure 26. DS QT,DA0,MED message

A bit DFVTJAG2 is added to the IHADFVT mapping macro that maps the data facilities vector table. When set, it indicates that all of the software support for the 3592 Model E05 drive is on the system. This bit will be set by the enabling module IECTEPTF if it is installed.

System-wide DEVSUPxx parmlib member options control and manage media type selection for Automatic Tape Library (ATL) partitioning: MEDIA5=xxxx, MEDIA6=xxxx, MEDIA7=xxxx, MEDIA8=xxxx, MEDIA9=xxxx, and MEDIA10=xxxx where xxxx is a 4-digit hexadecimal category code.

The IECUCBCX mapping macro is changed to support the 3592 Model E05 tape drive. The EPI values are:

- X'12'--REALJAG2\_EMUL3590

With MSGDISP macro interface, you can specify the message to be displayed and how to display it on magnetic tape devices that have displays. The parameter keyword, MEDIATYPE, can be used with the MOUNT and DEMOUNT keywords to indicate what media type to mount for scratch mounts on MTL devices. The value is specified as a quoted literal, unquoted literal, the address of a 1-byte field containing the value, or the name of the addressable field containing the value. Current valid values for MEDIATYPE are 1 through 10.

Currently there is a single byte limitation for the MEDIATYPE parameter keyword which passes an EBCDIC character representing the media type. This macro will be modified to allow specification of a value up to 10 via the MEDIATYPE keyword, but allowing for future media type values up to 255.

Valid and invalid specifications for MEDIA10 are described as follows:

**VALID specifications**

**Literal (unquoted)**

MEDIATYPE=10

**ADCON**

MEDIATYPE=A(HEX10) where HEX10 is defined as X'0A'

**Register**

MEDIATYPE=(3) where Reg 3 first has to be loaded with the address of HEX10 (e.g., LA R3,HEX10)

**RX Format**

MEDIATYPE=HEX10

**INVALID specifications**

**Quoted Literal**

MEDIATYPE='10'

**Unquoted Literal**

MEDIATYPE=A

**ADCON**

MEDIATYPE=A(CharA) where CharA is defined as EBCDIC 'A'

**Register**

MEDIATYPE=(3) where Reg 3 is first loaded with the address of CharA

**RX Format**

MEDIATYPE=CharA

---

## SMS modifications

SMS automates and centralizes storage management. It automatically assigns service requirements and attributes to data when that data is created. SMS configuration services validate, for example, the recording technology value that ISMF specifies in data class definitions.

MEDIA9 and MEDIA10 will only be supported from z/OS DFSMS V1R5 and above.

SMS will support a new recording technology EFMT2, 2 new media types MEDIA9 and MEDIA10, and a new segmentation format option called 'Performance Segmentation' in Dataclass. This segmentation format option field is only

applicable to media type 5, and the new media type 9. Performance Segmentation is mutually exclusive to the existing performance scaling option which will be verified during SMS validation process. Additionally, the Performance Scaling will also be supported for the new media type 9.

In an IBM tape library environment (automated or manual), use ISMF to specify the:

- EFMT1 recording technology attribute
- EFMT2 recording technology attribute
- Media type of MEDIA5, MEDIA6, MEDIA7, MEDIA8, MEDIA9, or MEDIA10
- Performance scaling or performance segmentation option, if the media type is MEDIA5 or MEDIA9. Media types MEDIA6, MEDIA7, MEDIA8, and MEDIA10 are not scalable or segmentable.

The performance scaling or performance segmentation options can also be specified and used outside of the system-managed tape library environment.

In support of the 3592 Model E05 tape drives, SMS configuration services are updated to validate the recording technology value and the media type value.

---

## MVS device allocation modifications

MVS device allocation helps prioritize and select tape drives to meet the needs of application programs or system functions. Batch (JCL) or dynamic (SVC99) allocation makes these device needs known to MVS device allocation. MVS device allocation selects the appropriate devices and serializes them for the requester to use. It can also request that appropriate volumes be mounted on the allocated devices. It accomplishes these tasks by interfacing with SMS, DEVSERV, OAM, MSGDISP, and other system components.

MVS device allocation currently supports multiple types of tape devices. Within an IBM tape library environment, MVS device allocation considers media types and recording technologies when allocating tape drives and tape volumes. The dynamic allocation (SVC 99) volume interchange text unit (DALINCHG) allows you to specify EFMT1 the recording technology and MEDIA5, MEDIA6, MEDIA7, or MEDIA8 for the media type and EFMT2 for the recording technology and MEDIA5, MEDIA6, MEDIA7, MEDIA8, MEDIA9 and MEDIA10 for the media type. Specification of MEDIA9 or MEDIA10 is only supported on z/OS V1R5 and above.

MVS device allocation:

- Allows you to specify the new media types (MEDIA9, MEDIA10) through Dynamic Allocation Text Unit DALINCHG at z/OS v1r5 and greater.
- Allows the new recording format (EFMT2) to be used with existing media types MEDIA5-MEDIA8 (at all supported releases) and the new media types MEDIA9 and MEDIA10 (at z/OS v1r5 and greater).

See Table 46 for DALINCHG parameter values.

*Table 46. Dynamic allocation (DALINCHG) parameter values for tape cartridge media types*

Parameter value	Media type	Recording technology
75	MEDIA5	EFMT2
65	MEDIA5	EFMT1
05	MEDIA5	No format

Table 46. Dynamic allocation (DALINCHG) parameter values for tape cartridge media types (continued)

Parameter value	Media type	Recording technology
76	MEDIA6	EFMT2
66	MEDIA6	EFMT1
06	MEDIA6	No format
77	MEDIA7	EFMT2
67	MEDIA7	EFMT1
07	MEDIA7	No format
78	MEDIA8	EFMT2
68	MEDIA8	EFMT1
08	MEDIA8	No format
79	MEDIA9	EFMT2
09	MEDIA9	No format
7A	MEDIA10	EFMT2
0A	MEDIA10	No format

**Related reading:**

- See *z/OS MVS System Commands* for more information on the DEVSERV QTAPE command.
- See *z/OS MVS Programming: Authorized Assembler Services Guide* for more information about the DALINCHG parameter.
- See *z/OS DFSMS Installation Exits* for more information about the IECUCBCX mapping macro.



---

## Chapter 44. ISMF modifications for 3592 Model E05

The interactive storage management facility (ISMF) provides a series of applications for storage administrators to define and manage SMS configurations. This topic describes changes to the data class application, the mountable tape volume application, and the tape library management application to support the 3592 Model E05 tape drive.

### Related reading:

- See *z/OS DFSMS OAM Planning, Installation, and Storage Administration Guide for Tape Libraries* for additional information on the ISMF tape library management application.
- See *z/OS DFSMSdfp Storage Administration* for additional information about data classes and the ISMF data class panels.

---

### Data class define and alter panels for 3592 Model E05

A data class is a set of data set allocation attributes and associated values. You can define, alter, display, and list a data class by using the ISMF data class panels. The data class define/alter panel has changed to support the 3592 Model E05 tape drives. In addition to the previously available values, you can now specify:

- The E2 value for the recording technology attribute EFMT2.
- The number 9 as the value for the MEDIA9 media type attribute or 10 as the value for the MEDIA10 media type attribute.
- Performance scaling to obtain faster access to data on MEDIA5 or MEDIA9 media. The other media types are not scalable.
- Performance segmentation to obtain faster access to data on MEDIA5 or MEDIA9 media. Performance segmentation divides the cartridge into a fast access segment and a slower access segment. The other media types do not offer performance segmentation.

---

### Mountable tape volume list panel

The mountable tape volume application enables you to create, save, and restore lists of tape cartridge volumes. It generates lists of mountable tape volumes and their characteristics that are based on the criteria you specify. New media types MEDIA9 and MEDIA10 can now appear in column 8, MEDIA TYPE. EFMT2 can appear in column 9, RECORDING TECHNOLOGY.

---

### Tape library management panels

The tape library management application allows you to define, alter, list and display tape libraries. These panels have been changed to support the 3592 Model E05 tape drives.

- On the TAPE LIBRARY DEFINE panel, new Scratch Threshold fields for MEDIA9 and MEDIA10 have been added.
- On the TAPE LIBRARY ALTER/REDEFINE panel, new Scratch Threshold fields for MEDIA9 and MEDIA10 have been added.
- On the TAPE LIBRARY DISPLAY panel, new Scratch Threshold and Scratch Number fields for MEDIA9 and MEDIA10 have been added.
- On the TAPE LIBRARY LIST panel, new columns have been added:

- MEDIA9 SCR NUM (column 28)
- MEDIA9 SCR THR (column 29)
- MEDIA10 SCR NUM (column 30)
- MEDIA10 SCR THR (column 31)
- Columns previously numbered 28, 29, and 30 are now numbered 32, 33, and 34
- On page 1 of the TAPE LIBRARY PRINT ENTRY panel, columns previously numbered 28, 29, and 30 are now numbered 32, 33, and 34.  
On page 2 of the TAPE LIBRARY PRINT ENTRY panel, new columns have been added:
  - (28) Media9 Scratch Number
  - (29) Media9 Scratch Threshold
  - (30) Media10 Scratch Number
  - (31) Media10 Scratch Threshold
- On the TAPE LIBRARY SORT ENTRY panel, new columns have been added:
  - (28) Media9 Scratch Number
  - (29) Media9 Scratch Threshold
  - (30) Media10 Scratch Number
  - (31) Media10 Scratch Threshold
- On the TAPE LIBRARY VIEW ENTRY panel, new columns have been added:
  - (28) Media9 Scratch Number
  - (29) Media9 Scratch Threshold
  - (30) Media10 Scratch Number
  - (31) Media10 Scratch Threshold
  - Columns previously numbered 28, 29, and 30 are now numbered 32, 33, and 34

---

## Chapter 45. OCE modifications for 3592 Model E05

The z/OS DFSMS Open/Close/End-of-Volume (OCE) component is a set of system routines that builds the control block structure that connects the application, access method, and the operating system. OCE modifications include passing the media type and recording technology to DFSMS, DFSMSrmm, OAM/Library Automation Communication Services, and to the tape installation exits. OCE also supports performance scaling and performance segmentation with MEDIA5 and MEDIA9 cartridges and also ensures that performance scaling or performance segmentation persists across all volumes of a multivolume data set. During CLOSE of file sequence 1 on a performance scaled or performance segmented cartridge, performance scaling or performance segmentation is externalized in message IEC205I.

The OCE routines also include the IFGTEP macro with several fields for mapping installation exit parameter lists. Values that can be returned are: EFMT1 and EFMT2 in TEPMRECTK recording technology, MEDIA5, MEDIA6, MEDIA7, MEDIA8, MEDIA9 and MEDIA10 in TEPMMEDT media type.

### Related reading:

- See *z/OS DFSMS Using Data Sets* and *z/OS DFSMS Using Magnetic Tapes* for additional information about the OCE routines.
- See *z/OS DFSMS Installation Exits* for more information on OCE installation exit parameter lists.
- See *z/OS DFSMS OAM Planning, Installation, and Storage Administration Guide for Tape Libraries* for more information on tape volume records.
- See Chapter 56, “OCE modifications for 3592 Model J,” on page 385 for more information on the existing WORM tape support.

---

## Overview

In a 3494 automated or manual tape library, and in a standalone environment, the new 3592 Model E05 tape drive is supported only in 3590-1 emulation mode. The 3592 Model E05 introduces a new enterprise format 2 (EFMT2) recording technology. This recording technology is a higher density format that nearly doubles the capacity of the existing EFMT1 3592 Model J1A. The 3592 Model E05 is downward read compatible with existing EFMT1 formatted media, and optionally can be explicitly directed to write from BOT in EFMT1 recording format. The drive appends away from load point using the volume's existing recording format (EFMT1 or EFMT2).

---

## SMS Managed Tape

Tape Volume Record (TVR) of SMS Managed cartridge is updated by OPEN and EOVS with the new underlying recording technology when TVR is opened for output to the first file (beginning of tape) on a 3592 Model E05 drive.

---

## Recording Technology Conflict

OPEN and EOV resolve the incompatible track conflict when an EFMT2 formatted cartridge is mounted on a lower technology 3592 Model J1A drive during OPEN OUTPUT file sequence 1. The loadpoint label structure is rewritten at the drive capable recording technology using the existing volume serial number that is obtained from the drive sense data.

---

## Dual Recording Capability

For both system managed and standalone environments, during OPEN OUTPUT, file sequence 1, DISP=NEW, OPEN retrieves DATACLASS to determine if the lower recording technology format EFMT1 is requested. For an EFMT1 request OPEN issues drive commands to enable EFMT1 recording technology from loadpoint. This function is supported only on media types from MEDIA5 to MEDIA8.

---

## Segmentation Format

A new performance segmentation option is available through data class policy definitions. Performance Segmentation divides the cartridge into a fast access segment and a slower access segment. The fast access segment is filled first, after which the slower segment is filled. Data class provides a filter criteria such as job name, application program name or dataset name to control whether a tape will be used for full capacity or performance segmentation. For both system managed and standalone environments, during OPEN OUTPUT file sequence 1, DISP=NEW OPEN retrieves DATACLASS to determine if Performance Segmentation is requested. Performance Segmentation is mutual exclusive with Performance Scaling. For a Performance Segmentation request OPEN issues drive commands that enable this option. During CLOSE OUTPUT for file sequence 1 on a performance segmented tape, performance segmentation is externalized in existing message iec205i:

```
IEC205I ddname,jobname,stepname,FILESEQ = nnn, COMPLETE VOLUME LIST |  
      EXTEND VOLUME LIST,[DSN=dsn], VOLS=volser, [TOTALBLOCKS=mmm], [3490  
      EMULATION VOLUMES EXTENDED CAPACITY MODE | 3490 EMULATION VOLUMES  
      EXTENDED CAPACITY USED], [PERFORMANCE SEGMENTED | PERFORMANCE SCALED]
```

OPEN OUTPUT either for MOD or EXTEND or for any type OPEN OUTPUT request to file sequence 1 or higher tracks the existing segmentation of the current volume. EOV OUTPUT processing then enforces this same segmentation across all volumes of a multivolume data set.

---

## Media Support

The 3592 model E05 supports two new media types.

### **MEDIA9**

IBM TotalStorage Enterprise Extended Cartridge

### **MEDIA10**

IBM TotalStorage Enterprise Extended WORM Cartridge.

The capacity of both MEDIA9 and MEDIA10 is 700 GB. OCE recognizes and passes these new media types to SMS, RMM and to the installation tape exits. OCE additionally calls SMS configuration services to obtain and enforce the dataclass policy definitions for the new media types during OPEN OUTPUT, file sequence 1, DISP=NEW.

For HDZ11G0, MEDIA9 and MEDIA10 are not supported. When either of these media types are mounted, OPEN/EOV will detect IEC147I 613-84 or IEC147I 637-84 respectively with RC84 (The mounted tape media type is not supported at the current system level).

---

## OCE Tape Installation Exits

The IFGTEP macro maps the tape log data. Table 47 describes the IFGTEP fields for mapping the installation exit main parameter list.

*Table 47. IFGTEP fields for the installation exit main parameter list*

Field name	Length or bit pattern	Description
Field name	Length or bit pattern	Description
TEPMRECTK	FIXED(8)	Recording technology of the mounted volume in binary.
TEPMMEDT	FIXED(8)	Media type of the mounted volume in binary.



---

## Chapter 46. DFSMSHsm modifications for 3592 Model E05

DFSMS hierarchical storage manager (DFSMSHsm), a z/OS functional component, automatically manages low activity and inactive data in both system-managed and non-system-managed environments. DFSMSHsm also provides automatic backup and recovery of active data in the same environments.

This topic describes specific changes to DFSMSHsm support for the new 3592 Model E05 tape drives. DFSMSHsm can use 3592 Model E05 for all functions. The 3592 Model E05 uses existing cartridge media (MEDIA5, MEDIA6, MEDIA7 and MEDIA8) and also supports two new media types: MEDIA9 (700 GB R/W) and MEDIA10 (700 GB WORM). MEDIA9 is available for all DFSMSHsm functions, while MEDIA10 is intended specifically for ABARS processing of ABACKUP tapes.

DFSMSHsm also adds support for enterprise format 2 (EFMT2), a new recording format that is required for using the new MEDIA9 and MEDIA10 cartridge media.

The changes are as follows:

- Planning and installation
- Input tape utilization
- Output tape selection
- Output tape utilization
- Reuse capacity table
- Displaying EFMT2 formatted volumes
- WORM tape cartridge rejection at OPEN time
- Aggregate backup and recovery (ABARS) with WORM tape cartridge

### Related reading:

- For more information on the LIST TTOC command, see *z/OS DFSMSHsm Implementation and Customization Guide*
- For more information on the SETSYS command, see *z/OS DFSMSdfp Storage Administration*.
- For more information about implementing DFSMSHsm tape environments, see *z/OS DFSMSdfp Storage Administration*.

---

## Planning and installation

In an HSMplex, coexisting systems without full support for 3592-E05 should apply the z/OS support PTFs without the enabling PTF. Doing so allows a coexisting system to reject partial tapes written by the 3592-E05 with EFMT2 technology.

---

## Input tape utilization

You can use MEDIA5, MEDIA7, and MEDIA9 tapes as input for all DFSMSHsm functions. Besides these media types, you can also use MEDIA6, MEDIA8, and MEDIA10 tapes for ABARS processing.

MEDIA5, MEDIA6, MEDIA7 and MEDIA8 tapes can be written in either of two recording formats: EFMT1 or EFMT2. The MEDIA9 and MEDIA10 tapes must be written in EFMT2 format.

---

## Output tape selection

DFSMSHsm selects 3592 Model E05 tape drives for output in SMS and non-SMS tape environments. DFSMSHsm performs all of its allocation requests through these standard dynamic allocation interfaces:

- **Non-SMS-managed output tape selection:** If multiple types of tape drives are installed that emulate the 3590 device type, you must define an esoteric name for each model that DFSMSHsm uses. You must then define the esoteric names to DFSMSHsm by using the SETSYS `USERUNITTABLE(esoteric1:esoteric1,esoteric2:esoteric2,...)` command. You must also specify the esoteric names as the unit names for the desired DFSMSHsm functions. If a single type of tape drive is installed that emulates the 3590 device type, or there is a mix of 3592 Model E05 and J1A drives and the E05 drives are set-up to use EFMT1, you do not have to define an esoteric name; instead, you can specify the 3590-1 generic name for the desired DFSMSHsm functions.
- **SMS-managed output tape selection:** DFSMSHsm performs a non-specific allocation; it then finds an acceptable output tape for the already allocated drive. If you use a 3590-1 generic that contains mixed devices, see APAR OW57282 for information about disabling the 3590-1 mixed device checking and the corresponding ARC0030I failure message.

---

## Output tape utilization

DFSMSHsm writes to 97% of the capacity of MEDIA5, MEDIA6, MEDIA7, MEDIA8, MEDIA9 and MEDIA10 tapes unless otherwise specified by the installation. Other percentages can be specified through the SETSYS `TAPEUTILIZATION` command, depending on the particular needs of the installation. DFSMSHsm uses the reported cartridge type on the physical device to determine the tape's capacity.

## Scratch tapes

The 3592-E05 can use empty MEDIA5, MEDIA7 or MEDIA9 tapes for all DFSMSHsm functions, and also use empty MEDIA6, MEDIA8, and MEDIA10 tapes for ABARS processing.

Because the 3592-E05 can write in either of two recording formats (EFMT1 or EFMT2) to MEDIA5, MEDIA6, MEDIA7 and MEDIA8 tapes, you must modify your installation's ACS routines to select the recording format to be used on blank media (through the data class assigned to the tape) if you want the 3592 Model E05 drives to use EFMT1.

For duplexed tapes, ensure that the data class selects the same media type and recording technology for the original and the alternate copy. Not doing so can result in failure when the duplex tape is mounted for output, or when using the alternate copy after a tape replace. If different media or machine types are needed for the original and alternate tapes, see APARs OW52309, OA04821 and OA11603 for more information.

## Partial tapes

When the 3592-E05 uses a MEDIA5, MEDIA6, MEDIA7 or MEDIA8 partial tape for output, the tape could have been written in either EFMT1 or EFMT2 recording technology. In contrast, MEDIA9 and 10 partial tapes are always recorded using



EFMT2 technology. DFSMSHsm automatically determines the format in which a tape is written and extends the tape in the same format.

---

## Reuse capacity table

The reuse capacity table supports MEDIA9 and MEDIA10 tape cartridges for 3592 Model E05 tape drives. DFSMSHsm uses the reuse capacity table to determine the tapes eligible for RECYCLE processing based on capacity for each media type. Each media type has separate reuse capacities for backup and migration (MEDIA10 is available only for ABARS processing of ABACKUP tapes).

---

## Displaying EFMT2 formatted volumes

You can use the LIST TTOC command to list volumes based on the recording technology used. To list all volumes recorded in EFMT1 format, enter the LIST TTOC command as follows:

```
LIST TTOC SELECT(EFMT1)
```

To list all volumes recorded in EFMT2 format, enter the LIST TTOC command as follows:

```
LIST TTOC SELECT(EFMT2)
```

---

## WORM tape cartridge rejection at OPEN time

DFSMSHsm examines the OEVSWORM field passed by OPEN/EOV processing. The bit is turned on by OPEN/EOV when a WORM tape cartridge has been mounted. If a WORM tape cartridge is mounted for any function other than ABACKUP or ARECOVER, DFSMSHsm returns to OPEN/EOV with RC08, resulting in ABEND913 RC34 and a failure of OPEN. DFSMSHsm fails the function and issues either message ARC0309I (for non-ABARs) or ARC6410E (for an ARECOVER ML2 tape).

---

## Aggregate backup and recovery (ABARs) with WORM tape cartridge

Output for LIST AGGREGATE(agname) has a field labeled WORM. If the version resides on WORM tape cartridge media, WORM=YES. If it does not reside on WORM tape cartridge media, WORM=NO.

---

## DFSMSHsm tips

Here are some tips you might find helpful when using DFSMSHsm with the 3592 Model E05 tape drives.

- In a non-SMS mixed tape hardware environment, where multiple types of tape hardware are used to emulate 3590 devices, it is recommended that you define unique esoterics for each type of tape hardware. This action is necessary to avoid mixing incompatible recording technologies. You can define an esoteric to DFSMSHsm through the SETSYS USERUNITTABLE command, for example:

```
SETSYS UUT(3592E05:3592E05 3590H:3590H)
```

With esoterics defined, you can then direct output to the desired set of drives through the SETSYS command, for example:

```
SETSYS BACKUP(TAPE(3592E05))
```

- If your installation has an excessive number of spanning data sets, consider specifying a larger value in the SETSYS TAPESPANSIZE command. A larger absolute value is needed to represent the same amount of unused capacity on a

percentage basis when the tape has a larger total capacity. For example, if you allow 2% of unused tape to avoid tape spanning for a 3590-Hxx device using enhanced media, specify a TAPESPANSIZE of 1200 MB. To allow 2% unused tape for a MEDIA5 tape on a 3592 Model E05 device (no performance scaling), specify a TAPESPANSIZE of 9999 MB. All size calculations for scaled tapes are based upon the scaled size and not the unscaled size.

- If the speed of data access on MEDIA5 or MEDIA9 tape is more important than full use of capacity, consider using performance scaling. Performance scaling uses 20% of the physical capacity on each tape and keeps all data sets closer together and closer to the initial tape load point. If you use performance scaling with the DFSMSHsm duplex function, be sure the original tape and the alternate tape both use performance scaling. Similarly make sure that Tapecopy input tapes and output tapes have the same performance scaling attributes.

**Note:** Performance scaling is not available on these tape cartridge media: MEDIA6, MEDIA7, MEDIA8, and MEDIA10.

- If your installation is using MEDIA5 tapes with performance scaling, consider using MEDIA7 tapes for high performance functions. The available MEDIA5 tapes could then be used to their full capacity.

Consider performance segmentation as a compromise solution. Performance segmentation increases the performance of data sets in the first twenty percent of the tape's capacity, but also uses the remaining capacity as a slower access segment. Average performance for the tape is increased at the expense of losing a percentage of the MEDIA5 or MEDIA9 overall tape capacity. (You cannot determine which data sets reside in which segment.)

DFSMSHsm recycle processing of 3592 Model E05 tapes can take significantly longer than with smaller tapes because the amount of data moved at the same RECYCLEPERCENT can be much larger. Besides moving more data, the likelihood of a tape takeaway for recall processing increases with the number of data sets still remaining on the tape.

One option for controlling overall recycle run time is the LIMIT(*nnnn*) parameter of recycle. Recycle returns no more than the specified number of tapes to scratch during the current recycle run. Because recycle sorts the tapes based on the amount of valid data still on each volume, the tapes recycled require the least processing time.

Another option to consider is decreasing the ML2RECYCLEPERCENT parameter, the RECYCLEPERCENT parameter, or both. Assume, for example, that your installation uses MEDIA7 tape for ML2 and MEDIA5 tape for backup. If the EFMT1 format is used and you would like no more than 6 GB of data to be moved when an ML2 tape is recycled, set ML2RECYCLEPERCENT(10) because the MEDIA7 can hold 60 GB of data in EFMT1. If your installation uses full capacity for backup tapes and you want no more than 6 GB of data to be moved when a backup tape is recycled, set RECYCLEPERCENT(2) because a MEDIA5 tape can hold 300 GB of data in EFMT1. These examples assume that the ML2 and backup tapes in the installation are filled to capacity because the calculations are based upon the average fullness of marked full tapes on your system (the reuse capacity.)

To determine how much data your current recycle threshold implies, use the reuse capacity associated with the tapes. The current recycle threshold percent multiplied by the reuse capacity gives the maximum amount of data on any of the tapes when they are recycled.

While lowering the recycle threshold reduces recycle processing time and decreases the number of times each tape must be recycled, it may also increase the overall number of tapes needed in your installation. Also, if you have a mix

of ML2 or backup tape capacities in need of recycle processing, you may want to recycle tapes with the RANGE parameter and use the appropriate recycle threshold for the tape capacities in the range.

In an SMS tape environment, and optionally in a non-SMS tape environment, the SMS data class construct can be used to select WORM tapes for ABACKUP processing. The output data set prefix specified in the aggregate group definition can be used by the ACS routines to select a WORM data class. Set up the ACS routine and the output data set name to uniquely identify the ABARS output files that must go to WORM tape.

In a non-SMS tape environment, the default is to allow tape pooling to determine if ABARS data sets go to WORM or R/W media. Optionally, if the DEVSUP parameter ENFORCE\_DC\_MEDIA=ALLMEDIATY or ENFORCE\_DC\_MEDIA=MEDIA5PLUS is used, the data class must request the appropriate media type for it to be successfully mounted.

- Consider using the Fast Subsequent Migration function to reduce the need to RECYCLE these high-capacity tapes.
- For a Sysplex environment, consider using the Common Recall Queue to optimize mounts of migration tapes.
- AUDIT MEDIACONTROLS for a FAILEDCREATE situation usually only needs to look at the last few files on a tape. If it is available for your system level, make sure Audit APAR OA04419 is applied.
- The 3592 Model E05 tape drive is used in 3590 emulation mode only; never 3490. The 3592 Model J1A can operate in 3490 emulation mode only when using MEDIA5 for output.



---

## Chapter 47. DFSMSrmm modifications for 3592 Model E05

DFSMSrmm is a feature of z/OS. It manages all tape media, such as cartridge system tapes and 3420 reels, and other removable media that you define to it.

DFSMSrmm performs these functions to support the 3592 Model E05 tape drives:

- Records the recording technology, as appropriate
- Records the media type
- Manages WORM tapes

This topic describes the updates to these DFSMSrmm TSO subcommands:

- ADDVOLUME
- CHANGEVOLUME
- SEARCHVOLUME

It also lists the changed REXX variables of the TSO subcommand, API structured field introducers, and mapping macros fields.

### Related reading:

- See *z/OS DFSMSrmm Managing and Using Removable Media* for the complete syntax of the DFSMSrmm ADDVOLUME subcommand, the DFSMSrmm CHANGEVOLUME subcommand, the DFSMSrmm SEARCHVOLUME subcommand, DFSMSrmm return codes and reason codes, and REXX variables.
- See *z/OS DFSMSrmm Application Programming Interface* for further information about the DFSMSrmm API.
- See *z/OS DFSMSrmm Implementation and Customization Guide* and *z/OS DFSMSrmm Reporting* for additional information about DFSMSrmm mapping macros.

## ADDVOLUME

The ADDVOLUME TSO subcommand adds volumes to the DFSMSrmm control data set. This diagram shows the syntax of the MEDIATYPE operand and the RECORDINGFORMAT operand for the ADDVOLUME TSO subcommand.

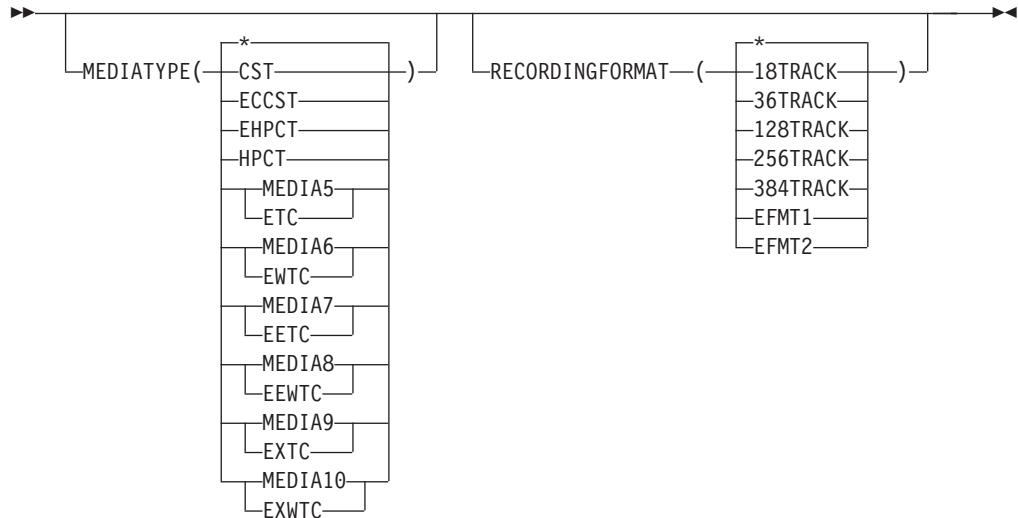

To use the EFMT2 recording technology, you must specify the MEDIATYPE(MEDIA5, MEDIA6, MEDIA7, MEDIA8, MEDIA9, or MEDIA10) operand of the ADDVOLUME TSO subcommand.

**Note:** DFSMSrmm uses its own media names for MEDIA1 through MEDIA4 and optionally uses its own media names for MEDIA5 through MEDIA10. DFSMSrmm uses these names in output for RMM LISTVOLUME subcommand requests and from any REXX EXECs you might have written. Table 48 lists these DFSMSrmm media names.

Table 48. DFSMSrmm media names

Media name	DFSMSrmm media name
MEDIA1	CST
MEDIA2	ECCST
MEDIA3	HPCT
MEDIA4	EHPCT
MEDIA5	ETC
MEDIA6	EWTC
MEDIA7	EETC
MEDIA8	EEWTC
MEDIA9	EXTC
MEDIA10	EXWTC

---

## CHANGEVOLUME

The CHANGEVOLUME TSO subcommand updates details for a volume defined to DFSMSrmm. This diagram shows the syntax of the MEDIATYPE operand and the RECORDINGFORMAT operand for the CHANGEVOLUME TSO subcommand.

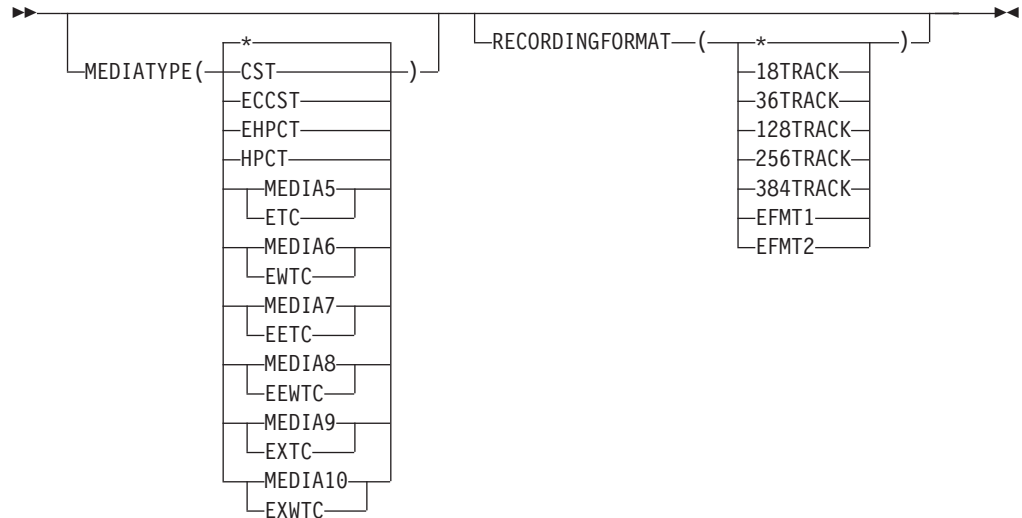

To use the EFMT2 recording technology, you must specify the MEDIATYPE(MEDIA5, MEDIA6, MEDIA7, MEDIA8, MEDIA9, or MEDIA10) operand of the CHANGEVOLUME TSO subcommand.

---

## SEARCHVOLUME

You can use the SEARCHVOLUME TSO subcommand to obtain a list of volumes that match selection criteria that you specify. Specify EFMT2 to limit your search to volumes that are written in the EFMT2 recording technology. You can also specify a particular media type, such as MEDIA9, to then further limit your search. This diagram shows the syntax of the MEDIATYPE operand and the RECORDINGFORMAT operand for the SEARCHVOLUME TSO subcommand.

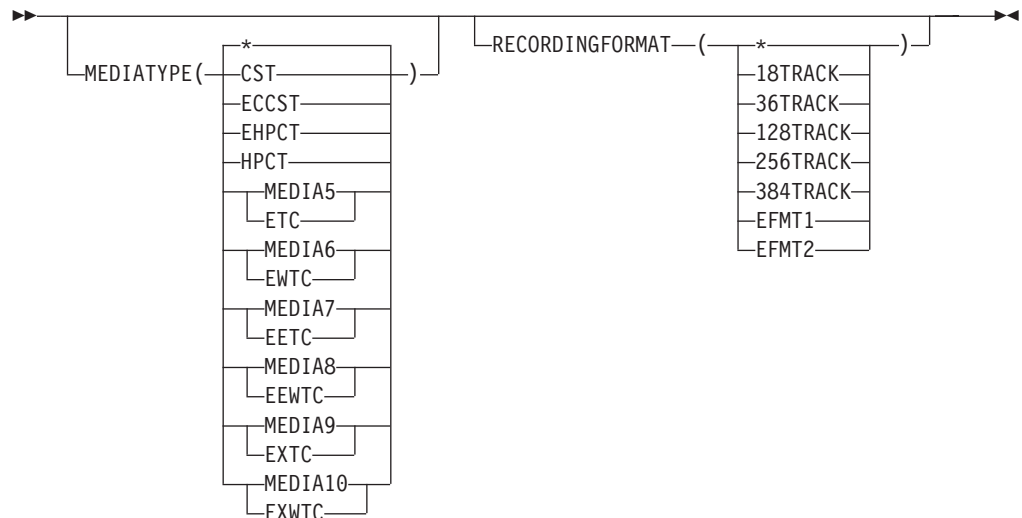

---

## DFSMSrmm REXX variables

You can use the REXX variables to obtain volume information. The variables produced by the SEARCHVOLUME subcommand are stem variables.

Table 49. Changed TSO subcommand REXX variables

Variable name	Subcommands	Contents	Format
EDG@MEDR	LV SV	Recording technology	One of *, NON-CARTRIDGE, 18TRK, 36TRK, 128TRK, 256TRK, 384TRK, EFMT1, and EFMT2
EDG@MEDT	LV SV	Tape media type	One of *, CST, ECCST, EHPCT, HPCT, ETC, EWTC, EETC, EEWTC, EXTC, and EXWTC

---

## DFSMSrmm structured field introducers

The DFSMSrmm application programming interface (API) returns data as structured fields in an output buffer that you define. Structured fields consist of a structured field introducer (SFI) and the data. SFIs describe the type, length, and other characteristics of the data.

Table 50 shows the structured field introducers that support 3592 Model E05 tape drives.

Table 50. Changed structured field introducers

Name	Number	Type	Length	Value	Subcommands
MEDR	X'857000'	Binary(8)	9	Media type: 0=NON-CARTRIDGE 1=18TRK 2=36TRK 3=128TRK 4=256TRK 5=384TRK 6=EFMT1 7=EFMT2	LV, SV
MEDT	X'858000'	Binary(8)	9	Media type: 0=UNDEFINED 1=CST 2=ECCST 3=HPCT 4=EHPCT 5=ETC/MEDIA5 6=EWTC/MEDIA6 7=EETC/MEDIA7 8=EEWTC/MEDIA8 9=EXTC/MEDIA9 10=EXWTC/MEDIA10	LV, SV

---

## DFSMSrmm macros

Table 51 shows the changes made to DFSMSrmm mapping macros for 3592 Model E05 tape drives.

Table 51. DFSMSrmm mapping macro changes

Mapping macro	Function	Updates
EDGEXTSY	Maps the extract data set symbols used with DFSORT.	Media type values: ETC, EWTC, EETC, EEWTC, EXTC, EXWTC, and recording technology values: EFMT1, EFMT2.
EDGRVEXT	Maps the volume records in the DFSMSrmm extract data set.	Media type values: ETC, EWTC, EETC, EEWTC, EXTC, EXWTC, and recording technology values: EFMT1, EFMT2.



Table 51. DFSMSrmm mapping macro changes (continued)

Mapping macro	Function	Updates
EDGRXEXT	Maps the data set records in the DFSMSrmm extract data set.	Media type values: ETC, EWTC, EETC, EEWTC, EXTC, EXWTC, and recording technology values: EFMT1, EFMT2.
EDGSMFSY	Maps the SMF record symbols used with DFSORT.	Media type values: ETC, EWTC, EETC, EEWTC, EXTC, EXWTC, and recording technology values: EFMT1, EFMT2.
EDGSVREC	Maps the DFSMSrmm SMF volume records.	Media type values: ETC, EWTC, EETC, EEWTC, EXTC, EXWTC, and recording technology values: EFMT1, EFMT2.
EDGCLREC	Maps the data set records in the DFSMSrmm extract data set.	Media type values: ETC, EWTC, EETC, EEWTC, EXTC, EXWTC, and recording technology values: EFMT1, EFMT2.
EDGPL100	Maps the DFSMSrmm installation exit, EDGUX100, parameter list.	Fields PL100_TDSI1 and PL100_TDSI2 are renamed by adding _OLD to the names. Use PL100_TDSI field instead.

## Volume Not in Library Support

In the past, for all calls to the CBRUXVNL exit, the supplied sample code linked to EDGLCSUX to retrieve the DFSMSrmm information for the volume. Now, calls to EDGLCSUX can be made only when it is determined that the request is for a tape volume. However, exit customization may be required in order to get complete benefit from this new support. The new input fields in CBRUXNPL are used during the job setup call to the exit to make an informed decision. The decision is added to CBRUXVNL and is partly selectable via conditional assembly to enable easy customization by you. An informed decision can be made when catalog information is available that confirms whether a volume is a tape or not. By default, the initial call to EDGLCSUX is made in these cases:

- Job information is unavailable.
- Catalog information is available, and the device type is a tape device. When catalog information is available, but the device type is not tape, the exit skips the link to EDGLCSUX.

DFSMSrmm provides the possibility to further enhance the EDGLCSUX calls by providing an option to compare the JCL esoteric unit name against a list of your known tape unit names. You can enable this additional option by customizing the default processing by:

- Turning on the tape unit name checking code by changing the setting &TAPEDEC SETC to 'YES', and
- Customizing the hardcoded list of tape unit names. The tape unit names are listed in the shipped table called TAPEUNITS. Ensure that you include in this table all the tape unit names your users code in their JCL. You can include esoteric, generic, and specific unit names. The default table is also shown.

```

TAPEUNITS DC  A(TAPFIRST,8,TAPLAST)
*****
* Tape units list - may be customized
*****
TAPFIRST DC   CL8'TAPE'
* insert your location tape unit names here
* or edit any entry
   DC   CL8'3400-6'
   DC   CL8'3420-8'
   DC   CL8'CART'
   DC   CL8'3480'
   DC   CL8'3480X'
   DC   CL8'3490'
   DC   CL8'3490E'
   DC   CL8'3590'
   DC   CL8'3590-1'
   DC   CL8'3590-E'
   DC   CL8'3590-B'
   DC   CL8'3590-H'
   DC   CL8'3590L'
   DC   CL8'3592'
   DC   CL8'3592-J'
   DC   CL8'SYS3480R'
   DC   CL8'SYS348XR'
   DC   CL8'VTS'
   DC   CL8'MTL'
   DC   CL8' '    any blank entry is ignored
TAPLAST DC   CL8'ATL'

```

Figure 27. Contents of the shipped table: TAPEUNITS

When you have &TAPEDEC set to 'YES', CBRUXVNL checks the supplied unit name and calls EDGLCSUX only in the case where it matches some tape unit name within the TAPEUNITS table. Otherwise, the EDGLCSUX call is skipped.

In addition, the decision to issue message EDG8197I for non-RMM managed volumes is made selectable via an option flag in the EDGLCSUP parameter list. The CBRUXVNL exit shipped by DFSMSrmm sets this option flag ON when the device type supplied by catalog is a tape device or &TAPEDEC is set to 'YES'. Otherwise, this option flag is OFF. To change this decision, you can customize the CBRUXVNL source code. This ensures that you will see message EDG8197I when you believe the volume is a tape volume, and the tape volume is not managed by DFSMSrmm.

---

## Chapter 48. EREP modifications for 3592 Model E05

Environmental Recording, Editing, and Printing (EREP) program is a diagnostic application program that runs under MVS, VM, and VSE. It generates and prints reports from error recording data set (ERDS) records. With these reports, IBM service representatives can determine the existence, nature, and location of a problem.

This topic describes changes to the tape subsystem exception, event history, system error summary, and emulated device summary reports of the EREP program to support 3592 Model E05 tape drives.

---

### Tape subsystem exception report

As shown in Figure 28, EREP reports a temporary ORB record in its tape subsystem exception report in support of 3592 Model E05 tape drives.

TAPE SUBSYSTEM EXCEPTION REPORT				REPORT DATE 220 05			
				PERIOD FROM 076 02			
				TO 077 02			
*** SEQUENCE BY PROBABLE FAILING UNIT ***							
PROBABLE FAILING UNIT	DEVICE TYPE/ VALID	FAILURE AFFECT	CPU	DEVNO /CUA	SIMS	MIMS	ORR PERM OBR TEMP
*****							
LIBRARY				TOTAL	0	0	0 1
	3570-CXX	LIBRARY INFORMATIONAL DATA	00	07C2	0	0	0 1
DEVICE				TOTAL	0	0	2 1
	3590-H1X	LIBRARY DRIVE NOT UNLOADED	02	0C24	0	0	1 0
	3592-J1X	WORM OVERWRITE REJECTED	03	0C27	0	0	0 1
	3592-E05	LIBRARY DRIVE NOT UNLOADED	00	1B90	0	0	0 1
	3592-E05	PREVENTIVE MAINTENANCE COMPLETED	00	07C2	1	0	0 0

Figure 28. Partial tape subsystem exception report

---

### Event history report

As shown in Figure 29 on page 324, EREP reports 3590 as the native device type in its event history report in support of 3592 Model E05 tape drives.

EVENT HISTORY (S/370 & S/370XA)

TIME	JOBNAME	RECTYP	CP	CUA	SSYS	DEVT
DATE			*	DNO	CRW	
02 15 34 50	N/A	MDR	01	04B2	3590	04
02 22 35 74	N/A	MDR	00	04B0	3590	04
10 02 06 17	DRVNDSA	OBRTMP	03	0591	3590	
10 02 10 78	DRVNDSA	OBRPRM	03	0591	3590	
12 54 45 51	VARY	OBRPRM	06	0563	3590	06
23 08 25 93	DISB/RGP	OBRTMP	00	04BA	3590	04
23 08 25 93	DISB/RGP	OBRPRM	00	04BA	3590	
23 08 25 93	DISB/RGP	OBRTMP	00	04BE	3590	16

Figure 29. Partial event history report

## System error summary report

Figure 30 illustrates that the EREP system error summary report is changed to support 3592 Model E05 tape drives. The system error summary for 3590 includes the system error summary report series for 3590. These reports are only shown for 3592-E05 devices that emulate 3590 devices.

SYSTEM ERROR SUMMARY (PART 2)

REPORT DATE 054 99  
 PERIOD FROM 044 98  
 TO 022 02

TIME	JOBNAME	CPU	PHYSICAL ID	PHYSICAL TYPE	PHYSICAL ADDRESS	ERROR PATH	ERROR VOLUME	ERROR DESC	PROBABLE FAILING
DATE	358/99								
10:02:10:78	DRVNDSA	02	N/A	3590	0591	0591		N/A	HARDWARE
23:08:25:93	DISB/RGP	00	N/A	3590	04BA	16-04BA		N/A	VOLUME/C

Figure 30. Partial system error summary report

## Emulated device summary report

Figure 31 on page 325 provides an example of an EREP emulated device summary report. The report in this example shows the emulated device type for 3592 Model E05 tape drives. The report includes an example of a 3592-E05 emulating a 3590-B1X.

3590 DEVICE SUMMARY

REPORT DATE 220 05  
PERIOD FROM 076 02  
TO 077 02

DEVICE ADDRESS	REAL / EMULATED DEVICE TYPE
014C	3590-E1X / 3490-CXX
014D	3590-B1X / 3490-CXX
014E	3590-E1X / 3490-CXX
0231	3590-H1X / 3490-CXX
0232	3590-H1X / 3490-CXX
0233	3590-H1X / 3490-CXX
0234	3592-J1X / 3490-CXX
04B8	3590-B1X / 3490-CXX
04B9	3590-B1X / 3490-CXX
04BA	3590-B1X / 3490-CXX
04BB	3590-B1X / 3490-CXX
04BC	3590-B1X / 3490-CXX
0591	3590-E1X / 3490-CXX
0592	3590-E1X / 3490-CXX
0880	3590-XXX / NATIVE
0881	3590-XXX / NATIVE
0882	3590-XXX / NATIVE
0883	3590-XXX / NATIVE
0884	3590-XXX / NATIVE
088A	3590-XXX / NATIVE
08AA	3590-E1X / 3590-B1X
08AB	3590-E1X / 3590-B1X
08AC	3592-E05 / 3590-B1X
08AC	3592-J1X / 3590-B1X

Figure 31. Partial emulated device summary report



---

## Chapter 49. JES3 modifications for 3592 Model E05

JES3, a z/OS MVS subsystem, manages resources and work flow before and after jobs are processed. You can enable JES3 to allocate 3592 Model E05 tape drives and tape volumes in an SMS-managed IBM tape library environment (automated or manual) for 3590 Model B emulation only. To do so, you need to specify at least one of these library device group (LDG) names in your JES3plex. An LDG is a predefined set of tape subsystems within a JES3plex.

### **LDKsssss**

Includes any 3592 Model E05 device emulating a 3590 Model B within the library indicated by serial number sssss.

### **LDGdddd**

Includes any D/T3592 Model E05 device emulating a D/T3590 Model B in any library in the JES3plex. dddd = 359K.

See *z/OS JES3 Initialization and Tuning Reference* for additional information on LDGs, JES3, and JES3plex.





---

## Chapter 50. OAM modifications for 3592 Model E05

The Object Access Method (OAM) is a component of DFSMSdftp. OAM uses the concepts of system-managed storage, introduced by SMS, to manage, maintain, and verify tape volumes and tape libraries within a tape storage environment. You can also use OAM's object support to manage objects on DASD, tape, and optical volumes.

### Related reading:

- See *z/OS DFSMS OAM Planning, Installation, and Storage Administration Guide for Tape Libraries* for additional information about using OAM to manage tape volumes and tape libraries.
- See *z/OS DFSMS OAM Planning, Installation, and Storage Administration Guide for Object Support* for additional information about using OAM to manage the data on tape volumes.
- See *z/OS MVS System Messages, Vol 4 (CBD-DMO)* for explanations and appropriate actions for CBRxxxxx messages.

---

## OAM library support

OAM uses the concepts of system-managed storage, introduced by SMS, to manage, maintain, and verify tape volumes and tape libraries within a tape storage environment. This topic describes the OAM library support functions that have been changed for use with the 3592 Model E05 tape drives. The enhancements include support for a new recording format EFMT2 and support for two additional 3592 media types MEDIA9 and MEDIA10. Note that the new media types are only supported on z/OS V1R5 and above whereas the drive itself is supported on z/OS V1R4 and above. This topic also describes enhancements to the volume not in library installation exit (CBRUXVNL) to pass additional job-related information.

## LCS external services changes

LCS External Services supports the applicable 3592 Model E05 media types, MEDIA5, MEDIA6, MEDIA7, MEDIA8, MEDIA9, and MEDIA10, and the recording technology, EFMT1 and EFMT2, for these functions:

- Change use attribute
- Query volume residence
- Test volume eligibility
- Eject a volume
- Manual cartridge entry

### Note:

- The MEDIA5, MEDIA6, MEDIA7, and MEDIA8 media types are valid with the EFMT1 or EFMT2 recording technologies.
- The MEDIA9 and MEDIA10 media types are valid only with the EFMT2 recording technology.

## OAM installation exits changes

These installation exits support the new EFMT2 recording technology, and new MEDIA9 and MEDIA10 media types:

- Change use attribute (CBRUXCUA) installation exit: Tape recording technology fields and media type fields have been updated with EFMT2, MEDIA9, and MEDIA10.
- The UXCVWORM indicator is set to on for MEDIA10 to indicate this is a WORM volume as was done with previous WORM media types. The tape management system is alerted that the CUA function is being performed for a WORM volume when invoking the CBRUXCUA installation exit.
- Cartridge entry (CBRUXENT) installation exit: Tape recording technology fields and media type fields have been updated with EFMT2, MEDIA9, and MEDIA10.
- Cartridge eject (CBRUXEJC) installation exit: Tape recording technology fields and media type fields have been updated with EFMT2, MEDIA9, and MEDIA10.
- Volume not in library (CBRUXVNL) installation exit: Tape recording technology fields and media type fields have been updated with EFMT2, MEDIA9, and MEDIA10. For additional changes to the exit, refer to “Volume not in library installation exit enhancement” on page 332.

## Operator command support changes

Volumes with EFMT2 recording technology are only displayed on systems with full 3592 Model E05 support installed. MEDIA9 and MEDIA10 volumes are only displayed on z/OS V1R5 or above systems with full 3592 Model E05 support installed.

These operator tasks have been changed in support of the 3592 Model E05 tape drives.

- When appropriate, the DISPLAY SMS,VOLUME command can now display the new EFMT2 recording technology, and the new MEDIA9/MEDIA10 media types, in the output display for CBR1180I (OAM tape volume status).
- The LIBRARY DISPDRV command displays 3592-2 for the 3592 Model E05 tape drives in the output display for CBR1220I (Tape drive status). MEDIA9 or MEDIA10 is displayed as appropriate in this display.
- The LIBRARY ENTER command allows MEDIA9 or MEDIA10 to be set when entering the new media types into a manual tape library.
- The DISPLAY SMS,LIBRARY(library-name),DETAIL command displays MEDIA9 and MEDIA10 scratch counts, scratch thresholds, and scratch categories in the output display for CBR1110I.
- The LIBRARY DISABLE command allows CBRUXVNL to be specified, disabling the volume not in library exit.

**Note:** This does not disable job processing but does result in the volume not in library installation exit being bypassed or not called. In the absence of the CBRUXVNL installation exit's intervention, Job Step Setup processing attempts to allocate an applicable stand-alone tape drive for a volume that has been inadvertently ejected from a tape library. If there is no stand-alone drive capable of handling the tape volume request, the job or dynamic allocation fails. During Device Allocation or during Library Mount Processing, normal job processing for a volume not in the library with no CBRUXVNL installation exit intervention results in the job step or dynamic allocation failing.

- The DISPLAY SMS,OAM command, which already includes the status of the CBRUXVNL exit, displays OPERATOR DISABLED for the VNL exit, if appropriate.
- The LIBRARY SETCL command now allows MEDIA9 or MEDIA10 to be set for a 3592 Model E05 device that supports a cartridge loader.

## Scratch mount considerations

Beginning with V1R5, a scratch request with no media type specified, and a 3592 Model E05 drive is allocated, if EFMT2 or no recording technology is specified, there are now 3 applicable scratch categories (MEDIA9, MEDIA5, and MEDIA7). Otherwise, there are two applicable media types for the 3592 Model E05 (MEDIA5 and MEDIA7).

As with existing WORM media types (MEDIA6 and MEDIA8), WORM media is not mounted by default and must be explicitly requested through Dataclass (this includes MEDIA10).

## Scratch threshold processing change

For a scratch mount request with no media type specified, WORM media types are no longer included in the criteria to determine whether a library is above threshold as WORM media types must be specifically requested by data class.

## OAM macro changes

Table 52 describes changes to OAM mapping macros and installation exit parameter lists in support of 3592 Model E05 tape drives.

Table 52. OAM mapping macro changes

The macro	that maps	has these changes.
CBRTDSI	the tape device selection information (TDSI)	TDSEFMT2 EQU 7 READ/WRITE on ENTERPRISE FORMAT 2 (EFMT2) DEVICE TDSMED9 EQU 9 MEDIA9 - ENTERPRISE EXTENDED TAPE CARTRIDGE TDSMED10 EQU 10 MEDIA10 - ENTERPRISE EXTENDED WORM TAPE CARTRIDGE
CBRTVI	the tape volume information	TVIEFMT2 EQU 7 READ/WRITE on ENTERPRISE FORMAT 2 (EFMT2) DEVICE TVIMED9 EQU 9 MEDIA9 - ENTERPRISE EXTENDED TAPE CARTRIDGE TVIMED10 EQU 10 MEDIA10 - ENTERPRISE EXTENDED WORM TAPE CARTRIDGE TVISCRM9 EQU C'S9' Volume is MEDIA9 SCRATCH TVISCRMA EQU C'SA' Volume is MEDIA10 SCRATCH TVIMEDTY has a new value for MEDIA9 which is X'09' TVIMEDTY has a new value for MEDIA10 which is X'0A'
CBRUXCPL	the change use attribute installation exit parameter list	UXCEFMT2 EQU 7 READ/WRITE on ENTERPRISE FORMAT 2 (EFMT2) DEVICE UXCMED9 EQU 9 MEDIA9 - ENTERPRISE EXTENDED TAPE CARTRIDGE UXCMED10 EQU 10 MEDIA10 - ENTERPRISE EXTENDED WORM TAPE CARTRIDGE
CBRUXEPL	the cartridge entry installation exit parameter list	UXEEFMT2 EQU 7 READ/WRITE on ENTERPRISE FORMAT 2 (EFMT2) DEVICE UXEMED9 EQU 9 MEDIA9 - ENTERPRISE EXTENDED TAPE CARTRIDGE UXEMED10 EQU 10 MEDIA10 - ENTERPRISE EXTENDED WORM TAPE CARTRIDGE

Table 52. OAM mapping macro changes (continued)

The macro	that maps	has these changes.
CBRUXJPL	the cartridge eject installation exit parameter list	UXJEFMT2 EQU 7 READ/WRITE on ENTERPRISE FORMAT 2 (EFMT2) DEVICE UXJMED9 EQU 9 MEDIA9 - ENTERPRISE EXTENDED TAPE CARTRIDGE UXJMED10 EQU 10 MEDIA10 - ENTERPRISE EXTENDED WORM TAPE CARTRIDGE
CBRUXNPL	the volume not in library installation exit parameter list	UXNEFMT2 EQU 7 READ/WRITE on ENTERPRISE FORMAT 2 (EFMT2) DEVICE UXNMED9 EQU 9 MEDIA9 - ENTERPRISE EXTENDED TAPE CARTRIDGE UXNMED10 EQU 10 MEDIA10 - ENTERPRISE EXTENDED WORM TAPE CARTRIDGE  The CBRUXVNL installation exit is enhanced with these new job-related information fields:  UXNSUPPT DS   XL1           SUPPORT FLAGS UXNJINFO EQU  X'80'       ON IF JOB INFORMATION PROVIDED *                            (JOB STEP SETUP INVOCATION)  UXNJOB   DS    0CL120       JOB INFORMATION UXNJOBNM DS   CL8           JOB NAME UXNSTPNM DS   CL8           STEP NAME UXNPRGNM DS   CL8           PROGRAM NAME UXNDDNM  DS   CL8           DD NAME UXNDSN   DS   CL44          DATASET NAME UXNUNIT  DS   CL8           UNIT NAME UXNDISP  DS   0CL17       DISPOSITION (DISP=...) UXNDISP1 DS   CL3           1ST SUBPARAMETER, STATUS UXNDISP2 DS   CL7           2ND SUBPARAMETER, NORMAL UXNDISP3 DS   CL7           3RD SUBPARAMETER, ABNORMAL * UXNFLAGS DS   XL1           JOB INFORMATION FLAGS UXNCATLG EQU  X'80'       ON IF VOLSER OBTAINED FROM CATALOG DS   CL2           RESERVED UXNDEVTP DS   CL4           DEVICE TYPE FROM CATALOG *                            (PROVIDED IF UXNCATLG IS ON)

## Volume not in library installation exit enhancement

The volume not in library installation exit (CBRUXVNL) receives control under a variety of circumstances and error conditions that occur during job processing. The primary purpose of the exit is to give the installation the opportunity to enter a volume into a tape library during job step setup, device allocation and library mount processing.

If a tape is inadvertently ejected from a tape library, the exit is invoked providing an opportunity to reenter the volume in the library. With this support, job-related information is passed to the exit, via the CBRUXNPL parameter list, increasing the length of the parameter list. Job-related information can be used to assist the exit in making better decisions on whether to enter the volume in a library or take other action such as cancel the job or allow the allocation to select a standalone drive. The UXNJINFO indicator in the CBRUXNPL parameter list is set on when the CBRUXVNL installation exit is invoked during job step setup processing and job information is provided in the UXNJOB job information fields. If the UXNJINFO indicator is not on, then either the job information is not available because the CBRUXVNL exit invocation is not for job step setup processing or the system does not have the volume not in library job information support installed. If job

information is available (job step setup CBRUXVNL invocation) but the information for a job information field is not available, the field contains binary zeroes. The new job-related information is only passed to the volume not in library exit during the job step setup invocation as this is the critical time for the exit to determine if the volume should be entered into a library. For the other phases of processing (device allocation and library mount processing), it has already been determined that the volume should reside in a tape library and timing was such that the volume was ejected. Since a failure to enter the volume into a tape library or the library specified during the device allocation or library mount phases of processing would result in job failures, the additional job-related information is not needed for those phases of processing.

If UXNJOB job information is available (job step setup CBRUXVNL invocation) but the information for a job information field is not available, generally, the field contains binary zeroes. The UXNDISP fields contain standard JCL disposition parameters (status, normal, abnormal), reflecting the job specifications. If not specified on the job invocation, UXNDISP1, UXNDISP2, and UXNDISP3 may contain zeroes or, in some cases, may contain default disposition settings rather than zeroes. If the CBRUXVNL installation exit is invoked and the job-related information is for a volume that is part of a concatenated data set DD statement and is not the first data set in the concatenation, the UXNDDNM field will contain blanks.

For old allocations, if a volser was not specified and the dataset is cataloged, then the UXNCATLG indicator is set "on" and the UXNDEVTP field contains the 4-byte device type from the catalog. Otherwise, the UXNCATLG indicator is "off" and the UXNDEVTP field contains zeroes. When unit information is available (UNIT=), the UXNUNIT field contains the passed value; otherwise, the UXNUNIT field contains zeroes.

For more information regarding the CBRUXVNL installation exit, please see *z/OS DFSMS OAM Planning, Installation, and Storage Administration Guide for Tape Libraries*.

## Cartridge entry processing

When a volume is entered into an IBM automated or manual tape library, the cartridge entry installation exit (CBRUXENT) is invoked to approve or deny an enter request and to set or verify the recording technology to be associated with a volume. If a volume TCDB record does not exist for the entry of a private MEDIA5, MEDIA6, MEDIA7 or MEDIA8 volume and there is no applicable recording technology being provided by the library's entry default data class, EFMT1 is passed to the exit; unknown is passed for a scratch volume.

If the exit returns with a recording technology for a MEDIA5, MEDIA6, MEDIA7, or MEDIA8 volume and it is not EFMT1 or EFMT2, the specification is considered invalid and the exit is disabled.

For a MEDIA9 or MEDIA10 volume, EFMT2 is passed to the exit as this is the only applicable recording technology for these media types; any other specification is considered invalid and the exit is disabled.

If a TCDB volume record exists and the volume's recording technology or media type is not supported on the system processing the volume, in an ATLDS, the volume is left in the library manager insert category to be processed by a system with appropriate support.

If CBRXLCS FUNC=MCE is used to enter a volume into an MTL and its existing TCDB record has EFMT2 recording technology or an unsupported media type (MEDIA9/MEDIA10) and the software does not support the recording technology and/or the media type, the request is failed with existing return code LCSFAIL (12) and existing reason code LCSFNSUP (310). If the CBRUXENT exit returns a recording technology or media type not supported in the MTL(up-level recording technology), the entry of the volume also fails.

## **Tape device selection information (TDSI) Migration Considerations**

In prior support when new devices were introduced, there were read-compatibility considerations that required the customer to indicate on a volume or job basis that the request for a volume was for read-only purposes. This enabled a higher technology device that was downward read-compatible to be considered eligible for the request. This was particularly important if a customer had upgraded all of the drives in the library to the new recording technology and was a way to indicate that the volume was going to be used for read-only purposes. Since the 3592 Model E05 is both downward read and write compatible, explicit specification of the read-compatible special attribute indicator (TDSSPEC) or usage of the LABEL=(,,,IN) on the DD statement of JCL will not be required for the EFMT1 recording format.

---

## **OAM object tape support**

The Object Access Method (OAM) is also an access method supporting a class of data referred to as objects. An object is a named stream of bytes. The content, format, and structure of that byte stream are unknown to OAM. There are no restrictions on the data in an object. For example, an object can be a compressed scanned image or coded data. Objects are different from data sets handled by existing access methods.

In an IBM tape library environment, the SETOAM DATACLASS parameter can be specified using a data class that contains the media type or recording technology; these specifications are associated with an Object or Object Backup storage group in the CBROAM $xx$  member of PARMLIB.

In a stand-alone environment, the SETOAM TAPEUNITNAME parameter can be specified using an esoteric that contains 3592 Model E05. In addition to this, the SETOAM DATACLASS parameter can be used to indicate that the lower recording format (EFMT1) should be used by the drive, otherwise the default recording format (EFMT2) is used when writing from load point. These specifications are associated with an Object or Object Backup storage group in the CBROAM $xx$  member of PARMLIB.

In addition, the SETOAM DATACLASS parameter can also be used inside and outside an IBM tape library environment to take advantage of performance scaling and performance segmentation. Performance scaling and performance segmentation are only available with MEDIA5 or MEDIA9 tape cartridge media. A DATACLASS with the performance scaling or performance segmentation data class attribute selected can be specified for OBJECT storage groups. The performance scaling data class attribute can be used to improve the random retrieval rate of primary objects; whereas, objects written to OBJECT BACKUP storage groups can specify a DATACLASS that does not specify performance scaling and can continue

to utilize the full capacity of the MEDIA5 or MEDIA9 volume. For more detail on performance scaling and performance segmentation, see "Performance scaling and segmentation for 3592" on page 264.

In addition to the performance scaling option available with MEDIA5 and MEDIA9 cartridge, the 60GB MEDIA7 economy cartridge can also be used to improve the random retrieval rate of primary objects.

For the 3592 Model E05 (always in 3590 emulation mode), OAM derives the media type and capacity from the control unit. If EFMT2 recording technology is used to write on the volume (either by default or specifically requested), the MEDIA5 and MEDIA6 capacity is 488281088 KB. The MEDIA7 and MEDIA8 economy capacity is 97655808 KB. The MEDIA9 and MEDIA10 extended capacity is 700 GB.

Table 53 shows the entry for the optical configuration database (OCDB) MEDIATYP field. The media type is defined in the MEDIATYP field. These media types are defined:

- MEDIATYP field is 12, meaning Enterprise Extended Tape Cartridge. The CAPACITY value for this new media is 700 GB with the description of "Represents the approximate number of kilobytes of data for an IBM 3592 Enterprise Extended Tape Cartridge. This value is returned from the drive (3592 Model E05) and is used here as an approximation that is close to actual value."
- MEDIATYP field is 14, meaning Enterprise Extended WORM Tape Cartridge. The CAPACITY value for this new media is 700 GB with the description of "Represents the approximate number of kilobytes of data for an IBM 3592 Enterprise Extended Tape Cartridge. This value is returned from the drive (3592 Model E05) and is used here as an approximation that is close to actual value."

*Table 53. Library table column descriptions*

Column description	Name	DB2 type	DB2 attribute	Report label
Capacity of tape	CAPACITY	INTEGER	Not Null	CAPACITY
Media Type	MEDIATYP	CHAR(2)	Not Null	MEDIATYPE

The ERDS Physical ID (EPI) value for the 3592 Model E05 drive is a hex '12' and is stored in the DB2 TAPEVOL table of the OAM Optical Configuration Database (OCDB) for a volume written in either EFMT1 or EFMT2 by a 3592 Model E05 drive and displayed, as appropriate, in the volume display. In the standalone environment, drives must be put in their own unique esoteric to ensure that a volume written with EFMT2 recording technology is not inadvertently allocated to a drive that does not support EFMT2. For an IBM tape library, the SETOAM DATACLASS parameter at the storage group (or global level) can be used to specify a desired recording technology and ensure allocation to an appropriate drive.

Storage groups using 3592 Model E05 drives should be comprised of either WORM tape volumes or rewritable tape volumes. In addition, you should consider the separation of extended length, standard length and economy length media types. In an IBM tape library environment, the SETOAM DATACLASS parameter at the storage group (or global level) can be used to specify a desired media type. By specifying a DATACLASS media interchange for the storage group, MEDIA5, MEDIA6, MEDIA7, MEDIA8, MEDIA9 and MEDIA10 can be separated and prevent unintentionally writing on the wrong media type.

To assist the tape management system in mounting an appropriate media type in the stand-alone environment (non system-managed tape environment), the

DSNWITHSGNAME global keyword on the SETOAM statement in the CBROAMxx PARMLIB member appends the object storage group name to the OAM data set names. For more information, please refer to "Object tape data set low-level qualifier enhancement" on page 413.

---

## Object tape migration considerations

In the past when migrating to a new drive model with a new recording technology using media types that could also be used at a lower-level recording technology, customers marked their partially filled volumes as full or not writable and new write requests were done at the new recording technology. When migrating from 3592-J drives to 3592-E05, MEDIA5, MEDIA6, MEDIA7, and MEDIA8 volumes written on 3592-J drives with EFMT1 recording technology and not filled to capacity do not need to be marked as full or not writable. Data can be extended using the EFMT1 recording technology on the 3592 Model E05 drive.

---

## Object tape volume management support

OAM supports expiring an object tape volume whose data on the volume is all expired. The tape volume can be deleted or recycled if it has no valid data remaining because of expired data or all valid data has been moved to another volume due to recovery, the move volume utility, or the OSMC shelf manager processing.

As with the existing 3592 media types (MEDIA5, MEDIA6, MEDIA7 and MEDIA8), the 3592 Model E05 support for the additional media types (MEDIA9 and MEDIA10) includes special handling of WORM (MEDIA10) tape volumes that have expired. Because WORM tape volumes cannot be written from load point, they cannot be recycled.

With WORM tape, once the volume has been filled and data has been expired or DELETE has been requested on the MOVEVOL or RECOVERY command, the WORM tape volume is processed like the OAM RECYCLE MVSSCRATCH option. All knowledge of the volume is removed from the OAM DB2 tape volume database. Message, CBR2173I, is issued to signal the tape management system that a WORM volume has been expired or deleted and requires special handling based on the installation's procedures. If the WORM storage group has OAMSCRATCH or GROUP option specified for the TAPERECYCLEMODE keyword in the SETOAM statement in the CBROAMxx parmlib member, the WORM tape is still handled like the MVSSCRATCH option had been specified since WORM tape cannot be rewritten from load point. Message CBR2165I continues to be issued for a rewritable tape volume that has been expired or deleted.

Rewritable tape volumes being recycled (OAMSCRATCH or GROUP) have their data set format field reset to blank, indicating no current OAM data set written on the volume.



---

## Part 5. 3592 Model J



---

## Chapter 51. Introduction for 3592 Model J

This topic describes the IBM System Storage Tape System 3592 Model J tape drives and the Data Facility Storage Management Subsystem (DFSMS) software support needed to use them.

---

### IBM System Storage Tape System 3592

The IBM System Storage Tape System 3592 provides high capacity, performance, and reliability, along with a wide range of host connectivity. Specifically, the IBM System Storage Tape System 3592 offers these features:

- Creates tapes for archive files.
- Backs up and restores systems in case of system or disk storage problems.
- Stores high-speed, high-capacity sequential application data sets.
- Stores temporary data sets.
- Satisfies off-site data storage for disaster recovery.
- Provides data interchange with other systems that use 3592 subsystems.
- Supports WORM (write once, read many) tape data cartridges whose data cannot be altered.

---

### 3592 Model J tape drive

The IBM System Storage Tape System 3592 consists of one or more 3592 Model J tape drives and uses these IBM System Storage family of tape media:

- MEDIA5 - The IBM TotalStorage Enterprise Tape Cartridge (MEDIA5) physical media provides 300 GB of uncompressed capacity and 900 GB (assuming a 3:1 compression ratio) of compressed capacity depending on the type of data written.
- MEDIA6 - The IBM TotalStorage Enterprise WORM Tape Cartridge (MEDIA6) physical media provides 300 GB of uncompressed capacity and 900 GB (assuming a 3:1 compression ratio) of compressed capacity depending on the type of data written.
- MEDIA7 - The IBM TotalStorage Enterprise Economy Tape Cartridge (MEDIA7) physical media provides 60 GB of uncompressed capacity and 180 GB (assuming a 3:1 compression ratio) of compressed capacity depending on the type of data written.
- MEDIA8 - The IBM TotalStorage Enterprise Economy WORM Tape Cartridge (MEDIA8) physical media provides 60 GB of uncompressed capacity and 180 GB (assuming a 3:1 compression ratio) of compressed capacity depending on the type of data written.

The IBM System Storage Tape System 3592 Model J tape drive reduces data storage costs by increasing media capacity. In this information, the term 'J' refers to the Model J1A. You can use the 3592 Model J tape drive in the stand-alone environment or the tape library environment (automated or manual). Currently, the 3592 Model J tape drive does not have a cartridge loader.

The 3592 Model J tape drive offers these features:

- The 3592 Model J reads and writes EFMT1 (enterprise format 1) recording technology.
- The 3592 Model J uses the IBM System Storage family of tape media.

- The 3592 drives manufactured before the general availability of WORM capability and economy cartridges must have a microcode update to be able to read/write the WORM and economy cartridges. Drives without the updated microcode will reject the WORM and economy cartridges.
- The 3592 Model J optionally provides performance scaling by using only the first 60 GB of physical tape. The default is to use the full 300 GB capacity. This option is available on MEDIA5 tapes and is not available on MEDIA6, MEDIA7, or MEDIA8 tape cartridge media.
- The 3592 Model J emulates 3590 Model B1x tape drives (all 3592 tape cartridge media supported in this emulation mode) or 3490E tape drives with MEDIA5 tape cartridge media only. In a system-managed tape library environment (manual or automated), only 3590 Model B1x emulation is supported.
- The 3592 Model J coexists with 3490E and 3590 devices in the 3494 automated tape library.
- The 3592 Model J coexists with 3490, 3490E, and 3590 devices in a manual tape library.

The 3592 Model J tape drive is always in emulation mode, either as a 3590 Model B1x device or as a 3490E device. The 3592 Model J cannot use the MEDIA3 or MEDIA4 cartridges used in 3590 tape drives, nor the MEDIA1 or MEDIA2 cartridges used in 3490E tape drives.

**Related reading:**

- See *IBM System Storage TS1120 Tape Drive and Controller Introduction and Planning Guide*, GA32-0555, for additional information.

---

## Write Once, Read Many (WORM)

The write-once, read-many (WORM) function of tape data storage is accomplished on the 3592 Model J by a combination of microcode controls in the drive, and a special WORM tape cartridge (MEDIA6 or MEDIA8). All 3592 drives with the appropriate microcode version installed are capable of reading and writing WORM cartridges.

When the drive senses that a cartridge is a WORM cartridge, the microcode prohibits the changing or altering of user data already written on the tape. The microcode keeps track of the last appendable point on the tape by means of an overwrite-protection pointer stored in the cartridge memory (CM). Statistical Analysis and Reporting System (SARS) data can be written and updated on WORM tapes because the SARS data is not in the user area of the tape. Each WORM cartridge is identified using a world-wide unique cartridge identifier (WWCID), which is permanent and locked, providing another level of security for data that must be maintained. This permanent locked information is stored in both the cartridge CM and on the tape itself, and can also be associated with the unique barcode VOLSER.

**Note:** In some publications, the world-wide unique cartridge identifier (WWCID) may also be referred to as the world-wide identifier (WWID).

While overwriting of data on a WORM cartridge is not allowed, appending is permitted under certain conditions. These operations are allowed:

- Appending an additional labeled file following the final file on a tape volume. This overwrites the final tape mark of a final pair of tape marks followed by a header label group for the file to be appended. Appending is only permitted

where the trailer label group begins with a record that starts with EOF rather than EOJ. EOJ indicates that a file has been extended to a different volume.

- Appending an additional unlabeled file following the final file on a tape volume. This overwrites the final tape mark of a final pair of tape marks followed by the user file to be appended.
- Appending additional records to the final labeled file on a tape volume. This overwrites the final trailer label group and the tape mark immediately prior to the final trailer label group followed by the final file's user data records. Appending is only permitted where the trailer label group begins with a record that starts with EOF rather than EOJ.
- Appending additional records to the final unlabeled file on a tape volume. This overwrites the final tape mark or pair of tape marks immediately following the last user data record of the unlabeled file.
- Relabeling a tape volume when only a header label group has been written and no user data records nor trailer label group has been written. This rewrites the header label group, including volume labels and remaining initial header label group records, where volume identification and other fields in the header label group may be changed. This is prohibited if the header label group was followed by a trailer label group, user data records, or more than two tape marks because user data is never overwritten.

Header label groups and trailer label groups are recognized when all records within them conform to either IBM Standard or ANSI Standard label definitions. Any record with a prefix not recognized as conforming to these standards is assumed to be a user data record and causes overwriting of the entire label group to be prohibited. Double tape marks are assumed to occur only after the final recorded unlabeled file or the final label group on a tape. More than two adjacent tape marks indicate a null structure, such as a null user data file, between the first two of the multiple adjacent tape marks. For this reason, no more than two final tape marks are overwritten in any attempt to append.

In addition, the 3592 drive permits certain normal error recovery actions to succeed when writing to a volume that had been previously interrupted due to some equipment, connectivity, or power malfunction. In particular, in ESCON and FICON attachment environments, certain channel error recovery programs are supported via a mode of operation where the ESCON / FICON controller simulates the rewriting of records. The simulation of rewriting of records presents the appearance at the host of successful rewrites of logical records. The simulation succeeds only if the actual record already recorded on the medium precisely matches the record sent to the 3592 drive from the host.

---

## **z/OS software support for the 3592 Model J tape drive**

Use z/OS software with the 3592 Model J to increase your data storage capacity with the IBM System Storage family of tape media and the EFMT1 recording technology. Table 54 on page 342 describes z/OS DFSMS components, Multiple Virtual Storage (MVS) Device Allocation, Environmental Recording, Editing, and Printing (EREP), DFSORT, and JES3 that provide software support for the 3592 Model J.

Table 54. Components that provide software support for the 3592 Model J tape drive

Component	Function
AMS	AMS allows the use of the EFMT1 recording technology and IBM System Storage family of tape media for volumes as well as the printing and displaying of information about the recording technology and media type.
Device Services	Device Services manages the IBM System Storage Tape System 3592 devices.
DFSORT	DFSORT works without change with the IBM System Storage Tape System 3592 devices.
EREP	EREP provides device type information when formatting LOGREC records.
DFSMSHsm	DFSMSHsm allows the use of 3592 devices and media for DFSMSHsm-related activities. Customers can also choose to limit the data written to the first 60 GB (the optimally scaled performance capacity) of the IBM TotalStorage Enterprise Tape Cartridge (MEDIA5) by using the data class performance scaling attribute. This option is not available on MEDIA6, MEDIA7, or MEDIA8 tape cartridge media.
ISMF	ISMF allows the use of 3592 devices and media in the ISMF Data Class Application, Mountable Tape Volume Application, and the Tape Library Management Application. In addition, the data class performance scaling attribute, if selected, allows the user to limit the amount of data written to each tape. This applies to MEDIA5 tape cartridges. For 3592 Model J, the limit is the first 20% (60 GB physical) of tape media.
z/OS Multiple Virtual Storage (MVS) Allocation	z/OS MVS Allocation allows the use of the EFMT1 recording technology and IBM System Storage family of tape media when using the Dynamic Allocation Text Unit DALINCHG.
OAM	OAM tape library support allows the use of the EFMT1 recording technology and IBM System Storage family of tape media in the IBM 3494 Automated Tape library and in the IBM manual tape library. OAM object tape support allows the use of 3592 devices and media for object-related activity. Customers can also choose to limit the data written to the first 60 GB (the optimally scaled performance capacity) of the IBM TotalStorage Enterprise Tape Cartridge (MEDIA5) by using the data class performance scaling attribute. This option is not available on MEDIA6, MEDIA7, or MEDIA8 tape cartridge media.

Table 54. Components that provide software support for the 3592 Model J tape drive (continued)

Component	Function
OCE/IFGOJES3	OCE/IFGOJES3 allows the use of the EFMT1 recording technology and IBM System Storage family of tape media in the stand-alone environment and the tape library environment. New devices can also be used in a tape library that is JES3-managed.
DFSMSrmm	DFSMSrmm allows the use of the EFMT1 recording technology and IBM System Storage family of tape media. DFSMSrmm records the volume capacity for a volume including the volume capacity when performance scaling is specified. This applies to the IBM TotalStorage Enterprise Tape Cartridge (MEDIA5).
SMS	SMS allows the use of the EFMT1 recording technology and IBM System Storage family of tape media. You can specify the data class performance scaling attribute for the IBM TotalStorage Enterprise Tape Cartridge (MEDIA5). This option is not available on MEDIA6, MEDIA7, or MEDIA8 tape cartridge media.

## Using 3592 Model J tape drives in an IBM tape library environment

z/OS DFSMS provides device allocation and media management in 3494 automated or manual tape library environments for 3592 Model J tape drives. This full support is required when 3592 Model J tape drives are installed in an IBM tape library environment. 3592 Model J drives can coexist with 3950 Model B1x, 3590 Model E1x, and 3590 Model H1x drives in the same library.

Inside an IBM tape library, only 3590 Model B1x emulation is supported. The system-managed tape library support recognizes the device as its real device type instead of its emulated device type; this enables "real" and emulated Model B1x tape drives to coexist and be properly managed in the same IBM tape library.

To request WORM media in a system-managed tape library environment and to ensure that WORM media is only used when explicitly requested, if a WORM scratch volume is to be used, media types MEDIA6 or MEDIA8 must be explicitly specified through data class. If a media type is not specified through data class, MEDIA5 is the primary scratch media type and MEDIA7 is the alternate scratch media type if there are no MEDIA5 scratch volumes available.

Before using the new 3592 media (MEDIA6, MEDIA7, or MEDIA8) in the system-managed tape library environment (automated or manual), ensure that all existing 3592 drives in the library are upgraded to support the new media types. Otherwise, job failures may occur with a drive with the incorrect microcode load being allocated.

## Using 3592 Model J tape drives in a stand-alone environment

3592 Model J tape drives emulate already-supported tape devices. To use these drives in a nonlibrary environment, you must manage mixed media and resolve drive allocation ambiguities between 3592 Model J drives and the actual models of drives that are being emulated. This is because the emulated device type is recorded in the data set records of user catalogs. You must manage media and device allocation according to your installation's storage management policies. You must segregate real and emulated device types.

Before using the new 3592 media (MEDIA6, MEDIA7, or MEDIA8) in the stand-alone environment, ensure that all 3592 devices within the same esoteric are at the same 3592 microcode support level to ensure that a 3592 device is allocated that supports the new media types.

**Recommendation:** Use a manual tape library, DFSMSrmm, third-party tape management software, or write your own applications when using 3592 Model J tape drives in a stand-alone environment.

---

### Implementation considerations for Using 3592 Model J tape drives

Consider these implementation tasks for using DFSMS software support for 3592 Model J tape drives.

- For non-specific mount requests in a stand-alone (non-SMS) tape environment, there are no automatic system controls for WORM cartridges. This can result in inadvertent and irreversible writes to WORM media. Using the tape management system pooling support to set up pools to select WORM versus R/W tape media and selecting economy length versus standard length cartridges help to guarantee that the correct media type is mounted.

In addition, SMS data class policies can be used to control WORM mounts for stand-alone, non-specific mount requests. There are two ways to enforce the data class media policy:

- Specify the DEVSUP $xx$  keyword, ENFORCE\_DC\_MEDIA=ALLMEDIATY. ALLMEDIATY enforces all data class media policies for all stand-alone scratch mounts.
- Specify the DEVSUP $xx$  keyword, ENFORCE\_DC\_MEDIA=MEDIA5PLUS. MEDIA5PLUS ensures data class media policies for MEDIA5, MEDIA6, MEDIA7, and MEDIA8 are enforced for stand-alone scratch mounts.
- In the manual tape library (SMS) environment, WORM scratch mounts can be managed through the tape management system pooling support instead of data class. New DEVSUP $xx$  keyword, MTL\_NO\_DC\_WORM\_OK, allows a WORM scratch volume to be used, even if it was not explicitly requested through data class.
- For the IBM TotalStorage Enterprise Tape Cartridge (MEDIA5), use the performance scaling attribute specified through the ISMF data class application if you want to select optimal performance scaling for certain types of jobs and applications. The default setting is to use the tape to its full 300 GB capacity. This can be specified for tape allocations that are inside or outside an IBM tape library environment. The performance scaling option is not available on MEDIA6, MEDIA7, or MEDIA8 tape cartridge media.

**Note:** In addition, the 3592 drive also supports a 260 GB segmented format of the 300 GB (MEDIA5) tape cartridge that provides fast access in the first 60 GB segment and slower access in the remaining 200 GB segment. However, this format is not currently supported in the zSeries environment and when detected



during OPEN processing (file sequence 1, DISP=NEW), results in the MEDIA5 tape cartridge being reformatted to either its 60 GB scaled or 300 GB full capacity format as indicated in the performance scaling data class attribute.

- If you have mixed 3590-1 devices in a non-SMS environment, you need to define a unique esoteric name for each recording technology. Identify the esoteric names to DFSMSHsm using the SETSYS USERUNITTABLE(*esoteric1:esoteric1, esoteric2:esoteric2...*) command to ensure that the correct device type is requested when the tape is mounted for input or output. If your installation uses SMS-managed tape devices or has a single 3590-1 recording technology, you do not need to define an esoteric for those devices; you might need to specify that DFSMSHsm allows mixed devices in the 3590-1 generic name (see APAR OW57282).
- In the stand-alone (non-SMS) environment, perform these implementation steps:
  1. Define data classes or alter existing data classes to:
    - Use the performance scaling attribute with the IBM TotalStorage Enterprise Tape Cartridge (MEDIA5).
    - To take advantage of the new data class media enforcement support enabled through DEVSUP $xx$  (ENFORCE\_DC\_MEDIA=ALLMEDIATY or ENFORCE\_DC\_MEDIA=MEDIA5PLUS).
  2. Update the ACS routine to assign the appropriate data class construct.
- In an IBM tape library environment, perform these implementation steps:
  1. Define or alter existing data classes to specify the recording technology, media type, and performance scaling attributes, as appropriate. The performance scaling attribute applies to the IBM TotalStorage Enterprise Tape Cartridge (MEDIA5). This option is not available on MEDIA6, MEDIA7, or MEDIA8 tape cartridge media.
  2. Define or alter existing tape storage group constructs.
  3. Update ACS routines to direct allocation to appropriate 3592 devices and media.
  4. Validate and activate the new or modified SMS configuration.
  5. Update parmlib member DEVSUP $xx$  (as appropriate) with the MEDIA $x$  parameters (MEDIA5, MEDIA6, MEDIA7, and MEDIA8) specifying the library partitioning category codes.

**Related reading:**

See Chapter 52, “Migration to the software support for 3592 Model J tape drives,” on page 347 for migration information and implementation information.



---

## Chapter 52. Migration to the software support for 3592 Model J tape drives

DFSMS software support for the 3592 Model J addresses media management and data allocation in an IBM 3494 Automated Tape Library and in the manual tape library (MTL). You can manage media and allocate data to appropriate nonlibrary drives through segregation of the real and emulating drives, third-party tape management software, or user-written applications. You can use the 3592 Model J drive and MEDIA5 on systems that are running OS/390 V2R10 and above. However, to use the new 3592 media types, MEDIA6, MEDIA7, and MEDIA8, z/OS V1R3 and above must be used.

This topic outlines the tasks and associated procedures that must be performed to migrate to software support for the 3592 Model J tape drive in these environments:

- Stand-alone environment
- IBM tape library environment
- OAMplex
- HSMplex

---

### Understanding coexistence considerations for 3592 Model J1A

Coexistence support for the base 3592 support and MEDIA5 had been provided at OS/390 V2R10 and above by installing the needed full-support PTFs without the Device Services enabling PTF. The Device Services coexistence support prevented the 3590 Model J devices from coming online on a system that did not have all of the full-support PTFs installed. Installation of the base support enabling PTF then brought in all of the needed full-support PTFs and enabled the base 3592 support on that system.

In support of the new 3592 media types, MEDIA6, MEDIA7, and MEDIA8, coexistence support is also provided at OS/390 V2R10 and above. However, since full support for the new media types is only available at z/OS V1R3 and above, coexistence support is provided at OS/390 V2R10 through the installation of separate coexistence specific PTFs. At the full support release levels, coexistence support is provided by installing the needed full-support PTFs without the Device Services enabling PTF. As with the base 3592 support, installation of the new support's enabling PTF will bring in all of the needed support PTFs for MEDIA6, MEDIA7, and MEDIA8. Also, if the system is enabled for the base 3592 support and is not enabled for the new media support, it can still be used for MEDIA5 processing. Before using the new media types, ensure that all of the support code is installed as appropriate (full or coexistence). See Table 55 on page 348 for a discussion of the coexistence PTFs that may be needed.

You must install coexistence PTFs on systems that will not have all of the 3592 Model J support installed (either the 3592 base support and/or the additional support for the new media types).

Review the coexistence migration tasks described in these topics.

Table 55. Coexistence migration tasks

Environment	Coexistence considerations
Stand-Alone	<p>As described in Chapter 51, "Introduction for 3592 Model J," on page 339, z/OS DFSMS and related licensed programs provide full support for the base 3592 and MEDIA5 with OS/390 V2R10 and above, with support for the new media types, MEDIA6, MEDIA7, and MEDIA8, being provided with z/OS V1R3 and above. The base 3592 support enables the tape drives to operate in the stand-alone environment in either 3590 Model B1x or 3490E emulation and to coexist with other 3590-1 or 3490 tape drives. However, to use the new media types, MEDIA6, MEDIA7, or MEDIA8, only 3590 Model B1x emulation is supported.</p>
IBM Tape Library	<p>As described in Chapter 51, "Introduction for 3592 Model J," on page 339, z/OS DFSMS and related licensed programs provide full support for the base 3592 and MEDIA5 with OS/390 V2R10 and above, with support for the new media types, MEDIA6, MEDIA7, and MEDIA8, being provided with z/OS V1R3 and above. The system-managed tape library support allows the tape drives to operate in an ATL or MTL environment as 3590 Model B1x devices, providing device allocation and tape media management support. This support allows the 3592 Model J tape drives to coexist with other 3590-1 tape drives in the same tape library. However, prior to using the new media types (MEDIA6, MEDIA7, and MEDIA8), ensure that all existing 3592 library drives have had their microcode upgraded in support of the new media types, otherwise job failures may occur with a 3592 drive with the wrong microcode level being allocated.</p>

Table 55. Coexistence migration tasks (continued)

Environment	Coexistence considerations
OAMplex	<p>For OAM's object support customers, in addition to the planning steps required for migration to the software support for the 3592 Model J tape drives in the stand-alone and IBM tape library environments, there are coexistence considerations your installation must take into account before you install the software in an OAMplex:</p> <ul style="list-style-type: none"> <li>• For the base 3592 support and MEDIA5, OAM object tape coexistence support is provided at OS/390 V2R10 and above, through installation of the full support PTF. Coexistence support for the new media types (MEDIA6, MEDIA7, and MEDIA8) is provided at OS/390 V2R10 and above, with a separate coexistence PTF being provided at OS/390 V2R10. With z/OS V1R3 and above, OAM object tape coexistence support is provided in the full support PTF. Along with the support for the new media types (MEDIA6, MEDIA7, and MEDIA8) built into the coexistence and full support PTF is full support for the new OAM object tape data set name format (with the storage group name appended). In support of the new data set name format, coexistence and full support systems must have the DSNFMT column added to the TAPEVOL table in the Optical Configuration Database. Only one system in an OAMplex needs to run CBRSMPS to add the TAPEVOL column, but all systems in the OAMplex need to run CBRPBIND.</li> <li>• OAM coexistence support prevents lower-level systems from selecting volumes with ERDS Physical Identifier (EPI) values for object write requests, and it also prevents the up-level volumes (MEDIA6, MEDIA7, and MEDIA8) from being selected on a system that is not enabled for the new media support.</li> <li>• OAM object support has coexistence considerations when running in an OAMplex environment with at least one system with the full support installed and enabled and at least one system at a release level where the new devices are supported; however, all of the support is not installed and enabled. In this mixed support environment, it is possible for a retrieve request to be received for an object, which resides on a tape cartridge volume which was written in EFMT1 track format (written on a 3592 Model J device) by a system that does not support the new devices and MEDIA5, or by a system that supports the new devices, but does not support the new media types (MEDIA6, MEDIA7, or MEDIA8), or both. If this is the case, coexistence support will be provided to allow OAM to attempt to locate an instance of OAM in the OAMplex where the full support is installed and enabled. If an instance of OAM is found where the request can be processed, the OAM on the system where the request originated will ship the retrieve request to the target system using XCF messaging services. Once 3592 Model J devices are used in an OAMplex environment and objects are written to tape volumes with the new EPI value recorded, it is expected that any OAM on a system where the full support is installed and enabled is eligible for processing requests using that volume. Therefore, the devices must be made available to all instances of OAM where the full support is installed.</li> </ul>
OCE (Open / Close / End-of-Volume)	<p>In support of the new media types (MEDIA6, MEDIA7, and MEDIA8), coexistence support is provided for the new media types on OS/390 V2R10 and above to prevent the new media types from being used on non-supporting systems. With the coexistence support installed, an abend will occur if an up-level volume is mounted on a down-level system.</p>

Table 55. Coexistence migration tasks (continued)

Environment	Coexistence considerations
HSMplex	<p>For the base 3592 support and MEDIA5, HSM coexistence support is provided at OS/390 V2R10 and above, through installation of the full support HSM PTF.</p> <p>HSM coexistence support for the new media types (MEDIA6, MEDIA7, and MEDIA8) is provided at the OS/390 V2R10 level through the OCE coexistence PTF. At the z/OS V1R3 level and above, HSM coexistence is provided by applying both the OCE and the HSM full support PTFs. This will ensure HSM does not use MEDIA6, MEDIA7, or MEDIA8 tapes on a non-supporting system.</p>

---

## Preparing to install the software

See *IBM System Storage TS1120 Tape Drive and Controller Introduction and Planning Guide*, GA32-0555, for hardware requirements.

Coexistence support had been provided with OS/390 V2R10 for the base 3592 support and MEDIA5 and also provided for the new media types, MEDIA6, MEDIA7, and MEDIA8. Some of the new coexistence support is provided by installing the full-support APARs without the enabling APAR, and other coexistence support is provided through separate PTFs depending on the release level. The 3592 base support is available with OS/390 V2R10 and above, with support for the new media types being provided with z/OS V1R3 and above.

---

## Installing the appropriate PTFs

Refer to the 3592 PSP bucket for the APAR and PTF numbers applicable for each release. An enabling PTF exists at the base 3592 support level to provide full device support for the 3592 Model J and in addition to this, there is a new enabling PTF that exists for the 3590 Model J for MEDIA6, MEDIA7, and MEDIA8 support. Installation of the appropriate enabling PTF pulls in all of the needed support PTFs and indicates to the system that all of the needed software support is installed.

In addition, as appropriate for your environment and release level, determine what coexistence PTFs are needed for your environment both from a base 3592 support level and also in support of the new media types.

---

## Planning for DFSMS software support for the 3592 Model J

The planning steps you must consider to successfully install the 3592 Model J software, (base support and MEDIA5), and additionally, the support for new media types, MEDIA6, MEDIA7, and MEDIA8, vary depending upon the tape environment you have installed. Table 56 on page 351 discusses planning considerations for stand-alone environments (including tape devices installed in vendors' automated tape libraries) and for IBM tape library environments.

Table 56. 3592 Model J planning considerations

Area	Planning considerations
System customization: stand-alone environment	<ol style="list-style-type: none"> <li>1. Determine whether you will need help from your tape management system vendor and contact them, if needed.</li> <li>2. Determine the 3592 drives that will have their microcode upgraded in support of the new media types (MEDIA6, MEDIA7, and MEDIA8) and ensure that the drives in the same esoteric are at the same support level. It is recommended that you upgrade all existing 3592 drives prior to using the new media types.</li> <li>3. Determine which systems should have coexistence support and which systems should have full support.</li> <li>4. Determine when to IPL the host machine after installing the coexistence PTFs, if needed.</li> <li>5. Determine when to IPL the host machine after installing all necessary PTFs.</li> </ol>
System customization: IBM library tape environment	<ol style="list-style-type: none"> <li>1. Determine whether you will need help from your tape management system vendor and contact them, if needed.</li> <li>2. Determine the libraries that will be using the new media types (MEDIA6, MEDIA7, and MEDIA8) and ensure that all 3592 library drives are upgraded prior to using the new media types. Also, a scratch allocation for a particular media type may have several libraries that are eligible for the request (have 3592 drives present), so ensure that all of the eligible 3592 library drives are upgraded for the new support.</li> <li>3. Identify the installation exit changes that are needed.</li> <li>4. Determine which systems should have coexistence support and which systems should have full support.</li> <li>5. Determine when to IPL the host machine after installing the coexistence PTFs, if needed.</li> <li>6. Determine when to IPL the host machine after installing all necessary PTFs.</li> </ol>

Table 56. 3592 Model J planning considerations (continued)

Area	Planning considerations
System customization: OAM object tape environment	<p>The planning steps that you must consider in tape environments that use OAM objects vary depending upon the type of environment that is installed.</p> <ol style="list-style-type: none"> <li>1. If you install the new 3592 Model J devices in a stand-alone environment:               <ol style="list-style-type: none"> <li>a. Follow the system customization planning steps listed for a stand-alone environment.</li> <li>b. Determine the esoteric or generic device names that need to be added to STORAGEGROUP statements in the CBROAMxx member of PARMLIB for the object storage groups that are to use the new devices.</li> <li>c. Determine whether to use the new global keyword DSNWITHSGNAME on the SETOAM statement in the CBROAMxx member of PARMLIB to append the object storage group name to the OAM object tape data set names. See “Object tape data set low-level qualifier enhancement” on page 413 for additional information.</li> </ol> </li> <li>2. If you install the new 3592 Model J devices in an IBM tape library:               <ol style="list-style-type: none"> <li>a. Follow the system customization planning considerations listed for an IBM tape library environment.</li> <li>b. Determine the new data classes that need to be defined in STORAGEGROUP statements in the CBROAMxx member of PARMLIB for the object storage groups that are to use the new devices.</li> </ol> </li> <li>3. In addition, if you install the new 3592 Model J devices in an OAMplex:               <ol style="list-style-type: none"> <li>a. Ensure that the new 3592 Model J devices are available to all instances of OAM where this software is installed.</li> <li>b. Determine whether systems exist that will require coexistence support. This situation is particularly important in an OAMplex where at least one system has the full-support software installed and enabled, and at least one system will not have all of the support installed or enabled. Coexistence support is needed if not all of the systems in the OAMplex will be at the same full-support level.</li> <li>c. Installation of the full or coexistence support PTF for the new media types (MEDIA6, MEDIA7, and MEDIA8) brings in support for the new object tape data set name format. In support of this new function (even if this function is not used), the DSNFMT column must be added to the TAPEVOL table in the Optical Configuration Database. Only one system in an OAMplex needs to run CBRSMPPDS to add the TAPEVOL column, but all systems in the OAMplex need to run CBRPBIND.</li> <li>d. To provide this coexistence support, as appropriate for the support and the release level, install the OAM full-support PTF without the enabling PTF or any separate coexistence support PTF.</li> <li>e. Determine when to IPL the host machine after installing the coexistence PTFs, if needed.</li> </ol> </li> </ol>
System customization: DFSMSHsm	See “Implementation considerations for Using 3592 Model J tape drives” on page 344 and “DFSMSHsm tips” on page 390.



Table 56. 3592 Model J planning considerations (continued)

Area	Planning considerations
Storage administration: stand-alone tape environment	<ol style="list-style-type: none"> <li>1. Determine how to setup your tape management systems pooling support to segregate rewritable (MEDIA5 and MEDIA7) and WORM (MEDIA6 and MEDIA8) media and also to segregate the standard and economy length cartridges, as appropriate for their job and application usage.</li> <li>2. Review the usage of the DEVSUP<math>xx</math> PARMLIB option, ENFORCE_DC_MEDIA, (optional) to ensure that the media type mounted is the media type requested through data class. This can be used in conjunction with the tape management systems pooling support as an additional safety check.</li> <li>3. Review the existing SMS data class media policies to ensure compatibility with existing tape scratch pool policies before enabling the DEVSUP<math>xx</math> PARMLIB option, ENFORCE_DC_MEDIA.</li> <li>4. Determine if media should be used at full capacity or scaled for optimal performance. If you decide to use the performance scaling attribute (available with MEDIA5 tape cartridges only), you can:               <ol style="list-style-type: none"> <li>a. Define a data class that requests performance scaling.</li> <li>b. Modify or create ACS routines to associate the tape output functions using performance scaling with a data class that requests performance scaling.</li> </ol> </li> <li>5. Determine how to allocate media to appropriate nonlibrary drives. Consider using the IBM manual tape library. You can also segregate the real drives from the emulating drives, use third-party tape management software, or use customer-written applications.</li> <li>6. Identify any needed changes to the hardware configuration definition (HCD) to define the new devices.</li> </ol>
Storage administration: IBM tape library environment	<ol style="list-style-type: none"> <li>1. Review the usage of the DEVSUP<math>xx</math> PARMLIB option, MTL_NO_DC_WORM_OK, if the WORM cartridges in the manual tape library environment will be mounted through use of the tape management systems pooling support versus a data class WORM media specification.</li> <li>2. Determine the 3592 media usage of rewritable (MEDIA5 and MEDIA7) and WORM (MEDIA6 and MEDIA8) media and also the usage of the standard and economy length cartridges. Then make the appropriate data class definition updates to select the appropriate media type. WORM media can only be used if explicitly requested through data class.</li> <li>3. Review ACS routines for changes needed in selecting tape storage groups and libraries that have the new 3592 Model J devices.</li> <li>4. Determine the data class updates that are needed to use the recording technology, media type, and performance scaling data class attribute (performance scaling available with MEDIA5 tape cartridges only).</li> <li>5. Identify any needed changes to the HCD to define the new devices.</li> <li>6. To define the partitioning category code for MEDIA5, MEDIA6, MEDIA7, and MEDIA8, tape cartridges, specify the appropriate parameter of the DEVSUP<math>xx</math> parmlib member.</li> </ol>

Table 56. 3592 Model J planning considerations (continued)

Area	Planning considerations
Storage administration: OAM object tape environment	<p>The planning steps that you must consider in tape environments that use OAM objects vary depending upon the type of environment that is installed.</p> <ol style="list-style-type: none"> <li>1. If you install the new 3592 Model J devices in a stand-alone environment, follow the storage administration planning steps listed for a stand-alone environment.</li> <li>2. If you install the new 3592 Model J devices in an IBM tape library:               <ol style="list-style-type: none"> <li>a. Follow the storage administration planning steps listed for an IBM tape library environment.</li> <li>b. Review ACS routines for STORE or CTRANS environments and make any changes needed to ensure proper class assignment.</li> </ol> </li> <li>3. If you install the new 3592 Model J devices in an OAMplex, you must make the devices available to all instances of OAM where the full support is installed.</li> </ol>

Implementing this change could affect these areas of your processing environment:

Area	Considerations
Storage Administration	<p>For the base 3592 support and MEDIA5, these NaviQuest sample jobs have been changed for this function:</p> <ul style="list-style-type: none"> <li>• ACBJBAD1 is the sample job used to define, alter, or display a data class.</li> <li>• ACJBAIL is the sample job used to generate a data class list and a data class report.</li> <li>• ACJBAIN is the sample job used to generate a data class report.</li> </ul> <p>For the new 3592 media support (MEDIA6, MEDIA7, and MEDIA8), these NaviQuest sample job has been changed for this function:</p> <ul style="list-style-type: none"> <li>• ACBJBAD1 is the sample job used to define, alter, or display a data class.</li> </ul> <p>ISMF panels have been changed. See <i>z/OS DFSMSdfp Storage Administration</i> for information about the ISMF panel changes. See Chapter 55, "ISMF modifications for 3592 Model J," on page 383 for information about ISMF support for the 3592 Model J.</p>
Operations	<p>These commands have been updated with this support:</p> <ul style="list-style-type: none"> <li>• DEVSERV QTAPE</li> <li>• DISPLAY SMS,LIBRARY(<i>libname</i>),DETAIL</li> <li>• DISPLAY SMS,VOLUME</li> <li>• IDCAMS ALTER LIBRARYENTRY</li> <li>• IDCAMS ALTER VOLUMEENTRY</li> <li>• IDCAMS CREATE LIBRARYENTRY</li> <li>• IDCAMS CREATE VOLUMEENTRY</li> <li>• IDCAMS DCOLLECT</li> <li>• IDCAMS LISTCAT</li> <li>• LIBRARY DISPDRV</li> <li>• LIBRARY ENTER</li> <li>• LIBRARY SETCL</li> </ul>
Auditing	None.

Area	Considerations
Application development	<p>The mapping macros and installation exits listed have been changed for this function.</p> <ul style="list-style-type: none"> <li>• CBRTDSI - Maps the Tape Device Selection Information</li> <li>• CBRTVI - Maps the Tape Volume Information</li> <li>• CBRUXCPL - Installation Exit CBRUXCUA Parameter List</li> <li>• CBRUXEPL - Installation Exit CBRUXENT Parameter List</li> <li>• CBRUXJPL - Installation Exit CBRUXEJC Parameter List</li> <li>• CBRUXNPL - Installation Exit CBRUXVNL Parameter List</li> <li>• DALINCHG - Dynamic Allocation DALINCHG Text Unit</li> <li>• EDGRXEXT - Maps the data set records in the DFSMSrmm extract data set</li> <li>• EDGEXTSY - Maps the extract data set symbols used with DFSORT</li> <li>• EDGRVEXT - Maps the volume records in the DFSMSrmm extract data set</li> <li>• EDGSMFSY - Maps the SMF record symbols used with DFSORT</li> <li>• EDGSVREC - Maps the DFSMSrmm SMF volume records</li> <li>• IECLOGT - Maps the tape log data</li> <li>• IECOEVSE - Volume security verification exit parameter list</li> <li>• IECUCBCX - Maps the Tape UCB Device Class extension</li> <li>• IFGTEP - Maps the installation exit main parameter list</li> <li>• IFGWAX - Work area extension</li> <li>• IHADFVT - Maps the data facilities vector table</li> </ul>

Area	Considerations
Diagnostic procedures	<p>The messages listed have been changed for this support.</p> <ul style="list-style-type: none"> <li>• ARC0309I</li> <li>• ARC0332A</li> <li>• ARC0332R</li> <li>• ARC0343I</li> <li>• ARC0734I</li> <li>• ARC1236I</li> <li>• ARC1336I</li> <li>• ARC6410E (new)</li> <li>• CBR0113I</li> <li>• CBR0114I</li> <li>• CBR0119I</li> <li>• CBR0185I</li> <li>• CBR0203I</li> <li>• CBR0213I (new)</li> <li>• CBR1082I</li> <li>• CBR1083I</li> <li>• CBR1084I</li> <li>• CBR1110I</li> <li>• CBR1180I</li> <li>• CBR1220I</li> <li>• CBR1240I</li> <li>• CBR2167I</li> <li>• CBR2173I (new)</li> <li>• CBR3660A</li> <li>• CBR3726I</li> <li>• CBR3781I</li> <li>• CBR4105I</li> <li>• CBR4196D</li> <li>• CBR4173I (new)</li> <li>• CBR6419I</li> <li>• CBR9097I (new)</li> <li>• EDG3357I (new)</li> <li>• EDG4055I (new)</li> <li>• EDG4056I (new)</li> <li>• IEA253I</li> <li>• IEC147I</li> <li>• IEC501A</li> <li>• IEC501E</li> <li>• IEC502E</li> <li>• IEC705I</li> <li>• IEE459I</li> <li>• IGF513I</li> </ul>
Automation products	None.

Area	Considerations
General use	For DFSMSrmm, use the RMM ADDVOLUME subcommand, the RMM CHANGEVOLUME, and the RMM SEARCHVOLUME subcommand for the recording technology EFMT1 and for the media types MEDIA5, MEDIA6, MEDIA7, and MEDIA8.

## Implementing the DFSMS software support for the 3592 Model J

To implement the 3592 Model J software support, perform the system-level and application-level tasks listed in these tables. **Required** tasks apply to any DFSMS installation enabling the function. **Optional** tasks apply to only specified operating environments or to situations where there is more than one way to set up or enable the function. For more details on the procedures associated with a given task, see the reference listed.

System-level tasks	Condition	Procedure reference
<p><i>Stand-alone tape environment</i></p> <ol style="list-style-type: none"> <li>1. Make any needed changes to the HCD to define the new devices.</li> <li>2. If more than one recording technology is used for the same device type, create a unique esoteric for each of the recording technologies. Use the esoteric unit names in DFSMSHsm to direct allocations uniquely to each group of devices.</li> <li>3. If performance scaling is used (available with MEDIA5 tape cartridges only), update or create ACS routines to assign a data class to tape output functions. For example, for DFSMSHsm, you can filter on single file tape data set names used by DFSMSHsm functions. Define the data class with the performance scaling attribute.</li> <li>4. Add new device esoteric unit names or generic unit names to STORAGEGROUP statements in the CBROAMxx member of PARMLIB for the object storage groups that are to use the new devices. The esoteric or generic unit name must consist of 3592 Model J drives exclusively because the EFMT1 recording technology is not compatible with other recording technologies.</li> <li>5. Install coexistence PTFs as appropriate.</li> <li>6. IPL the system.</li> </ol>	Required	<ul style="list-style-type: none"> <li>• <i>z/OS DFSMS OAM Planning, Installation, and Storage Administration Guide for Object Support</i></li> <li>• <i>z/OS HCD User's Guide</i></li> <li>• <i>z/OS DFSMSHsm Implementation and Customization Guide</i></li> </ul>
<p><i>IBM tape library environment</i></p> <ol style="list-style-type: none"> <li>1. Define or alter existing data class constructs as appropriate, to specify the EFMT1 recording technology, MEDIA5, MEDIA6, MEDIA7, or MEDIA8, media type, and the performance scaling attributes (performance scaling available with MEDIA5 tape cartridges only).</li> <li>2. Define or alter existing storage group constructs to include libraries with the new 3592 Model J devices.</li> <li>3. Update ACS routines to direct allocation to the 3592 Model J device as requested.</li> <li>4. Validate and activate any new or modified SMS configuration.</li> <li>5. Make any needed changes to the HCD to define the new devices.</li> <li>6. To define the partitioning category code for MEDIA5 MEDIA6, MEDIA7, or MEDIA8, tape cartridges, specify the appropriate parameter of the DEVSUPxx parmlib member.</li> <li>7. When systems are sharing a library with 3592 Model J devices installed, install coexistence PTFs or full-function PTFs on all involved systems.</li> <li>8. IPL the system.</li> </ol>	Required	<ul style="list-style-type: none"> <li>• <i>z/OS DFSMS OAM Planning, Installation, and Storage Administration Guide for Tape Libraries</i></li> <li>• <i>z/OS HCD User's Guide</i></li> <li>• <i>z/OS DFSMSdfp Storage Administration</i></li> </ul>

System-level tasks	Condition	Procedure reference
<p><i>OAM object tape environment</i></p> <p>The migration steps that you must take in tape environments that use OAM objects vary depending upon the type of environment that is installed:</p> <ol style="list-style-type: none"> <li>1. If you install the new 3592 Model J devices in an OAMplex:               <ol style="list-style-type: none"> <li>a. Make the new 3592 Model J devices available to all instances of OAM where this software is installed.</li> <li>b. Install coexistence PTFs as appropriate.</li> <li>c. Add the DSNFMT column to the TAPEVOL table in the Optical Configuration Database. Run CBRSMPPDS sample JCL to add the DSNFMT column. After the column has been added, run CBRPBIND. Only one system in an OAMplex needs to run CBRSMPPDS to add the TAPEVOL column, but all systems in the OAMplex must run CBRPBIND.                   <p>Consider setting DSNWITHSGNAME in the SETOAM statement in the CBROAMxx PARMLIB member. Review your ACS routines if appending the storage group name to OAM data set names (DSNWITHSGNAME).</p> </li> <li>d. IPL the system.</li> </ol> </li> <li>2. If you install the new 3592 Model J devices in an IBM tape library:               <ol style="list-style-type: none"> <li>a. Follow the migration steps listed for an IBM tape library environment.</li> <li>b. Define the new data classes in STORAGEEGROUP statements in the CBROAMxx member of PARMLIB for the object storage groups that are to use the new devices.</li> <li>c. Add the DSNFMT column to the TAPEVOL table in the Optical Configuration Database. Run CBRSMPPDS sample JCL to add the DSNFMT column. After the column has been added, run CBRPBIND. Consider setting DSNWITHSGNAME in the SETOAM statement in the CBROAMxx PARMLIB member. Review your ACS routines if appending the storage group name to OAM data set names (DSNWITHSGNAME).</li> <li>d. Make the needed changes to ACS routines for ALLOC, STORE, or CTRANS environments.</li> </ol> </li> <li>3. If you install the new 3592 Model J devices in a stand-alone environment:               <ol style="list-style-type: none"> <li>a. Follow the migration steps listed for a stand-alone environment.</li> <li>b. Add new device esoteric unit names or generic unit names to STORAGEEGROUP statements in the CBROAMxx member of PARMLIB for the object storage groups that are to use the new devices. The esoteric or generic unit name must consist of 3592 Model J drives exclusively because the EFMT1 recording technology is not compatible with other recording technologies.</li> <li>c. Add the DSNFMT column to the TAPEVOL table in the Optical Configuration Database. Run CBRSMPPDS sample JCL to add the DSNFMT column. After the column has been added, run CBRPBIND. Consider setting DSNWITHSGNAME in the SETOAM statement in the CBROAMxx PARMLIB member. Review your ACS routines if appending the storage group name to OAM data set names (DSNWITHSGNAME).</li> <li>d. Make the needed changes to ACS routines for ALLOC, STORE and CTRANS environments.</li> </ol> </li> </ol>	Required	<p><i>z/OS DFSMS OAM Planning, Installation, and Storage Administration Guide for Object Support</i></p>

<b>System-level tasks</b>	<b>Condition</b>	<b>Procedure reference</b>
<p><i>DFSMSHsm tape environment</i></p> <p>DFSMSHsm allows the specification of tape unit names using either generic or esoteric names. Installations that have a mixture of non-SMS-managed 3590 devices defined under the 3590-1 generic name, need to perform these steps:</p> <ol style="list-style-type: none"> <li>1. Define a unique esoteric for each recording technology.</li> <li>2. Use the SETSYS USERUNITTABLE command to define these esoteric names to DFSMSHsm. This also applies to mixed devices in the 3490 generic. Installations that use SMS-managed tape devices or have a single 3590-1 recording technology, do not need to define an esoteric for those devices. However, if you have a mixed SMS-managed 3590 environment, please review APAR OW57282.</li> </ol>	Required	<ul style="list-style-type: none"> <li>• <i>z/OS DFSMSHsm Implementation and Customization Guide</i></li> <li>• <i>z/OS DFSMSHsm Storage Administration</i></li> </ul>
<p><i>Setting up DFSMSHsm to use WORM output tapes for ABACKUP</i></p> <p>In a SMS tape environment, and optionally in a non-SMS tape environment, the SMS data class construct can be used to select WORM tapes for ABACKUP processing. The output data set prefix specified in the aggregate group definition can be used by the ACS routines to select a WORM data class. Set up the ACS routine and the output data set name to uniquely identify the ABARS output files that must go to WORM tape.</p> <p>In a non-SMS tape environment, the default allows tape pooling to determine if ABARS data sets go to WORM or R/W media. Optionally, if the DEVSUP:xx parameter, ENFORCE_DC_MEDIA=ALLMEDIATY or ENFORCE_DC_MEDIA=MEDIA5PLUS, is used, then the data class must request the appropriate media type for it to be successfully mounted.</p>	Required	<ul style="list-style-type: none"> <li>• <i>z/OS DFSMSHsm Implementation and Customization Guide</i></li> <li>• <i>z/OS DFSMSHsm Storage Administration</i></li> </ul>
<b>Application-level tasks</b>	<b>Condition</b>	<b>Procedure reference</b>
<p>For programs that use dynamic allocation and cannot take advantage of predefined data class definitions, set the PARM for the DALINCHG text unit key in DALINCHG to specify the media type and recording technology for system-managed tape library allocations.</p>	Optional	<i>z/OS MVS Programming: Authorized Assembler Services Guide</i>





---

## Chapter 53. Access method services (AMS) modifications for 3592 Model J

This topic describes changes to the access method services (AMS) commands to support the 3592 Model J tape drives. These commands are changed.

- “ALTER LIBRARYENTRY”
- “ALTER VOLUMEENTRY” on page 363
- “CREATE LIBRARYENTRY” on page 366
- “CREATE VOLUMEENTRY” on page 369
- “DCOLLECT” on page 371
- “LISTCAT” on page 373

**Attention:** Use these AMS commands only to recover from tape volume catalog errors. Because AMS cannot change the library manager inventory in an automated tape library, use ISMF for normal tape library alter functions.

**Related reading:**

For explanations of all the parameters used with the AMS commands and additional examples, refer to *z/OS DFSMS Access Method Services Commands*.

---

### ALTER LIBRARYENTRY

Use the AMS ALTER LIBRARYENTRY command to modify the attributes for an existing tape library entry.

#### ALTER LIBRARYENTRY command syntax

The syntax for the AMS ALTER LIBRARYENTRY command is as follows.

Keyword	Opeands
ALTER	<i>entryname</i> <b>LIBRARYENTRY</b> [ <b>CONSOLENAME</b> ( <i>consolename</i> )] [ <b>DESCRIPTION</b> ( <i>desc</i> )] [ <b>LIBDEVTYPE</b> ( <i>devtype</i> )] [ <b>LIBRARYID</b> ( <i>libid</i> )] [ <b>LOGICALTYPE</b> { <b>AUTOMATED</b>   <b>MANUAL</b> }] [ <b>NULLIFY</b> ([ <b>LIBDEVTYPE</b> ][ <b>LOGICALTYPE</b> ])] [ <b>NUMBEREMPTYLOTS</b> ( <i>numslots</i> )] [ <b>NUMBERSCRATCHVOLUMES</b> ( <b>MEDIA1</b> ( <i>num</i> ) <b>MEDIA2</b> ( <i>num</i> ) <b>MEDIA3</b> ( <i>num</i> ) <b>MEDIA4</b> ( <i>num</i> ) <b>MEDIA5</b> ( <i>num</i> ) <b>MEDIA6</b> ( <i>num</i> ) <b>MEDIA7</b> ( <i>num</i> ) <b>MEDIA8</b> ( <i>num</i> ))] [ <b>NUMBERSLOTS</b> ( <i>numslots</i> )] [ <b>SCRATCHTHRESHOLD</b> ( <b>MEDIA1</b> ( <i>num</i> ) <b>MEDIA2</b> ( <i>num</i> ) <b>MEDIA3</b> ( <i>num</i> ) <b>MEDIA4</b> ( <i>num</i> ) <b>MEDIA5</b> ( <i>num</i> ) <b>MEDIA6</b> ( <i>num</i> ) <b>MEDIA7</b> ( <i>num</i> ) <b>MEDIA8</b> ( <i>num</i> ))] 

#### ALTER LIBRARYENTRY parameters

The **NUMBERSCRATCHVOLUMES** parameter and the **SCRATCHTHRESHOLD** parameter include the **MEDIA5**, **MEDIA6**, **MEDIA7**, and **MEDIA8** subparameters for the IBM System Storage family of tape media.

**[NUMBERSCRATCHVOLUMES(MEDIA1(num) MEDIA2(num) MEDIA3(num) MEDIA4(num) MEDIA5(num) MEDIA6(num) MEDIA7(num) MEDIA8(num))]**

Identifies the total number of MEDIA1, MEDIA2, MEDIA3, MEDIA4, MEDIA5, MEDIA6, MEDIA7, and MEDIA8 scratch volumes currently available in the given tape library.

**MEDIA1(num)**

The number of Cartridge System Tape scratch volumes available. Use a number from 0 to 999999. The default is 0.

**MEDIA2(num)**

Specifies the number of Enhanced Capacity Cartridge System Tape scratch volumes available. Use a number from 0 to 999999. The default is 0.

**MEDIA3(num)**

The number of High Performance Cartridge Tape scratch volumes available. Use a number from 0 to 999999. The default is 0.

**MEDIA4(num)**

Specifies the number of IBM Extended High Performance Cartridge Tape scratch volumes available. Use a number from 0 to 999999. The default is 0.

**MEDIA5(num)**

Specifies the number of IBM TotalStorage Enterprise Tape Cartridge scratch volumes available. Use a number from 0 to 999999. The default is 0.

**MEDIA6(num)**

Specifies the number of IBM TotalStorage Enterprise WORM Tape Cartridge scratch volumes available. Use a number from 0 to 999999. The default is 0.

**MEDIA7(num)**

Specifies the number of IBM TotalStorage Enterprise Economy Tape Cartridge scratch volumes available. Use a number from 0 to 999999. The default is 0.

**MEDIA8(num)**

Specifies the number of IBM TotalStorage Enterprise Economy WORM Tape Cartridge scratch volumes available. Use a number from 0 to 999999. The default is 0.

**Abbreviation:** NUMSCRV

**[SCRATCHTHRESHOLD(MEDIA1(num) MEDIA2(num) MEDIA3(num) MEDIA4(num) MEDIA5(num) MEDIA6(num) MEDIA7(num) MEDIA8(num))]**

Identifies the scratch volume message threshold. When the number of scratch volumes in the tape library falls below the scratch threshold, an operator action message, requesting that scratch volumes be entered into the tape library, is issued to the library's console. When the number of scratch volumes exceeds twice the scratch threshold, the message is removed from the console.

**MEDIA1(num)**

Specifies the threshold number of Cartridge System Tape scratch volumes. Use a number from 0 to 999999. The default is 0.

**MEDIA2(num)**

Specifies the threshold number of Enhanced Capacity System Tape scratch volumes. Use a number from 0 to 999999. The default is 0.

**MEDIA3(num)**

Specifies the threshold number of High Performance Cartridge Tape scratch volumes. Use a number from 0 to 999999. The default is 0.

**MEDIA4(num)**

Specifies the threshold number of IBM Extended High Performance Cartridge Tape scratch volumes. Use a number from 0 to 999999. The default is 0.

**MEDIA5(num)**

Specifies the threshold number of IBM TotalStorage Enterprise Tape Cartridge scratch volumes. Use a number from 0 to 999999. The default is 0.

**MEDIA6(num)**

Specifies the threshold number of IBM TotalStorage Enterprise WORM Tape Cartridge scratch volumes. Use a number from 0 to 999999. The default is 0.

**MEDIA7(num)**

Specifies the threshold number of IBM TotalStorage Enterprise Economy Tape Cartridge scratch volumes. Use a number from 0 to 999999. The default is 0.

**MEDIA8(num)**

Specifies the threshold number of IBM TotalStorage Enterprise Economy WORM Tape Cartridge scratch volumes. Use a number from 0 to 999999. The default is 0.

**Abbreviation:** SCRTHR

## Altering a tape library entry example

This example alters the entry for the tape library ATLLIB1.

```
//ALTERLIB JOB ...
//STEP1 EXEC PGM=IDCAMS
//SYSPRINT DD SYSOUT=A
//SYSIN DD *
ALTER ATLLIB1 -
LIBRARYENTRY -
NUMBEREMPTYSLOTS(2574) -
NUMBERSCRATCHVOLUMES(MEDIA6(500) MEDIA2(400)) -
SCRATCHTHRESHOLD(MEDIA6(200) MEDIA2(100))

/*
```

This command has these parameters:

- ATLLIB1 is the name of the entry being altered.
- LIBRARYENTRY alters a tape library entry.
- NUMBEREMPTYSLOTS sets the number of empty slots to 2574.
- NUMBERSCRATCHVOLUMES sets the current number of scratch volumes available for MEDIA6 to 500 and for MEDIA2 to 400.
- SCRATCHTHRESHOLD sets the threshold number of scratch volumes for MEDIA6 to 200 and for MEDIA2 to 100.

---

## ALTER VOLUMEENTRY

Use the AMS ALTER VOLUMEENTRY command to modify the attributes for an existing tape volume entry.

## ALTER VOLUMEENTRY command syntax

The syntax of the ALTER VOLUMEENTRY command is as follows:

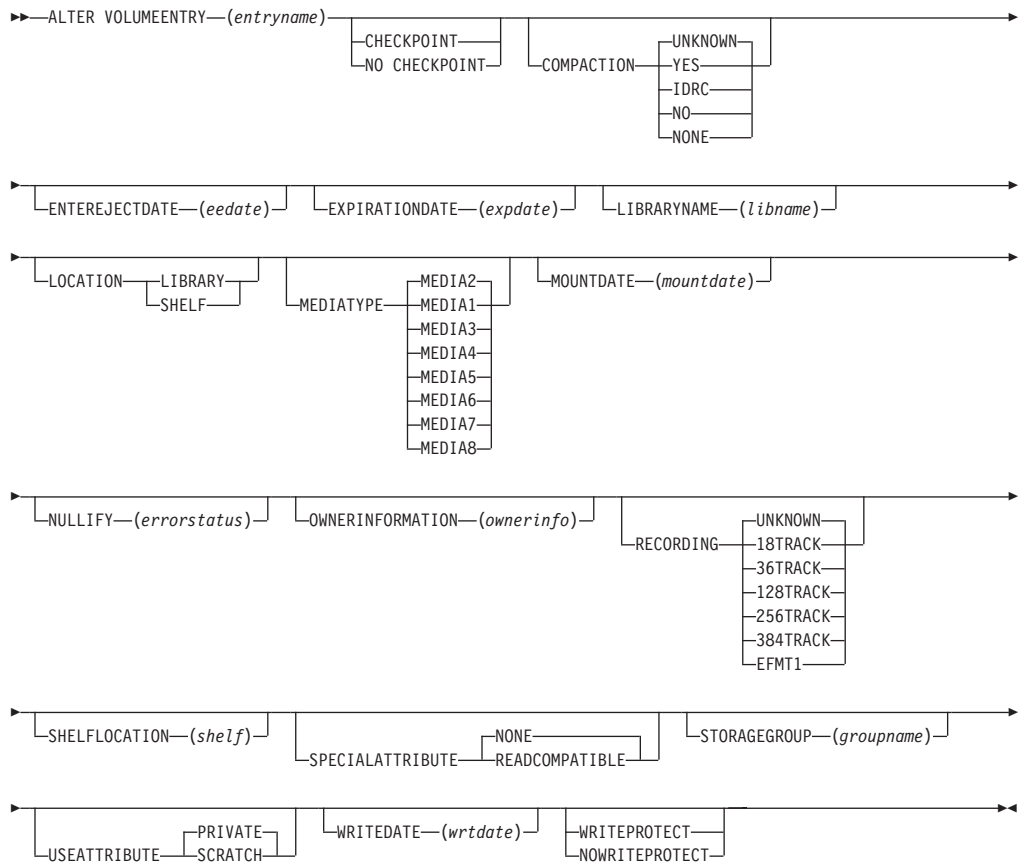

## ALTER VOLUMEENTRY parameters

**MEDIATYPE** and **RECORDING** are optional parameters. The **MEDIATYPE** and the **RECORDING** parameter include the subparameters **MEDIA5**, **MEDIA6**, **MEDIA7**, **MEDIA8**, and **EFMT1** for the 3592 Model J tape drive.

**MEDIATYPE**{ **MEDIA1** | **MEDIA2** | **MEDIA3** | **MEDIA4** | **MEDIA5** | **MEDIA6** | **MEDIA7** | **MEDIA8**}

Identifies the media type of the tape volume. If you do not use this, **MEDIATYPE** defaults to **MEDIA2**.

### **MEDIA1**

Specifies that the tape volume is Cartridge System Tape.

### **MEDIA2**

Specifies that the tape volume is Enhanced Capacity System Tape. You cannot use this parameter when **SPECIALATTRIBUTE** is **READCOMPATIBLE** or when **RECORDING** is set to **18TRACK**.

### **MEDIA3**

Specifies that the tape volume is High Performance Cartridge Tape.

### **MEDIA4**

Specifies that the tape volume is IBM Extended High Performance Cartridge Tape.

### **MEDIA5**

Specifies that the volume is IBM TotalStorage Enterprise Tape Cartridge.

**MEDIA6**

Specifies that the volume is IBM TotalStorage Enterprise WORM Tape Cartridge.

**MEDIA7**

Specifies that the volume is IBM TotalStorage Enterprise Economy Tape Cartridge.

**MEDIA8**

Specifies that the volume is IBM TotalStorage Enterprise Economy WORM Tape Cartridge.

**Abbreviation:** MTYPE

**[RECORDING{18TRACK|36TRACK|128TRACK| 256TRACK|384TRACK|EFMT1|UNKNOWN}]**

Identifies the tape recording technology. This parameter can be used for private tape volumes only. The default for scratch tape volumes is UNKNOWN.

**18TRACK**

Tape was written on an 18-track device and must be read on an 18-track device or a 36-track device.

**36TRACK**

Tape was written and must be read on a 36-track device.

**128TRACK**

Tape was written on a 128-track device and must be read on a 128-track, 256-track, or 384-track device.

**256TRACK**

Tape was written on a 256-track device and must be read on a 256-track device or a 384-track device.

**Note:** 128TRACK and 256TRACK are valid with **MEDIATYPE(MEDIA3)** or **MEDIATYPE(MEDIA4)** only.

**384TRACK**

Tape was written and must be read on a 384-track device.

**Note:** 384TRACK is valid with **MEDIATYPE(MEDIA3)** or **MEDIATYPE(MEDIA4)** only.

**EFMT1**

Tape was written and must be read on an EFMT1 (enterprise format 1) device.

**Note:** EFMT1 is valid with **MEDIATYPE(MEDIA5)**, **(MEDIA6)**, **(MEDIA7)**, and **(MEDIA8)** only.

**UNKNOWN**

Tape recording technology is unknown. This is the default value for scratch tape volumes.

**Abbreviation:** REC

## Altering a volume entry example

This example of the ALTER VOLUMEENTRY command alters the entry name that describes volume 0A2991.

```

//ALTEVOL JOB ...
//STEP1 EXEC PGM=IDCAMS
//SYSPRINT DD SYSOUT=A
//SYSIN DD *
ALTER VOLUMEENTRY(V0A2991)-
LIBRARYNAME(ATLIB02)-
USEATTRIBUTE(SCRATCH)-
MEDIATYPE(MEDIA6)-
RECORDING(EFMT1)

```

The parameters that are used in this example are as follows:

- ALTER VOLUMEENTRY indicates that an entry that describes a single volume in a library is being altered.
- V0A2991 specifies that the name of the volume being altered is V0A2991 and that the *volser* is 0A2991.
- LIBRARYNAME specifies that the name of the library with which this volume record is associated is ATLIB02.
- USEATTRIBUTE identifies the volume as being a SCRATCH tape.
- MEDIATYPE specifies the media type as MEDIA6.
- RECORDING specifies the recording technology as EFMT1.

## CREATE LIBRARYENTRY

Use the AMS CREATE LIBRARYENTRY command to create a tape library entry. Use it only to recover from tape volume catalog errors.

### CREATE LIBRARYENTRY command syntax

The syntax for the CREATE LIBRARY command is:

Keyword	Operands
CREATE	<b>LIBRARYENTRY</b> (NAME( <i>entryname</i> ) LIBRARYID( <i>libid</i> ) [CONSOLENAME( <i>consolename</i> )] [DESCRIPTION( <i>desc</i> )] [LIBDEVTYPE( <i>devtype</i> )] [LOGICALTYPE{AUTOMATED   MANUAL}] [NUMBEREMPTYLOTS( <i>numslots</i> ): [NUMBERSCRATCHVOLUMES(MEDIA1( <i>num</i> ) MEDIA2( <i>num</i> ) MEDIA3( <i>num</i> ) MEDIA4( <i>num</i> ) MEDIA5( <i>num</i> ) MEDIA6( <i>num</i> ) MEDIA7( <i>num</i> ) MEDIA8( <i>num</i> ))] ) [NUMBERSLOTS( <i>numslots</i> )] [SCRATCHTHRESHOLD(MEDIA1( <i>num</i> ) MEDIA2( <i>num</i> ) MEDIA3( <i>num</i> ) MEDIA4( <i>num</i> ) MEDIA5( <i>num</i> ) MEDIA6( <i>num</i> ) MEDIA7( <i>num</i> ) MEDIA8( <i>num</i> ))] )

### CREATE LIBRARYENTRY parameters

The NUMBERSCRATCHVOLUMES parameter and the SCRATCHTHRESHOLD parameter include the MEDIA5, MEDIA6, MEDIA7, and MEDIA8 subparameters for the IBM System Storage family of tape media.

**[NUMBERSCRATCHVOLUMES(MEDIA1(*num*) MEDIA2(*num*) MEDIA3(*num*) MEDIA4(*num*)  
MEDIA5(*num*) MEDIA6(*num*) MEDIA7(*num*) MEDIA8(*num*))]**

Identifies the total number of MEDIA1, MEDIA2, MEDIA3, MEDIA4, and MEDIA5 scratch volumes currently available in the given tape library.

**MEDIA1(*num*)**

Is the number of Cartridge System Tape scratch volumes available. Use a number from 0 to 999999. The default is 0.

**MEDIA2(*num*)**

Specifies the number of Enhanced Capacity Cartridge System Tape scratch volumes available. Use a number from 0 to 999999. The default is 0.

**MEDIA3(*num*)**

Is the number of High Performance Cartridge Tape scratch volumes available. Use a number from 0 to 999999. The default is 0.

**MEDIA4(*num*)**

Specifies the number of IBM Extended High Performance Cartridge Tape scratch volumes available. Use a number from 0 to 999999. The default is 0.

**MEDIA5(*num*)**

Specifies the number of IBM TotalStorage Enterprise Tape Cartridge scratch volumes available. Use a number from 0 to 999999. The default is 0.

**MEDIA6(*num*)**

Specifies the number of IBM TotalStorage Enterprise WORM Tape Cartridge scratch volumes available. Use a number from 0 to 999999. The default is 0.

**MEDIA7(*num*)**

Specifies the number of IBM TotalStorage Enterprise Economy Tape Cartridge scratch volumes available. Use a number from 0 to 999999. The default is 0.

**MEDIA8(*num*)**

Specifies the number of IBM TotalStorage Enterprise Economy WORM Tape Cartridge scratch volumes available. Use a number from 0 to 999999. The default is 0.

**Abbreviation:** NUMSCRV

**[SCRATCHTHRESHOLD(MEDIA1(*num*) MEDIA2(*num*) MEDIA3(*num*) MEDIA4(*num*)  
MEDIA5(*num*) MEDIA6(*num*) MEDIA7(*num*) MEDIA8(*num*))]**

Identifies the scratch volume message threshold. When the number of scratch volumes in the tape library falls below the scratch threshold, an operator action message, requesting that scratch volumes be entered into the tape library, is issued to the library console. When the number of scratch volumes exceeds twice the scratch threshold, the message is removed from the console.

**MEDIA1(*num*)**

Specifies the threshold number of Cartridge System Tape scratch volumes. Use a number from 0 to 999999. The default is 0.

**MEDIA2(*num*)**

Specifies the threshold number of Enhanced Capacity System Tape scratch volumes. Use a number from 0 to 999999. The default is 0.

**MEDIA3(*num*)**

Specifies the threshold number of High Performance Cartridge Tape scratch volumes. Use a number from 0 to 999999. The default is 0.

**MEDIA4(num)**

Specifies the threshold number of IBM Extended High Performance Cartridge Tape scratch volumes. Use a number from 0 to 999999. The default is 0.

**MEDIA5(num)**

Specifies the threshold number of IBM TotalStorage Enterprise Tape Cartridge scratch volumes. Use a number from 0 to 999999. The default is 0.

**MEDIA6(num)**

Specifies the threshold number of IBM TotalStorage Enterprise WORM Tape Cartridge scratch volumes. Use a number from 0 to 999999. The default is 0.

**MEDIA7(num)**

Specifies the threshold number of IBM TotalStorage Enterprise Economy Tape Cartridge scratch volumes. Use a number from 0 to 999999. The default is 0.

**MEDIA8(num)**

Specifies the threshold number of IBM TotalStorage Enterprise Economy WORM Tape Cartridge scratch volumes. Use a number from 0 to 999999. The default is 0.

**Abbreviation:** SCRTHR

## Creating a tape library entry example

The CREATE LIBRARYENTRY command can be used to perform functions shown in this example.

This example creates an entry for a tape library named ATLLIB1.

```
//CREATLIB JOB ...
//STEP1 EXEC PGM=IDCAMS
//SYSPRINT DD SYSOUT=A
//SYSIN DD *
CREATE LIBRARYENTRY -
  (NAME(ATLLIB1) -
  LIBRARYID(12345) -
  LIBDEVTYPE(3494-L10) -
  LOGICALTYPE(AUTOMATED) -
  NUMBERSLOTS(15000) -
  NUMBEREMPTYLOTS(1000) -
  NUMBERSCRATCHVOLUMES(MEDIA6(500) MEDIA2(400)) -
  SCRATCHTHRESHOLD(MEDIA6(200) MEDIA2(100)) -
  DESCRIPTION('TEST LIBRARY ATLLIB1') -
  CONSOLENAME(TESTCON)

/*
```

The parameters are:

- LIBRARYENTRY creates an entry for a tape library.
- NAME names the tape library ATLLIB1.
- LIBRARYID is the tape library's five-digit hexadecimal serial number, 12345.
- LIBDEVTYPE indicates that the tape library device type is 3494-L10.
- LOGICALTYPE specifies that the tape library is automated.
- NUMBERSLOTS is the total number of slots available in this tape library, 15000.



- NUMBEREMPTYLOTS is the total number of empty slots currently available, 1000.
- NUMBERSCRATCHVOLUMES is the total number of MEDIA6 scratch volumes (500) and MEDIA2 scratch volumes (400).
- SCRATCHTHRESHOLD is the scratch volume threshold for MEDIA6 tape volumes (200) and MEDIA2 tape volumes is (100). When the number of available scratch volumes decreases to these values, an operator action message is issued to the console.
- DESCRIPTION is the description of the tape library.
- CONSOLENAME specifies that TESTCON is the console name.

## CREATE VOLUMEENTRY

Use the AMS CREATE VOLUMEENTRY command to create tape volume entries.

### CREATE VOLUMEENTRY command syntax

The syntax of the CREATE VOLUMEENTRY command is as follows:

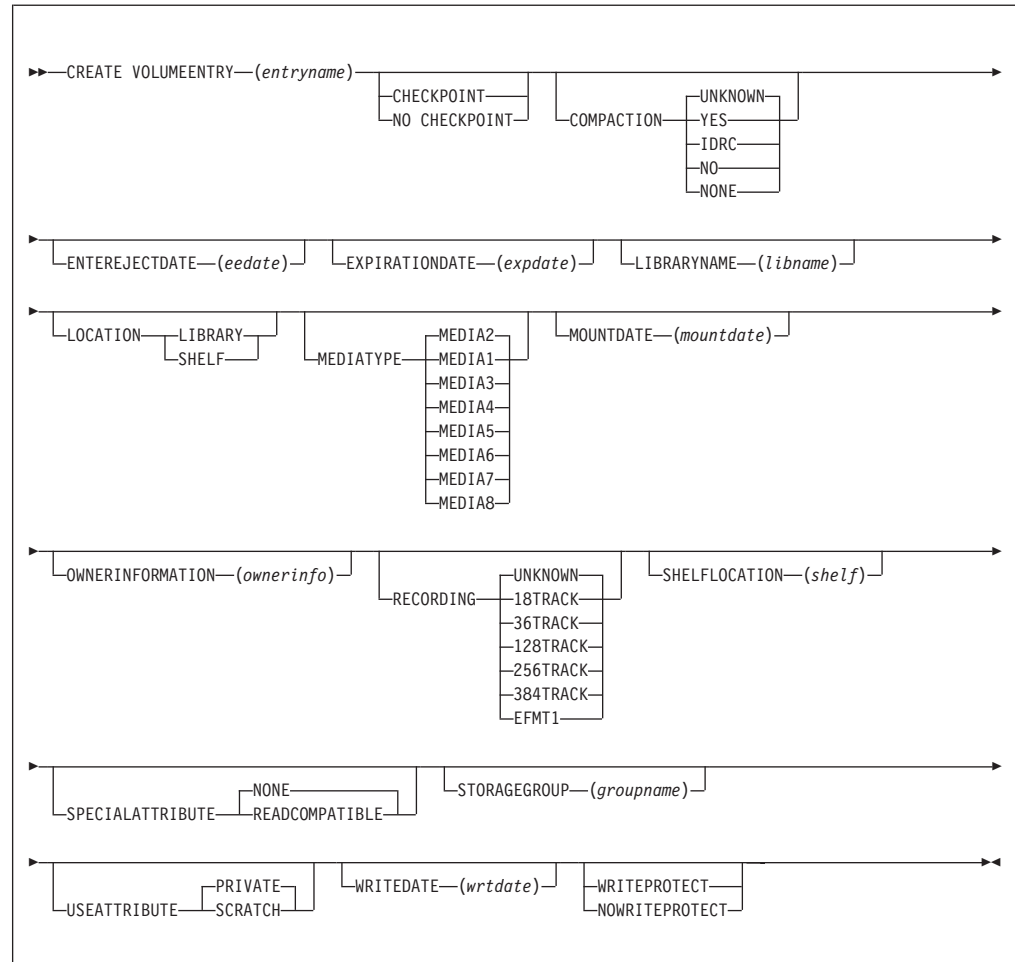

### CREATE VOLUMEENTRY parameters

**MEDIATYPE** and **RECORDING** are optional parameters. The **MEDIATYPE** and the **RECORDING** parameter include subparameters **MEDIA5**, **MEDIA6**, **MEDIA7**, **MEDIA8**, and **EFMT1** for the 3592 Model J tape drive.

**MEDIATYPE{ MEDIA1|MEDIA2|MEDIA3|MEDIA4|MEDIA5|MEDIA6|MEDIA7|MEDIA8}**

Identifies the media type of the tape volume. If you do not use this, MEDIATYPE defaults to MEDIA2.

**MEDIA1**

Specifies that the tape volume is Cartridge System Tape.

**MEDIA2**

Specifies that the tape volume is Enhanced Capacity System Tape. You cannot use this parameter when SPECIALATTRIBUTE is READCOMPATIBLE, or RECORDING is set to 18TRACK.

**MEDIA3**

Specifies that the tape volume is High Performance Cartridge Tape.

**MEDIA4**

Specifies that the tape volume is IBM Extended High Performance Cartridge Tape.

**MEDIA5**

Specifies that the tape volume is IBM TotalStorage Enterprise Tape Cartridge.

**MEDIA6**

Specifies that the tape volume is IBM TotalStorage Enterprise WORM Tape Cartridge.

**MEDIA7**

Specifies that the tape volume is IBM TotalStorage Enterprise Economy Tape Cartridge.

**MEDIA8**

Specifies that the tape volume is IBM TotalStorage Enterprise Economy WORM Tape Cartridge.

**Abbreviation: MTYPE**

**[RECORDING{18TRACK|36TRACK|128TRACK| 256TRACK|384TRACK|EFMT1|UNKNOWN}]**

Identifies the tape recording technology. This parameter can be used for private tape volumes only. The default for scratch tape volumes is UNKNOWN.

**18TRACK**

Tape was written on an 18-track device and must be read on an 18-track device or a 36-track device.

**36TRACK**

Tape was written and must be read on a 36-track device.

**128TRACK**

Tape was written on a 128-track device and must be read on a 128-track, 256-track, or 384-track device.

**256TRACK**

Tape was written on a 256-track device and must be read on a 256-track device or a 384-track device.

**Note:** 128TRACK and 256TRACK are valid with MEDIATYPE(MEDIA3) or MEDIATYPE(MEDIA4) only.

**384TRACK**

Tape was written and must be read on a 384-track device.

**Note:** 384TRACK is valid with **MEDIATYPE(MEDIA3)** or **MEDIATYPE(MEDIA4)** only.

**EFMT1**

Tape was written and must be read on an EFMT1 (enterprise format 1) device.

**Note:** EFMT1 is valid with **MEDIATYPE(MEDIA5)**, **(MEDIA6)**, **(MEDIA7)**, and **(MEDIA8)** only.

**UNKNOWN**

Tape recording technology is unknown. This is the default value for scratch tape volumes.

**Abbreviation:** REC

## Creating a VOLUME entry example

This example of the CREATE VOLUMEENTRY command creates a volume entry for volume 0A2991.

```
//CREATVOL JOB ...
//STEP1 EXEC PGM=IDCAMS
//SYSPRINT DD SYSOUT=A
//SYSIN DD *
CREATE VOLUMEENTRY(V0A2991)-
LIBRARYNAME(ATLIB02)-
USEATTRIBUTE(SCRATCH)-
MEDIATYPE(MEDIA7)-
RECORDING(EFMT1)
```

The parameters used in this example are as follows:

- CREATE VOLUMEENTRY indicates that an entry describing a single volume in a library is being created.
- V0A2991 specifies that the name of the volume entry being created is V0A2991 and the *volser* is 0A2991.
- LIBRARYNAME specifies that the name of the library with which this volume record is associated is ATLIB02.
- USEATTRIBUTE identifies the volume as being a SCRATCH tape.
- MEDIATYPE specifies the media type as MEDIA7.
- RECORDING specifies the recording technology as EFMT1.

---

## DCOLLECT

The DFSMS Data Collection Facility (DCOLLECT) is a function of access method services. DCOLLECT collects data in a sequential file that you can use as input to other programs or applications.

### DCOLLECT command syntax

The syntax of the DCOLLECT command is as follows.

Keyword	Operands
DCOLLECT	{OUTFILE( <i>ddname</i> )   OUTDATASET( <i>entryname</i> )} {[VOLUMES( <i>volser</i> [ <i>volser</i> ...])] [BACKUPDATA]}

Keyword	Operands
	[CAPPLANDATA]
	[EXCLUDEVOLUMES( <i>volser</i> [ <i>volser</i> ...])]
	[MIGRATEDATA]
	[SMSDATA(SCDSNAME( <i>entryname</i> )   ACTIVE)]
	[STORAGEGROUP( <i>sgname</i> [ <i>sgname</i> ...])]
	[DDCMEDIA{DDCMENUL   DDCMEDA1   DDCMEDA2   DDCMEDA3   DDCMEDA4   DDCMEDA5   DDCMEDA6   DDCMEDA7   DDCMEDA8}]
	[DDCRECTE{DDCRTNUL   DDC18TRK   DDC36TRK   DDC128TK   DDC256TK   DDC384TK   DDCEFMT1}]
	[ERRORLIMIT( <i>value</i> )]
	[EXITNAME( <i>entrypoint</i> )]
	[MIGRSNAPALL   MIGRSNAPERR]
	[NODATAINFO]
	[NOVOLUMEINFO]
	[REPLACE   APPEND]

## DCOLLECT parameters

The optional **DDCMEDIA** parameter and the optional **DDCRECTE** include subparameters for support of the 3592 Model J tape drive.

**DDCMEDIA (DDCMENUL | DDCMEDA1 | DDCMEDA2 | DDCMEDA3 | DDCMEDA4 | DDCMEDA5 | DDCMEDA6 | DDCMEDA7 | DDCMEDA8)**

shows the type and format of the cartridges used for mountable tape data sets used with this data class. It is mapped by one of these attributes:

### DDCMENUL

Media type is not specified (NULL). The constant value is 0.

### DDCMEDA1

Media type is MEDIA1 (cartridge system tape media). The constant value is 1.

### DDCMEDA2

Media type is MEDIA2 (enhanced capacity cartridge tape media). The constant value is 2.

### DDCMEDA3

Media type is MEDIA3 (high-performance cartridge tape media). The constant value is 3.

### DDCMEDA4

Media type is MEDIA4 (extended high-performance cartridge tape media). The constant value is 4.

### DDCMEDA5

Media type is MEDIA5 (Enterprise Tape Cartridge media). The constant value is 5.

### DDCMEDA6

Media type is MEDIA6 (Enterprise WORM Tape Cartridge media). The constant value is 6.

### DDCMEDA7

Media type is MEDIA7 (Enterprise Economy Tape Cartridge media). The constant value is 7.

### DDCMEDA8

Media type is MEDIA8 (Enterprise Economy WORM Tape Cartridge media). The constant value is 8.

### DDCRECTE

(DDCRTNUL|DDC18TRK|DDC36TRK|DDC128TK|DDC256TK |DDC384TK|DDCEFMT1)

indicates the number of recording tracks on the cartridge used for the mountable tape data sets associated with this data class.

### DDCRTNUL

The recording technology is not specified (NULL). The constant value is 0.

### DDC18TRK

The recording technology is 18TRACK. The constant value is 1.

### DDC36TRK

The recording technology is 36TRACK. The constant value is 2.

### DDC128TK

The recording technology is 128TRACK. The constant value is 3.

### DDC256TK

The recording technology is 256TRACK. The constant value is 4.

### DDC384TK

The recording technology is 384TRACK. The constant value is 5.

### DDCEFMT1

The recording technology is EFMT1. The constant value is 6.

## DCOLLECT example

Refer to *z/OS DFSMS Access Method Services Commands* for several examples of how to use the DCOLLECT function in a batch environment.

---

## LISTCAT

Use the AMS LISTCAT command to list catalog entries.

### LISTCAT command syntax

The syntax for the LISTCAT command remains the same but the output includes MEDIATYPE parameter values and RECORDING parameter values. The syntax is as follows:

Keyword	Operands
LISTCAT	[ALIAS] [ALTERNATEINDEX] [CLUSTER] [DATA] [GENERATIONDATAGROUP] [INDEX] [LIBRARYENTRIES( <i>libent</i> )] [NONVSAM] [PAGESPACE] [PATH] [USERCATALOG] [VOLUMEENTRIES( <i>volent</i> )] [CREATION( <i>days</i> )]

**Keyword Operands**

[ENTRIES(*entryname[/password][entryname[/password]...]*) | LEVEL(*level*)]  
 [EXPIRATION(*days*)]  
 [FILE(*ddname*)]  
 [LIBRARY(*libname*)]  
 [NAME | HISTORY | VOLUME | ALLOCATION | ALL]  
 [OUTFILE(*ddname*)]  
 [CATALOG(*catname*)]

**LISTCAT parameters**

The volume recording technology and media type are not parameters that can be specified with the LISTCAT command.

**List tape volume entries sample output**

The LISTCAT command displays the values for the RECORDING parameter and the MEDIATYPE parameter. For the 3592 Model J, the RECORDING parameter value is EFMT1 and the MEDIATYPE parameter can be MEDIA5, MEDIA6, MEDIA7, or MEDIA8. Figure 32 shows EFMT1 as the recording technology and MEDIA5 as the media type used for volume 0A2991.

This example of the LISTCAT command lists all volumes in the ATLIB02 library catalog. The command returns catalog data for only one volume with a volume *entryname* value of V0A2991.

```

LISTCAT -
  VOLUMEENTRIES
  ALL
IDCAMS SYSTEM SERVICES                TIME: 11:29:12      04/02/02      PAGE      2
                                LISTING FROM CATALOG -- SYS1.VOLCAT.V0
VOLUME-ENTRY---V0A2991
  DATA-VOLUME
  LIBRARY-----ATLIB02      RECORDING-----EFMT1      ERROR-STATUS-----NOERROR      CREATION-DATE-2002-04-02
                                MEDIA-TYPE-----MEDIA5      USE-ATTRIBUTE----SCRATCH      ENT-EJ-DATE----- (NULL)
  STORAGE-GROUP---*SCRCH+      COMPACTION----- (YES)
  CHECKPOINT----- (NULL)      SP-ATTRIBUTE-----NONE      WRITE-PROTECTED--- (NULL)      LAST-MOUNTED----- (NULL)
  LOCATION-----LIBRARY      SHELF-LOC----- (NULL)      LAST-WRITTEN----- (NULL)
  OWNER----- (NULL)      EXPIRATION----- (NULL)
IDCAMS SYSTEM SERVICES                TIME: 11:29:12      04/02/02      PAGE      3
                                LISTING FROM CATALOG -- SYS1.VOLCAT.VGENERAL
  THE NUMBER OF ENTRIES PROCESSED WAS:
    AIX -----0
    ALIAS -----0
    CLUSTER -----0
    DATA -----0
    GDG -----0
    INDEX -----0
    NONVSAM -----0
    PAGESPACE -----0
    PATH -----0
    SPACE -----0
    USERCATALOG -----0
    TAPELIBRARY -----0
    TAPEVOLUME -----1
    TOTAL -----1
  THE NUMBER OF PROTECTED ENTRIES SUPPRESSED WAS 0
IDC0001I FUNCTION COMPLETED, HIGHEST CONDITION CODE WAS 0
IDCAMS SYSTEM SERVICES                TIME: 11:29:12      04/02/02      PAGE      4
IDC0002I IDCAMS PROCESSING COMPLETE. MAXIMUM CONDITION CODE WAS 0

```

Figure 32. LISTCAT output

The parameters used in this example are as follows:

- VOLUMEENTRIES specifies that information relating to tape volume entries for all volumes in the library are to be listed.
- ALL requires that all information that is associated with the tape volume entries is to be listed.
- LIBRARY specifies that only tape volume entries that are associated with the tape library named ATLIB02 are to be listed.





---

## Chapter 54. Tape drive and tape volume allocation modifications for 3592 Model J

Changes made to device support, storage management subsystem (SMS), and Multiple Virtual Storage (MVS) device allocation enable you to allocate the tape drives and tape volumes. Within an IBM tape library environment, your system can fully recognize all supported media types and recording technologies. This topic explains these changes:

- “Device support modifications”
- “SMS modifications” on page 380
- “MVS device allocation modifications” on page 380

---

### Device support modifications

z/OS DFSMS device support provides hardware device-specific code, which allows tape drives, tape volumes, and DASD to interface with z/OS DFSMS. Specifically, it provides:

- The interfacing exits to the input/output supervisor (IOS) and EXCP device support code
- Error recovery procedure routines
- Services to acquire and log statistical and error data
- Services to acquire and display device states
- Utilities for functions like initializing tapes

You can use the MVS DEVSERV command to request basic status information on a device, a group of devices, or storage control units. You can use the QTAPE parameter of the DEVSERV command to display tape device information. Use DEVSERV QTAPE to display the real device type and the emulated device type.

With the DEVSERV QTAPE MED (medium) option, you can display information for the device type, media type, and cartridge volume serial number.

The syntax of the DEVSERV QTAPE command with the MED option is as follows:

**DS QT,xxxx,MED,nnn**

*xxxx*

Represents a three-digit or a four-digit device number in hexadecimal format.

*nnn*

Stands for the number of devices, starting at the address *xxxx*, for which the DEVSERV command displays the MED information. The value *nnn* is optional and can be any decimal number from 1 to 256, with 1 as the default value.

Figure 33 on page 378 shows the display content when you issue the DEVSERV QTAPE MED command.

```

-----
----      DS QT MED Display Content      ----
-----

IEE459I          DEVSERV QTAPE
UNIT RDTYPE EDTYPE EXVLSR INVLSR RMEDIA EMEDIA WWID X

```

Figure 33. DEVSERV QTAPE MED display content

- X UNIT - tape device address
- RDTYPE - real device type
- EDTYPE - emulated device type
- EXVLSR - external volume serial of cartridge
- INVLSR - internal volume serial of cartridge
- RMEDIA - real media type of the volume mounted on the drive
- EMEDIA - emulated media type of the volume mounted on the drive
- WWID - world-wide identifier or world-wide unique cartridge identifier

**Note:**

1. EDTYPE, EXVLSR, INVLSR, RMEDIA, EMEDIA, and WWID are blank if information is not available.
2. Valid values for RMEDIA and EMEDIA are:
  - 1=CST
  - 2=EC-CST
  - 3=3590 STD length tape
  - 4=3590 EXT length tape
  - 5=3592 Enterprise Tape Cartridge
  - 6-W=3592 Enterprise WORM Tape Cartridge
  - 7=3592 Enterprise Economy Tape Cartridge
  - 8-W=3592 Enterprise Economy WORM Tape Cartridge

RMEDIA and EMEDIA are blank when the media type is not defined or cannot be determined.

These examples show sample output and messages of the DEVSERV QTAPE command with the MED option.

Figure 34 shows the output of DS QT,962,MED when a 3592 Model J tape drive emulates a 3590 Model B1x tape drive.

```

IEE459I 11.32.31 DEVSERV QTAPE 608
UNIT RDTYPE EDTYPE EXVLSR INVLSR RMEDIA EMEDIA WWID
0962 3592-J 3590-1          6-W 3 85804D003C00000BC211CA0C

```

Figure 34. DS QT,962,MED output

Figure 35 shows the output of DS QT,940,MED when a 3592 Model J tape drive emulates a 3590 Model B1x tape drive.

```

IEE459I 11.32.31 DEVSERV QTAPE 608
UNIT RDTYPE EDTYPE EXVLSR INVLSR RMEDIA EMEDIA WWID
0940 3592-J 3590-1 003700          5 3

```

Figure 35. DS QT,940,MED output

Figure 36 shows the output of DS QT,DA0,MED when a 3592 Model J tape drive emulates a 3490 tape drive.

```
IEE459I 11.32.31 DEVSERV QTAPE 608
UNIT RDTYPE EDTYPE EXVLSR INVLSR RMEDIA EMEDIA WWID
0DA0 3592-J 3490 AN4000 5 1
```

Figure 36. DS QT,DA0,MED output

Figure 37 displays the message that is issued when the input device address is valid, but the device is not a Model B1x, Model E1x, Model H1x, 3592 Model J, or 3490E drive.

```
IEE459I 11.32.31 DEVSERV QTAPE 608
UNIT RDTYPE EDTYPE EXVLSR INVLSR RMEDIA EMEDIA WWID
**** UNLISTED DEVICE(S) AND REASON CODES :
0B60(10) Y
**** (10) - UNSUPPORTED DEVICE TYPE
```

Figure 37. DS QT,B60,MED message

**Y** Reason Code 10, UNSUPPORTED DEVICE TYPE, is shown when the device type given is not a Model B1x, Model E1x, Model H1x, 3592 Model J, or 3490E drive.

Figure 38 shows the message and reason code 11 that you receive if the input device address and device type are valid, but the device is not ready.

```
IEE459I 11.32.31 DEVSERV QTAPE 608
UNIT RDTYPE EDTYPE EXVLSR INVLSR RMEDIA EMEDIA WWID
**** UNLISTED DEVICE(S) AND REASON CODES :
0DA0(11) Z
**** (11) - DEVICE NOT READY
```

Figure 38. DS QT,DA0,MED message

A bit, DFVT3592, is added to the IHADFVT mapping macro that maps the data facilities vector table. If the enabling PTF for base 3592 and MEDIA5 is installed, DFVT3592 is set to indicate that all of the base software support for the 3592 Model J tape drive is on the system and supports the 3592 drive and MEDIA5.

A bit, DFVTWORM, is added to the IHADFVT mapping macro that maps the data facilities vector table. If the enabling PTF for the media types, MEDIA6, MEDIA7, and MEDIA8, is installed, DFVTWORM is set to indicate that all of the software support for 3592 WORM media types (MEDIA6 and MEDIA8) and economy R/W media type (MEDIA7) is on the system.

System-wide DEVSUPxx parmlib member options control and manage media type selection for Automatic Tape Library (ATL) partitioning: MEDIA5=xxxx, MEDIA6=xxxx, MEDIA7=xxxx, and MEDIA8=xxxx, where xxxx is a 4-digit hexadecimal category code.

The IECUCBCX mapping macro is changed to support the 3592 Model J tape drive. The EPI values are:

- X'10' --REAL3592\_EMUL3590

- X'11'--REAL3592\_EMUL3490

There are also these bits:

- UCBCX\_MAXBUFBLK is set if the device can report the maximum block size since the last synchronizing event.
- UCBCX\_FASTACC is set if the medium supports a fast access segment.
- UCBCX\_WORM is set if the device has WORM capability.

Additionally, the order of these two fields is reversed so that UCBCX\_VOLSEQ is now a two-byte field and UCBCXRS6 is now a four-byte fields.

The IECLGT mapping macro is changed to support the WORM media on the system. A bit, VLOG\_WORM, is set for WORM media. There are also these fields:

- VLOG\_WWID, a 12-byte hexadecimal medium world-wide identifier for WORM media that is unique for each tape cartridge and cannot be changed by a user command.
- VLOG\_WMCNT, a two-byte Volume Write Mount Count indicator of the number of mounts that have occurred for the WORM volume when logical blocks were written to the medium. This field can be updated during an OPEN/CLOSE sequence when no user data is written to the tape because tape labels can be rewritten.

---

## SMS modifications

SMS automates and centralizes storage management. It automatically assigns service requirements and attributes to data when that data is created. SMS configuration services validate, for example, the recording technology value that ISMF specifies in data class definitions.

In an IBM tape library environment (automated or manual), use ISMF to specify the:

- EFMT1 recording technology attribute
- Media type of MEDIA5, MEDIA6, MEDIA7, or MEDIA8
- Performance scaling option, if the media type is MEDIA5. Media types MEDIA6, MEDIA7, and MEDIA8 are not scalable.

The performance scaling option can also be specified and used outside of the system-managed tape library environment.

In support of the 3592 Model J tape drives, SMS configuration services are updated to validate the recording technology value and the media type value.

---

## MVS device allocation modifications

MVS device allocation helps prioritize and select tape drives to meet the needs of application programs or system functions. Batch (JCL) or dynamic (SVC99) allocation makes these device needs known to MVS device allocation. MVS device allocation selects the appropriate devices and serializes them for the requester to use. It can also request that appropriate volumes be mounted on the allocated devices. It accomplishes these tasks by interfacing with SMS, DEVSERV, OAM, MSGDISP, and other system components.

MVS device allocation currently supports multiple types of tape devices. Within an IBM tape library environment, MVS device allocation considers media types and recording technologies when allocating tape drives and tape volumes. The dynamic

allocation (SVC 99) volume interchange text unit (DALINCHG) allows you to specify EFMT1 for the recording technology and MEDIA5, MEDIA6, MEDIA7, or MEDIA8 for the media type. See Table 57 for DALINCHG parameter values.

*Table 57. Dynamic allocation (DALINCHG) parameter values for tape cartridge media types*

Parameter value	Media type	Recording technology
65	MEDIA5	EFMT1
05	MEDIA5	No format
66	MEDIA6	EFMT1
06	MEDIA6	No format
67	MEDIA7	EFMT1
07	MEDIA7	No format
68	MEDIA8	EFMT1
08	MEDIA8	No format

**Related reading:**

- See *z/OS MVS System Commands* for more information on the DEVSERV QTAPE command.
- See Chapter 55, “ISMF modifications for 3592 Model J,” on page 383 for more information on the ISMF panel changes.
- See *z/OS MVS Programming: Authorized Assembler Services Guide* for more information about the DALINCHG parameter.
- See *z/OS DFSMS Installation Exits* for more information about the IECUCBCX mapping macro.



---

## Chapter 55. ISMF modifications for 3592 Model J

The interactive storage management facility (ISMF) provides a series of applications for storage administrators to define and manage SMS configurations. This topic describes changes to the data class application, the mountable tape volume application, and the tape library management application to support the 3592 Model J tape drive.

### Related reading:

- See *z/OS DFSMS OAM Planning, Installation, and Storage Administration Guide for Tape Libraries* for additional information on the ISMF tape library management application.
- See *z/OS DFSMSdfp Storage Administration* for additional information about data classes and the ISMF data class panels.

---

### Data class define and alter panels for 3592 Model J

A data class is a set of data set allocation attributes and associated values. You can define, alter, display, and list a data class by using the ISMF data class define/alter panel. The data class define/alter panel has changed to support the 3592 Model J tape drives as follows:

- You can specify the E1 value for the recording technology attribute EFMT1.
- You can specify 5 as the value for the MEDIA5 media type attribute, 6 as the value for the MEDIA6 media type attribute, 7 as the value for the MEDIA7 media type attribute, or 8 as the value for the MEDIA8 media type attribute.
- You can specify performance scaling to obtain faster access to data on MEDIA5 media only. Media types MEDIA6, MEDIA7, and MEDIA8 are not scalable.

---

### Mountable tape volume list panel

The mountable tape volume application enables you to create, save, and restore lists of tape cartridge volumes. It generates lists of mountable tape volumes and their characteristics that are based on the criteria you specify. MEDIA5, MEDIA6, MEDIA7, or MEDIA8 appears in column 8, MEDIA TYPE. EFMT1 appears in column 9, RECORDING TECHNOLOGY.

---

### Tape library management panels

The tape library management application allows you to define, alter, list and display tape libraries. These panels have been changed to support the 3592 Model J tape drives.

- A Scratch Threshold field for media types MEDIA5, MEDIA6, MEDIA7, and MEDIA8 is available on the TAPE LIBRARY DEFINE panel.
- A Scratch Threshold field for media types MEDIA5, MEDIA6, MEDIA7, and MEDIA8 is available on the TAPE LIBRARY ALTER/REDEFINE panel.
- A Scratch Threshold and Scratch Number field for media types MEDIA5, MEDIA6, MEDIA7, and MEDIA8 is available on the TAPE LIBRARY DISPLAY panel.
- On the TAPE LIBRARY LIST panel, these columns are available:
  - Two columns, MEDIA5 Scratch Number (column 20) and MEDIA5 Scratch Threshold (column 21).

- Two columns, MEDIA6 Scratch Number (column 22) and MEDIA6 Scratch Threshold (column 23).
- Two columns, MEDIA7 Scratch Number (column 24) and MEDIA7 Scratch Threshold (column 25).
- Two columns, MEDIA8 Scratch Number (column 26) and MEDIA6 Scratch Threshold (column 27).
- Pre-existing columns, 22, 23, and 24, are now columns 28, 29, and 30.
- On the TAPE LIBRARY PRINT ENTRY panel, these columns are available:
  - Two columns, MEDIA5 Scratch Number (column 20) and MEDIA5 Scratch Threshold (column 21).
  - Two columns, MEDIA6 Scratch Number (column 22) and MEDIA6 Scratch Threshold (column 23).
  - Two columns, MEDIA7 Scratch Number (column 24) and MEDIA7 Scratch Threshold (column 25).
  - Two columns, MEDIA8 Scratch Number (column 26) and MEDIA8 Scratch Threshold (column 27).
  - Pre-existing columns, 22, 23, and 24, are now columns 28, 29, and 30.
- On the TAPE LIBRARY SORT ENTRY panel, these columns are available:
  - Two columns, MEDIA5 Scratch Number (column 20) and MEDIA5 Scratch Threshold (column 21).
  - Two columns, MEDIA6 Scratch Number (column 22) and MEDIA6 Scratch Threshold (column 23).
  - Two columns, MEDIA7 Scratch Number (column 24) and MEDIA7 Scratch Threshold (column 25).
  - Two columns, MEDIA8 Scratch Number (column 26) and MEDIA8 Scratch Threshold (column 27).
  - Pre-existing columns, 22, 23, and 24, are now columns 28, 29, and 30.
- On the TAPE LIBRARY VIEW ENTRY panel, these columns are available:
  - Two items, MEDIA5 Scratch Number (column 20) and MEDIA5 Scratch Threshold (column 21).
  - Two columns, MEDIA6 Scratch Number (column 22) and MEDIA6 Scratch Threshold (column 23).
  - Two columns, MEDIA7 Scratch Number (column 24) and MEDIA7 Scratch Threshold (column 25).
  - Two columns, MEDIA8 Scratch Number (column 26) and MEDIA8 Scratch Threshold (column 27).
  - Pre-existing columns, 22, 23, and 24, are now columns 28, 29, and 30.



---

## Chapter 56. OCE modifications for 3592 Model J

The z/OS DFSMS Open/Close/End-of-Volume (OCE) component is a set of system routines that builds the control block structure that connects the application, access method, and the operating system. OCE modifications include passing the media type and recording technology to DFSMS, DFSMSrmm, OAM/Library Automation Communication Services, and to the tape installation exits. OCE changes also include commands to scale the MEDIA5 cartridge either for performance or for full capacity and then to ensure that the same scaling factor persists across all volumes of a multivolume data set. During CLOSE of file sequence 1 on a performance scaled cartridge, performance scaling is externalized as an addition to message IEC205I.

To make stand-alone tape mount processing consistent with SMS tape, two system-wide parmlib member DEVSUPxx options are added to ensure data class media policy is enforced for stand-alone, non-specific mounts:

- ENFORCE\_DC\_MEDIA=ALLMEDIATY
- ENFORCE\_DC\_MEDIA= MEDIA5PLUS

Also, a new system-wide, parmlib member DEVSUPxx option for MTL (Manual Tape Library), non-specific mounts is added:

- DEVSUP keyword: MTL\_NO\_DC\_WORM\_OK

OCE detects new OPEN and EOVS abends for WORM support when write violations are detected:

- IEC147I, return code 80, abend613
- IEC147I, return code 84, abend613
- IEC026I, return code A8, abend637
- IEC026I, return code AC, abend637

The OCE routines also include the IFGTEP macro with several fields for mapping installation exit parameter lists. Values that can be returned are: EFMT1 in TEPMRECTK recording technology and MEDIA5, MEDIA6, MEDIA7, or MEDIA8 in TEPMMEDT media type, as shown in Table 58 on page 387.

### Related reading:

- See *z/OS DFSMS Using Data Sets* and *z/OS DFSMS Using Magnetic Tapes* for additional information about the OCE routines.
- See *z/OS DFSMS Installation Exits* for more information on OCE installation exit parameter lists.
- See *z/OS DFSMS OAM Planning, Installation, and Storage Administration Guide for Tape Libraries* for more information on tape volume records.

---

## SMS-managed tape configuration database (TCDB) volume record

The OPEN and EOVS routines update the SMS-managed TCDB volume records with an indicator for the EFMT1 recording technology.

---

## SMS-managed tape (TVR) volume record

The OPEN and EOVS routines update the SMS-managed TVR volume records with the media type when opened for output to the first file.

---

## DEVSUP<sub>xx</sub> parmlib member options

System-wide DEVSUP<sub>xx</sub> parmlib member options are included to control and manage media type selection for:

- Stand-alone environment:
  - ENFORCE\_DC\_MEDIA=ALLMEDIATY ensures data class media policies are enforced for all stand-alone, non-specific mounts.
  - ENFORCE\_DC\_MEDIA=MEDIA5PLUS ensures data class media policies are enforced for all stand-alone, non-specific mounts for any of the four 3592 tape cartridge media types.

**Note:** The ENFORCE\_DC\_MEDIA option can be used in conjunction with the tape management systems pooling support to ensure that the correct media type is mounted. Before setting this option, determine how data class is used in the stand-alone environment to ensure that a data class with the correct media type specification is selected and that any tape management system pool assigned to the allocation request matches the media type specified in the assigned data class.

- Manual Tape Library (MTL) non-specific volume requests:
  - MTL\_NO\_DC\_WORM\_OK indicates that the installation is managing WORM media allocations through the tape management system pooling support, instead of data class. This option results in OPEN accepting MTL WORM scratch mounts when no media type is identified via data class.
- Automatic Tape Library (ATL) partitioning:
  - MEDIA5=*xxxx*
  - MEDIA6=*xxxx*
  - MEDIA7=*xxxx*
  - MEDIA8=*xxxx*

where *xxxx* is a 4-digit hexadecimal category code.

---

## Open/EOV Volume Security and Verification Exit

This user exit provides additional volume verification. A new WORM tape mount indicator in the Volume Security and Verification Exit (type X'18' in the DCB exit) identifies the exit. A parameter list pointer in reg1 is passed. The parameter list is mapped by the IEVCOEVSE macro. A new bit flag (x'40') is added to byte OEVSFLG: OEVSWORM X'40' - WORM tape mounted.

---

## IFGTEP macro

The IFGTEP macro maps the main and function-specific parameter lists for all OCE tape management exits. The IFGTEP macro has several fields that map the installation exit parameter lists. These fields are initialized for both SMS and non-SMS tapes.

Table 58 on page 387 describes the IFGTEP fields for mapping the installation exit main parameter list.

Table 58. IFGTEP fields for the installation exit main parameter list

Offset	Length or bit pattern	Field name	Description
31 (X'1F')	8	TEPMRECTK	Recording technology: 0=unknown 1=18TRK 2=36TRK 3=128TRK 4=256TRK 5=384TRK 6=EFMT1
34 (X'22')	8	TEPMMEDT	Media type: 1=Media1 2=Media2 3=Media3 4=Media4 5=Media5 6=Media6 7=Media7 8=Media8

## OCE Tape Installation Exits

The IFGTEP macro maps the tape log data. Table 59 describes the IFGTEP fields for mapping the installation exit main parameter list.

Table 59. IFGTEP fields for the installation exit main parameter list

Field name	Length or bit pattern	Description
TEPMWWID	CHAR(12)	WORM world-wide identifier
TEPMWMC	CHAR(2)	WORM tape cartridge media mounted, data written. This is passed in the tape installation main parameter list exit for WORM mounts to all exits.
TEPMWORM	BIT(1)	WORM tape cartridge media mounted



---

## Chapter 57. DFSMSHsm modifications for 3592 Model J

DFSMS hierarchical storage manager (DFSMSHsm), a z/OS functional component, automatically manages low activity and inactive data in both system-managed and non-system-managed environments. DFSMSHsm also provides automatic backup and recovery of active data in the same environments.

This topic describes specific changes to DFSMSHsm support for the 3592 Model J tape drives. These changes are as follows:

- Output tape selection
- Output tape utilization
- Reuse capacity table
- WORM tape cartridge rejection at OPEN time
- Aggregate backup and recovery (ABARs) with WORM tape cartridge

### Related reading:

- See *z/OS DFSMSdftp Storage Administration* for additional information on the SETSYS command.
- See *z/OS DFSMSHsm Implementation and Customization Guide* for additional information about implementing DFSMSHsm tape environments.

---

### Output tape selection

DFSMSHsm selects 3592 Model J tape drives for output in SMS and non-SMS tape environments. DFSMSHsm performs all its allocation requests by using these standard dynamic allocation interfaces:

- **Non-SMS-managed output tape selection:** If multiple types of tape drives are installed that emulate the 3590 device type, you must define an esoteric name for each model that DFSMSHsm uses. You must then define the esoteric names to DFSMSHsm by using the SETSYS `USERUNITTABLE(esoteric1:esoteric1,esoteric2:esoteric2,...)` command. You must also specify the esoteric names as the unit names for the desired DFSMSHsm functions. If a single type of tape drive is installed that emulates the 3590 device type, you do not have to define an esoteric name; instead, you can specify the 3590-1 generic name for the desired DFSMSHsm functions.
- **SMS-managed output tape selection:** DFSMSHsm performs a non-specific allocation; it then finds an acceptable output tape for the already allocated drive. If the 3590-1 generic name is used with multiple types of tape drives emulating the 3590 device type, see APAR OW57282 for further instructions.

---

### Output tape utilization

DFSMSHsm writes to 97% of the capacity of MEDIA5, MEDIA6, MEDIA7, and MEDIA8 tapes unless otherwise specified by the installation. Other percentages can be specified using the SETSYS TAPEUTILIZATION command, depending on the particular needs of the installation. DFSMSHsm uses the reported cartridge type on the physical device to determine the tape's capacity.

---

## Reuse capacity table

The reuse capacity table supports MEDIA5 and MEDIA7 tape cartridges for 3592 Model J tape drives. DFSMSHsm uses the reuse capacity table to determine the tapes eligible for RECYCLE processing based on capacity for each media type. Each media type has separate reuse capacities for backup and migration.

---

## WORM tape cartridge rejection at OPEN time

DFSMSHsm examines the OEVSWORM field passed by OPEN/EOV processing. The bit is turned on by OPEN/EOV when a WORM tape cartridge has been mounted. If a WORM tape cartridge is mounted for any function other than ABACKUP or ARECOVER, DFSMSHsm returns to OPEN/EOV with RC08, resulting in ABEND913 RC34 and a failure of OPEN. DFSMSHsm fails the function and issues either message ARC0309I (for non-ABARs) or ARC6410E (for an ARECOVER ML2 tape).

---

## Aggregate backup and recovery (ABARs) with WORM tape cartridge

Output for LIST AGGREGATE(agname) has a field labeled WORM. If the version resides on WORM tape cartridge media, WORM=YES. If it does not reside on WORM tape cartridge media, WORM=NO.

---

## DFSMSHsm tips

Here are some tips you might find helpful when using DFSMSHsm with the 3592 Model J tape drives.

- If your installation has an excessive number of spanning data sets, consider specifying a larger value in the SETSYS TAPESPANSIZE command. A larger absolute value is needed to represent the same amount of unused capacity on a percentage basis when the tape has a larger total capacity. For example, if you allow 2% of unused tape to avoid tape spanning for a 3590-Hxx device using enhanced media, you specify a TAPESPANSIZE of 1200 MB. To allow 2% unused tape for a MEDIA5 tape on a 3592 Model J device (no performance scaling), you specify a TAPESPANSIZE of 6000 MB. All size calculations for scaled tapes are based upon the scaled size and not the unscaled size.
- If the speed of data access on MEDIA5 tape is more important than full use of capacity, consider using performance scaling. Performance scaling allows 60 GB of physical (and more logical) data on each tape and keeps all data sets closer together and closer to the initial tape load point. If you use performance scaling with the DFSMSHsm duplex function, be sure the original tape and the alternate tape both use performance scaling. Similarly make sure that Tapecopy input tapes and output tapes have the same performance scaling attributes.

**Note:** Performance scaling is not available on MEDIA6, MEDIA7, or MEDIA8 tape cartridge media.

- If your installation is using MEDIA5 tapes with performance scaling, consider using MEDIA7 tapes for high performance functions. The available MEDIA5 tapes could then be used to their full capacity.

DFSMSHsm recycle processing of 3592 tapes can take significantly longer than the recycle of smaller tapes because the amount of data moved at the same RECYCLEPERCENT can be much larger. Besides moving more data, the likelihood of a tape takeaway for recall processing increases with the number of data sets still remaining on the tape.

One option for controlling overall recycle run time is the `LIMIT(nnnn)` parameter of recycle. Recycle returns no more than the specified number of tapes to scratch during the current recycle run. Because recycle sorts the tapes based on the amount of valid data still on each volume, the tapes recycled require the least processing time.

Another option to consider is decreasing the `ML2RECYCLEPERCENT` parameter, the `RECYCLEPERCENT` parameter, or both. For example, if your installation uses performance scaling (60 GB) for ML2, and you would like to move no more than 6 GB of data when an ML2 tape is recycled, set `ML2RECYCLEPERCENT(10)`. If your installation uses full capacity (300 GB) for backup tapes and you would like to move no more than 6 GB of data when a backup tape is recycled, set `RECYCLEPERCENT( 2)`. These examples assume that the ML2 and Backup tapes in the installation are filled to capacity because the calculations are based upon the average fullness of marked full tapes on your system (the reuse capacity.)

To determine how much data your current recycle threshold implies, use the reuse capacity associated with the tapes. The current recycle threshold percent multiplied by the reuse capacity gives the maximum amount of data on any of the tapes when they are recycled.

While lowering the recycle threshold reduces recycle processing time and decreases the number of times each tape must be recycled, it may also increase the overall number of tapes needed in your installation. Also, if you have a mix of ML2 or Backup tape capacities in need of recycle processing, you may want to recycle tapes with the `RANGE` parameter and use the appropriate recycle threshold for the tape capacities in the range.

In an SMS tape environment, and optionally in a non-SMS tape environment, the SMS data class construct can be used to select WORM tapes for ABACKUP processing. The output data set prefix specified in the aggregate group definition can be used by the ACS routines to select a WORM data class. Set up the ACS routine and the output data set name to uniquely identify the ABARS output files that must go to WORM tape.

In a non-SMS tape environment, the default is to allow tape pooling to determine if ABARS data sets go to WORM or R/W media. Optionally, if the `DEVSUP` parameter `ENFORCE_DC_MEDIA=ALLMEDIATY` or `ENFORCE_DC_MEDIA=MEDIA5PLUS` is used, then the data class must request the appropriate media type for it to be successfully mounted.

- If your installation is running OS/390 V2R10 or higher, consider using the Fast Subsequent Migration function to reduce the need to RECYCLE these high-capacity tapes.
- If your installation is running z/OS V1R3 or higher in a Sysplex environment, consider using the Common Recall Queue to optimize mounts of migration tapes.
- `AUDIT MEDIACONTROLS` for a `FAILEDCREATE` situation usually only needs to look at the last few files on a tape. If it is available for your system level, make sure Audit APAR OA04419 is applied.
- To fully utilize MEDIA5 tapes, unless you have a specific need to run in 22-bit FBID mode, operate 3592 Model J tape drives emulating D/T3490 in 32-bit FBID mode. MEDIA6, MEDIA7, and MEDIA8 tapes cannot be used on a 3592 Model J emulating D/T3490. The 3592 Model J tape drive always operates in 32-bit FBID mode when it is emulating D/T3590.
- If you decide to change the performance scaling attribute for a particular function and partially full MEDIA5 tapes already exist, mark full the partial MEDIA5 tapes for that function. This is necessary because OPEN processing

carries over the performance scaling attribute from partial tapes to the next mounted empty tape as long as the tape is mounted under the same allocation. When the function runs the next time, it will need to mount an empty tape and the performance scaling change can take effect.



---

## Chapter 58. DFSMSrmm modifications for 3592 Model J

DFSMSrmm is a feature of z/OS. It manages all tape media, such as cartridge system tapes and 3420 reels, and other removable media that you define to it.

DFSMSrmm performs these functions to support the 3592 Model J tape drives:

- Records the recording technology, as appropriate
- Records the media type
- Manages WORM tapes

This topic describes the updates to these DFSMSrmm TSO subcommands:

- ADDVOLUME
- CHANGEVOLUME
- SEARCHVOLUME

It also lists the changed REXX variables of the TSO subcommand, API structured field introducers, and mapping macros fields.

### Related reading:

- See *z/OS DFSMSrmm Managing and Using Removable Media* for the complete syntax of the DFSMSrmm ADDVOLUME subcommand, the DFSMSrmm CHANGEVOLUME subcommand, the DFSMSrmm SEARCHVOLUME subcommand, DFSMSrmm return codes and reason codes, and REXX variables.
- See *z/OS DFSMSrmm Application Programming Interface* for further information about the DFSMSrmm API.
- See *z/OS DFSMSrmm Implementation and Customization Guide* for additional information about DFSMSrmm mapping macros.

---

## ADDVOLUME

The ADDVOLUME TSO subcommand adds volumes to the DFSMSrmm control data set. This diagram shows the syntax of the MEDIATYPE operand, the VENDOR operand, and the WWID operand for the ADDVOLUME TSO subcommand.

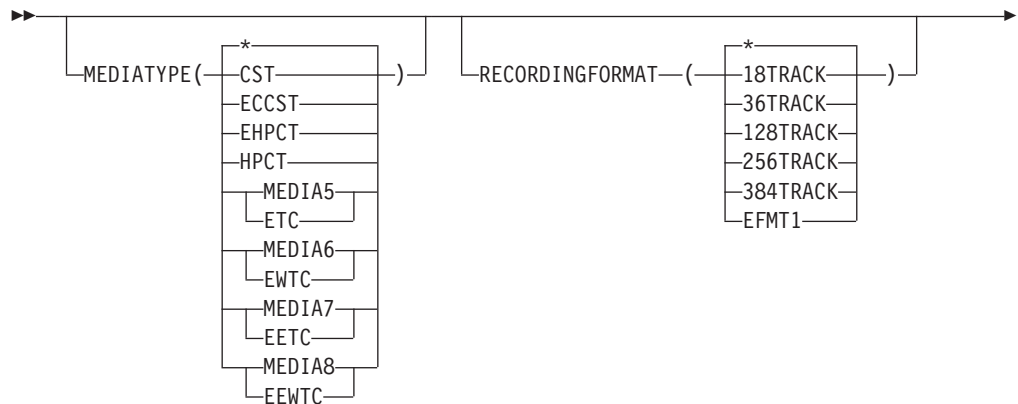

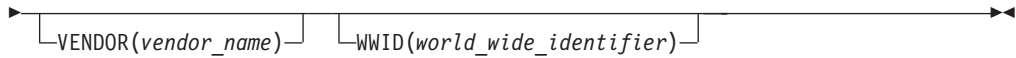

To use the EFMT1 recording technology, you must specify the MEDIATYPE(MEDIA5, MEDIA6, MEDIA7, or MEDIA8) operand of the ADDVOLUME TSO subcommand.

**Note:** DFSMSrmm uses its own media names for MEDIA1 through MEDIA4 and optionally uses its own media names for MEDIA5 through MEDIA8. DFSMSrmm uses these names in output for RMM LISTVOLUME subcommand requests and from any REXX EXECs you might have written. Table 60 lists these DFSMSrmm media names.

Table 60. DFSMSrmm media names

Media name	DFSMSrmm media name
MEDIA1	CST
MEDIA2	ECCST
MEDIA3	HPCT
MEDIA4	EHPCT
MEDIA5	ETC
MEDIA6	EWTC
MEDIA7	EETC
MEDIA8	EEWTC

## CHANGEVOLUME

The CHANGEVOLUME TSO subcommand updates details for a volume defined to DFSMSrmm. This diagram shows the syntax of the MEDIATYPE operand, the VENDOR operand, and the WWID operand for the CHANGEVOLUME TSO subcommand.

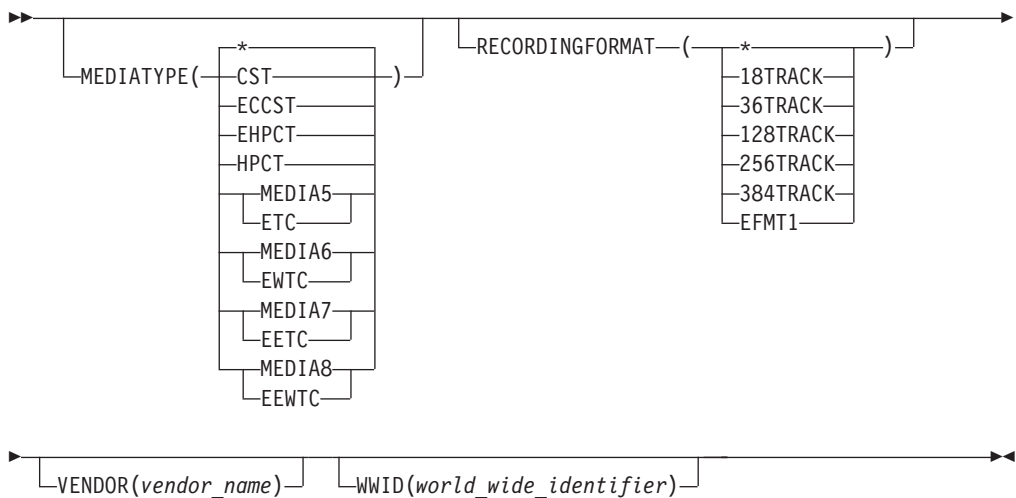

To use the EFMT1 recording technology, you must specify the MEDIATYPE(MEDIA5, MEDIA6, MEDIA7, or MEDIA8) operand of the CHANGEVOLUME TSO subcommand.

## SEARCHVOLUME

You can use the SEARCHVOLUME TSO subcommand to obtain a list of volumes that match selection criteria that you specify. Specify EFMT1 to limit your search to volumes that are written in the EFMT1 recording technology. You can also specify a particular media type, such as MEDIA5, to then further limit your search. Specify the VENDOR operand to limit your search to the manufacturer or supplier of the volume. This diagram shows the syntax of the MEDIATYPE operand and the VENDOR operand for the SEARCHVOLUME TSO subcommand.

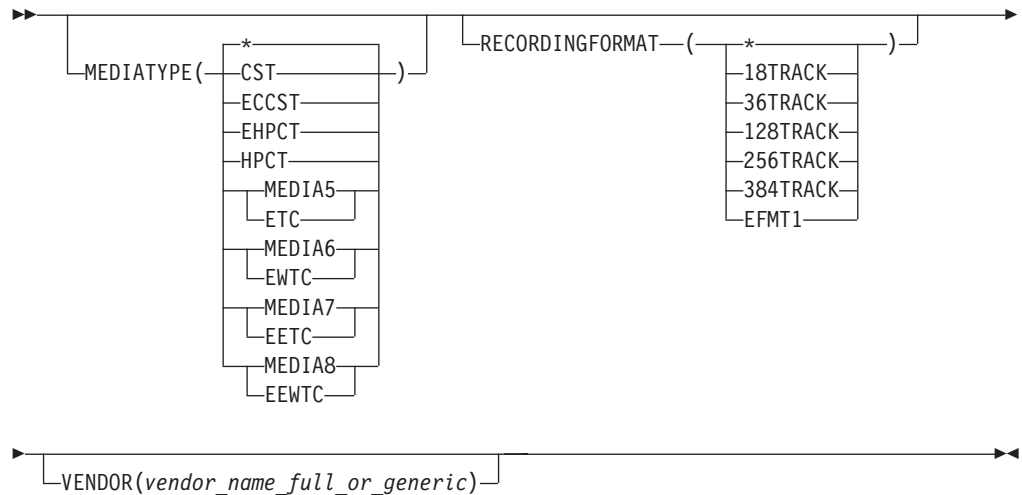

## DFSMSrmm REXX variables

You can use the REXX variables to obtain volume information. The variables produced by the SEARCHVOLUME subcommand are stem variables.

Table 61. Changed TSO subcommand REXX variables

Variable name	Subcommands	Contents	Format
EDG@MEDT	LV SV	Tape media type	One of *, CST, ECCST, EHPCT, HPCT, ETC, EWTC, EETC, and EEWTC
EDG@MOP	LC, LC VLPOOL (stem variable)	Masteroverwrite	One of ADD, MATCH, LAST, or USER
EDG@VNDR	LV VOL, SV(e)	Vendor information	8 alphanumeric or special characters
EDG@VWMC	LV STAT, SV(e)	Volume write mount count	Numeric: 0 - 99999
EDG@WWID	LV, SV(e)	World-wide identifier	24 hexadecimal characters

## DFSMSrmm structured field introducers

The DFSMSrmm application programming interface (API) returns data as structured fields in an output buffer that you define. Structured fields consist of a structured field introducer (SFI) and the data. SFIs describe the type, length, and other characteristics of the data.

Table 62 shows the structured field introducers that support 3592 Model J tape drives.

*Table 62. Changed structured field introducers*

Name	Number	Type	Length	Value	Subcommands
MEDT	X'858000'	Binary(8)	9	Media type: 0=UNDEFINED 1=CST 2=ECCST 3=HPCT 4=EHPCT 5=ETC/MEDIA5 6=EWTC/MEDIA6 7=EETC/MEDIA7 8=EEWTC/MEDIA8	LV, SV
VNDR	X'8B9E00'	Character(8)	16	Vendor information	LV VOL, SV (e)
VWMC	X'8B9100'	Binary(31)	12	Volume write mount count	LV STAT, SV (e)
WWID	X'8C4500'	Character(24)	32	World-wide identifier	LV, SV (e)
MOP	X'85C000'	Binary(8)	9	Master overwrite: 1=ADD 2=LAST 3=MATCH 4=USER	+LC VLPOOL (stem variable)

## DFSMSrmm macros

Table 63 shows the changes made to DFSMSrmm mapping macros for 3592 Model J tape drives.

*Table 63. DFSMSrmm mapping macro changes*

Mapping macro	Function	Updates
EDGEXTSY	Maps the extract data set symbols used with DFSORT	Media type values: ETC, EWTC, EETC, EEWTC, EFMT1 recording technology value, the WWID, write mount count, and tape vendor information
EDGRVEXT	Maps the volume records in the DFSMSrmm extract data set	Media type values: ETC, EWTC, EETC, EEWTC, EFMT1 recording technology value, the WWID, write mount count, and tape vendor information
EDGRXEXT	Maps the data set records in the DFSMSrmm extract data set	Media type values: ETC, EWTC, EETC, EEWTC, EFMT1 recording technology value, the WWID, write mount count, and tape vendor information
EDGSMFSY	Maps the SMF record symbols used with DFSORT	Media type values: ETC, EWTC, EETC, EEWTC, EFMT1 recording technology value, the WWID, write mount count, and tape vendor information
EDGSVREC	Maps the DFSMSrmm SMF volume records	Media type values: ETC, EWTC, EETC, EEWTC, EFMT1 recording technology value, the WWID, write mount count, and tape vendor information

## DFSMSrmm return codes and reason codes

Table 64 shows the return codes and reason codes introduced with the z/OS DFSMS software support for the 3592 Model J tape drives.

Table 64. New return codes and reason codes

Return Code	Reason Code	Issued
12	244	These codes are issued when an attempt to change the volume WWID is made.

## Parmlib Member EDGRMMxx VLPOOL MASTEROVERWRITE command

You use the parmlib member EDGRMMxx VLPOOL command to define pools and to set actions that you want taken on all the volumes that reside in the pool. The VLPOOL MASTEROVERWRITE operand controls how DFSMSrmm allows the overwriting of a volume. You can specify if you want to allow data to be appended to the end of a volume or overwritten, or to allow new files to be added to a volume. The MASTEROVERWRITE value applies to all volumes that reside in a pool. This diagram shows the syntax of the VLPOOL MASTEROVERWRITE operand.

If you do not specify the VLPOOL MASTEROVERWRITE value, DFSMSrmm uses the value that is set with the DFSMSrmm EDGRMMxx OPTION MASTEROVERWRITE operand.

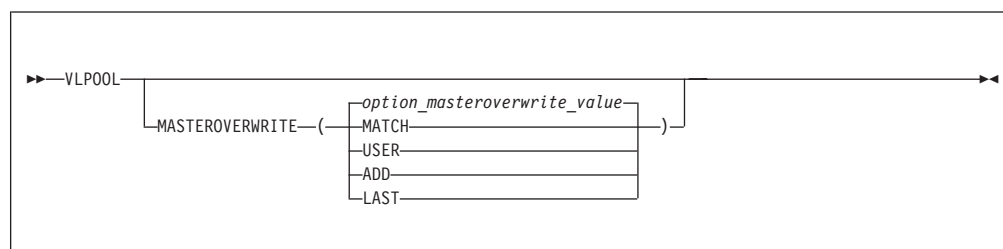

### ADD

Specify this value so new data can be created and no existing data can be destroyed. No existing file on a volume can be recreated, but the last file can have new data added to it. When adding data to the last file, DFSMSrmm checks that the data set name used must match the existing data set name. Select this option when you want the last file on the volume to be extended or a new file added to the volume.

**Note:** DFSMSrmm enforces the MASTEROVERWRITE(ADD) option on a WORM tape that is in master status. This is done to ensure that you see a message from DFSMSrmm rather than one of a number of symptoms as a result of the tape drive preventing overwrites.

### LAST

Specify this value to ensure that when an existing file on a master volume is being written to that only the last file on the volume can be used. The data set name used must match the existing data set name. Select this option when you want the last file on the volume to be used for output.

### MATCH

Specify this value to ensure that when an existing file on a master volume is

being used for output that exactly the same data set name must be used. Select this option when you want any existing file on the volume to be recreated regardless of whether it is the last file on the volume as long as the same data set name is used.

When you use an existing tape file for output all the files which are higher in sequence are destroyed.

#### **USER**

Specify this value to allow any existing file on a master volume to be used for output regardless of the data set names being used and its relative file position on the volume. Select this option when you want validation of master volumes to be just the same as for user status volumes.

When you use an existing tape file for output all the files which are higher in sequence are destroyed.

Default: The DFSMSrmm parmlib member EDGRMMxx OPTION command MASTEROVERWRITE operand value when you do not specify a VLPOOL MASTEROVERWRITE value.

---

## **SMSACS Input Variables for RMMVRS and RMMPOOL ACS Calls**

You use the ACS routines to process the special calls that DFSMSrmm makes to the SMS subsystem for ACS processing. DFSMSrmm provides the DATACLAS variable if it is available in addition to the ACS read-only variables when requesting that either a management class or storage group is returned.

#### **Related reading:**

See *z/OS DFSMSrmm Implementation and Customization Guide* for additional information about DFSMSrmm calls to the SMS ACS routines.

---

## **Using DFSMSrmm to manage WORM tapes**

DFSMSrmm validates WORM tapes at OPEN time and rejects any WORM tapes using this criteria.

- DFSMSrmm ensures that the mounted volume has the correct WWID. DFSMSrmm obtains the WWID for a WORM tape from the tape drive when the volume is mounted and used or when you define the WORM tape to DFSMSrmm using the RMM TSO subcommands.
- When DFSMSrmm has a Write Mount Count for a WORM media, DFSMSrmm ensures that the mounted volume write mount count matches the value recorded in the DFSMSrmm control database.
- DFSMSrmm enforces the MASTEROVERWRITE(ADD) option on a WORM tape that is in master status. This is done to ensure that you see a message from DFSMSrmm rather than one of a number of symptoms as a result of the tape drive preventing overwrites. When a WORM volume is in user status, DFSMSrmm does not enforce the same checks, but does prevent any updates to information records in the DFSMSrmm control data set for existing data sets that are written to the volume. In the latter case, any write or rewrite of data on the volume is subject to the checks built into IBM's WORM tape functionality, so it may or may not be allowed.

For a WORM tape that has been successfully validated, DFSMSrmm records the WWID and write mount count from the tape drive if there are no values defined to DFSMSrmm.

## Defining WORM tapes to DFSMSrmm

You can use the RMM ADDVOLUME subcommand to define volumes to DFSMSrmm. When you are defining WORM tapes to DFSMSrmm, allow DFSMSrmm to record the volume WWID when the volume is first used on the system rather than specifying the WWID yourself. This ensures that the WWID for the volume is recorded correctly.

## Segregating WORM tapes in separate scratch pools

When you use scratch pooling for non-system-managed tape or use an manual tape library, ensure that WORM tapes are in a separate scratch pool. If you mix WORM tape and non-WORM tape in a scratch pool, you cannot control the type of tape that will be mounted for a non-specific volume request.

## Changing the status of WORM tapes

DFSMSrmm prevents WORM tapes from returning to scratch to prevent their misuse. If you inadvertently define a WORM tape as MASTER volume or a USER volume, you cannot scratch the volume once it has been used for input or output. You can change the status of a WORM tape to scratch status using one of these techniques.

1. Use the RMM DELETEVOLUME *volser* FORCE command to delete the volume.
2. Use the RMM ADDVOLUME *volser* STATUS(SCRATCH) command to add the volume to DFSMSrmm with the scratch status.
3. Use the RMM CHANGEVOLUME *volser* RELEASE(REPLACE) CONFIRMRELEASE(REPLACE) command to set the release action for the volume to REPLACE and to clear information about the volume from the DFSMSrmm control data set.
4. Optionally, use the RMM CHANGEVOLUME *volser* CONFIRMRELEASE(INIT) command to confirm that the volume is already labeled.
5. Run DFSMSrmm expiration processing to set the volume to scratch status.

## Identifying WORM tapes ready for destruction

Because WORM tapes cannot be reused, you cannot return the volumes to the scratch pool when the data has expired. Normally you would expect the volumes to be destroyed once all the data has expired. DFSMSrmm provides support for automating the management of this process using the existing volume release actions. By default DFSMSrmm sets the return to owner release action, but you can alternatively use the replace release action by changing the release action at any time during the volumes life.

You can set the release actions for the volumes to trigger one of these actions.

- List all the WORM tapes that are pending return to their owner. Pick the volumes from the list and destroy them. After the volumes are destroyed, use the RMM CHANGEVOLUME \* CRLSE(RETURN) or RMM CHANGEVOLUME *volser* CRLSE(RETURN) command to confirm the release action which deletes the volume information from the DFSMSrmm control data set.
- List all the WORM tapes that are pending replacement. Pick the volumes from the list and destroy them. Create new WORM tapes that use the same set of volume serial numbers. After the volumes are destroyed, use the RMM CHANGEVOLUME \* CRLSE(REPLACE) or RMM CHANGEVOLUME *volser* CRLSE(REPLACE) command to confirm the release action which updates the volume information in the DFSMSrmm control data set to reflect the volume that has been replaced with a new volume.





---

## Chapter 59. EREP modifications for 3592 Model J

Environmental Recording, Editing, and Printing (EREP) program is a diagnostic application program that runs under MVS, VM, and VSE. It generates and prints reports from error recording data set (ERDS) records. With these reports, IBM service representatives can determine the existence, nature, and location of a problem.

This topic describes changes to the tape subsystem exception, event history, system error summary, and emulated device summary reports of the EREP program to support 3592 Model J tape drives.

---

### Tape subsystem exception report

As shown in Figure 39, EREP reports a temporary ORB record in its tape subsystem exception report in support of 3592 Model J tape drives.

```
TAPE SUBSYSTEM EXCEPTION REPORT                                REPORT DATE 050 04
                                                             PERIOD FROM 076 02
                                                             TO    077 02

*** SEQUENCE BY PROBABLE FAILING UNIT ***

PROBABLE  DEVICE          FAILURE          CPU  DEVNO  -----TOTALS-----
FAILING   TYPE/          AFFECT              /CUA  SIMS  MIMS  OBR  OBR
UNIT      VOLID                                     /CUA  SIMS  MIMS  PERM TEMP
*****
LIBRARY                                     TOTAL  0    0    0    1
          3570-CXX  LIBRARY INFORMATIONAL DATA  00  07C2  0    0    0    1
DEVICE                                     TOTAL  0    0    2    1
          3590-H1X  LIBRARY DRIVE NOT UNLOADED  02  0C24  0    0    1    0
          3592-J1X  WORM OVERWRITE REJECTED          03  0C27  0    0    0    1
```

Figure 39. Partial event history report

---

### Event history report

As shown in Figure 40 on page 402, EREP reports 3590 as the native device type in its event history report in support of 3592 Model J tape drives.

EVENT HISTORY (S/370 & S/370XA)						
TIME	JOBNAME	RECTYP	CP	CUA	SSYS	DEVT
DATE			*	DNO		CRW
02 15 34 50	N/A	MDR	01	04B2	3590	04
02 22 35 74	N/A	MDR	00	04B0	3590	04
10 02 06 17	DRVNDSA	OBRTMP	03	0591	3590	
10 02 10 78	DRVNDSA	OBRPRM	03	0591	3590	
12 54 45 51	VARY	OBRPRM	06	0563	3590	06
23 08 25 93	DISB/RGP	OBRTMP	00	04BA	3590	04
23 08 25 93	DISB/RGP	OBRPRM	00	04BA	3590	
23 08 25 93	DISB/RGP	OBRTMP	00	04BE	3590	16

Figure 40. Partial event history report

### System error summary report

Figure 41 illustrates that the EREP system error summary report is changed to support 3592 Model J tape drives. The system error summary for 3590 includes the system error summary report series for 3490. These reports are only shown for 3590 devices that emulate 3490 devices.

SYSTEM ERROR SUMMARY (PART 2)									
REPORT DATE 054 99									
PERIOD FROM 044 98									
TO 022 02									
TIME	JOBNAME	CPU	PHYSICAL ID	PHYSICAL TYPE	PHYSICAL ADDRESS	ERROR PATH	ERROR VOLUME	ERROR DESC	PROBABLE FAILING
DATE 358/99									
10:02:10:78	DRVNDSA	02	N/A	3590	0591	0591		N/A	HARDWARE
23:08:25:93	DISB/RGP	00	N/A	3590	04BA	16-04BA		N/A	VOLUME/C

Figure 41. Partial system error summary report

### Emulated device summary report

Figure 42 on page 403 provides an example of an EREP emulated device summary report. The report in this example shows the emulated device type for 3592 Model J tape drives. The report includes an example of a 3592-J1X emulating a 3490-CXX and an example of a 3592-J1X emulating a 3590-B1X.

3590 DEVICE SUMMARY

REPORT DATE 104 99  
PERIOD FROM 044 98  
TO 019 99

DEVICE ADDRESS	REAL / EMULATED DEVICE TYPE
014C	3590-E1X / 3490-CXX
014D	3590-B1X / 3490-CXX
014E	3590-E1X / 3490-CXX
0231	3590-H1X / 3490-CXX
0232	3590-H1X / 3490-CXX
0233	3590-H1X / 3490-CXX
0234	3592-J1X / 3490-CXX
04B8	3590-B1X / 3490-CXX
04B9	3590-B1X / 3490-CXX
04BA	3590-B1X / 3490-CXX
04BB	3590-B1X / 3490-CXX
04BC	3590-B1X / 3490-CXX
0591	3590-E1X / 3490-CXX
0592	3590-E1X / 3490-CXX
0880	3590-XXX / NATIVE
0881	3590-XXX / NATIVE
0882	3590-XXX / NATIVE
0883	3590-XXX / NATIVE
0884	3590-XXX / NATIVE
088A	3590-XXX / NATIVE
08AA	3590-E1X / 3590-B1X
08AB	3590-E1X / 3590-B1X
08AC	3592-J1X / 3590-B1X

Figure 42. Partial emulated device summary report



---

## Chapter 60. JES3 modifications for 3592 Model J

JES3, a z/OS MVS subsystem, manages resources and work flow before and after jobs are processed. You can enable JES3 to allocate 3592 Model J tape drives and tape volumes in an SMS-managed IBM tape library environment (automated or manual) for 3590 Model B emulation only. To do so, you need to specify at least one of these library device group (LDG) names in your JES3plex. An LDG is a predefined set of tape subsystems within a JES3plex.

- **LDG***dddd*. *dddd*=359J indicates that a 3592 Model J tape drive emulates a 3590 Model B in any library within the JES3plex.
- **LDJ***sssss*. The serial number *sssss* indicates the library within which a 3592 Model J tape drive that emulates a 3590 Model B resides.

**Related reading:**

See *z/OS JES3 Initialization and Tuning Reference* for additional information on LDGs, JES3, and JES3plex.



---

## Chapter 61. OAM modifications for 3592 Model J

The Object Access Method (OAM) is a component of DFSMSdftp. OAM uses the concepts of system-managed storage, introduced by SMS, to manage, maintain, and verify tape volumes and tape libraries within a tape storage environment. You can also use OAM's object support to manage objects on DASD, tape, and optical volumes.

### Related reading:

- See *z/OS DFSMS OAM Planning, Installation, and Storage Administration Guide for Tape Libraries* for additional information about using OAM to manage tape volumes and tape libraries.
- See *z/OS DFSMS OAM Planning, Installation, and Storage Administration Guide for Object Support* for additional information about using OAM to manage the data on tape volumes.
- See *z/OS MVS System Messages, Vol 4 (CBD-DMO)* for explanations and appropriate actions for CBRxxxxx messages.

---

## OAM library support

OAM uses the concepts of system-managed storage, introduced by SMS, to manage, maintain, and verify tape volumes and tape libraries within a tape storage environment. This topic describes the OAM library support functions that have been changed for use with the 3592 Model J tape drives.

### LCS external services changes

LCS External Services supports the media types, MEDIA5, MEDIA6, MEDIA7, and MEDIA8, and the recording technology, EFMT1, for these functions:

- Change use attribute
- Query volume residence
- Test volume eligibility
- Eject a volume
- Manual cartridge entry

### OAM installation exits changes

These installation exits support EFMT1 recording technology and MEDIA5, MEDIA6, MEDIA7, and MEDIA8 media types:

- Change use attribute (CBRUXCUA) installation exit: Tape recording technology fields and media type fields have been updated with EFMT1 and MEDIA5, MEDIA6, MEDIA7, and MEDIA8.
- The UXCWORM indicator is set to on if the volume is a WORM media type. The tape management system is alerted that the CUA function is being performed for a WORM volume when invoking the CBRUXCUA installation exit.
- Cartridge entry (CBRUXENT) installation exit: Tape recording technology fields and media type fields have been updated with EFMT1 and MEDIA5, MEDIA6, MEDIA7, and MEDIA8.
- Cartridge eject (CBRUXEJC) installation exit: Tape recording technology fields and media type fields have been updated with EFMT1 and MEDIA5, MEDIA6, MEDIA7, and MEDIA8.

- Volume not in library (CBRUXVNL) installation exit: Tape recording technology fields and media type fields have been updated with EFMT1 and MEDIA5, MEDIA6, MEDIA7, and MEDIA8.

## Operator command support changes

These operator tasks have been changed in support of the 3592 Model J tape drives.

- To obtain information about recording technology and media type for volume AN4441, issue the command:

```
DISPLAY SMS,VOLUME(AN4441)
```

In this example, OAM displays EFMT1 and MEDIA5 in the output display for CBR1180I (OAM tape volume status) for the recording technology and media type.

```
CBR1180I OAM tape volume status:
VOLUME MEDIA STORAGE LIBRARY USE W C SOFTWARE LIBRARY
      TYPE GROUP NAME ATR P P ERR STAT CATEGORY
AN4441 MEDIA5 SGATLOBJ ATL10001 P N N NOERROR PRIVATE
-----
RECORDING TECH: EFMT1 COMPACTTION: YES
SPECIAL ATTRIBUTE: NONE ENTER/EJECT DATE: 2003-05-30
CREATION DATE: 2003-05-30 EXPIRATION DATE:
LAST MOUNTED DATE: 2003-07-03 LAST WRITTEN DATE: 2003-07-03
SHELF LOCATION:
OWNER:
-----
```

In this example, OAM displays EFMT1 and MEDIA6 in the output display for CBR1180I (OAM tape volume status) for the recording technology and media type. A new WORM media indicator is also displayed.

```
CBR1240I Object tape vol status:
VOLUME STORAGE UNITNAME RD WR CM IN MED FREE-SPACE % LOST REQ
      GROUP USE TYPE FULL FLAG CT
JWC053 GROUP52 3590-1 Y Y Y N 08 292968448 0 N 0
Volume is WORM tape.
XCF MEMBER NAME: OAMSYS1
CAPACITY: 292968448
ERDS PHYSICAL ID: 0010
CREATION DATE: 2004-04-01 EXPIRATION DATE: 0001-01-01
LAST MOUNTED DATE: 2004-04-01 LAST WRITTEN DATE: 2004-04-01
CBR1180I OAM tape volume status:
VOLUME MEDIA STORAGE LIBRARY USE W C SOFTWARE LIBRARY
      TYPE GROUP NAME ATR P P ERR STAT CATEGORY
JWC053 MEDIA6 SGATLOBJ ATL10001 P N N NOERROR PRIVATE
-----
RECORDING TECH: EFMT1 COMPACTTION: UNKNOWN
SPECIAL ATTRIBUTE: NONE ENTER/EJECT DATE: 2004-03-30
CREATION DATE: 2004-03-30 EXPIRATION DATE:
LAST MOUNTED DATE: 2004-04-01 LAST WRITTEN DATE: 2004-04-01
SHELF LOCATION:
OWNER:
-----
```

Volume is WORM tape.

- To display tape drive status, issue the command:

```
LIBRARY DISPDRV,BC0
```

In this example, OAM displays 3592-J, as the device type for a 3592 Model J device, and as appropriate, MEDIA5, MEDIA6, MEDIA7, or MEDIA8 as the ICL CATEGORY, in the output display for CBR1220I (tape drive status).



```

CBR1220I Tape drive status:
DRIVE DEVICE LIBRARY ON OFFREASN LM ICL ICL MOUNT
NUM TYPE NAME LI OP PT AV CATEGRY LOAD VOLUME
0BC0 3592-J ATL10001 Y N N N A NONE N

```

- To enter the MEDIA5, MEDIA6, MEDIA7, or MEDIA8 media type into a manual tape library, issue the command:

```
LIBRARY ENTER, volser, library_name, media_type
```

where media\_type is MEDIA5, MEDIA6, MEDIA7, or MEDIA8

- To set the media type of scratch volumes to be loaded into a 3592 Model J device that supports a cartridge loader, issue the command:

```
LIBRARY SETCL, device_number, media_type
```

where media\_type is MEDIA5, MEDIA6, MEDIA7, or MEDIA8

- To display the MEDIA5, MEDIA6, MEDIA7, and MEDIA8 scratch count, scratch threshold, and scratch category in the output display for CBR1110I, issue the command:

```
DISPLAY SMS,LIBRARY(ATL10001),DETAIL
```

```

CBR1110I OAM library status:
TAPE LIB DEVICE TOT ONL AVL TOTAL EMPTY SCRTCH ON OP
LIBRARY TYP TYPE DRV DRV DRV SLOTS SLOTS VOLS
ATL10001 AL 3494-L10 6 1 1 1299 304 2 Y Y

```

```

-----
MEDIA SCRATCH SCRATCH SCRATCH
TYPE COUNT THRESHOLD CATEGORY
MEDIA1 0 1 0281
MEDIA2 0 1 0282
MEDIA3 1 1 0283
MEDIA4 1 1 0284
MEDIA5 0 2 0285
MEDIA6 0 2 0286
MEDIA7 0 2 0287
MEDIA8 0 2 0288
-----

```

```

OPERATIONAL STATE: AUTOMATED
ERROR CATEGORY SCRATCH COUNT: 0
HIGH CAPACITY INPUT STATION CAPACITY: 105
HIGH CAPACITY OUTPUT STATION CAPACITY: 105
-----

```

```

Convenience I/O station installed.
Convenience I/O station in Output mode.
Convenience I/O station Empty.
Bulk input/output configured.

```

## OAM macro changes

Table 65 describes changes to OAM mapping macros and installation exit parameter lists in support of 3592 Model J tape drives.

Table 65. OAM mapping macro changes

The macro	that maps	has these changes.
CBRLCSPL	the LCS External Services parameter list	LCSIVLMM EQU 24 INVALID VOLUME LIST, MIXED MEDIA, REWRITABLE AND WORM VOLUMES

Table 65. OAM mapping macro changes (continued)

The macro	that maps	has these changes.
CBRTDSI	the tape device selection information (TDSI)	<p>TDSEFMT1 EQU 6 READ/WRITE on ENTERPRISE FORMAT 1 (EFMT1) DEVICE</p> <p>TDSMED5 EQU 5 MEDIA5 - ENTERPRISE TAPE CARTRIDGE</p> <p>TDSMED6 EQU 6 MEDIA6 - ENTERPRISE WORM TAPE CARTRIDGE</p> <p>TDSMED7 EQU 7 MEDIA7 - ENTERPRISE ECONOMY TAPE CARTRIDGE</p> <p>TDSMED8 EQU 8 MEDIA8 - ENTERPRISE ECONOMY WORM TAPE CARTRIDGE</p>
CBRTVI	the tape volume information	<p>TVIEFMT1 EQU 6 READ/WRITE on ENTERPRISE FORMAT 1 (EFMT1) DEVICE</p> <p>TVIMED5 EQU 5 MEDIA5 - ENTERPRISE TAPE CARTRIDGE</p> <p>TVIMED6 EQU 6 MEDIA6 - ENTERPRISE WORM TAPE CARTRIDGE</p> <p>TVIMED7 EQU 7 MEDIA7 - ENTERPRISE ECONOMY TAPE CARTRIDGE</p> <p>TVIMED8 EQU 8 MEDIA8 - ENTERPRISE ECONOMY WORM TAPE CARTRIDGE</p> <p>TVISCRM5 EQU C'S5' Volume is MEDIA5 SCRATCH</p> <p>TVISCRM6 EQU C'S6' Volume is MEDIA6 SCRATCH</p> <p>TVISCRM7 EQU C'S7' Volume is MEDIA7 SCRATCH</p> <p>TVISCRM8 EQU C'S8' Volume is MEDIA8 SCRATCH</p> <p>TVIMEDTY has a new value for MEDIA5 which is X'05'</p> <p>TVIMEDTY has a new value for MEDIA6 which is X'06'</p> <p>TVIMEDTY has a new value for MEDIA7 which is X'07'</p> <p>TVIMEDTY has a new value for MEDIA8 which is X'08'</p>
CBRUXCPL	the change use attribute installation exit parameter list	<p>UXCEFMT1 EQU 6 READ/WRITE on ENTERPRISE FORMAT 1 (EFMT1) DEVICE</p> <p>UXCMED5 EQU 5 MEDIA5 - ENTERPRISE TAPE CARTRIDGE</p> <p>UXCMED6 EQU 6 MEDIA6 - ENTERPRISE WORM TAPE CARTRIDGE</p> <p>UXCMED7 EQU 7 MEDIA7 - ENTERPRISE ECONOMY TAPE CARTRIDGE</p> <p>UXCMED8 EQU 8 MEDIA8 - ENTERPRISE ECONOMY WORM TAPE CARTRIDGE</p>
CBRUXEPL	the cartridge entry installation exit parameter list	<p>UXEEFMT1 EQU 6 READ/WRITE on ENTERPRISE FORMAT 1 (EFMT1) DEVICE</p> <p>UXEMED5 EQU 5 MEDIA5 - ENTERPRISE TAPE CARTRIDGE</p> <p>UXEMED6 EQU 6 MEDIA6 - ENTERPRISE WORM TAPE CARTRIDGE</p> <p>UXEMED7 EQU 7 MEDIA7 - ENTERPRISE ECONOMY TAPE CARTRIDGE</p> <p>UXEMED8 EQU 8 MEDIA8 - ENTERPRISE ECONOMY WORM TAPE CARTRIDGE</p>

Table 65. OAM mapping macro changes (continued)

The macro	that maps	has these changes.
CBRUXJPL	the cartridge eject installation exit parameter list	UXJEFMT1 EQU 6 READ/WRITE on ENTERPRISE FORMAT 1 (EFMT1) DEVICE UXJMED5 EQU 5 MEDIA5 - ENTERPRISE TAPE CARTRIDGE UXJMED6 EQU 6 MEDIA6 - ENTERPRISE WORM TAPE CARTRIDGE UXJMED7 EQU 7 MEDIA7 - ENTERPRISE ECONOMY TAPE CARTRIDGE UXJMED8 EQU 8 MEDIA8 - ENTERPRISE ECONOMY WORM TAPE CARTRIDGE
CBRUXNPL	the volume not in library installation exit parameter list	UXNEFMT1 EQU 6 READ/WRITE on ENTERPRISE FORMAT 1 (EFMT1) DEVICE UXNMED5 EQU 5 MEDIA5 - ENTERPRISE TAPE CARTRIDGE UXNMED6 EQU 6 MEDIA6 - ENTERPRISE WORM TAPE CARTRIDGE UXNMED7 EQU 7 MEDIA7 - ENTERPRISE ECONOMY TAPE CARTRIDGE UXNMED8 EQU 8 MEDIA8 - ENTERPRISE ECONOMY WORM TAPE CARTRIDGE

## Scratch mount considerations

To request WORM tape cartridge media in a system-managed tape library environment, use data class with the media interchange specification indicating a WORM media type (MEDIA6 or MEDIA8). If a media type is not specified through data class and a 3592 device is allocated, MEDIA5 will be mounted with MEDIA7 as the alternate.

## 3592 drive level and allocation considerations

In a system-managed tape library environment, all the 3592 drives in a library need to be upgraded with the microcode support if MEDIA6, MEDIA7, or MEDIA8 media types are used. A mount failure occurs when a drive without the microcode upgrade is allocated for a mount request requiring one of the new media types.

---

## OAM object tape support

The Object Access Method (OAM) is also an access method supporting a class of data referred to as objects. An object is a named stream of bytes. The content, format, and structure of that byte stream are unknown to OAM. There are no restrictions on the data in an object. For example, an object can be a compressed scanned image or coded data. Objects are different from data sets handled by existing access methods.

In an IBM tape library environment, the SETOAM DATACLASS parameter can be specified using a data class that contains the media type or recording technology; these specifications are associated with an Object or Object Backup storage group in the CBROAMxx member of PARMLIB.

In a stand-alone environment, the SETOAM TAPEUNITNAME parameter can be specified using an esoteric that contains 3592 Model J devices. These specifications are associated with an Object or Object Backup storage group in the CBROAMxx member of PARMLIB.

In addition, the SETOAM DATACLASS parameter can also be used inside and outside an IBM tape library environment to take advantage of performance scaling. Performance scaling is only available with MEDIA5 (300GB) tape cartridge media. A DATACLASS with the performance scaling data class attribute selected can be specified for OBJECT storage groups to improve the random retrieval rate of primary objects; whereas, objects written to OBJECT BACKUP storage groups can specify a DATACLASS that does not specify performance scaling and can continue to utilize the full capacity of the MEDIA5 volume.

In addition to the performance scaling option available with the 300GB MEDIA5 cartridge, the 60GB MEDIA7 economy cartridge can also be used to improve the random retrieval rate of primary objects.

#### **Recommendations:**

- To use the volumes effectively, we recommend that you run in 3590-1 emulation mode, otherwise with 3490E emulation, OAM will run out of 22-bit tape blockids before being able to fill the tape.

**Note:** The 3592 Model J does not support 3490E emulation mode with MEDIA6, MEDIA7, or MEDIA8 tape cartridge media.

- To guarantee that objects written on any drive in the esoteric group can be read on any drive in the same esoteric group, specify esoteric unit names with compatible recording technologies.
- In order to prevent allocating an inappropriate drive for a request, it is important to segregate, in an esoteric or a generic, the 3592 Model J devices with the upgraded microcode support for MEDIA6, MEDIA7, and MEDIA8 from any other 3592 devices without the upgrade. Another alternative is to consider upgrading all 3592 drives.
- Storage groups using 3592 Model J drives should be comprised of either WORM tape volumes or rewritable tape volumes. In addition, you should consider the separation of standard length and economy length media types.
- In the system-managed tape library environment (automated or manual), the SETOAM DATACLASS parameter at the storage group, or global level, can be used to request a specific media type through the data class media interchange specification. Outside of the system-managed type library environment, the tape management system pooling support can be used to direct the storage group request to a particular set of media with a new option to now append the storage group name to the OAM object tape data set names.

Table 66 on page 413 shows the entry for the optical configuration database (OCDB) MEDIATYP field. The media type is defined in the MEDIATYP field. These media types are defined:

- MEDIATYP field is 07, meaning Enterprise Tape Cartridge. When utilizing the tape to its full capacity, the CAPACITY value for the media is 292 968 448 kilobytes and if utilizing the media to its performance scaled capacity, the CAPACITY value for the media is 60 653 568 kilobytes.
- MEDIATYP field is 08, meaning Enterprise WORM Tape Cartridge. When utilizing the tape to its full capacity, the CAPACITY value for the media is 292 968 448 kilobytes with the description of "Represents the approximate number of kilobytes of data for an IBM 3592 Enterprise WORM Tape Cartridge. This value will be returned from the drive (3592 Model J) and is used here as an approximation that will be close to actual value."

- MEDIATYP field is 09, meaning Enterprise Economy Tape Cartridge. When utilizing the tape to its full capacity, the CAPACITY value for the media is 60 653 568 kilobytes with the description of "Represents the approximate number of kilobytes of data for an IBM 3592 Enterprise Economy Tape Cartridge. This value will be returned from the drive (3592 Model J) and is used here as an approximation that will be close to actual value."
- MEDIATYP field is 10, meaning Enterprise Economy WORM Tape Cartridge. When utilizing the tape to its full capacity, the CAPACITY value for the media is 60 653 568 kilobytes with the description of "Represents the approximate number of kilobytes of data for an IBM 3592 Enterprise Economy WORM Tape Cartridge. This value will be returned from the drive (3592 Model J) and is used here as an approximation that will be close to actual value."

Table 66. Library table column descriptions

Column description	Name	DB2 type	DB2 attribute	Report label
Capacity of tape	CAPACITY	INTEGER	Not Null	CAPACITY
Media Type	MEDIATYP	CHAR(2)	Not Null	MEDIATYPE

---

## Object tape data set low-level qualifier enhancement

With the 3592 Model J support for new media types (MEDIA6, MEDIA7, and MEDIA8), OAM includes an enhancement to optionally append a low-level qualifier to the OAM object tape data set names. To assist the tape management system in mounting an appropriate media type in the stand-alone environment (non system-managed tape environment), the DSNWITHSGNAME global keyword on the SETOAM statement in the CBROAMxx PARMLIB member appends the object storage group name to the OAM data set names (OAM.PRIMARY.DATA, OAM.BACKUP.DATA, OAM.BACKUP2.DATA). For example, if OAM receives a store request for an object for storage group GROUP55, GROUP55 is appended as the low-level qualifier to the OAM.PRIMARY.DATA data set name, resulting in OAM.PRIMARY.DATA.GROUP55.

The tape management system can parse the data set low-level qualifier (storage group) to determine from which pool a scratch volume should be selected for a mount request in the stand-alone environment. By associating object storage group names with tape management scratch pools, specific media type volumes can be assigned to specific pool names and segregated, preventing a WORM volume request from being used for a rewritable volume request and vice versa.

Though discussion of the new DSNWITHSGNAME global keyword has centered around the stand-alone (non-system managed tape environment) where scratch allocations are typically satisfied with the assignment of a tape management system scratch pool versus the assignment of an appropriate data class, this new keyword can also be specified in the system-managed tape library environment to better identify what object storage group data is written to the tape.

Once the DSNWITHSGNAME is specified, all new OAM object data set names for all storage groups will have the storage group name appended. Regardless if DSNWITHSGNAME is specified or not, data sets written in the original data set name format or the new data set name format can be retrieved.

The MODIFY OAM, DISPLAY, and SETOAM command displays indicate if the GLOBAL DSNWITHSGNAME keyword is specified on the SETOAM statement in the CBROAMxx PARMLIB member.

Data set format column, DSNFMT, is added to the TAPEVOL table of the Optical Configuration Database. If a tape volume has a DSNFMT value of blank, the data set written on the volume is the original data set format with no storage group low-level qualifier or has no current OAM data set written on the tape. If a tape volume has a DSNFMT value of 'G' for group, the data set written on the volume has the storage group appended.

Sample JCL, CBRSMPPDS, adds the DSNFMT column to the TAPEVOL table in the Optical Configuration Database. Also, CBRSAMPL is modified to include the TAPEVOL DSNFMT column.

---

## Object tape volume management support

Starting with z/OS DFSMS V1R5, OAM supports expiring an object tape volume whose data on the volume is all expired. The tape volume can be deleted or recycled if it has no valid data remaining because of expired data or all valid data has been moved to another volume due to recovery, the move volume utility, or the OSMC shelf manager processing.

The 3592 support for the new media types (MEDIA6, MEDIA7, and MEDIA8) includes special handling of WORM (MEDIA6 and MEDIA8) tape volumes that have expired. Because WORM tape volumes cannot be written from load point, they cannot be recycled.

With WORM tape, once the volume has been filled and data has been expired or DELETE has been requested on the MOVEVOL or RECOVERY command, the WORM tape volume is processed like the OAM RECYCLE MVSSCRATCH option. All knowledge of the volume is removed from the OAM DB2 tape volume database. Message, CBR2173I, is issued to signal the tape management system that a WORM volume has been expired or deleted and requires special handling based on the installation's procedures. If the WORM storage group has OAMSCRATCH or GROUP option specified for the TAPERECYCLEMODE keyword in the SETOAM statement in the CBROAMxx parmlib member, the WORM tape is still handled like the MVSSCRATCH option had been specified since WORM tape cannot be rewritten from load point. Message CBR2165I continues to be issued for a rewritable tape volume that has been expired or deleted.

Rewritable tape volumes being recycled (OAMSCRATCH or GROUP) have their data set format field reset to blank, indicating no current OAM data set written on the volume.

---

## MOVEVOL command

Because WORM tape volumes cannot be rewritten from load point and cannot be recycled for reuse, the only MOVEVOL commands allowed are with the DELETE option, or MOVEVOL with no option specified. The MOVEVOL command with the RECYCLE option is rejected for a WORM tape volume.

---

## Part 6. Appendixes





---

## Appendix. Accessibility

Publications for this product are offered in Adobe Portable Document Format (PDF) and XHTML through the z/OS Information Center, at <http://publib.boulder.ibm.com/infocenter/zos/v2r1/index.jsp>. If you experience difficulty with the accessibility of any z/OS information, send an email to [mhvrcfs@us.ibm.com](mailto:mhvrcfs@us.ibm.com) or write to:

IBM Corporation  
Attention: MHVRCFS Reader Comments  
Department H6MA, Building 707  
2455 South Road  
Poughkeepsie, NY 12601-5400  
USA

Accessibility features help a user who has a physical disability, such as restricted mobility or limited vision, to use software products successfully. The major accessibility features in z/OS enable users to:

- Use assistive technologies such as screen readers and screen magnifier software
- Operate specific or equivalent features using only the keyboard
- Customize display attributes such as color, contrast, and font size.

---

### Using assistive technologies

Assistive technology products, such as screen readers, function with the user interfaces found in z/OS. Consult the assistive technology documentation for specific information when using such products to access z/OS interfaces.

---

### Keyboard navigation of the user interface

Users can access z/OS user interfaces using TSO/E or ISPF. Refer to *z/OS TSO/E Primer*, *z/OS TSO/E User's Guide*, and *z/OS ISPF User's Guide Vol I* for information about accessing TSO/E and ISPF interfaces. These guides describe how to use TSO/E and ISPF, including the use of keyboard shortcuts or function keys (PF keys). Each guide includes the default settings for the PF keys and explains how to modify their functions.

---

### Dotted decimal syntax diagrams

Syntax diagrams are provided in dotted decimal format for users accessing the Information Center using a screen reader. In dotted decimal format, each syntax element is written on a separate line. If two or more syntax elements are always present together (or always absent together), they can appear on the same line, because they can be considered as a single compound syntax element.

Each line starts with a dotted decimal number; for example, 3 or 3.1 or 3.1.1. To hear these numbers correctly, make sure that your screen reader is set to read out punctuation. All the syntax elements that have the same dotted decimal number (for example, all the syntax elements that have the number 3.1) are mutually exclusive alternatives. If you hear the lines 3.1 USERID and 3.1 SYSTEMID, you know that your syntax can include either USERID or SYSTEMID, but not both.

The dotted decimal numbering level denotes the level of nesting. For example, if a syntax element with dotted decimal number 3 is followed by a series of syntax elements with dotted decimal number 3.1, all the syntax elements numbered 3.1 are subordinate to the syntax element numbered 3.

Certain words and symbols are used next to the dotted decimal numbers to add information about the syntax elements. Occasionally, these words and symbols might occur at the beginning of the element itself. For ease of identification, if the word or symbol is a part of the syntax element, it is preceded by the backslash (\) character. The \* symbol can be used next to a dotted decimal number to indicate that the syntax element repeats. For example, syntax element \*FILE with dotted decimal number 3 is given the format 3 \\* FILE. Format 3\* FILE indicates that syntax element FILE repeats. Format 3\* \\* FILE indicates that syntax element \* FILE repeats.

Characters such as commas, which are used to separate a string of syntax elements, are shown in the syntax just before the items they separate. These characters can appear on the same line as each item, or on a separate line with the same dotted decimal number as the relevant items. The line can also show another symbol giving information about the syntax elements. For example, the lines 5.1\*, 5.1 LASTRUN, and 5.1 DELETE mean that if you use more than one of the LASTRUN and DELETE syntax elements, the elements must be separated by a comma. If no separator is given, assume that you use a blank to separate each syntax element.

If a syntax element is preceded by the % symbol, this indicates a reference that is defined elsewhere. The string following the % symbol is the name of a syntax fragment rather than a literal. For example, the line 2.1 %OP1 means that you should refer to separate syntax fragment OP1.

The following words and symbols are used next to the dotted decimal numbers:

- ? means an optional syntax element. A dotted decimal number followed by the ? symbol indicates that all the syntax elements with a corresponding dotted decimal number, and any subordinate syntax elements, are optional. If there is only one syntax element with a dotted decimal number, the ? symbol is displayed on the same line as the syntax element, (for example 5? NOTIFY). If there is more than one syntax element with a dotted decimal number, the ? symbol is displayed on a line by itself, followed by the syntax elements that are optional. For example, if you hear the lines 5 ?, 5 NOTIFY, and 5 UPDATE, you know that syntax elements NOTIFY and UPDATE are optional; that is, you can choose one or none of them. The ? symbol is equivalent to a bypass line in a railroad diagram.
- ! means a default syntax element. A dotted decimal number followed by the ! symbol and a syntax element indicates that the syntax element is the default option for all syntax elements that share the same dotted decimal number. Only one of the syntax elements that share the same dotted decimal number can specify a ! symbol. For example, if you hear the lines 2? FILE, 2.1! (KEEP), and 2.1 (DELETE), you know that (KEEP) is the default option for the FILE keyword. In this example, if you include the FILE keyword but do not specify an option, default option KEEP will be applied. A default option also applies to the next higher dotted decimal number. In this example, if the FILE keyword is omitted, default FILE(KEEP) is used. However, if you hear the lines 2? FILE, 2.1, 2.1.1! (KEEP), and 2.1.1 (DELETE), the default option KEEP only applies to the next

higher dotted decimal number, 2.1 (which does not have an associated keyword), and does not apply to 2? FILE. Nothing is used if the keyword FILE is omitted.

- \* means a syntax element that can be repeated 0 or more times. A dotted decimal number followed by the \* symbol indicates that this syntax element can be used zero or more times; that is, it is optional and can be repeated. For example, if you hear the line 5.1\* data area, you know that you can include one data area, more than one data area, or no data area. If you hear the lines 3\*, 3 HOST, and 3 STATE, you know that you can include HOST, STATE, both together, or nothing.

**Note:**

1. If a dotted decimal number has an asterisk (\*) next to it and there is only one item with that dotted decimal number, you can repeat that same item more than once.
  2. If a dotted decimal number has an asterisk next to it and several items have that dotted decimal number, you can use more than one item from the list, but you cannot use the items more than once each. In the previous example, you could write HOST STATE, but you could not write HOST HOST.
  3. The \* symbol is equivalent to a loop-back line in a railroad syntax diagram.
- + means a syntax element that must be included one or more times. A dotted decimal number followed by the + symbol indicates that this syntax element must be included one or more times; that is, it must be included at least once and can be repeated. For example, if you hear the line 6.1+ data area, you must include at least one data area. If you hear the lines 2+, 2 HOST, and 2 STATE, you know that you must include HOST, STATE, or both. Similar to the \* symbol, the + symbol can only repeat a particular item if it is the only item with that dotted decimal number. The + symbol, like the \* symbol, is equivalent to a loop-back line in a railroad syntax diagram.



---

## Notices

This information was developed for products and services offered in the U.S.A. or elsewhere.

IBM may not offer the products, services, or features discussed in this document in other countries. Consult your local IBM representative for information on the products and services currently available in your area. Any reference to an IBM product, program, or service is not intended to state or imply that only that IBM product, program, or service may be used. Any functionally equivalent product, program, or service that does not infringe any IBM intellectual property right may be used instead. However, it is the user's responsibility to evaluate and verify the operation of any non-IBM product, program, or service.

IBM may have patents or pending patent applications covering subject matter described in this document. The furnishing of this document does not give you any license to these patents. You can send license inquiries, in writing, to:

IBM Director of Licensing  
IBM Corporation  
North Castle Drive  
Armonk, NY 10504-1785  
U.S.A

For license inquiries regarding double-byte character set (DBCS) information, contact the IBM Intellectual Property Department in your country or send inquiries, in writing, to:

Intellectual Property Licensing  
Legal and Intellectual Property Law  
IBM Japan, Ltd.  
19-21, Nihonbashi-Hakozakicho, Chuo-ku  
Tokyo 103-8510, Japan

The following paragraph does not apply to the United Kingdom or any other country where such provisions are inconsistent with local law: INTERNATIONAL BUSINESS MACHINES CORPORATION PROVIDES THIS PUBLICATION "AS IS" WITHOUT WARRANTY OF ANY KIND, EITHER EXPRESS OR IMPLIED, INCLUDING, BUT NOT LIMITED TO, THE IMPLIED WARRANTIES OF NON-INFRINGEMENT, MERCHANTABILITY OR FITNESS FOR A PARTICULAR PURPOSE. Some states do not allow disclaimer of express or implied warranties in certain transactions, therefore, this statement may not apply to you.

This information could include technical inaccuracies or typographical errors. Changes are periodically made to the information herein; these changes will be incorporated in new editions of the publication. IBM may make improvements and/or changes in the product(s) and/or the program(s) described in this publication at any time without notice.

Any references in this information to non-IBM Web sites are provided for convenience only and do not in any manner serve as an endorsement of those Web sites. The materials at those Web sites are not part of the materials for this IBM product and use of those Web sites is at your own risk.

IBM may use or distribute any of the information you supply in any way it believes appropriate without incurring any obligation to you.

Licensees of this program who wish to have information about it for the purpose of enabling: (i) the exchange of information between independently created programs and other programs (including this one) and (ii) the mutual use of the information which has been exchanged, should contact:

Site Counsel  
IBM Corporation  
2455 South Road  
Poughkeepsie, NY 12601-5400  
USA

Such information may be available, subject to appropriate terms and conditions, including in some cases, payment of a fee.

The licensed program described in this information and all licensed material available for it are provided by IBM under terms of the IBM Customer Agreement, IBM International Program License Agreement, or any equivalent agreement between us.

Information concerning non-IBM products was obtained from the suppliers of those products, their published announcements or other publicly available sources. IBM has not tested those products and cannot confirm the accuracy of performance, compatibility or any other claims related to non-IBM products. Questions on the capabilities of non-IBM products should be addressed to the suppliers of those products.

All statements regarding IBM's future direction or intent are subject to change or withdrawal without notice, and represent goals and objectives only.

If you are viewing this information softcopy, the photographs and color illustrations may not appear.

#### COPYRIGHT LICENSE:

This information might contain sample application programs in source language, which illustrate programming techniques on various operating platforms. You may copy, modify, and distribute these sample programs in any form without payment to IBM, for the purposes of developing, using, marketing or distributing application programs conforming to the application programming interface for the operating platform for which the sample programs are written. These examples have not been thoroughly tested under all conditions. IBM, therefore, cannot guarantee or imply reliability, serviceability, or function of these programs. The sample programs are provided "AS IS", without warranty of any kind. IBM shall not be liable for any damages arising out of your use of the sample programs.

---

## Policy for unsupported hardware

Various z/OS elements, such as DFSMS, HCD, JES2, JES3, and MVS, contain code that supports specific hardware servers or devices. In some cases, this device-related element support remains in the product even after the hardware devices pass their announced End of Service date. z/OS may continue to service element code; however, it will not provide service related to unsupported hardware devices. Software problems related to these devices will not be accepted

for service, and current service activity will cease if a problem is determined to be associated with out-of-support devices. In such cases, fixes will not be issued.

---

## Minimum supported hardware

The minimum supported hardware for z/OS releases identified in z/OS announcements can subsequently change when service for particular servers or devices is withdrawn. Likewise, the levels of other software products supported on a particular release of z/OS are subject to the service support lifecycle of those products. Therefore, z/OS and its product publications (for example, panels, samples, messages, and product documentation) can include references to hardware and software that is no longer supported.

- For information about software support lifecycle, see: IBM Lifecycle Support for z/OS (<http://www.ibm.com/software/support/systemsz/lifecycle/>)
- For information about currently-supported IBM hardware, contact your IBM representative.

---

## Programming interface information

This document primarily documents information that is *not* intended to be used as a programming interface of z/OS DFSMS.

---

## Trademarks

DFSMSrmm  
IBM  
IBMLink  
RACF  
z/OS  
z/VM

Microsoft, Windows, Windows NT, and the Windows logo are trademarks of Microsoft Corporation in the United States, other countries, or both.

UNIX is a registered trademark of The Open Group in the United States and other countries.

Linux is a trademark of Linus Torvalds in the United States, other countries, or both.

Apache Tomcat and Tomcat are trademarks of the Apache Software Foundation in the United States, other countries, or both.

Other company, product, and service names may be trademarks or service marks of others.





---

## Glossary

The terms in this glossary are defined as they pertain to the software support for the IBM System Storage Tape System 3592. This glossary might include terms and definitions from the following references:

- *The American National Standard Dictionary for Information Systems*, ANSI X3.172-1990, copyright 1990 by the American National Standards Institute (ANSI). Copies may be purchased from the American National Standards Institute, 11 West 42nd Street, New York 10036.
- *The Information Technology Vocabulary*, developed by Subcommittee 1, Joint Technical Committee 1, of the International Electrotechnical Commission (ISO/IEC JTC2/SC1).
- *IBM Dictionary of Computing*, New York: McGraw-Hill, 1994.

**3480** An IBM 3480 Magnetic Tape Subsystem device that is capable of recording data only in the 3480 format.

**3480X** A 3480 XF device or an IBM 3490 Magnetic Tape Subsystem device that is capable of recording data in either the 3480 format or the 3480 XF (IDRC) format.

**3490** An IBM 3490 Magnetic Tape Subsystem device.

**3490E** See 3490.

**3590** An IBM TotalStorage Enterprise Tape Drive 3590 that operates as a 3590-B1x. See 3590-B1x, 3590-E1x and 3590-H1x.

**3590B1x**  
An IBM TotalStorage Enterprise Tape Drive 3590 Model B1x .

**3590E1x**  
An IBM TotalStorage Enterprise Tape Drive 3590 Model E1x .

**3590H1x**  
An IBM TotalStorage Enterprise Tape Drive 3590 Model H1x.

**3592J1A**  
IBM System Storage Tape System 3592 Model J.

**3592E05**  
IBM System Storage Tape System 3592 Model E05.

**3592E06**  
IBM System Storage Tape System 3592 Model E06.

**3592E07**  
IBM System Storage Tape System 3592 Model E07.

### access method services (AMS)

A multifunction service program that manages VSAM and non-VSAM data sets, as well as integrated catalog facility (ICF) catalogs.

**ACF** Automated cartridge facility.

**ACL** Automatic cartridge loader.

**ACS** Automatic class selection.

### allocation

Generically, the entire process of obtaining a volume and unit of external storage, and setting aside space on that storage for a data set.

**AMS** Access method services.

**AOM** Asynchronous operation manager.

**APAR** Authorized program analysis report.

**API** Application programming interface.

**ATL** Automated tape library.

**ATLDS**  
Automated tape library dataserver.

### automated tape library

A device consisting of robotic components, cartridge storage areas, tape subsystems, and controlling hardware and software, together with the set of tape volumes that reside in the library and can be mounted on the library tape drives.

### automatic cartridge loader

An optional feature of the 3480 magnetic tape subsystem that allows preloading of multiple tape cartridges. This feature is standard in the 3490 magnetic tape subsystem.

**automatic class selection (ACS)**

Routines that determine the data class, management class, storage class, and storage group for a JCL DD statement. The storage administrator is responsible for establishing ACS routines appropriate to an installation's storage requirements.

**backup**

The process of creating a copy of a data set or object to be used in case of accidental loss.

**cartridge system tape**

The base tape cartridge media used with 3480 or 3490 magnetic tape subsystems.

**construct**

One of the following: data class, storage class, management class, storage group, aggregate group, base configuration.

**cross-coupling facility (XCF)**

A component of the MVS operating system that provides functions to support cooperation between authorized programs running within a sysplex.

**DASD**

Direct access storage device.

**DASD volume**

A DASD space identified by a common label and accessed by a set of related addresses.

**data class**

A collection of allocation and space attributes, defined by the storage administrator, that is used to create a data set.

**Data Facility Sort (DFSORT)**

An IBM-licensed program that is a high-speed data processing utility. DFSORT provides an efficient and flexible way to handle sorting, merging, and copying operations, as well as providing versatile data manipulation at the record, field, and bit level.

**Data Facility Storage Management Subsystem (DFSMS)**

An operating environment that helps automate and centralize the management of storage. To manage storage, SMS provides the storage administrator with control over data class, storage class,

management class, storage group, and automatic class selection routine definitions.

**data set**

The major unit of data storage and retrieval in z/OS DFSMS, consisting of a collection of data in a prescribed arrangement and described by control information to which the system has access.

**DDR** Dynamic device reconfiguration.

**device** This term is used interchangeably with unit. You mount a tape on a unit or device, such as a 3490.

**device category**

A storage device classification used by SMS. The device categories are as follows  
SMS-managed DASD, SMS-managed tape,  
non-SMS-managed DASD  
non-SMS-managed tape.

**DFSMS**

See *Data Facility Storage Management Subsystem*.

**DFSMSdfp**

DFSMS data facility product. A z/OS DFSMS functional component that provides functions for storage management, data management, program management, device management, and distributed data access.

**DFSMSdss**

DFSMS data set services. A z/OS DFSMS functional component that provides functions for copying, moving, dumping, and restoring data sets and volumes.

**DFSMShsm**

DFSMS hierarchical storage manager. A z/OS DFSMS functional component that provides functions for backing up and recovering data, and managing space on volumes in the storage hierarchy.

**DFSMShsm-managed volume**

(1) A primary storage volume, which is defined to DFSMShsm but which does not belong to a storage group. (2) A volume in a storage group, which is using DFSMShsm automatic dump, migration, or backup services. Contrast with *system-managed volume* and *DFSMSrmm-managed volume*.

- DFSMSrmm**  
DFSMS removable media manager. A z/OS DFSMS functional component that provides functions for managing removable media.
- DFSMSrmm control data set**  
A VSAM key-sequenced data set that contains the complete inventory of your removable media library, as well as the movement and retention policies you define. In the control data set, DFSMSrmm records all changes made to the inventory, such as adding or deleting volumes.
- DFSMSrmm-managed volume**  
A tape volume that is defined to DFSMSrmm. Contrast with *system-managed volume* and *DFSMSHsm-managed volume*.
- DFSORT**  
Data Facility Sort.
- EEFMT2**  
Enterprise encrypted format 2 recording technology
- EEFMT3**  
Enterprise encrypted format 3 recording technology
- EEFMT4**  
Enterprise encrypted format 4 recording technology
- EFMT1**  
Enterprise format 1 recording technology
- EFMT2**  
Enterprise format 2 recording technology
- EFMT3**  
Enterprise format 3 recording technology
- EFMT4**  
Enterprise format 4 recording technology
- ERDS** Error recording data set
- enhanced capacity cartridge system tape**  
Cartridge system tape with increased capacity that can only be used with 3490E Magnetic Tape Subsystems. Contrast with *cartridge system tape*.
- Enterprise Tape Cartridge**  
Cartridge system tape with increased capacity that can only be used with 3592 Magnetic Tape Subsystems (MEDIA5, MEDIA6, MEDIA7, MEDIA8, MEDIA9, MEDIA10, MEDIA11, MEDIA12, and MEDIA13). Contrast with *cartridge system tape*.
- EREP** Environmental Recording, Editing, and Printing.
- ESCON**  
Enterprise systems connection.
- file** A collection of information treated as a unit. In non-OS/390 UNIX environments, the terms *data set* and *file* are generally equivalent and are sometimes used interchangeably. See also *data set*.
- GB** GB = 1,000,000,000 bytes for tape storage capacity.
- hardware configuration definition**  
An interactive interface in the MVS system that enables an installation to define hardware configurations from a single point of control.
- HCD** Hardware configuration definition.
- IBM TotalStorage Enterprise Tape Cartridge**  
A Cartridge system tape with increased capacity that can only be used with 3592 Magnetic Tape Subsystems (MEDIA5, MEDIA6, MEDIA7, MEDIA8, MEDIA9, and MEDIA10).
- Interactive Storage Management Facility (ISMF)**  
The interactive interface of z/OS DFSMS that allows users and storage administrators access to the storage management functions.
- IOS** Input/output supervisor.
- IPL** Initial program load.
- ISMF** Interactive storage management facility.
- JCL** Job control language.
- JES** Job Entry Subsystem .
- keyword**  
A predefined word that is used as an identifier.
- LDG** Library device group.
- manual tape library (MTL)**  
An installation-defined set of stand-alone tape drives and the set of tape volumes that can be mounted on those drives.
- MEDIA5**  
IBM Enterprise Tape Cartridge.

**MEDIA6**  
IBM Enterprise WORM Tape Cartridge.

**MEDIA7**  
IBM Enterprise Economy Tape Cartridge.

**MEDIA8**  
IBM Enterprise Economy WORM Tape Cartridge.

**MEDIA9**  
IBM Enterprise Extended Tape Cartridge.

**MEDIA10**  
IBM Enterprise Extended WORM Tape Cartridge.

**MEDIA11**  
IBM Enterprise Advanced Tape Cartridge.

**MEDIA12**  
IBM Enterprise Advanced WORM Tape Cartridge.

**MEDIA13**  
IBM Enterprise Advanced Economy Tape Cartridge.

**MB** MB = 1,000,000 bytes for tape storage capacity.

**MTL** Manual tape library.

**MVS** Multiple virtual storage.

**MVSCP**  
Multiple virtual storage configuration program.

**MVS/ESA**  
An environment in the MVS operating system that supports ESA/390.

**OAM** Object access method.

**OAM complex (OAMplex)**  
One or more instances of OAM running on systems that are part of a Parallel Sysplex. The OAM systems that are part of an OAMplex share a common OAM database in a DB2 data-sharing group.

**OAM-managed volumes**  
Optical or tape volumes controlled by the object access method (OAM).

**object access method (OAM)**  
An access method that provides storage, retrieval, and storage hierarchy management for objects and provides storage and retrieval management for tape volumes contained in system-managed libraries.

**OCDB**  
Optical configuration database.

**O/C/EOV**  
Open/close/end-of-volume.

**OS/390**  
Operating System/390.

**performance**  
(1) A measurement of the amount of work a product can produce with a given amount of resources. (2) In a DFSMS environment, a measurement of effective data processing speed with respect to objectives set by the storage administrator. Performance is largely determined by throughput, response time, and system availability.

**performance scaling**  
Formatting a tape so that less than its full capacity is used. Formatting a tape to its optimal performance capacity decreases the amount of time required to access the data on the tape. A tape that is formatted to its optimal performance capacity can later be reused and formatted to its full capacity. This applies only to MEDIA5, MEDIA9, and MEDIA11 tape cartridge media.

**performance segmentation**  
Formatting a tape into a fast access segment to be filled first, and a slower access segment to be filled after. This applies only to MEDIA5, MEDIA9, and MEDIA11 tape cartridge media.

**private tape volume**  
A volume assigned to specific individuals or functions.

**product support plan (PSP) bucket**  
Contains the instructions and the PTFs for effectively migrating to a new software release.

**PSP bucket**  
Product support plan bucket.

**PTF** Program temporary fix.

**recording format**  
For a tape volume, the format of the data on the tape; for example, 18, 36, 128, 256, 384 tracks, EFMT1, EFMT2, EEFMT2, EFMT3, EEFMT3, EFMT4, or EEFMT4.

**recovery**  
The process of rebuilding data after it has

- been damaged or destroyed, often by using a backup copy of the data or by reapplying transactions recorded in a log.
- REXX** Restructured extended executor.
- SCDS** Source control data set.
- scratch**  
The status of a tape volume that is available for general use, because the data on it is incorrect or is no longer needed. You request a scratch volume when you omit the volume serial number on a request for a tape volume mount.
- scratch volume**  
A tape volume that contains expired data only. See *scratch*.
- SCSI** Small computer system interface.
- SFI** Structured field introducer.
- storage administrator**  
A person in the data processing center who is responsible for defining, implementing, and maintaining storage management policies.
- storage class**  
A collection of storage attributes that identify performance goals and availability requirements, defined by the storage administrator, used to select a device that can meet those goals and requirements.
- storage group**  
A collection of storage volumes and attributes, defined by the storage administrator. The collections can be a group of DASD volumes or tape volumes, or a group of DASD, optical, or tape volumes treated as a single object storage hierarchy. See also *tape storage group*.
- storage management**  
The activities of data set allocation, placement, monitoring, migration, backup, recall, recovery, and deletion. These can be done either manually or by using automated processes. The Storage Management Subsystem automates these processes for you, while optimizing storage resources. See also *Storage Management Subsystem*.
- Storage Management Subsystem (SMS)**  
A z/OS DFSMS facility used to automate and centralize the management of storage.
- Using SMS, a storage administrator describes data allocation characteristics, performance and availability goals, backup and retention requirements, and storage requirements to the system through data class, storage class, management class, storage group, and ACS routine definitions.
- storage subsystem**  
A storage control and its attached storage devices. See also *tape subsystem*.
- subsystem**  
A special MVS task that provides services and functions to other MVS users. Requests for service are made to the subsystem through a standard MVS facility known as the subsystem interface (SSI). Standard MVS subsystems are the master subsystem and the job entry subsystems JES2 and JES3.
- system-managed storage**  
Storage managed by the Storage Management Subsystem. SMS attempts to deliver required services for availability, performance, and space to applications.
- SVC** Supervisor call
- system-managed tape library**  
A collection of tape volumes and tape devices, defined in the tape configuration database. A system-managed tape library can be automated or manual. See also *tape library*.
- tape configuration database (TCDB)**  
One or more volume catalogs used to maintain records of system-managed tape libraries and tape volumes.
- tape library**  
A set of equipment and facilities that support an installation's tape environment. This can include tape storage racks, a set of tape drives, and a set of related tape volumes mounted on those drives. See also *system-managed tape library*.
- tape storage group**  
A type of storage group that contains system-managed private tape volumes. The tape storage group definition specifies the system-managed tape libraries that can contain tape volumes. See also *storage group*.

**tape subsystem**

A magnetic tape subsystem consisting of a controller and devices, which allows for the storage of user data on tape cartridges.

**tape volume**

A tape volume is the recording space on a single tape cartridge or reel. See also *volume*.

**TCDB** Tape configuration database.

**TSO** Time-sharing option.

**TS1120**

IBM System Storage TS1120 (3592 Model E05, 3592-2 and 3592-2E) .

**TS1130**

IBM System Storage TS1130 (3592 Model E06, 3592-3E) .

**TS1140**

IBM System Storage TS1140 (3592 Model E07, 3592-4E) .

**VOLSER**

Volume serial number.

**volume**

The storage space on DASD, tape, or optical devices, which is identified by a volume label.

**volume serial number (VOLSER)**

An identification number in a volume label that is assigned when a volume is prepared for use on the system. For standard label volumes, the volume serial number is the VOL1 label of the volume. For volumes without labels, the volume serial number is the name the user assigns to the volume.

**world-wide identifier (WWID)**

Often used in z/OS software as the abbreviation for the world-wide unique cartridge identifier (WWCID). See also *world-wide unique cartridge identifier*.

**world-wide unique cartridge identifier (WWCID)**

A permanent identifier associated with a specific tape cartridge, typically stored on the tape itself and the non-volatile cartridge memory.

**Write Once, Read Many (WORM)**

A technology to allow data to be written once to storage media. After that, data is

permanent and cannot be altered, but can be read any number of times.

**WWCID**

See world-wide unique cartridge identifier.

**WWID**

See world-wide identifier.

# Index

## Numerics

- 3590-1 Generic Unit
  - using mixed track technology drives 59, 139, 232
- 3592 Model E05 261
  - introduction for 261
- 3592 Model J tape drive
  - introduction for 339
- 3592 Tape Drive
  - 3592 Model E05
    - migration tasks 274, 279
  - encryption-capable TS1120 tape drive
    - migration tasks 191, 198
  - Model J
    - migration tasks 357
  - Model Jx
    - migration tasks 350
  - TS1130 tape drive
    - migration tasks 109
  - TS1130 tape drives
    - migration tasks 102
  - TS1140 tape drive
    - migration tasks 26
  - TS1140 tape drives
    - migration tasks 18

## A

- access method services (AMS)
  - modifications for 3592 Model E05 283
  - modifications for 3592 Model J 361
  - modifications for TS1120 tape drives 203
  - modifications for TS1130 tape drives 113
  - modifications for TS1140 tape drives 31
- accessibility 417
  - contact IBM 417
  - features 417
- ACS (automatic class selection)
  - allocation to 3592 Model E05 280
  - allocation to 3592 Model J 357
  - allocation to encryption-capable TS1120 tape drive 200
  - allocation to TS1130 tape drives 110
  - allocation to TS1140 tape drives 27
- ADDVOLUME
  - KEYENCODE1 239
  - KEYENCODE2 239
  - KEYLABEL1 239
  - KEYLABEL2 239
  - MEDIATYPE
    - MEDIA10 145, 239, 318
    - MEDIA11 61
    - MEDIA12 61
    - MEDIA13 61
    - MEDIA5 145, 239, 318
    - MEDIA6 145, 239, 318

- ADDVOLUME (*continued*)
    - MEDIATYPE (*continued*)
      - MEDIA7 145, 239, 318
      - MEDIA8 145, 239, 318
      - MEDIA9 145, 239, 318
    - RECORDINGFORMAT
      - EEFMT2 145, 239
      - EEFMT3 145
      - EEFMT4 61
      - EFMT1 239, 318
      - EFMT2 239, 318
      - EFMT3 145
      - EFMT4 61
  - ADREID0 mapping macro
    - changes for encryption-capable TS1120 tape drive 237
    - changes for TS1130 tape drive 131
  - ALTER LIBRARYENTRY
    - for TS1140 tape drive 31
  - NUMBEREMPTYSLOTS
    - parameter 31
  - NUMBERSCRATCHVOLUMES
    - parameter 31
  - NUMBERSLOTS parameter 31
  - SCRATCHTHRESHOLD
    - parameter 31
  - ALTER LIBRARYENTRY command
    - example
      - for 3592 Model E05 285
    - examples 363
    - parameters 363
      - optional 291, 368
    - parameters for 3592 Model E05 285
  - ALTER VOLUMEENTRY
    - EFMT1 361
    - EFMT2 for 3592 Model E05 283
    - RECORDING parameter 283, 361
  - ALTER VOLUMEENTRY command
    - EEFMT2 Support 203
    - EFMT1 364
    - EFMT2 for 3592 Model E05 286
    - EFMT2 for encryption-capable TS1120 tape drive 203
    - EFMT3 and EEFMT3 support 113
    - EFMT4 and EEFMT4 support 32
    - RECORDING parameter 203, 286, 364
      - EFMT3 and EEFMT3 support 113
      - EFMT4 and EEFMT4 support 32
    - TS1130 support 113
    - TS1140 support 32
- AMS
  - ALTER LIBRARYENTRY 283, 361
    - for TS1140 tape drive 31
  - ALTER VOLUMEENTRY 203, 286, 363, 364
    - EFMT3 and EEFMT3 support 113
    - EFMT4 and EEFMT4 support 32
  - CREATE LIBRARYENTRY 366
    - for 3592 Model E05 289
    - for TS1140 tape drive 32

## AMS (*continued*)

- CREATE VOLUMEENTRY 204, 292, 369
  - EFMT3 and EEFMT3 support 114
  - EFMT4 and EEFMT4 support 33
- DCOLLECT 371
  - for 3592 Model E05 295
  - for encryption-capable TS1120 tape drive 204
  - for TS1130 114
  - for TS1140 34
- LISTCAT 373
  - for 3592 Model E05 297
  - for encryption-capable TS1120 tape drive 204
  - for TS1130 tape drive 115
  - for TS1140 tape drive 34
- API structured field introducers 67, 150, 244, 320, 395
- assistive technologies 417

## B

- BLK6 ('80D0B0') - Total block count 68
- BLKT ('80D030') - Total block count 68

## C

- CBRSMKBO SAMPLIB member 162
- CBRTDSI mapping macro 25, 108, 197, 278, 355
- CBRTVI mapping macro 25, 108, 197, 278, 355
- CBRUXCPL mapping macro 25, 108, 197, 278, 355
- CBRUXCUA exit 25, 108, 197, 278, 355
- CBRUXEJC exit 25, 108, 197, 278, 355
- CBRUXENT exit 25, 108, 197, 278, 355
- CBRUXEPL mapping macro 25, 108, 197, 278, 355
- CBRUXNPL mapping macro 25, 108, 197, 278, 355
- CHANGEVOLUME
  - KEYENCODE1 241
  - KEYENCODE2 241
  - KEYLABEL1 241
  - KEYLABEL2 241
  - MEDIATYPE
    - MEDIA10 145, 241, 319
    - MEDIA11 62
    - MEDIA12 62
    - MEDIA13 62
    - MEDIA5 62, 145, 241, 319, 394
    - MEDIA6 62, 145, 241, 319, 394
    - MEDIA7 62, 145, 241, 319, 394
    - MEDIA8 145, 241, 319, 394
    - MEDIA9 145, 241, 319
  - NOKEYLABEL1 241
  - NOKEYLABEL2 241

- CHANGEVOLUME (*continued*)
- RECORDINGFORMAT
    - EEFMT2 145, 241
    - EEFMT3 145
    - EEFMT4 62
    - EFMT1 145, 241, 319, 394
    - EFMT2 145, 241, 319
    - EFMT3 145
    - EFMT4 62
  - coexistence considerations 347
    - for 3592 Model E05 271
    - for encryption-capable TS1120 tape drive 187
    - for TS1130 tape drive 99
    - for TS1140 tape drive 15
  - command
    - syntax conventions xvii
  - commands
    - ADDVOLUME 61, 145, 239, 318, 393
    - ALTER LIBRARYENTRY 283, 361
      - for TS1140 tape drive 31
    - ALTER VOLUMEENTRY 203, 286, 363, 364
      - EFMT3 and EEFMT3 support 113
      - EFMT4 and EEFMT4 support 32
    - CHANGEVOLUME 62, 145, 241, 319, 394
    - CREATE LIBRARYENTRY 366
      - for 3592 Model E05 289
      - for TS1140 tape drive 32
    - CREATE VOLUMEENTRY 204, 292, 369
      - EFMT3 and EEFMT3 support 114
      - EFMT4 and EEFMT4 support 33
    - DCOLLECT 371
      - for 3592 Model E05 295
      - for encryption-capable TS1120 tape drive 204
      - for TS1130 114
      - for TS1140 34
    - DFSMSdss BUILDSA command 237
    - DFSMSdss COPYDUMP command 237
    - DFSMSdss DUMP command 236
    - DFSMSdss RESTORE command 237
    - LISTCAT 373
      - for 3592 Model E05 297
      - for encryption-capable TS1120 tape drive 204
      - for TS1130 tape drive 115
      - for TS1140 tape drive 34
    - LISTDATASET 65, 148
    - LISTVOLUME 66, 148, 243
    - SEARCHVOLUME 63, 146, 242, 319, 395
  - compound SFI 69, 151
  - Compression Ratio SFI 68
  - conflicts in recording technology, resolving
    - for 3592 268
    - for TS1120 183
    - for TS1130 97
    - for TS1140 12
  - CRAT ('817890') - Compression Ratio 68
  - CREATE LIBRARYENTRY
    - for TS1140 tape drive 32
  - CREATE LIBRARYENTRY (*continued*)
    - NUMBEREMPTYSLOTS
      - parameter 32
    - NUMBERSCRATCHVOLUMES
      - parameter 32
    - NUMBERSLOTS parameter 32
    - SCRATCHTHRESHOLD
      - parameter 32
  - CREATE LIBRARYENTRY command
    - examples 368
      - for 3592 Model E05 291
    - format 366
      - for 3592 Model E05 289
  - CREATE VOLUMEENTRY
    - command syntax 369
  - CREATE VOLUMEENTRY command
    - examples 371
      - for 3592 Model E05 294
      - for TS1130 114
      - for TS1140 33
    - format 369
      - EFMT3 and EEFMT3 support 114
      - EFMT4 and EEFMT4 support 33
      - for 3592 Model E05 292
      - for encryption-capable TS1120 tape drive 204
      - for TS1130 114
      - for TS1140 33
- ## D
- DALINCHG
    - DALINCHG text unit 123, 214, 304, 381
      - EFMT1 123, 214, 304, 381
    - DALINCHG text unit
      - for TS1120 216
      - for TS1130 43, 124
    - DALKYC1 text unit 216
    - DALKYC2 text unit 216
    - DALKYL1 text unit 216
    - DALKYL2 text unit 216
    - DASD 37, 117, 207, 299, 377
    - data class
      - using encryption-capable TS1120 tape drive 227, 235
      - using TS1130 tape drive 133
      - using TS1140 tape drive 53
    - Data Set Size Factor SFI 151
    - DDCMEDIA parameter
      - DCOLLECT command 372
        - for 3592 Model E05 296
    - DDCRECTE parameter
      - DCOLLECT command 373
        - for 3592 Model E05 296
    - defining library group names in a JES3plex 75, 155, 249, 327, 405
    - device support 37, 117, 207, 299, 377
    - DEVSERV QTAPE MED
      - sample messages 37, 117, 207, 299, 377
      - sample output 37, 117, 207, 299, 377
      - Syntax 37, 117, 207, 299, 377
    - DEVSUPxx parmlib member
      - options 386
  - DFSMSdss
    - application programming interface (API) 131
      - change to Exit 26 237
    - BUILDSA command 237
    - considerations for encryption-capable TS1120 tape drive 235
    - considerations for TS1130 tape drive 131
    - considerations for TS1140 tape drive 51
    - COPYDUMP command 237
    - double encryption 237
    - handling of dump encryption requests 236
    - planning to use encryption-capable TS1120 tape drive 235
    - Stand Alone Restore program 237
  - DFSMSShsm
    - considerations for encryption-capable TS1120 tape drive 227
    - considerations for TS1130 tape drive 133
    - considerations for TS1140 tape drive 53
    - implementation 359
      - for 3592 Model E05 281
      - for encryption-capable TS1120 tape drive 201
      - for TS1130 tape drives 112
      - for TS1140 tape drives 28
    - managing spanning data sets 60, 139, 233, 313, 390
    - modifications
      - for 3592 Model E5 tape drive 311
    - output tape selection 389
    - TAPEUTILIZATION
      - PERCENTFULL 389
      - tips 60, 139, 233, 313, 390
  - DFSMSShsm dump class
    - using encryption-capable TS1120 tape drive 235
  - DFSMSShsm LIST command 54, 134, 228
  - DFSMSrmm
    - API structured field introducer (SFI) 67, 150, 244, 320, 395
    - mapping macros 69, 152, 245, 320, 396
    - reason codes 397
    - return codes 397
    - REXX variables 67, 149, 244, 320, 395
  - DFSMSrmm media names 318, 394
  - DFSMSrmm TSO subcommand
    - ADDVOLUME 61, 145, 239, 318, 393
    - CHANGEVOLUME 62, 145, 241, 319, 394
    - LISTDATASET 65, 148
    - LISTVOLUME 66, 148, 243
    - SEARCHVOLUME 63, 146, 242, 319, 395
  - DFSMSrmm TSO subcommands
    - updates for TS1140 61
  - double encryption
    - method for allowing 236
  - dsname allocation text unit 43, 124, 215
  - DSS6 67, 150



DSS6 ('82B030') - Data Set Size  
 Factor 151  
 dump class  
   using encryption-capable TS1120 tape  
   drive 227  
   using TS1130 tape drive 133  
   using TS1140 tape drive 53  
 dynamic allocation (DALINCHG)  
   DALINCHG text unit 42  
   parameter values for media types 42

## E

EDG@KEL1 244  
 EDG@KEL2 244  
 EDG@KEM1 244  
 EDG@KEM2 244  
 EDG@MEDR 67, 149, 244, 320  
 EDG@MEDT 320  
 EDGCLREC 69, 152, 245, 320  
 EDGDREC 69, 152  
 EDGEXTSY 69, 152, 245, 320, 396  
 EDGPL100 320  
 EDGRDEXT 69, 152, 396  
 EDGRVEXT 69, 152, 245, 320  
 EDGRXEXT 69, 152, 245, 320, 396  
 EDGSMFSY 69, 152, 245, 320, 396  
 EDGSVREC 69, 152, 245, 320, 396  
 EEFMT2  
   ADDVOLUME 239  
   CHANGEVOLUME 145, 241  
   SEARCHVOLUME 146, 242  
 EEFMT3  
   ADDVOLUME 145  
   CHANGEVOLUME 145  
   SEARCHVOLUME 146  
 EEFMT4  
   ADDVOLUME 61  
   CHANGEVOLUME 62  
   SEARCHVOLUME 63  
 EFMT1 288, 294, 365, 371  
   ADDVOLUME 239, 318  
   CHANGEVOLUME 145, 241, 319  
   SEARCHVOLUME 146, 242, 319  
 EFMT2  
   ADDVOLUME 239, 318  
   CHANGEVOLUME 145, 241, 319  
   SEARCHVOLUME 146, 242, 319  
 EFMT3  
   ADDVOLUME 145  
   CHANGEVOLUME 145  
   SEARCHVOLUME 146  
 EFMT4  
   ADDVOLUME 61  
   CHANGEVOLUME 62  
   SEARCHVOLUME 63  
 EI00CANSFE bit  
   added to ADREID0 mapping  
   macro 131  
 EI00MIXDEV bit  
   added to ADREID0 mapping  
   macro 131  
 EI00SWNCRYPT bit  
   added to ADREID0 mapping  
   macro 131

EI26TWHE bit  
   added to ADREID0 mapping  
   macro 237  
 emulated device summary report  
   emulated device type 73, 153, 324,  
   402  
 encryption  
   of dumps 51, 53, 131, 133, 227, 235  
   of tapes 3, 89, 170  
 encryption-capable TS1120 tape  
 drive 169  
   DFSMSdsss considerations 235  
   DFSMSdsss planning 235  
   DFSMSHsm considerations 227  
   introduction for 169  
   media support for 176  
 EREP  
   emulated device summary report 73,  
   153, 247, 323, 401  
   ERDS records 73, 153, 247, 323, 401  
   event history report 247, 323, 401  
   for 3592 Model E05 323  
   for 3592 Model E06 153  
   for encryption-capable TS1120 tape  
   drive 247  
   for TS1140 tape drive 73  
   IBM service representatives 73, 153,  
   247, 323, 401  
   system error summary report 247,  
   323, 401  
   TAPE Media Informational Messages  
   (MIMs) 73, 153  
   TAPE subsystem exception report 73,  
   153  
 Error recovery procedure routines 37,  
 117, 207, 299, 377  
 event history report  
   3590 323, 401  
   3592 Model E05 323  
   native device type 323, 401  
 EXCP 37, 117, 207, 299, 377  
 Exit 26  
   change to ADREID0 mapping  
   macro 237

## H

HSMplex consideration  
   for 3592-2 tape drives 311

## I

IBM Security Key Lifecycle Manager 6  
 IBM System Storage  
   3592 Model E05 274, 279  
   3592 Model J 357  
   3592 Model Jx 350  
   encryption-capable TS1120 tape  
   drive 176, 191, 198  
   TS1130 tape drive 92, 109  
   TS1130 tape drives 102  
   TS1140 tape drive 7, 26  
   TS1140 tape drives 18  
 IBM System Storage Tape System  
   3592 261, 339  
   3592 Model E05 tape drive 261

IBM System Storage Tape System 3592  
 (continued)  
   3592 Model J tape drive 339  
   software support  
     for 3592 Model E05 265  
     for encryption-capable TS1120 tape  
     drive 10, 95, 180  
   software support for 341  
   tape drive  
     3592 Model J 339  
   WORM 340  
     for 3592 Model E05 263  
 IBM tape library  
   customization 353  
     for 3592 Model E05 277  
     for encryption-capable TS1120 tape  
     drive 196  
     for TS1130 tape drives 23, 107  
   implementation 357  
   implementation for 3592 Model  
   E05 280  
   implementation for encryption-capable  
   TS1120 tape drive 200  
   implementation for TS1130 tape  
   drives 110  
   implementation for TS1140 tape  
   drives 27  
   planning for 20, 104, 193, 275, 351  
   using 3592 Model E05 tape  
   drives 267  
   using 3592 Model J tape drives 343  
   using encryption-capable TS1120 tape  
   drives 182  
   using TS1130 tape drives 97  
   using TS1140 tape drives 11  
 IECLOGT macro 380  
 IECLOGT mapping macro 25, 108, 197,  
 278, 355  
 IEEOEVSE mapping macro 25, 108, 197,  
 278, 355  
 IECSNST macro 25, 108, 197, 278, 355  
 IECUCBCX macro 25, 108, 197, 209, 278,  
 301, 355, 379  
 IFGTPE macro 386  
 IFGWAX mapping macro 25, 108, 197,  
 278, 355  
 IHADFVT macro 25, 108, 197, 278, 355,  
 379  
 in-band tape encryption  
   administration tasks for 257  
 information center  
   IBM System Storage 3592-C07  
   Controller xv  
   IBM System Storage TS1140 Tape  
   Drive xv  
 input tape use  
   non-SMS input tape use 54, 134, 228,  
   311  
   SMS output tape use 54, 134, 228,  
   311  
 IOS 37, 117, 207, 299, 377  
 ISMF  
   data class  
     for 3592 Model E05 305  
     for 3592 Model J 383  
     for TS1120 219  
     for TS1130 125

ISMF (*continued*)  
 data class (*continued*)  
   for TS1140 45  
 mountable tape volume  
   for 3592 Model E05 305  
   for 3592 Model J 383  
   for TS1120 219  
   for TS1130 125  
   for TS1140 45

## J

JCL DD statement parameters  
 equivalent text units  
   for TS1120 215  
 JES3  
 library device group 75, 155, 249,  
 327, 405  
 modifications for 3592 Model  
 E05 327  
 modifications for encryption-capable  
 TS1120 tape drive 249  
 modifications for TS1130 tape  
 drive 155  
 modifications for TS1140 tape  
 drive 75

## K

KEL1 244  
 KEL2 244  
 KEM1 244  
 KEM2 244  
 keyboard  
   navigation 417  
   PF keys 417  
   shortcut keys 417  
 KEYENCODE1  
   ADDVOLUME 239  
 KEYENCODE2  
   ADDVOLUME 239  
 KEYLABEL1  
   ADDVOLUME 239  
 KEYLABEL2  
   ADDVOLUME 239

## L

list tape volume entries sample output  
 EEFMT2 subparameter 205  
 EFMT3 and EEFMT3  
   subparameters 115  
 EFMT4 and EEFMT4  
   subparameters 35  
 LIST TIOC command  
   for EEFMT2 formatted tapes 229  
   for EEFMT3 formatted tapes 135  
   for EEFMT4 formatted tapes 55  
   for EFMT2 formatted tapes 313  
   for EFMT3 formatted tapes 135  
   for EFMT4 formatted tapes 55  
 LISTCAT output  
   for 3592 Model E05 298  
   for 3592 Model J 374

## M

mapping macros  
 CBRTDSI 355  
   for 3592 Model E05 278  
   for encryption-capable TS1120 tape  
   drive 197  
   for TS1130 tape drives 108  
   for TS1140 tape drives 25  
 CBRTVI 355  
   for 3592 Model E05 278  
   for encryption-capable TS1120 tape  
   drive 197  
   for TS1130 tape drives 108  
   for TS1140 tape drives 25  
 CBRUXCPL 355  
   for 3592 Model E05 278  
   for encryption-capable TS1120 tape  
   drive 197  
   for TS1130 tape drives 108  
   for TS1140 tape drives 25  
 CBRUXEPL 355  
   for 3592 Model E05 278  
   for encryption-capable TS1120 tape  
   drive 197  
   for TS1130 tape drives 108  
   for TS1140 tape drives 25  
 CBRUXNPL 355  
   for 3592 Model E05 278  
   for encryption-capable TS1120 tape  
   drive 197  
   for TS1130 tape drives 108  
   for TS1140 tape drives 25  
 EDGCLREC 69, 152, 245, 320  
 EDGEXTSY 69, 152, 245, 320, 396  
 EDGPL100 320  
 EDGRDEXT 69, 152, 396  
 EDGRVEXT 69, 152, 245, 320  
 EDGRXEXT 69, 152, 245, 320, 396  
 EDGSDREC 69, 152  
 EDGSMFSY 69, 152, 245, 320, 396  
 EDGSVREC 69, 152, 245, 320, 396  
 IECLOGT 355, 380  
   for 3592 Model E05 278  
   for encryption-capable TS1120 tape  
   drive 197  
   for TS1130 tape drives 108  
   for TS1140 tape drives 25  
 IECEOVSE 355  
   for 3592 Model E05 278  
   for encryption-capable TS1120 tape  
   drive 197  
   for TS1130 tape drives 108  
   for TS1140 tape drives 25  
 IECUCBCX 209, 301, 379  
 IFGTEP 386  
 IFGWAX 355  
   for 3592 Model E05 278  
   for encryption-capable TS1120 tape  
   drive 197  
   for TS1130 tape drives 108  
   for TS1140 tape drives 25  
 IHADFTV 379  
 Media Recording Format SFI 68, 151  
 media support  
   for encryption-capable TS1120 tape  
   drive 176  
   for TS1130 tape drive 92

media support (*continued*)  
   for TS1140 tape drive 7  
 Media Type SFI 68  
 MEDIA10  
   ADDVOLUME 239, 318  
   CHANGEVOLUME 145, 241, 319  
   SEARCHVOLUME 63, 146, 242, 319  
 MEDIA11  
   CHANGEVOLUME 62  
   SEARCHVOLUME 63  
 MEDIA12  
   CHANGEVOLUME 62  
   SEARCHVOLUME 63  
 MEDIA13  
   CHANGEVOLUME 62  
 MEDIA5  
   ADDVOLUME 239, 318  
   CHANGEVOLUME 145, 241, 319  
   SEARCHVOLUME 146, 242, 319  
 MEDIA6  
   ADDVOLUME 239, 318  
   CHANGEVOLUME 145, 241, 319  
   SEARCHVOLUME 146, 242, 319  
 MEDIA7  
   ADDVOLUME 239, 318  
   CHANGEVOLUME 145, 241, 319  
   SEARCHVOLUME 146, 242, 319  
 MEDIA8  
   ADDVOLUME 239, 318  
   CHANGEVOLUME 145, 241, 319  
   SEARCHVOLUME 146, 242, 319  
 MEDIA9  
   ADDVOLUME 239, 318  
   CHANGEVOLUME 145, 241, 319  
   SEARCHVOLUME 146, 242, 319  
 MEDIATYPE  
   MEDIA10 288, 294  
   MEDIA5 288, 294, 365, 371  
   MEDIA6 288, 294, 365, 371  
   MEDIA7 288, 294, 365, 371  
   MEDIA8 288, 294, 365, 371  
   MEDIA9 288, 294  
 MEDIATYPE parameter  
   ALTER VOLUMEENTRY  
     command 364, 370  
     for 3592 Model E05 287, 293  
 MEDR 67, 150, 244, 320  
 MEDR ('857000') - Media Recording  
   Format 68, 151  
 MEDT 320  
 MEDT ('858000') - Media Type 68  
 messages 356  
   updates for 3592 Model E05 279  
   updates for encryption-capable TS1120  
   tape drive 197  
   updates for TS1130 tape drive 108  
   updates for TS1140 tape drive 25  
 migration information 347  
   for 3592 Model E05 271  
   for encryption-capable TS1120 tape  
   drive 187  
   for TS1130 tape drive 99  
   for TS1140 tape drive 15  
 mixed track technology drives  
   allowing DFSMSHsm to use 59, 139,  
   232

MVS device allocation 37, 117, 207, 299, 377  
 batch (JCL) 41, 122, 214, 303, 380  
 dynamic (SVC99) allocation 41, 122, 214, 303, 380  
 LIBSERV 41, 122, 214, 303, 380  
 MSGDISP 41, 122, 214, 303, 380  
 OAM 41, 122, 214, 303, 380  
 SMS 41, 122, 214, 303, 380

## N

navigation  
 keyboard 417  
 notational conventions xvi  
 Notices 421  
 NUMBERSCRATCHVOLUMES  
 parameter  
 ALTER LIBRARYENTRY  
 command 362, 367  
 for 3592 Model E05 284, 289

## O

O/C/EOV  
 IFGTEP macro 47, 127, 221, 307, 385  
 recording technology conflict 47, 127, 221, 307, 385

### OAM

for 3592 Model E05 329, 334  
 for encryption-capable TS1120 tape drive 251, 254  
 for TS1130 tape drive 157, 160  
 for TS1140 tape drive 77, 81  
 library support 77, 157, 251, 329, 407  
 object tape support 81, 160, 254, 334, 411

OAM modifications  
 for 3592 Model E05 329  
 for 3592 Model J 407  
 for encryption-capable TS1120 tape drive 251  
 for TS1130 tape drive 157  
 for TS1140 tape drive 77

### OAMplex

coexistence considerations 349  
 for 3592 Model E05 273  
 for encryption-capable TS1120 tape drive 190  
 for TS1130 tape drives 101  
 for TS1140 tape drives 17

customization 354  
 for 3592 Model E05 277  
 for encryption-capable TS1120 tape drive 196  
 for TS1130 tape drives 107  
 for TS1140 tape drives 23

implementation 358  
 for 3592 Model E05 281  
 for encryption-capable TS1120 tape drive 201  
 for TS1130 tape drives 28, 111

planning for 352  
 for 3592 Model E05 275  
 for encryption-capable TS1120 tape drive 194

OAMplex (*continued*)  
 planning for (*continued*)  
 for TS1130 tape drives 21, 105

output tape selection  
 non-SMS output tape selection  
 SMS ACS routine 58, 138, 231, 312, 389

SMS output tape selection  
 SMS cartridge eligibility 58, 138, 231, 312, 389

## P

parmlib  
 VLPOOL MASTEROVERWRITE  
 operand 397

performance scaling  
 for 3592 264  
 for TS1120 179  
 for TS1130 95  
 for TS1140 9

performance segmentation  
 for 3592 264  
 for TS1120 179  
 for TS1130 95  
 for TS1140 9

Physical space used SFI 68  
 PSZ6 ('87D300') - Physical space used 68

## R

required product knowledge xv  
 resolving recording technology conflicts  
 for 3592 268  
 for TS1120 183  
 for TS1130 97  
 for TS1140 12

reuse capacity table  
 MEDIA10 313  
 MEDIA7 390  
 MEDIA9 313

## S

scaling  
 for 3592 264  
 for TS1120 179  
 for TS1130 95  
 for TS1140 9

scratch tapes  
 non-SMS input tape use  
 SMS ACS routine 232, 312  
 SMS output tape use  
 SMS cartridge eligibility 232, 312

SCRATCHTHRESHOLD parameter  
 ALTER LIBRARYENTRY  
 command 362, 367  
 for 3592 Model E05 284, 290

SEARCHVOLUME  
 MEDIATYPE  
 MEDIA10 146, 242, 319  
 MEDIA11 63  
 MEDIA12 63  
 MEDIA13 63  
 MEDIA5 146, 242, 319, 395  
 MEDIA6 146, 242, 319, 395

### SEARCHVOLUME (*continued*)

MEDIATYPE (*continued*)  
 MEDIA7 146, 242, 319, 395  
 MEDIA8 146, 242, 319, 395  
 MEDIA9 146, 242, 319

### RECORDINGFORMAT

EEFMT2 146, 242  
 EEFMT3 146  
 EEFMT4 63  
 EFMT1 146, 242, 319, 395  
 EFMT2 146, 242, 319  
 EFMT3 146  
 EFMT4 63

### segmentation

for 3592 264  
 for TS1120 179  
 for TS1130 95  
 for TS1140 9

### sending comments to IBM xxi

shortcut keys 417  
 SMS 37, 117, 207, 299, 377  
 EFMT1 213, 302, 380  
 EFMT2 41, 121, 213, 302  
 ISMF 41, 121, 213, 302, 380  
 recording technology 41, 121, 213, 302, 380  
 SMS configuration services 41, 121, 213, 302, 380

### SMS-managed TCDB volume records 385

### SMS-managed TVR volume records 385

### stand-alone library

coexistence considerations 348  
 for 3592 Model E05 272  
 for encryption-capable TS1120 tape drive 188  
 for TS1130 tape drive 16, 100

customization 353  
 for 3592 Model E05 276  
 for encryption-capable TS1120 tape drive 195  
 for TS1130 tape drives 106  
 for TS1140 tape drives 22

### implementation 357

for 3592 Model E05 280  
 for encryption-capable TS1120 tape drive 199  
 for TS1130 tape drives 26, 109

planning for 351  
 for 3592 Model E05 274  
 for encryption-capable TS1120 tape drive 192  
 for TS1130 tape drive 19, 103

using 3592 Model E05 tape drives 268  
 using 3592 Model J tape drives 344  
 using encryption-capable TS1120 tape drives 183  
 using TS1130 tape drives 97  
 using TS1140 tape drives 12

### Summary of changes xxiii

syntax conventions  
 how to read xvii

syntax diagrams  
 how to read xvi

system error summary report  
 3490 324, 402

system error summary report (*continued*)  
3590 324, 402  
3592 Model E05 324

## T

tape devices  
3490 42, 122, 214, 303, 380  
3590-1 42, 122, 214, 303, 380  
automated tape library  
environment 42, 122, 214, 303, 380

tape drive  
3592 Model E05 261  
3592 Model J 339  
TS1120 261  
TS1120 encryption-capable 169  
TS1130 89  
TS1140 3

tape encryption 3, 89, 170  
Tape Hardware Emulation 56, 136, 230  
TAPE Media Informational Messages  
(MIMs)  
3592 74, 154

tape subsystem exception report  
3590 323, 401  
3592 153  
native device type 73, 153, 323, 401  
TS1140 73

Tape Volume Record (TVR)  
TS1140 support  
OCE processing 47

TAPEUTILIZATION 59, 138  
TAPEUTILIZATION and PERCENTFULL  
determining capacity 58, 138, 232,  
312, 389

Tivoli Key Lifecycle Manager (TKLM) 6,  
92

TKLM (Tivoli Key Lifecycle Manager) 6,  
92

Total block count SFI 68

TS1120 tape drive 261  
encryption-capable 169  
media support for 176  
introduction for 261

TS1130 tape drive 89  
DFSMSdss 131  
DFSMSdss considerations 131  
DFSMSShsm considerations 133  
introduction to 89  
media support for 92

TS1140  
OCE processing  
WORM support 47

TS1140 tape drive 3  
DFSMSdss considerations 51  
DFSMSShsm considerations 53  
introduction for 3  
media support for 7

TVR (Tape Volume Record)  
TS1140 support  
OCE processing 47

## U

USE6 67, 150  
USE6 ('8AE030') - Volume Usage  
Factor 151  
USEM 67, 150  
USEM ('8AE000') - Volume Usage  
(KB) 151  
user interface  
ISPF 417  
TSO/E 417

## V

VLPOOL MASTEROVERWRITE operand  
in parmlib 397  
Volume Usage Factor SFI 151  
Volume Usage SFI 151

## W

WORM  
TS1140 support  
OCE processing 47

WORM tape cartridge  
aggregate backup and recovery 313,  
390  
rejection at OPEN 313, 390

## Z

z/OS DFSMS 37, 117, 207, 299, 377





Product Number: 5650-ZOS

Printed in USA

SC23-6854-00

