



*Smart*Cities

From Smart Grids to Smart Energy Services



José Arrojo
Corporate Director of Technology and Innovation

Berlín, Jun 24th 2009

Energy

Brussels 2006, 19th October
20% energy saving until 2020: the European Commission exposes the Energetic Efficient Action Plan



smartcity

**Smart
Grids**



**Smart
Energy Generation
and Storage**



**Smart
Mobility**



**Smart
Buildings**



Fuente: H2PIA



**Smart
and Informed
Customer**



Supported by technology we can achieve the transition to a low carbon society (-50%)

SmartCity of Málaga: a World Reference

This project will become a world reference together with other on-going initiatives

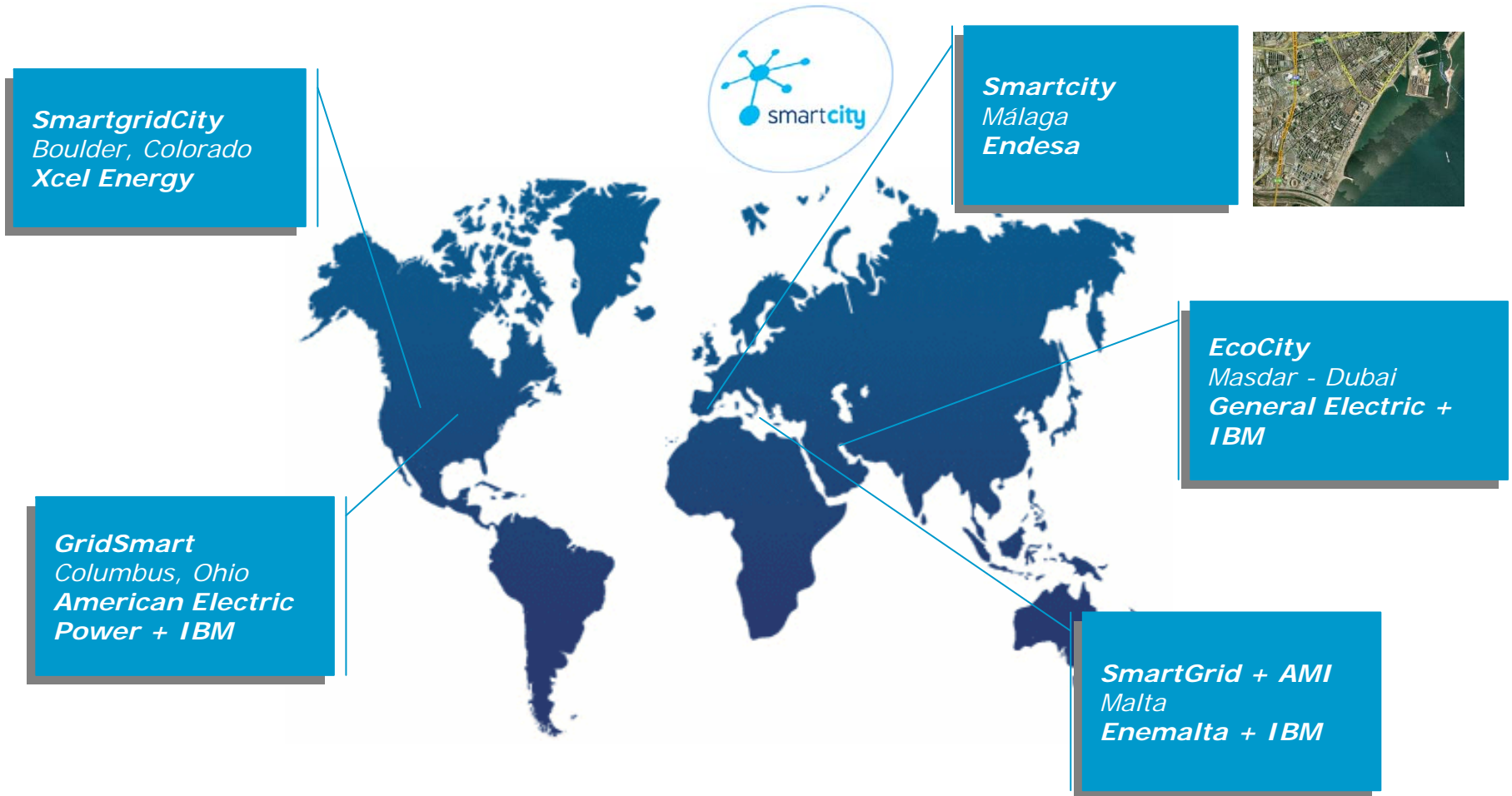

High technology solutions will be integrated at large scale and deployed involving the distribution network and the final customer

Smart and Informed Customers

Citizens must be involved and committed

“Carbon footprint” measurement

Energy efficiency and demand management programs

Information and energy awareness programs

Smart Energy Management

Efficient management of energy end-use

Internet-based energy management systems

Homes and SMEs demand response programs

Efficient public lighting and citizen services

Smart Generation and Storage

Renewable energy self-generation and storage

Solar photovoltaic panels and micro-wind power

Energy storage

Electric vehicles

SmartGrids

Smart distribution networks

Medium and low voltage operation and automation

Efficient integration of distributed generation

AMI (electricity, water and gas)

Information and Telecommunication Systems for real time operations

Location: Málaga



Location: Seafront, area recently built-up. 3 Km² surface

Customers	12.000
Substation	San Sebastián
MV Lines	5
Power placed	35 MVA
Transformation centres	65

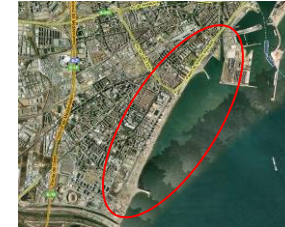

Area details

- LV generation. LV Photovoltaic installations placed in public buildings as schools. Monte Malaga Hotel, sustainable designed. Photovoltaic and thermal panels.
- MV Network automation. New transformation centres with automation capacity, monitoring and communications.
- Relevant customers. Active demand management.
- Outside parking situated across the seafront, the sports centre, the athletics stadium and in the old thermal central area.
- Residential buildings. Expanding area in Malaga, several houses are being built.
- MV generation. Pending the tri-generation connection (2.74 MW)
- Possibility of including other initiatives in the area: Smart House Project





- 31 million EUR budget with companies and research centers
- 4 years demonstration project with field technology and involving the final customer
- Deployment plan, construction and services operating, analysis of results and knowledge diffusion activities
- “Living lab” for test and trials of new technologies and services
- “Projects call for new projects”, new projects are expected to arise as new opportunities are identified

SmartGrids need an strong technology effort

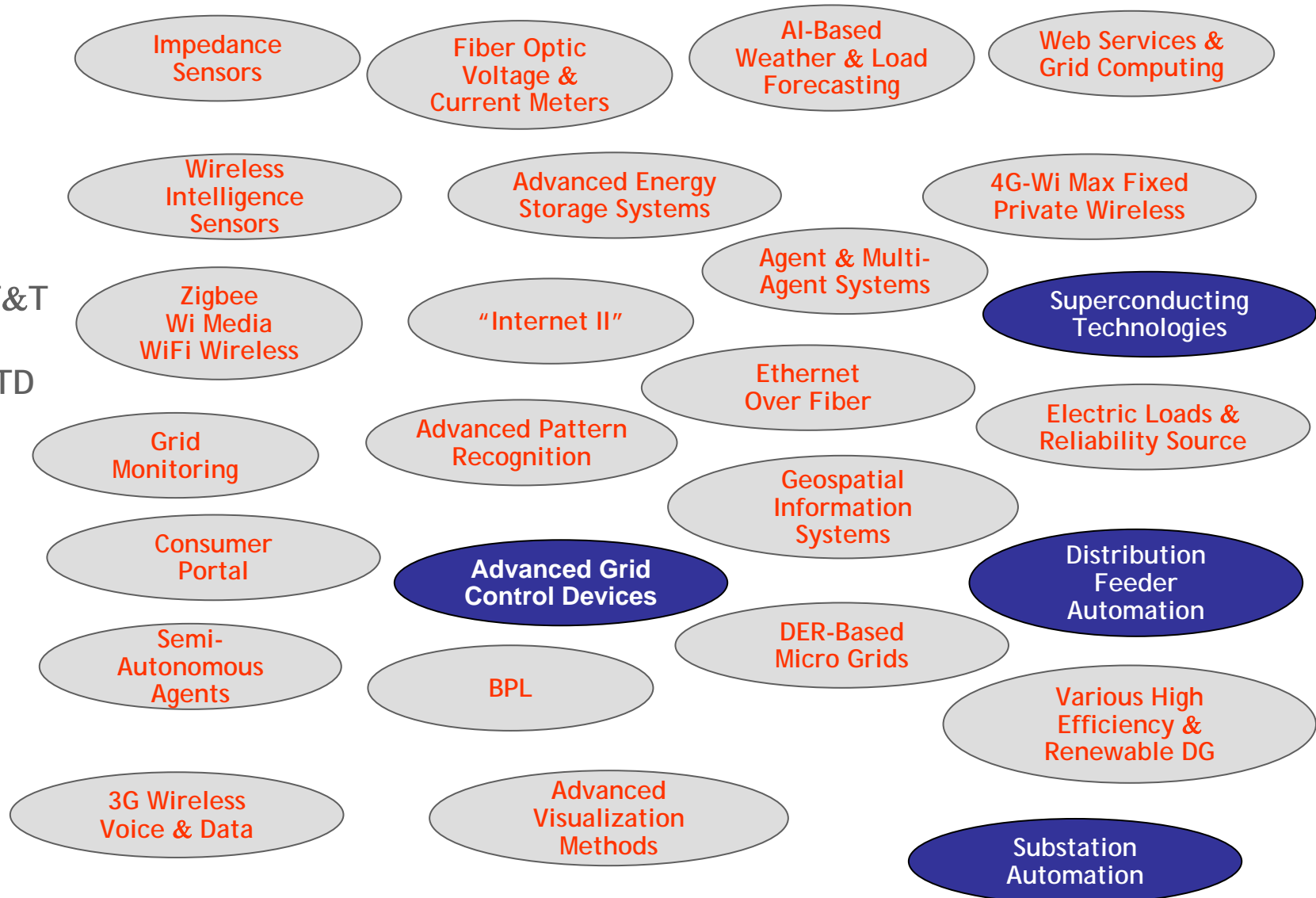

Electric Vehicles

- 10% cuota in the next 10 years
- Several technologies and applications involved

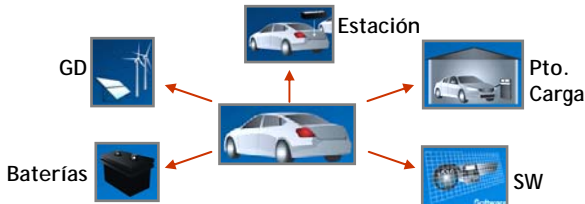

Distributed Generation

- MicroGrids will irrupt

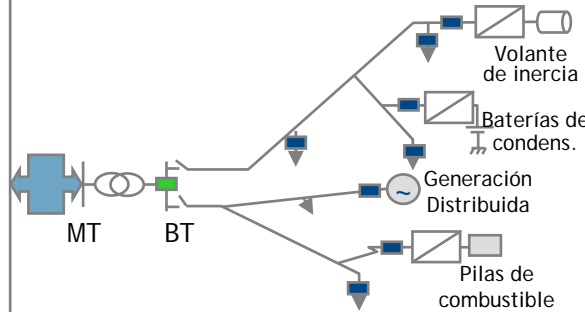

Real Time Monitoring

- It enables reduction of O&M expenses and increases quality of service

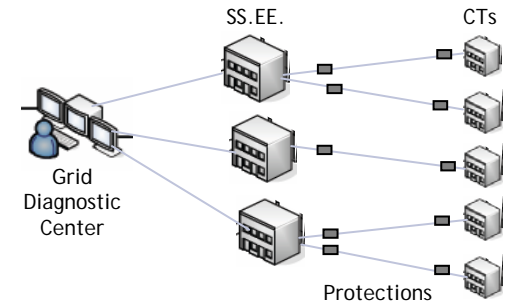

Domotics and in-home devices

- It will transform the Customer Relationship

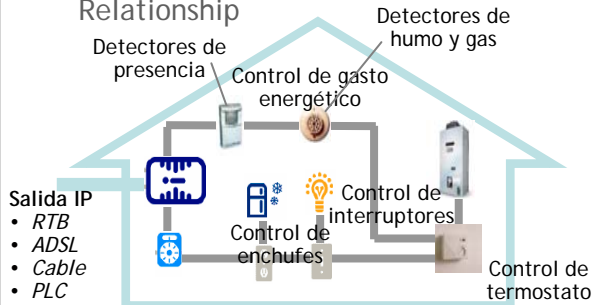

Demand Side Management

- Peak reduction and load shift

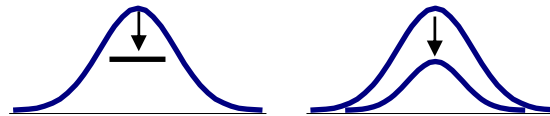

Energy Storage at all levels

- Fuel Cells, Batteries, Inertial wheels, etc will be available at all levels

